

DIGITAL MULTIMETER 5017

7 ½ Digit Precision Multimeter with IEEE-488 and RS232 Interface

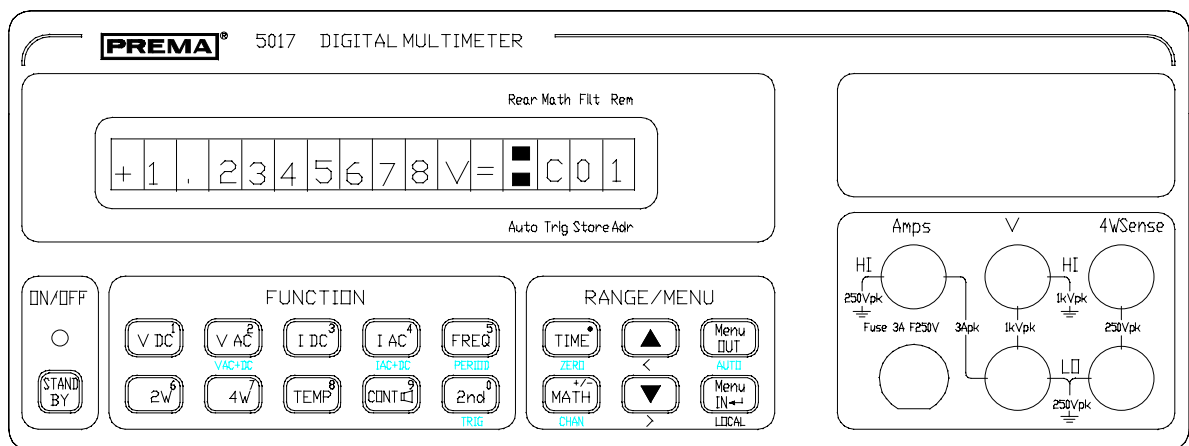

DMM 5017 / DMM 5017 SC

User's Manual

Table of Contents

TABLE OF CONTENTS	1
1 INTRODUCTION	1-1
1.1 Features	1-1
1.2 Various Versions	1-1
1.3 Important Safety Instructions	1-2
Reading the User Manual	1-2
Further Safety Instructions	1-2
Predictability of Dangers	1-3
Proprietary Rights	1-3
Conformity Declaration	1-3
Proper Utilization as intended	1-3
Availability of the User Manual	1-5
2 GETTING STARTED	2-1
2.1 Delivery	2-1
2.2 Safety Guidelines	2-2
Utilization	2-2
2.3 Safety Symbols	2-3
2.4 Accident Prevention	2-3
2.5 Connecting the Unit to Main Power	2-3
2.6 Grounding	2-4
2.7 Warranty	2-5
2.8 Certificate	2-5
2.9 Turning it on	2-5
2.10 Connection of Measurement Leads	2-6
Operation with rear panel inputs and Scanner	2-8
2.11 Rack Mounting	2-8
2.12 Miscellaneous	2-9
Conforming to the Norm EN 61010	2-9
Scanner with Model 5017SC	2-9
3 QUICK START	3-1
3.1 Default Settings	3-1
3.2 Scanner (5017SC)	3-1
3.3 Measuring Voltage	3-2
3.4 Measuring Current	3-3

3.5 Measuring Resistance	3-4
3.6 Measuring Temperature	3-5
3.7 Frequency and Period Measurement	3-6
3.8 Continuity Test	3-7
3.9 Selecting Measurement Ranges	3-7
3.10 Setting the Integration Time / Resolution	3-8
3.11 Display	3-9
Display with Settings	3-9
Meaning of the Settings	3-9
Display with Mathematics	3-10
Display with Channel	3-10
Display with Time Counter	3-11
4 MANUAL OPERATION	4-1
4.1 Keypad	4-1
The Function Field	4-2
The Range / Menu Field	4-3
4.2 The Display Field	4-4
Display Elements	4-4
4.3 Measuring Inputs	4-5
Connecting the Measuring Cables	4-5
Limiting Data for the Measuring Inputs	4-6
4.4 Setting the Measuring Functions	4-7
4.5 Measuring Range Selection	4-7
4.6 Channel Selection for 5017SC	4-8
4.7 Offset Correction	4-8
4.8 Navigating in the Menu Structure	4-9
4.9 Mathematical Programs	4-11
Selection / Manual Control	4-11
Meaning of the Mathematical Programs	4-12
4.10 The Menu "Configure"	4-13
Start Mode / Trigger Mode	4-13
Filter	4-13
Automatic Filter (Auto Filter)	4-14
Fast Automatic Filter (Fast Auto Filter)	4-14
Moving Average Filter (Avg. Filter)	4-14
Filter Selection	4-15
Saving and Loading Instrument Settings	4-15
Power-Up Status	4-16
Calibration	4-16
4.11 The Menu "Device"	4-17
Setting the Contrast	4-17
Preselecting the Interface	4-18

Preselecting the Command Set for Remote Control	4-19
Selecting the Temperature Sensor	4-20
Activating the Loudspeaker	4-21
Setting the Display Formats	4-21
Setting the Scanner Mode	4-23
4.12 Error Messages	4-24
5 REMOTE CONTROL	5-1
5.1 Configuration	5-1
Select Interface	5-1
Configuring the RS232 Interface	5-1
Configuring the IEEE-488 Interface	5-2
Define the Command Set	5-2
5.2 General Information concerning Remote Control	5-3
5.3 Special Features for the RS232 Interface	5-3
5.4 Capabilities of the IEEE-488 Bus Interface	5-4
General IEEE-488.1 Messages	5-4
5.5 RS232 / IEEE-488.2 Common Commands	5-5
*CLS, Clear Status Command	5-5
*ESE Standard Event Status Enable Command	5-6
*ESE? Standard Event Status Enable Query	5-6
*ESR? Standard Event Status Register Query	5-6
*IDN? Identification Query	5-7
*OPC Operation Completed Command	5-7
*OPC? Operation Completed Query	5-7
*RST Reset Command	5-7
*SRE Service Request Enable Command	5-8
*SRE? Service Request Enable Query	5-8
*STB? Read Status Byte Query	5-8
*TST? Self Test Query	5-9
*WAI Wait-to-Continue Command	5-9
5.6 Structure of the Registers	5-10
5.7 Operation as Listener	5-11
5.8 Display Mode	5-14
5.9 String Length Selection	5-16
5.10 SRQ Mode	5-16
5.11 Operation of the Digital Multimeter as TALKER	5-16
Description of the Message Record Sent	5-17
Table of Device Messages sent by the Multimeter	5-18
Meaning of the Transmitted Characters	5-19
5.12 Error Messages	5-21
5.13 Compatibility	5-23
5017 as Listener	5-23

5017 as Talker	5-25
Difference between 5017 and 6001 concerning hardware	5-27

6 CALIBRATION **6-1**

6.1 Calibration Periods	6-1
6.2 PREMA Calibration Service	6-1
6.3 Necessary Equipment	6-1
6.4 Automated Calibration	6-2
6.5 Important Steps prior to Calibration	6-3
6.6 PIN Number and Calibration Switch	6-4
Changing the PIN Number	6-5
6.7 Offset Correction	6-6
6.8 Calibrating DC Voltage	6-7
Offset Correction for DC Voltage	6-7
Calibration of DC Voltage	6-7
6.9 Calibration of Resistance Ranges	6-8
Offset Correction	6-8
Calibration of Resistance	6-8
6.10 Calibration of AC Voltage	6-9
6.11 Calibration of DC and AC Current	6-9
6.12 Calibration of Temperature	6-9
6.13 Storing Calibration Values	6-11

7 OPERATING INSTRUCTIONS **7-1**

7.1 DC Voltage Measurement	7-1
Input Resistance in DC Voltage	7-1
Series Mode Suppression	7-2
Common Mode Suppression	7-3
Thermal Voltages	7-3
Noise Effects Through Inductive Interferences	7-4
7.2 Resistance Measurement	7-5
Two-Wire Resistance Measurement	7-5
Four-Wire Resistance Measurement	7-7
Power Dissipation in the Resistors	7-8
7.3 AC Voltage Measurement	7-8
7.4 DC and AC Current	7-9
7.5 Temperature Measurement	7-10

8 CONSTRUCTION **8-1**

8.1 Input Circuit	8-1
8.2 Integrating A to D Converter	8-2
Mains Synchronization	8-3

Reference	8-4
8.3 Measurement of AC Voltage	8-5
Frequency, Period	8-5
RMS to DC Converter	8-5
8.4 Application of Microprocessors	8-6
Main Processor	8-6
Power Management	8-7
Other processors	8-7
8.5 Ports	8-8
Display	8-8
Memory	8-8
Serial Port	8-8
IEEE-488 Port	8-8
Trigger Port	8-8
8.6 Measurement Inputs	8-9
Front / Rear Measurement Connectors	8-9
8.7 Power	8-9
8.8 5017SC	8-10
Scanner	8-10
9 TECHNICAL SPECIFICATIONS	9-1
<hr/>	
9.1 DC Voltage	9-1
9.2 Resistance	9-5
9.3 AC Voltage	9-7
9.4 DC Current	9-9
9.5 AC Current	9-11
9.6 Temperature	9-12
9.7 Frequency and Period	9-14
9.8 Special Functions	9-15
9.9 Scanner with Model 5017SC	9-16
Pin Assignment of the Scanner	9-17
9.10 IEEE-488 Interface	9-19
9.11 RS232 Serial Interface	9-21
9.12 Trigger Interface	9-23
9.13 EU Conformity	9-24
EMC Compliance Tests	9-24
Measurement of the EMI Emissions	9-24
Measurement of EMI Immunity	9-25
9.14 General	9-26
10 ACCESSORIES	10-1
<hr/>	
10.1 Adaptercard (3110)	10-1
10.2 Mating Plug for Sub-D (6000/03)	10-2

10.3 Pt100 Temperature Probes (3011 and 3012)	10-2
10.4 Test Lead Set (3014)	10-2
10.5 Set of Short Circuit Plugs (3016)	10-3
10.6 Current Shunt (3017)	10-3
10.7 RS232 Cable (3018)	10-3
10.8 Carrying Case (4100)	10-3
10.9 Accessories for the IEEE488 Bus	10-3
10.10 19-inch Rack Mounting Kit (5021 G)	10-4
<u>INDEX</u>	<u>R-1</u>

1 Introduction

With the Digital Multimeter 5017 you are now the owner of a 7 ½ digit measuring instrument of the newest generation from PREMA.

This instrument is convincing by virtue of its outstanding measuring capabilities and functional versatility.

1.1 Features

The following features of the 5017 are of special interest:

- Very good stability with only 4 ppm tolerance and annual drift of 20 ppm.
- Additional measuring functions such as frequency and period duration.
- Temperature measurement with various Pt sensors (Pt10, Pt25, Pt100, Pt500 and Pt1000)
- Good system capabilities with the RS232 and the IEEE-488 interface
- Large clearly readable liquid crystal display (LCD)
- Standard case dimensions: Half 19 inch width and 2 height units.
- The 5017SC with built-in scanner for up to 80 measuring points (80x1-pole, 40x2-pole, 20x4-pole)

1.2 Various Versions

In the standard version, the 5017 is fitted with banana safety sockets on the rear in addition to the front panel sockets. A scanner is incorporated in the 5017SC. The scanner connections are located on the rear panel in the form of 50-pole SubD sockets. An adapter card is available (see chapter 'Accessories') for connecting the scanner via screw terminals.

Prior to using the connections on the rear, a plug strip connector must be transferred inside the instrument. The designator "Rear" is then lit in the display.

For the 5017SC current measuring ranges and the 1000V range can be selected only when using the front panel sockets (maximum permissible voltage 125 Vpk at the scanner's rear input).

1.3 Important Safety Instructions

Reading the User Manual

Proper working procedure with this instrument is possible only after reading all instructions, hints and procedure specifications attentively and understanding them.

Please get in touch with PREMA before commencing operation of the instrument if you do not understand something in the user manual or the instructions, procedural descriptions and safety regulations are unclear.

This user manual has been written to make the instrument understandable for operation in the manner intended. It contains important instructions for safe, correct and efficient operation of the instrument.

Dangers are avoided, repair costs and downtime reduced and the service life of the instrument is extended only when these instructions are observed. The user manual should always be available at the place where the instrument is operated.

Incorrect manual control or failure to observe the instructions given here may endanger persons (also third parties) or cause material damage.

Personnel entrusted with operating this instrument must have read this user manual attentively and must be familiar with all safety instructions.

In addition to the instructions given in this user manual, the local regulations for preventing accidents in force at the operating site apply, as well as the relevant rules for safe and proper working procedure.

Further Safety Instructions

Further safety instructions are contained in the chapter headed "Getting Started". Explanations and instructions are given there for the warning signs and symbols on the instrument for recognising specific sources of danger. It is essential to observe and comply with all safety instructions. The warning symbols must be held complete and in good readable condition.

Predictability of Dangers

The manufacturer cannot anticipate every conceivable danger.

If a task is not carried out in the manner recommended, the operator must make sure that this does not entail any danger for himself and other persons.

He should also make sure that the instrument cannot be damaged or endangered by the chosen manner of operation.

This user operating manual is not an instruction manual for making repairs.

The instrument should be returned to the factory for any necessary repairs.

Proprietary Rights

This user manual is protected by proprietary rights. No part thereof may be copied, reproduced or distributed in any form without prior written permission.

Conformity Declaration

PREMA has issued an EC conformity declaration for this instrument. This declaration certifies that the instrument complies with the relevant requirements of the EC directives.

Proper Utilization as intended

These instruments have been built conforming to the recognized technical safety principles, but nevertheless if it is not used and operated in the manner intended, dangers may arise for body and life of the user or third persons, or damage may be incurred by the instrument and other objects.

The instrument may therefore be operated only in technically perfect condition, in the manner intended and with due awareness of safety considerations and dangers, observing the contents of the user manual and the regulations for the prevention of accidents. It should be used exclusively for the tasks described in this user manual.

All faults on the instruments which impair the safety of the user or third persons must be remedied immediately.

PREMA accepts no liability for damage resulting from utilization of this instrument in any manner other than the intended manner described in the user manual. The user alone carries the risk and responsibility for any deviating utilization of the instrument.

Availability of the User Manual

The user manual must always be available at the place where this instrument is operated. The personnel entrusted with operation of this instrument must be familiar with all task procedures described in the user manual and with all safety instructions.

All warning and safety instructions attached to the instrument must be held complete and in clearly readable condition.

No modifications, attachments or conversions of the instruments are permitted without consent and approval by PREMA, otherwise the conformity becomes void.

2 Getting Started

2.1 Delivery

Every PREMA unit is thoroughly and carefully checked before it is shipped, to ensure that it is in flawless condition, and that its technical characteristics are within specifications.

Consequently, upon receipt, the unit should be in perfect condition, mechanically and electrically.

To make sure that the unit has not been damaged during transport, it should be thoroughly checked out immediately after receipt. If damage is detected, a damage claims form should be completed with the shipping carrier.

Please use the following list to assure that delivery is complete:

-  1. Power Cable
- 2. User Manual, English
- 3. Calibration Certificate with Date and Signatures
- 4. Product Registration Card, which you should fill out and mail back to PREMA
- 5. Any optional equipment ordered

Please ensure also, that the unit is set up for the right AC Voltage, with the right type of fuse (see chapter “Connecting the Unit to Main Power”).

Important: Do not throw the box and packaging materials away!
If the unit has to be sent back to the factory for recalibration or repair, only the original packaging materials will provide sufficient protection against damage.

2.2 Safety Guidelines

Also refer to the safety guidelines in the “Introduction” chapter, please.

The multimeter may only be operated if it is in perfect and safe condition. Accident prevention and environmental protection rules must also be followed.

All power-up and power-down procedures described next must be followed. Problems, such as loose connections, damaged or scorched cables, oxidized contacts, and damaged fuses must be immediately removed by a professional.

A safe and ecologically sound disposal of operating and support materials, as well as replacement parts, must be arranged. Only genuine replacement parts shall be used. Otherwise, the manufacturer’s warranty and the multimeter’s conformity will be voided.

Any changes to the multimeter, which cause any functional changes, may only be carried out by the manufacturer, or after discussion with and permission by the manufacturer.

Note: Switching operation to the rear panel connectors (or to the scanner) may only be carried out by a professional (see “Connection of Measurement Leads”).

Utilization

The multimeter may only be utilized for the measurement functions that are described in the Technical Specifications. It is especially important to adhere to the load limits of the input connectors. PREMA accepts no responsibility for any damage arising from improper operation.

2.3 Safety Symbols

The signs and symbols on the multimeter, which provide guidelines for safety and handling, are displayed and described below.



This symbol advises the user of a possible danger area. Please consult the manual (see “Connection of Measurement Leads” and Chapter “Operating Instructions”).



This symbol makes the user aware, that a dangerous voltage can be present at measurement connectors.



The CE mark means, that the manufacturer has issued an EC Declaration of Conformity for this multimeter. This declaration certifies, that this multimeter conforms to the pertinent requirements of EC directives.

2.4 Accident Prevention

While using this measurement unit, precautions to prevent an accident should be taken, appropriate to the use of a measurement device.

It is especially important to observe , that during **current measurement**, a very low impedance i.e. 0.1Ω exists between the Hi and Lo connectors, so that a current/voltage, which is applied to the Hi connector, can be contacted by a cable that is connected to the Lo connector.

2.5 Connecting the Unit to Main Power

This PREMA measurement unit is designed to be connected to AC Main Voltage, at a frequency of 50 Hz or 60 Hz. The rear panel of the unit is equipped with a standard DIN grounded power connector.

Before connecting the unit to power, you should make sure that it is set to the right voltage (indicator and fuse).

The voltage selection switch with integrated fuse is located right under the power connector, where you can also read off the current voltage setting; a setting of "220V" represents an AC voltage from 220V to 240V, "110V" represents a voltage from 100V to 120V.

Switching the AC Voltage is done as follows:

- 1. Unplug the unit.
- 2. The clamp for the fuse is located between the plug and the power selector and must be removed. For a setting of "110V" you will need a fuse rated at 0.4A; for "220V" you'll need a fuse rated at 0.2A.
- 3. Place the necessary fuse in the clamp and push the clamp back in.
- 4. Turn the cylinder with the voltage indicators once left or once right to the desired setting, so that the voltage that is currently set is indicated by the white arrow on top.

The indicators are used as follows:

Setting	Voltage Range
110 V	90 V_{RMS} to 130 V_{RMS}
220 V	180 V_{RMS} to 265 V_{RMS}

Table: Main Voltage Ranges

2.6 Grounding

In order to protect the user, the unit's case is grounded through the grounding lead of the power cable. To ensure proper grounding, the power cable should always be connected to a properly grounded power connector.

The unit case is galvanically separated from the measurement connectors and interface ports.

The back of the unit is equipped with a grounded screw, identified by the  symbol, where the user can connect a separate ground line (rack mounting bracket).

2.7 Warranty

PREMA warrants the reliable function of the unit for a period of two years from the date of delivery.

Repairs that need to be carried out during the warranty period are not billed to you.

Damage caused by inappropriate use of the unit, or by surpassing specified limits, does not fall under PREMA's warranty obligations.

Please be aware, also, that PREMA will not be held liable for damages, incidental or coincidental, associated with the use of this measurement device.

2.8 Certificate

Each Digital Multimeter 5017 is provided with a calibration certificate at the factory, certifying the location, date, and traceability of the unit's calibration to the user.

Please look for this certificate at delivery time. It can also be useful as a control for yearly recalibrations, since PREMA warrants that the unit will remain within specifications for one year, and recommends recalibration after that time.

2.9 Turning it on

The multimeter can be switched on with the STANDBY KEY after connecting the power cable. A device setting with measurement function, range and time can be stored as a power-on setting in the "Configure Menu, Settings, Save Settings".

Switch off the instrument also with the STANDBY KEY.

The 5017 is then in standby mode. The red LED at the bottom left of the front panel lights up.

The analog board of the unit is provided with power, even in standby mode, so that no warm-up time needs to be taken into account when the unit is turned on.

Otherwise, warm-up times, as provided in Chapter "Technical Specifications", should be heeded.

Note: The transformer is not disconnected from Mains Power in standby mode.

The instrument starts automatically with power-on after switching-off the unit by pulling the power cord.

2.10 Connection of Measurement Leads

The measurement inputs are implemented as safety connectors. PREMA strongly recommends the use of safety banana plugs with contact protection (see Appendix A, “Accessories, Safety Lead Set”).

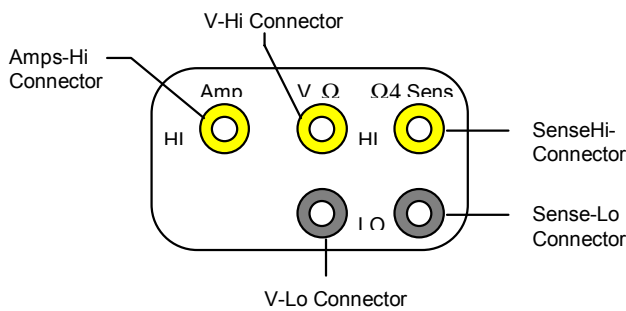

Figure: Measurement Connectors

If the 5017 is not equipped with the Scanner option, safety input connectors are also installed on the rear panel of the unit.

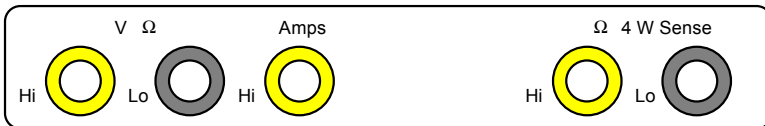

Figure: Rear Panel Input Connectors

Connection of measurement leads should be carried out according to the table on the next page.

In order to switch to the rear panel input connectors, please read the upcoming section, “Operations with rear panel inputs and Scanner.”

The following table gives information about the connection of measurement cables:

Measurement	Hi Connector	Lo Connector
DC and AC Voltage	V-Hi Connector	V-Lo Connector
DC and AC Current	Amps-Hi Connector	V-Lo Connector
2-wire Resistance	V-Hi Connector	V-Lo Connector
4-wire Resistance Source Sense	V- Hi Connector Sense-Hi Conn.	V- Lo Connector Sense-Lo Conn.
Temperature with RTDs Source Sense	V- Hi Connector Sense-Hi Conn.	V- Lo Connector Sense-Lo Conn.
Frequency / Period Voltage Current	V-Hi Connector Amps-Hi Conn.	V-Lo Connector V-Lo Connector
Continuity Test	V-Hi Connector	V-Lo Connector

Table: Connection of Measurement Cables

In dealing with the Scanner option, please refer to chapter "Technical Specifications" for information on measurement cable connections. There you will find a full description of the 50-line Sub-D connectors on the rear panel of the unit.

Operation with rear panel inputs and Scanner

If the 5017 is to be operated from the rear panel inputs or the built-in scanner, please proceed as follows:

- ☞ 1. Please remove all measurement cables from the connectors and unplug the unit.
2. Turn the unit upside down, so that it is lying on its top shell.
3. Remove the four screws from the unit case's bottom shell.
4. Remove the unit case's bottom shell.
5. Tightly grasp and remove and then swap the two front-rear cable-set connectors that are visible on the left, as seen from the front panel of the unit. Only the rear cable-set connector is connected to the preamplifier input circuitry. The front cable-set connector is essentially a place-holder for the input that is not being used.
6. While re-sealing the case, make sure that no wires are caught anywhere.

After turning the unit on (of course, you should first re-seal the unit's cover) the channel indicator field in the display will show the indication "REAR," or a channel number (if the Scanner is installed).

The software automatically checks for any rear-panel connections when the unit is turned on and tests if the cable set connector has been moved from front panel input to rear-panel input.

2.11 Rack Mounting

A rack adapter with two height units is offered for the 5017. The unit has a width of one-half 19-inch, so it can be combined with another half-19-inch unit. More information about rack mounting can be found in the Chapter "Accessories."

When installing the unit into a 19-inch rack, you should take into account, that the ventilation openings in the back are not covered up. In addition, it should be possible to cut power to the unit in an emergency, through the use of an EMERGENCY OFF switch somewhere nearby.

Note: When the unit is installed in a 19-inch rack, and is to be operated through the rear panel inputs or the Scanner, please make sure that the front-rear cable-set connector in the unit has been connected to rear-panel input, prior to installing the unit into the rack (see the previous section on "Connection of Measurement Leads").

2.12 Miscellaneous

Conforming to the Norm EN 61010

The Digital Multimeter 5017 is produced according to EN 61010. This means the highest possible level of safety for the user, in relation to “dangerous body currents,” “high temperatures,” and “mechanical endangerment”.

This has the consequence, that this unit cannot be switched from front-panel to rear-panel input with a switch, as is found with multimeters of other brands.

The minimum of 5.5mm clearance and creepage distance at a nominal voltage of 1000Vdc is not implemented by standard slide switches. When 1000V are applied to the front input connectors, and a switch to the rear input connectors is effected by slider switch, a dangerous transfer of high voltage from the front inputs to the rear inputs can occur.

In our opinion, the manual re-positioning of the Front-Rear cable-set connector is not the most elegant, but certainly the safest solution at the moment. This does not mean, however, that PREMA will not come up with a completely new solution in the future.

Scanner with Model 5017SC

For the model 5017SC with integrated scanner it is important to take the DC and AC voltage limits of the Scanner into account, depending on which option is installed. The input voltage at the rear panel is limited to 125 Vpk with the standard scanner option.

The limit of 1000Vpk continues to be valid for the front input connectors only.

Current measurement and the 1000V range can only be selected while using the front input connectors .

3 Quick Start

3.1 Default Settings

When the unit is turned on for the first time, the following settings are defaulted to:

- Measurement Function Vdc
- Measurement Range 300V
- Measurement Time 1s
- Front Input Connectors Active
- Automatic Filter On (AVG 10)
- Pt100 sensor for temperature measurement
- all other functions switched off

The power-on setting can be stored in the menu "Configure, Settings, Save" .
You can set the instrument to the factory settings with the menu "Configure, Settings, Load Fact, Set".

3.2 Scanner (5017SC)

You can find the inputs of the scanner on the rear panel of the instrument. When delivered the front input connectors are active.

The connections to the scanner can be done with two 50-pole sub-D connectors or two adaptercards 3110 (see chapters "Accessories" and "Technical Specifications").

3.3 Measuring Voltage

Measurement Functions

DC Voltage	VDC key
AC Voltage	VAC key
AC Voltage with DC Component	VAC key and COUPL key

Measurement Ranges

Vdc	300mV, 3V, 30V, 300V, 1000V
Vac	200mV, 2V, 20V, 200V, 700V

Resolution and Measurement Times

Vdc	20 / 40 / 100 ms	5½ digits
	200 / 400 ms / 1s	6½ digits
	2 / 4 / 10 / 20 / 40 / 100 s	7½ digits
Vac	100 ms	5½ digits
	0.2 / 0.4 / 1 / 2 / 4 / 10 / 20 / 40 / 100s	6½ digits

max. Resolution in the smallest range

Vdc: 10nV Vac: 100nV

Frequency Range

Vac: 20 Hz to 1 MHz

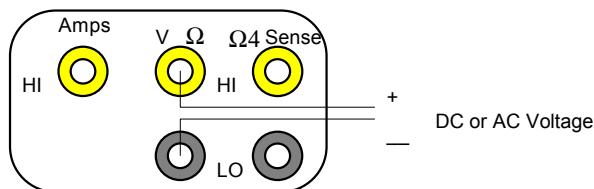

Figure: Connection of measurement leads in Voltage Measurement

The **rear plugs** are connected correspondingly.

For model 5017SC with scanner the measurement leads are connected to Hi and Lo of the respective channel.

3.4 Measuring Current

Measurement Functions

DC Current	IDC key
AC Current	IAC key
AC Current with DC Component	IAC key and COUPL key

Measurement Ranges

I _{dc}	200 μ A, 2 mA, 20 mA, 200 mA, 2 A
I _{ac}	200 μ A, 2 mA, 20 mA, 200 mA, 2 A

Resolution and Measurement Times

I _{dc}	20 / 40 / 100 ms	5½ digits
	0.2s to 100s	6½ digits
I _{ac}	100 / 200 ms	5½ digits
	400 ms / 1 / 2 / 4 / 10 / 20 / 40 / 100 s	6½ digits

Frequency Range

I_{ac}: 20 Hz to 5kHz

max. Resolution in the smallest range I_{dc}: 100pA I_{ac}: 100pA

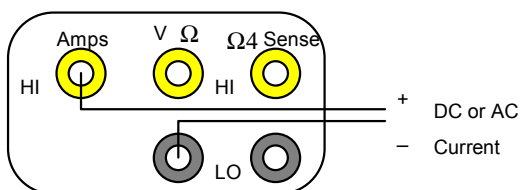

Figure: Connection of measurement leads in Current Measurement

The rear plugs are connected correspondingly.

For model 5017SC with scanner current measurement is possible only through the front plugs.

3.5 Measuring Resistance

Measurement Functions

2-Wire Resistance Measurement Ω 2w key
 4-Wire Resistance Measurement Ω 4w key

Measurement Ranges

300 Ω , 3 k Ω , 30 k Ω , 300 k Ω , 3 M Ω , 30 M Ω

Measurement Times

20 / 40 / 100 ms	5½ digits
200 / 400 ms / 1 s	6½ digits
2 / 4 / 10 / 20 / 40 / 100 s	7½ digits

max. Resolution in the smallest range 7½ digits, 10 $\mu\Omega$

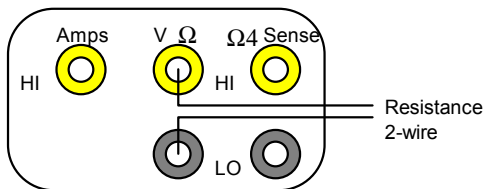

Figure: Connection of leads in resistance measurement (2-wire)

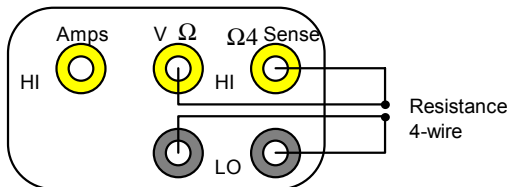

Figure: Connection of leads in resistance measurement (4-wire)

The rear plugs are connected correspondingly.
 For model 5017SC with scanner the measurement leads are connected to Hi and Lo (2-wire) or Hi, Lo (Source) and SHi, SLo (Sense) of the respective channel.

3.6 Measuring Temperature

Sensors

RTDs: Pt10, Pt25, Pt100, Pt500, Pt1000

Sensor Configuration

in the menu "Device, Temp Sensor"

Resolution and Measurement Times

0.01 K / 0.01°C / 0.01°F
0.001 K / 0.001°C / 0.001°F

100 / 200 / 400 ms
1 s to 100 s

Select °C / °F / K

press TEMP key again

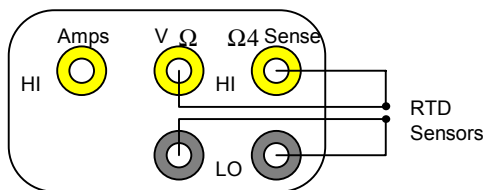

Figure: Connection of measurement leads for RTD Sensors

The rear plugs are connected correspondingly.

For model 5017SC with scanner the measurement leads are connected to Hi, Lo (Source) and SHi, SLo (Sense) of the respective channel.

3.7 Frequency and Period Measurement

Measurement Functions

Frequency for Vac	VAC key and FREQ key
Period for Vac	VAC key and PERIOD key
Frequency for Iac	IAC key and FREQ key
Period for Iac	IAC key and PERIOD key

Select first the function Vac or Iac and adapt the right measurement range. Then select the frequency function.

Time Base 10ms / 100ms / 1s / 10s

Resolution

Frequency	1 Hz, max. 7½ digits, max. frequency 1MHz
Period	Vac: 40µs to 5s / Iac: 100µs to 5s

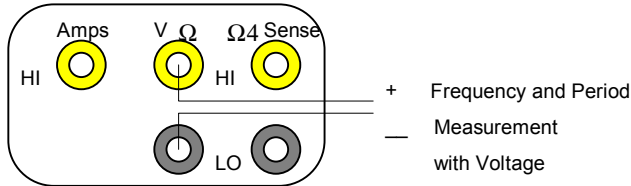

Figure: Connection of Leads in Freq. Meas. of a Voltage

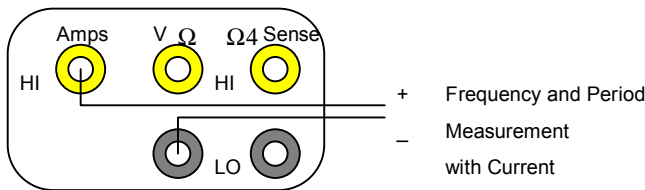

Figure: Connection of Meas. Leads in Freq. Meas. of a Current

The rear plugs are connected correspondingly.
 For model 5017SC with scanner the measurement leads are connected to Hi and Lo (Voltage) of the respective channel.
 Frequency measurement of a current is only possible through the front plugs.

3.10 Setting the Integration Time / Resolution

The integration time (and consequently the resolution) can be changed with the TIME KEY and the cursor keys. The \uparrow KEY increases the integration time, the \downarrow KEY decreases the integration time.

Integration Time	Resolution
20ms, 40ms, 100ms	5½ Digits
200ms, 400ms, 1s	6½ Digits
2s to 100s	7½ Digits *)

*) for Vdc and Ω

Table: Integration Times and Resolutions

Note: Range and Integration Time are stored for the respective measurement function.

3.11 Display

The display can be changed and configured in the menu "Device, Display", format.

Display with Settings

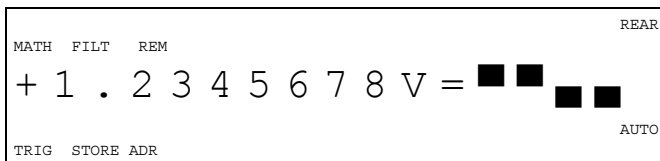

Figure: Display with Settings

Selecting with Menu "Device, Display, Settings".

Meaning of the Settings

Settings	Bedeutung
REAR	Rear inputs are active
MATH	Mathematic program is active
FILT	Filter is switched on
REM	Device is in remote mode
AUTO	Auto Ranging is switched on
TRIG	Device is in trigger mode
STORE	not used
ADR	Device is in talker / listener mode

Table: Meaning of the Settings

Display with Mathematics

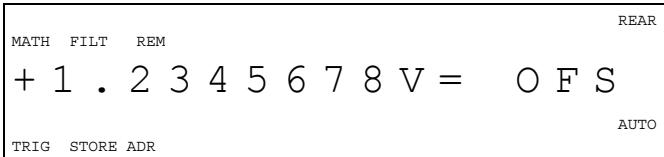

Figure: Display with Mathematics

Selection with "Menu Device, Display, Math".

Abbreviation	Meaning
OFS	Offset $x - a$
LIN	Linearization $ax + b$
RTO	Ratio x / a
DEV	% Deviation $100 * (x - a) / a$
dB	dB
dBm	dBm

Table: Meaning of the Mathematics Abbreviations

Display with Channel

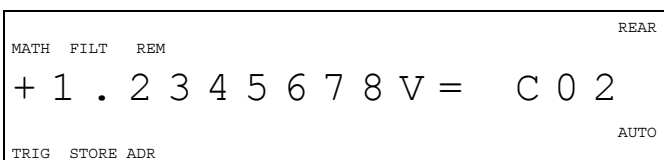

Figure: Display with Channels

Selection with Menu "Device, Display, Channel".

The last two digits in the display show the channel number.

Display with Time Counter

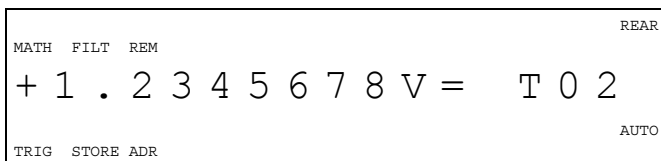

Figure: Display with Time Counter

Selection with "Menu Device, Display, Sec Counter".

The last two digits are counting the seconds for measurement times of more than 2s.

4 Manual Operation

4.1 Keypad

The user friendly design of the front panel permits quick and effective working with this instrument. On the one hand the keyboard provides direct access to important functions of the instrument such as measuring function and range setting, preselection of the measuring time and activation of a mathematical program. On the other hand, more complex settings can easily be made with the cursor and menu control.

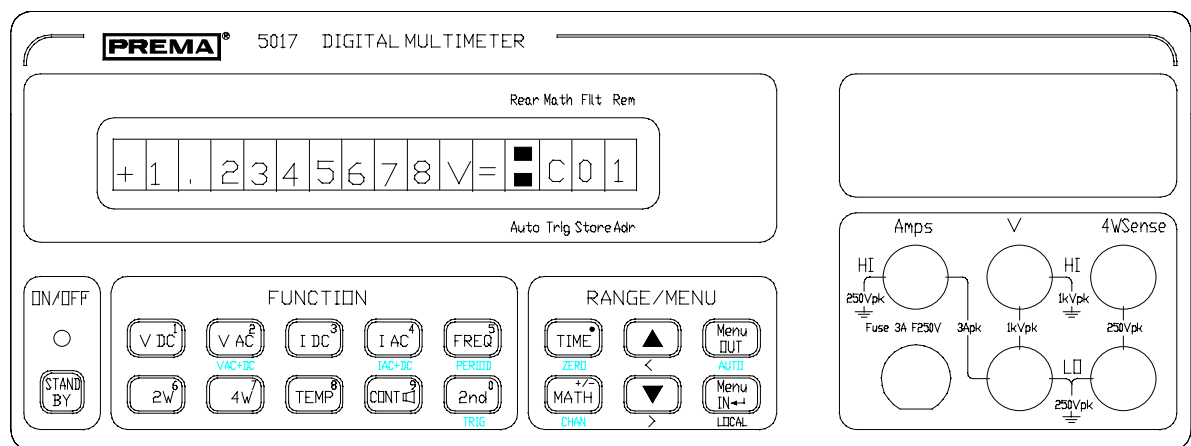

Front view of the 5017

Blue legend is present under some of the keys. The functions corresponding to this legend are activated after first pressing the 2nd key (second function key).

Apart from the normal function assignment, some keys have a numerical second assignment. This second assignment is activated when it is necessary to make numerical entries, for example in the mathematical programs or for calibration.

The Function Field

KEY	Key function
ON/OFF (Standby)	Switches the processor section of the instrument on and off. In standby mode the analog electronic circuits are still powered up, i.e. the instrument is ready sooner for operation with full accuracy after switch-on.
VDC	Direct voltage measurement (numerical: 1)
VAC	Alternating voltage measurement as true RMS without DV component (numerical: 2).
VAC+DC (2nd + VAC)	Alternating voltage measurement as true RMS with DV component.
IDC	Direct current measurement (numerical: 3).
IAC	Alternating current measurement as true RMS without DC component. (numerical: 4).
IAC+DC (2nd + IAC)	Alternating current measurement as true RMS with DC component.
FREQ	Frequency measurement for Vac and Iac (numerical: 5).
PERIOD (2nd + FREQ)	Period duration measurement for Vac and Iac.
Ω 2W	2-wire resistance measurement (numerical: 6).
Ω 4W	4-wire resistance measurement (numerical: 7).
TEMP	Temperature measurement with a preselected sensor, repeated pressing of this key cycles through °C, °F and Kelvin (numerical: 8).
CONT	Continuity testing
2nd	Switches over for the blue legend under the keys.
TRIG (2 x 2nd)	Executes a manual trigger.

Table: The keys in the function field

The Range / Menu Field

KEY	Key function
TIME	The measuring time and thus the resolution can be changed in conjunction with the cursor keys (numerical: Dot).
ZERO (2nd + TIME)	Starts an offset correction (zero point adjustment).
MATH	Activates and deactivates calculation mode of the instrument with the preset mathematical program (numerical: "+/-").
CHAN (2nd + MATH)	Selects a measuring channel. Implemented only in instruments with built-in measuring point scanner.
↑	Switches to the next higher measuring range. Automatic range switching is deactivated. The cursor keys control the entry within the operating menus.
↓	Switches to the next lower measuring range. Automatic range switching is deactivated. The cursor keys control the entry within the operating menus.
Menu OUT	Switches back one menu level.
AUTO (2nd + Menu OUT)	Activates automatic range switching (autoranging).
Menu IN ↵	Activates menu control, press Enter to confirm, or switches one menu level deeper.
LOCAL (Menu IN ↵)	When in remote control mode, pressing this key switches the instrument to local mode.

Table: The keys in the Range / Menu field

4.2 The Display Field

The alphanumeric liquid crystal display (LCD) shows the measurement reading, the measuring unit and a status display (or the currently active channel or the set measuring time).

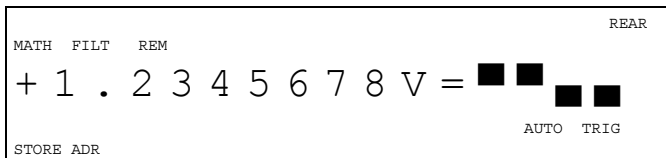

Display Elements

1 to 10 Used to display the 5½- to 7½ digit measurement reading or calculation result with sign, or error messages.

11 to 12 Used to display the selected measuring function.

Display	Measuring function
V / mV	Direct voltage
V~ / mV~	Alternating voltage
V=~ / mV=~	Alternating voltage with direct voltage component
A / mA	Direct current
A~ / mA	Alternating current
A=~ / mA	Alternating current with direct current component
Hz	Frequency
s	Period duration
°C, K, °F	Temperature

13 REAR for input sockets activated on the rear panel
 AUTO for autoranging ON

14 MATH for mathematical functions ON
 TRIG for trigger mode ON

15 FILT for filter ON

STORE not used

16 REM for remote control ON
ADR for device mode as Talker or Listener

or

14 to 16 Channel number display when "Channel" has been chosen in menu "Device, Display". Is active only when the measuring points scanner is activated.

or

14 to 16 Mathematical display when "Math" has been chosen in menu "Device, Display". Is active only when mathematical functions are . selected.

or

14 to 16 Seconds counter when "Sec-Counter" has been chosen in menu "Device, Display". The seconds counter is active only when the measuring time is 4 seconds or longer.

Further information on the display is contained in the chapter headed "Quick Start".

4.3 Measuring Inputs

For connecting the measuring signals, the 5017 is equipped on the front panel and optionally on the rear panel with low thermoelectric EMF safety sockets for banana plugs.

With the 5017SC with built-in measuring points scanner, switchover to the scanner inputs is possible internally in the instrument.

Read chapter 'Getting Started' headed "Connection of Measurement Leads" for the instructions for switching over to the inputs on the rear of the instrument.

Connecting the Measuring Cables

The signal which is to be measured should always be connected in such a way that the lead closest to ground potential is connected to the black input socket (LO) and the line with the higher potential is connected to the red input socket (HI). The display then shows a reading with positive sign.

Please read chapter 'Getting Started', "Connection of Measurement Leads" for connecting the measuring cables for each measuring function.

The pinout of the measuring inputs of the measuring points scanner is specified in the chapter "Technical Specifications".

Limiting Data for the Measuring Inputs

The stipulated limiting data must be observed when connecting signals to be measured. These limiting data are stated in red legend on the front panel adjacent to the corresponding input connectors (Vpk means peak volts).

Measuring Input	Front or Rear Sockets	Measuring Points Scanner
V Ω - Hi-Lo	1000 Vpk	125 Vpk
Lo-Ground	250 Vpk	125 Vpk
Sense Hi-Lo	250 Vpk	125 Vpk
Sense Lo-Ground	250 Vpk	125 Vpk

Table: Limiting data for the measuring inputs

4.4 Setting the Measuring Functions

All measuring functions are selected with a single keystroke. Period duration, Vac+dc and Iac+dc must be activated by first pressing the 2ND KEY. The selected measuring function appears in the display immediately after pressing the key. The first reading is displayed after elapse of the set integration time plus an internal waiting time.

4.5 Measuring Range Selection

The measuring ranges can be set in fixed manner or they can be selected automatically by the instrument. Automatic selection is made with the AUTO function (2nd + MENU OUT KEY).

The ↓-KEY switches to the next lower range. The ↑-KEY switches to the next higher range. The position of the decimal point indicates the currently selected measuring range.

The following table gives an overview of the measuring ranges which can be set.

Range	Function	Range	Function	Range	Function
300 mV	Voltage	300 Ω	Resistance	200 μA	Current
3 V	Voltage	3 kΩ	Resistance	2 mA	Current
30 V	Voltage	30 kΩ	Resistance	20 mA	Current
300 V	Voltage	300 kΩ	Resistance	200 mA	Current
700 / 1000 V	Voltage	3 MΩ	Resistance	2 A	Current
		30 MΩ	Resistance		

Table: Ranges which can be set

4.6 Channel Selection for 5017SC

The channels of the built-in measuring points scanner can be selected in two ways:

1st possibility

Keypress	Display / Action
CHAN: 2 ND + MATH	1 <u>↑↓</u> Channel : 12
↑-KEY	increases the channel number by one
↓-KEY	decreases the channel number by one
MENU-OUT KEY	terminates the entry and switches on the desired channel

Table: Channel selection with cursor keys

2nd possibility

Keypress	Display / Action
CHAN: 2 nd + MATH	1 <u>↑↓</u> Channel : 12
MENU-IN KEY	1 <u>↑↓</u> Channel : 1 <u>2</u> permits numerical entry for the channel marked by the cursor, using the numerical keys in the function field
↑-KEY	Cursor to left (tens digit)
↓-KEY	Cursor to right (units digit)
MENU-IN KEY	confirms the entry
MENU-OUT KEY	terminates the entry and switches on the desired channel

Table: Channel selection by direct numerical entry

Function, range and integration time are stored for every channel and remain valid after channel switching.

4.7 Offset Correction

An offset value produced by thermoelectric EMFs or by the resistance of the measuring leads can be corrected digitally with the "ZERO" (2nd + TIME) -KEY. Further details for this function are given in chapters "Calibration" and "Operating Instructions".

4.8 Navigating in the Menu Structure

The first menu level is designated by upper case letters. Two dots appear if there are any deeper menu levels.

Manual control of the menus is as follows:

Keypress	Display / Action
MENU-IN KEY	activates menu control
↑-KEY	switches to the previous menu item on the same level
↓-KEY	switches to the next menu item on the same level
MENU-IN KEY	Selects the desired menu item, steps down one menu level deeper or activates an item on the previous menu level.
MENU-OUT KEY	Terminates the entry and takes over the settings made Then steps up one menu level higher During numerical entry, takeover of the former settings

Table: General menu control

The structure of the menu is described in the following table:

1 MATHEMATICS	2 CONFIGURE	3 DEVICE
1*Offset $Ofs=x-a$ $a=+0.0000000E+0$ 2 ax+b $Lin = ax + b$ $a=+0.0000000E+0$ $b=+0.0000000E+0$ 3 Ratio $Rto = x / a$ $a=+0.0000000E+0$ 4 %Deviation $Dev=100(x-a)/a$ $a=+0.0000000E+0$ 5 dB .. 6 dBm	1 Start Mode 2 Filter 1*Auto Filter 2 Fast Auto Filt 3 Avrg Filt 3 Settings 1 Save Settings 2 Load Fact. Set 4 Calibration 1 Enter Value 2 Store Cal. 3 Load Cal. 4 Load Fact. Cal	1 Contrast N 2 Interface 1 IEEE-488 1 Address 2 * RS233 1 Xon/Xoff 2 RTS / CTS 3* no Handshake 3. Command Set 1. 5017 2. 6048 / 6047 3. 6001 / 5001 / 4001 3 Temp Sensor 1 Pt10 2 Pt25 3* Pt100 4 Pt500 5 Pt1000 4* Beeper 5 Display 1*Settings 2 Math 3 Channel 4 Sec Counter 6 Scanner 1* 4-pole, 20 CH 2 2-pole, 40 CH 3 1-pole, 80 CH

Table: Menu structure

The ‘*’ sign means that this menu item is activated.

4.9 Mathematical Programs

The mathematical programs are used to convert the displayed measurement reading according to a specified formula.

Selection / Manual Control

The manual control procedure is as follows:

	Keypress	Display / Action
1.	MENU-IN KEY	1 MATH E M A T H E M A T I C S . . If this display does not appear, press the \uparrow -KEY until it appears.
2.	MENU-IN KEY	1 * a x + b . . The asterisk means that this program is selected.
3.	\downarrow -KEY / \uparrow -KEY	Press repeatedly until the desired mathematical program appears in the display.
4.	MENU-IN KEY	1 * L i n = a x + b Describes the conversion formula of the program (or press the $\downarrow\uparrow$ KEYS until the formula appears)
5.	\downarrow -KEY	a = + 0 . 0 0 0 0 0 0 0 0 E + 0 Switches to input mode for the constant
6.	MENU-IN KEY	a = + 0 . 0 0 0 0 0 0 0 0 E + 0 Numerical entry possible. The digit is selected with the $\downarrow\uparrow$ -KEYS (see blue legend)
7.	MENU-OUT KEY	Terminates the entry without takeover of the number entered.
8.	MENU-IN KEY	Takes over the entry.
9.	\downarrow -KEY	Selects further constants, if any.
10.	MENU-OUT KEY	Steps up one menu level higher.
11.	MATH KEY	Activates / deactivates the previously selected mathematical program.

Table: Selecting a mathematical program

The input of the constants have to be in the displayed unit and not in the physical unit. For example you want to calculate in the resistance measurement, range 3 k Ω and the constant is '5000.000' please enter 5.000.

Meaning of the Mathematical Programs

Mathematical Program	Conversion	Meaning
1 Offset (Ofs)	Display = $x - a$	Subtraction of a constant
2 $ax+b$ (Lin)	Display = $ax + b$	Linearization of the measuring range
3 Ratio (Rto)	Display = x / a	Ratio display
4 %Deviation (Dev)	Display = $100 (x - a) / a$	Percentage deviation of the measurement reading from a constant
5 dB ..	Display = $20 \log (x/a)$	Ratio of the measurement to a constant voltage (current) a in decibels
6 dBm	Display = $20 \log (x/e)$ $e = 0.775V$ or 1.29 mA	Ratio of the measurement to a voltage (current) corresponding to 1mW into a load impedance of 600Ω

Table: Meaning of the mathematical programs

4.10 The Menu "Configure"

Start Mode / Trigger Mode

This menu activates start mode. Triggering can be performed manually or via the external trigger socket.

	Keypress	Display / Action
1.	MENU-IN KEY	2 CONFIGURE . . If this display does not appear, press the ↑-KEY until it appears.
2.	MENU-IN KEY	1 Start Mode . .
3.	MENU-IN KEY	1 * Start Mode . . activates / deactivates start mode.
4.	MENU-OUT KEY	Takes over the entry and steps up one menu level higher; press repeatedly to reach the measurement display
5.	TRIG: 2 X 2ND-KEY	Measurement of a value is started manually

Table: Selecting start mode

Filter

To increase disturbance suppression for better stability of the measurement readings, the input signals can be passed through a digital filter which operates as moving average filter for the last ten readings. After the first ten readings have come into the filter loop, each new reading thereafter replaces the oldest one.

Two filters are available:

- Automatic average value filter (Auto Filter)
- Fast Automatic average value filter (Fast Auto Filter)
- Moving average filter (Avg. Filter)

Automatic Filter (Auto Filter)

The **automatic filter** calculates the moving average over ten readings and additionally the difference between the last two successive readings, comparing this result with a difference value preset in the factory (depending on measuring range, function and time). The filtering process is restarted when the difference exceeds the value preset in the factory.

The filtering process also restarts when function, range or measuring time are reselected.

Fast Automatic Filter (Fast Auto Filter)

similar to the automatic filter, but the first value after switching of channels or ranges is more stable.

Moving Average Filter (Avg. Filter)

The **moving average filter** operates according to the same principle as above but does not permit any signal-dependent restarting of the filter loop.

This filter is restarted when a function, range or measuring time is selected and after pressing the FILTER KEY.

This kind of filtering achieves additional disturbance suppression by more than 20 dB.

Filter Selection

	Keypress	Display / Action
1.	MENU-IN KEY	2 CONFIGURE.. If this display does not appear, press the ↑-KEY until it does appear.
2.	MENU-IN KEY	2 Filter..
3.	MENU-IN KEY	1 * Auto Filter Activates / deactivates the automatic filter with the MENU-IN KEY.
4.	↓-KEY	3 * Avg. Filter Activates / deactivates the average value filter with the MENU-IN KEY.
5.	MENU-OUT KEY	Takes over the entry, then steps up one menu level higher. Press repeatedly to reach the measurement reading display.

Table: Filter selection

Saving and Loading Instrument Settings

The menu item "Settings" permits saving of a power-up status or loading of factory settings.

	Keypress	Display / Action
1.	MENU-IN KEY	2 CONFIGURE.. If this display does not appear, press the ↑-KEY until it does appear.
2.	MENU-IN KEY	3 Settings..
3.	MENU-IN KEY	1 Save Settings Saves the present instrument settings as power-up status on pressing the MENU-IN KEY.
4.	↓-KEY	2 Load Fact. Set Loads the factory settings on pressing the MENU-IN KEY.

Table: Saving the instrument settings and loading factory settings

Power-Up Status

The following information items are saved in the power-up status:

- The measuring function for each channel
- The measuring range for each channel
- The measuring time (resolution) for each channel
- The filter setting
- The scanner mode
- The mathematical program and constants
- The temperature sensor
- The LCD contrast

The measurement range and measurement time are stored during operation for each function, but this information is lost when switching off the instrument.

Calibration

Described in the chapter headed "Calibration".

4.11 The Menu "Device"

Technical hardware settings such as temperature sensor, interface preselection, LCD contrast and scanner setting are made in this menu.

Setting the Contrast

	Keypress	Display / Action
1.	MENU-IN KEY	3 Device . . If this display does not appear, press the ↓-KEY until it does appear.
2.	MENU-IN KEY	1 Contrast : 6 If this display does not appear, press the ↑-KEY until it does appear.
3.	MENU-IN KEY	Switches-on entry mode.
4.	↑-KEY	Increases the contrast by one unit.
5.	↓-KEY	Decreases the contrast by one unit.
6.	MENU-OUT KEY	Takes over the entry and steps up one menu level higher. Press repeatedly to reach the measurement reading display.

Table: Setting the contrast

The contrast can be adjusted over the range from 1 to 9 units.

Preselecting the Interface

The 5017 is equipped with a RS232 serial data interface and the IEEE-488 interface. The interface which is to be activated can be set in this menu.

	Keypress	Display / Action
1.	MENU-IN KEY	3 Device .. If this display does not appear, press the ↓-KEY until it does appear.
2.	MENU-IN KEY	2 Interface .. If this display does not appear, press the ↑↓-KEYS until it does appear.
3.	MENU-IN KEY	1 IEEE - 488 .. The IEEE488 interface is selected with the MENU-IN KEY.
4.	MENU-IN-KEY	1 Address 14 Enter the device address and then to terminate the entry press the MENU-IN KEY.
5.	MENU-OUT KEY	Takes over the entry and steps up one menu level higher. Press repeatedly to reach the measurement reading display.

Table: Setting the IEEE-488 interface

	Keypress	Display / Action
1.	MENU-IN KEY	3 Device .. If this display does not appear, press the ↓-KEY until it does appear.
2.	MENU-IN KEY	2 Interface .. If this display does not appear, press the ↑↓-KEYS until it does appear.
3.	MENU-IN KEY	2 RS232 .. The RS232 interface is selected with the MENU-IN KEY.
4.	MENU-IN KEY	1 Xon / Xoff Select the handshake mode and then press the MENU-IN KEY to confirm.
5.	MENU-OUT KEY	Takes over the entry and steps up one menu level higher. Press repeatedly to reach the measurement reading display.

Table: Setting the RS232 interface

The possible handshake modes for the RS232 interface are:

- Xon / Xoff
- RTS / CTS (needs a special cable, see 'Accessories' No. 3017)
- no Handshake

Preselecting the Command Set for Remote Control

The 5017 can be remoted with different command sets:

- 5017
- 6048 / 6047
- 6001 / 5001 / 4001 (6½ digit)

	Keypress	Display / Action
1.	MENU-IN KEY	3 Device . . If this display does not appear, press the ↓-KEY until it does appear.
2.	MENU-IN KEY	2 Interface . . If this display does not appear, press the ↑↓-KEYS until it does appear.
3.	MENU-IN KEY	3 Command Set . . The command set can be with the MENU-IN KEY.
4.	MENU-IN KEY	3 6001 / 5001 / 4001 Select the command set and then press the MENU-IN KEY to confirm.
5.	MENU-OUT KEY	Takes over the entry and steps up one menu level higher. Press repeatedly to reach the measurement reading display.

Table: Setting the command set

See chapter 'Remote Control' for more information.

Selecting the Temperature Sensor

You have the choice between several different platinum resistance thermometer sensors:

Pt10, Pt25, Pt100, Pt500, Pt1000.

	Keypress	Display / Action
1.	MENU-IN KEY	3 Device.. If this display does not appear, press the ↓-KEY until it does appear.
2.	MENU-IN KEY	3 Temp Sensor.. If this display does not appear, press the ↑↓-KEYS until it does appear
3.	MENU-IN KEY	1 Pt100 Select the desired sensor with the ↑↓-KEYS.
4.	MENU-IN KEY	1 * Pt100 Activates the selected sensor.
5.	MENU-OUT KEY	Takes over the entry and steps up one menu level higher. Press repeatedly to reach the measurement reading display.

Table: Selecting the temperature sensor

Activating the Loudspeaker

	Keypress	Display / Action
1.	MENU-IN KEY	3 Device.. If this display does not appear, press the ↓-KEY until it does appear.
2.	MENU-IN-KEY	4 Beeper If this display does not appear, press the ↑↓-KEY until it does appear.
3.	MENU-IN KEY	4 * Beeper The loudspeaker is now active. Every keystroke generates a BEEP. Proceed the same way to deactivate the loudspeaker again.
4.	MENU-OUT KEY	Takes over the entry and steps up one menu level higher. Press repeatedly to reach the measurement reading display.

Table: Activating the loudspeaker

Setting the Display Formats

	Keypress	Display / Action
1.	MENU-IN KEY	3 Device.. If this display does not appear, press the ↓-KEY until it does appear.
2.	MENU-IN KEY	5 Display.. If this display does not appear, press the ↑↓-KEYS until it does appear.
3.	MENU-IN KEY	1 Mathematics Select the desired display format with the ↑↓-KEYS.
4.	MENU-IN KEY	1 * Mathematics Activates / deactivates the selected format.
5.	MENU-OUT KEY	Takes over the entry and then steps up one menu level higher. Press repeatedly to reach the measurement reading display.

Table: Setting the display format

The following display formats can be selected:

1 Mathematics

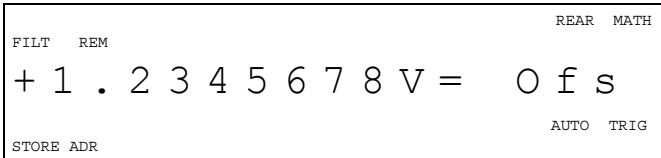

Condition: Mathematical program is switched on.

2 Channel

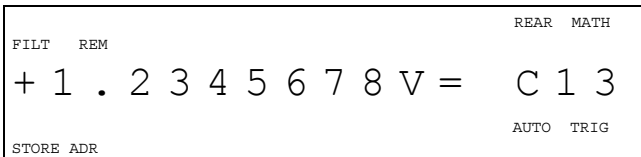

Condition: 5017SC and internal connector plugged into scanner.

3 Sec. Counter (Measuring time counter)

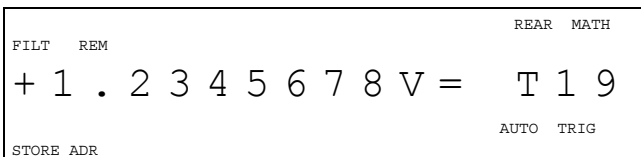

Condition: Measuring time 4 s or longer

If the conditions are not fulfilled, a display with these settings is shown:

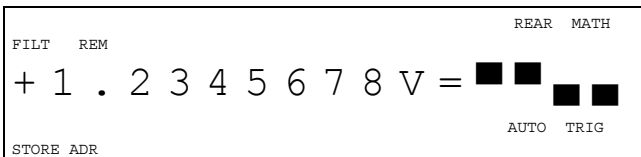

Please read chapter 3, "Quick Start" for a detailed description of the meanings of the settings.

Setting the Scanner Mode

	Keypress	Display / Action
1.	MENU-IN KEY	3 Device . . If this display does not appear, press the ↓-KEY until it does appear.
2.	MENU-IN KEY	6 Scanner . . If this display does not appear, press the ↑↓-KEYS until it does appear.
3.	MENU-IN KEY	1 4 - pole , 20 CH Select the desired mode with the ↑↓-KEYS.
4.	MENU-IN KEY	1 * 4 - pole , 20 CH Activates the selected mode.
5.	MENU-OUT KEY	Takes over the entry and then steps up one menu level higher. Press repeatedly to reach the measurement reading display.

Table: Setting the scanner mode

The following scanner modes can be set:

- 4-pole, 20 channels
- 2-pole, 40 channels
- 1-pole, 80 channels

The pinout of the 50-pole Sub-D plug connector of the measuring points scanner is contained in chapter "Technical Specifications".

4.12 Error Messages

Overflow	Measuring range overflow
Sensor?	Resistance of the sensor overshoots/undershoots the defined range
Div/0	Division by zero in a mathematical function
Br. wires	Open source line in 4-wire resistance measurement
Offset too high	Offset too large after pressing the zero key
Polarity?	$\Omega/4$: Source or Sense are not connected with the right polarity
Cal. Error	Calibration error
reading too low	Measurement reading too small
value too low	Value too small
value too high	Value too large
not mathematics	Not for mathematics
not temperature	Not for temperature measurement
Scanner Mode?	Scanner mode unsuitable
Front Input Only	Only at front sockets (e.g. current measurement)
invalid PIN	Invalid PIN number for calibration

5 Remote Control

This chapter describes operation of the 5017 via the IEEE-488 and RS232 interface in remotely controlled measuring systems.

This instrument supports both interface types: IEEE-488 and RS232

5.1 Configuration

Some manual configurations must be made to enable operation of the 5017 via one of the two interfaces IEEE-488 or RS232.

All necessary settings are made in the menu "Device, Interface".

- Select interface (RS232, IEEE-488)
- Assign device address for IEEE-488
- Set handshake mode for RS232
- Set the command set (standard is '5017')

Select Interface

Select the interface with which the instrument is to be controlled in the menu "Device, Interface" (see chapter "Manual Operation").

The 5017 is equipped in the standard version with the two most common interfaces used in measuring systems, namely IEEE-488 and RS232.

Configuring the RS232 Interface

Transmission via the RS232 interface takes place with 8N1 format, i.e. a data word has 8 bits, no parity bit and one stop bit. The transmission speed is fixed at 9600 Bd.

Handshake Mode

The 5017 permits setting of various handshake modes so that this instrument can communicate with numerous RS232 control programs. Many programming languages and the Windows terminal program use XON/XOFF handshake. A special RS232 cable (zero modem cable, see chapter 'Accessories' No. 3017) is required for RTS/CTS handshake, but very fast and reliable data transmission is possible then.

End Detection under RS232

The end of a transmitted or received message is designated with a line feed character "LF" in RS232 data transmission.

Configuring the IEEE-488 Interface

The device address and the terminator character of the messages (ASCII strings) are of importance for programming and data transmission in communication between the control computer and the 5017. The IEEE address can be assigned by the user, but the terminator is fixed and defined by the 488.2 standard.

Setting the IEEE-488, Device Address

The device address is set via the menu "Device, Interface, IEEE488" (see chapter "Manual Operation") and can be saved in the power-up status. The device address set in the factory is 7.

End Detection in the IEEE-488, Message Transmission

When operating with the IEEE488 interface, the standard string terminators are used for reception and transmission of messages (ASCII strings), namely "LF+EOI". "LF" stands for "Line Feed" and "EOI" designates an interface line which is set by hardware control.

Define the Command Set

Different command sets can be selected. In this way the 5017 can replace the DMMs 6047/6048 and 6001/5001/4001 and work with the same software. Please chapter 'Compatibility' for special remarks and restrictions of the compatibility.

5.2 General Information concerning Remote Control

All functions which can be manually controlled via the keyboard can also be remotely controlled, except for the device address assignment which can only be set via the keyboard.

As soon as the instrument has received the first command via the interface, the keyboard is disabled for manual control of the instrument functions. Manual control via the keyboard is thereafter possible again after pressing the LOCAL-BUTTON. In remote control mode the designator "Rem" is lit in the right window of the main display.

The instrument understands up to 30 characters in a command. All characters are ASCII characters. Several commands can be combined in and executed from a single string of characters sent as one message (e.g. "VDR5A1"), but some commands must be sent at the end of a string, as 'NVxxxxxxxx', 'Cnx', 'Slx', 'D1...' and the '?-commands'.

The specific commands for controlling data transmission via the interface are contained in the manual for the utilized IEEE bus interface and some are specific to the programming language used.

Any space characters (SPACE, ASCII code 20H) contained in the character string sent by the computer are ignored.

The instrument can receive commands (operation as LISTENER) and it can also send device messages concerning its status (operation as TALKER). In this status the indication "ADR" appears on the very right in the display.

The time when the instrument transmits messages can be defined by the computer. One possibility is for the computer to address the instrument as TALKER, and then read-out the device message. The second possibility is to operate the instrument in SRQ (service request) mode. It then requests service from the computer when a status change has taken place. Switchover to SRQ mode can be made with a command. The basic status of the instrument after power-up is without SRQ

5.3 Special Features for the RS232 Interface

The DMM 5017 is directly sending measurement values when opening the RS232 interface. If this is not wanted, the command 'CN0' can be send from the PC. Then the instrument sends only a measurement value, if 'RD?' comes from the PC.

5.4 Capabilities of the IEEE-488 Bus Interface

The IEEE computer interface has the following capabilities defined by the IEEE-488 standard:

SH 1	Handshake source function
AH 1	Handshake sink function
T6	TALKER function
L3	LISTENER function
RL1	Remote control
DC1	Reset function
DT1	Initiate function
SR1	Service request function

General IEEE-488.1 Messages

The instrument understands the universal commands DCL, SPE and SPD. The command DCL (device clear) brings the instrument into its basic state (V dc, 300V). Of the addressed commands it understands GET, GTL, LLO and SDC.

The commands have the following effects:

DCL	Device Clear	Sets the instrument to the basic state
SDC	Selected Device Clear	Sets the instrument to the basic state
GTL	Go To Local	Terminates remote control status
LLO	Local Lock Out	The instrument cannot be switched to manual control via the local button (keyboard lockout)
SPE	Serial Poll Enable	Prepares for serial polling
SPD	Serial Poll Disable	Terminates serial polling
GET	Group Execute Trigger	Initiates a trigger for the addressed devices
UNT	UnTalk	Addressing cancellation - is not displayed
UNL	UnListen	Addressing - is not displayed
PPC, PPU, TCT		not supported

5.5 RS232 / IEEE-488.2 Common Commands

In addition to the 488.1 commands, the 5017 also understands common commands according to the IEEE-488.2 standard that can be used with both interfaces RS232 and IEEE-488.

The common commands are transmitted to the 5017 as ASCII character string which must always start with an asterisk "*".

The following commands are implemented in the 5017:

*CLS	Clear Status Byte (command)
*ESE	Standard Event Status Enable (command)
*ESE?	Standard Event Status Enable (query)
*ESR?	Standard Event Status Register (query)
*IDN?	Identification (query)
*OPC	Operation Completed (command)
*OPC?	Operation Completed (query)
*RST	Reset (command)
*SRE	Service Request Enable (command)
*SRE?	Service Request Enable (query)
*STB?	Read Status Byte (query) <i>see description</i>
*TST?	Self Test (query)
*WAI	Wait To Continue (command)

***CLS, Clear Status Command**

The command *"*CLS"* resets the status byte and the error queue. The Enable, Event, ESE and SRE registers are not reset.

***ESE Standard Event Status Enable Command**

The command "**ESE <Number>* " sets the contents of the Standard Event Enable Register (event register mask). The parameters thereby have no effect.

Number Meaning for the Standard Event Enable Register

0	Resets the register
1	(Bit 1) Service Request
2	(Bit 0) Operation Completed (OPC) is set
4	(Bit 2) Query Error (QYE) is set
8	(Bit 3) Device Dependent Error (DDE) is set
16	(Bit 4) Execution Error (EXE) is set
32	(Bit 5) Command Error (CME) is set
64	(Bit 6) User Request (URQ) is set
128	(Bit 7) Power On (PON) is set

***ESE? Standard Event Status Enable Query**

The command "**ESE?*" reads out the mask set in the Standard Event Enable Register.

The reply is a decimal value whose binary meaning is as stated above.

***ESR? Standard Event Status Register Query**

The command "**ESR?*" reads the current contents of the Standard Event Status Register. The contents of this register are written directly by the instrument according to a certain event. After read-out this register is reset to 0.

***IDN? Identification Query**

The command *"*IDN?"* queries the identification designation of the 5017. Read-out produces a character string with the following format:

```
"PREMA GmbH,5017 DIGITAL MULTIMETER,0,<year>-<week>-<Number>"
with  <year>    =    Year of software version
      <week>    =    Week of software version
      <Number>  =    No. of software version
```

For example:

```
"PREMA GmbH,5017 DIGITAL MULTIMETER,0,97-10-01"
```

***OPC Operation Completed Command**

The command *"*OPC"* sets the Operation Completed bit (Bit 0) of the Standard Event Status Register after all currently running command sequences have been executed completely.

***OPC? Operation Completed Query**

The command *"*OPC?"* makes the instrument write an ASCII 1 into the output buffer if all currently running operations have been completed.

***RST Reset Command**

The command *"*RST"* executes a reset of the 5017. The instrument thereby takes the default setting (*RST). All still running internal operations are aborted, but no registers are reset.

***SRE Service Request Enable Command**

The command *"*SRE <Number>"* sets the mask for the Service Request Enable Register. The individual numbers here have the following meaning:

Decimal value	Contents of the Service Request Enable Register
0	Resets the register.
1	(Bit 0), sets measurement value
2	(Bit 1), sets Error message like "Overflow", "Sensor?", "Div/0"
4	(Bit 2), sets Error Available (EAV)
16	(Bit 4), sets Message Available (MAV).
32	(Bit 5), sets Event Summary Bit (ESB).
128	(Bit 7), sets button pressed

Bit 3 and 6 are not assigned.

***SRE? Service Request Enable Query**

The command *"*SRE?"* reads the contents of the Service Request Enable Register. The meaning of the contents of this register is as described above for the **SRE* command.

***STB? Read Status Byte Query**

The command *"*STB?"* reads out the status byte of the 5017. The value of the Status Byte is always 0, because the measurement value is set back after a new command. Use SRQ if you want to check when a measurement value is available.

Decimal value	Meaning in the status byte register
1	(Bit 0), Measurement Value available
2	(Bit 1), Error like "Overflow", "Sensor?", "Div/0" occurred
4	(Bit 2), Error Queue.
16	(Bit 4), Message Queue.
32	(Bit 5), Event Summary Bit (ESB).
64	(Bit 6), Master Summary Status (MSS)/ Request Service (RQS)
128	(Bit 7), Button pressed

Bit 3 is not assigned.

To determine exactly what events have taken place, query the corresponding status registers. For example, if Bit 5 (ESB) is set, the cause can be determined with the command "**ESR?*".

For the IEEE488 interface, setting of Bit 6 activates the SRQ line so that the controller card in the computer can respond.

***TST? Self Test Query**

The command "**TST?*" interrogates the result of the power-up self test of the instrument. The reply is "0" if the self test was completed without error. If any other value is obtained, please contact PREMA GmbH.

***WAI Wait-to-Continue Command**

The command "**WAI*" prevents execution of further commands until the operations of a previous command have been completed.

5.6 Structure of the Registers

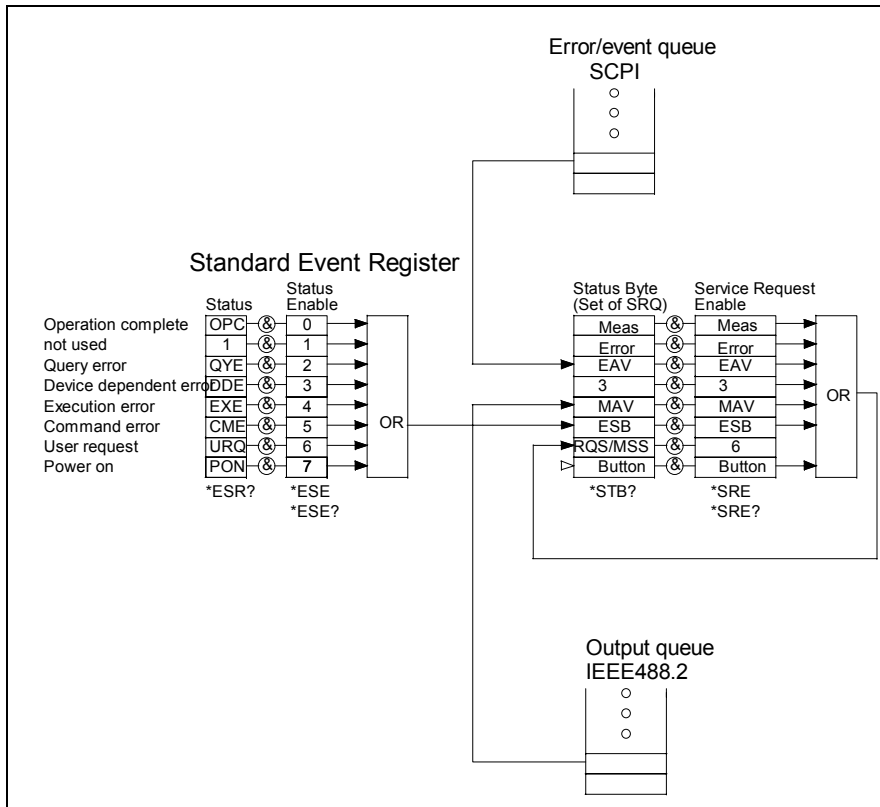

5.7 Operation as Listener

The instrument must be addressed as LISTENER to prepare it for receiving commands. The instructions for doing this are contained in the user manual of the computer manufacturer. The segment 'ADR' in the right window of the display is lit when the instrument has been addressed as LISTENER.

The instrument understands the following commands:

- MR** Measuring mode. The measurement reading is selected and appears in the display of the digital multimeter and in the character string of the TALKER function.
- CR** Calculating mode. The calculation result of the selected program appears in the display of the digital multimeter and in the character string of the TALKER function.
- Cx** Entry of constants,
Format x: Constant No., Sign, Constant value
x = 0: Constant a, x = 1: Constant b Example: C1+3.45678912E+6
Constants has to be entered in the displayed unit, not in the physical unit.
- VD** Direct voltage Vdc
- VA** Alternating voltage Vac
- VC** Alternating voltage + Direct voltage component Vac + dc
- O2** 2-wire resistance measurement $\Omega 2W$
- O4** 4-wire resistance measurement $\Omega 4W$
- ID** Direct current Idc
- IA** Alternating current Iac
- IC** Alternating current + Direct current component Iac + dc
- TC** Temperature measurement in °C
- TF** Temperature measurement in °F

- TK** Temperature measurement in K
- SLx** Selection of the temperature sensor with
- | | | | |
|-------|------|-------|--------|
| x = 1 | Pt10 | x = 3 | Pt100 |
| x = 2 | Pt25 | x = 4 | Pt500 |
| | | x = 5 | Pt1000 |
- SL?** Query of the currently set temperature sensor
- FQ** Frequency
- PD** Period duration
- CO** Continuity check
- Pxx** Program selection with
- | | |
|---------|-------------|
| xx = 01 | Offset |
| xx = 02 | ax + b |
| xx = 03 | Ratio |
| xx = 04 | % Deviation |
| xx = 05 | dB |
| xx = 06 | dBm |
- A0** (A/zero) Autoranging off
- A1** Switches autoranging on
- Rx** Measuring range selection with
- | | |
|-------|-----------------------------------|
| x = 1 | 300mV, 300 Ω , 200 μ A |
| x = 2 | 3V, 3 k Ω , 2mA |
| x = 3 | 30V, 30 k Ω , 20 mA |
| x = 4 | 300V, 300 k Ω , 200 mA |
| x = 5 | 1000V, 3 M Ω , 2 A |
| x = 6 | 30 M Ω |

Tx	Integration time / Measuring time selection with			
	x = 0	20ms	x = 6	2 s
	x = 1	40ms	x = 7	4 s
	x = 2	100ms	x = 8	10 s
	x = 3	200ms	x = 9	20 s
	x = 4	400ms	x = A	40 s
	x = 5	1 s	x = B	100 s
	x = Z	10ms (only for frequency measurement)		

D0	(D/zero) Display mode switch-off
-----------	----------------------------------

D1“text“	Display mode switch-on. A text sent after “D1“ is output to the display of the multimeter. The internal display is switched off. The text sent must be enclosed between quote characters.
-----------------	---

F0	(F/zero) switches off the additional filter.
F1	Switches on the average value filter (Avg. Filter).
F2	Switches on the automatic filter (Auto Filter).
F3	Switches on the fast automatic filter (Fast Auto Filter).

Q0	(Q/zero) switches off SRQ mode.
Q1	Switches on SRQ mode on: - every new measurement reading - error message - reset - out of limit

EQ?	Query of the Error-Queue
------------	--------------------------

S0	(S/zero) start mode off, continuous sequence of measurements on
S1	Start mode on; every S1 command starts a measurement
S2	Start mode on, start with trigger line or trigger button

- L0** (L/zero) short format; the multimeter outputs only the first message unit (measurement data and text messages).
- L1** Long format; the multimeter outputs both message units (measurement data/text messages and programing data).
- ZO** (Zeppelin/Otto) Offset correction on
- Mxx** Selects a scanner channel
with xx = 01 to 80
- MPx** Scanner mode with
x = 1 1-pole, 80 channels
x = 2 2-pole, 40 channels
x = 4 4-pole, 20 channels
- NVxxxxxxxx** Calibration, calibration string transfer
After NV the multimeter expects a 9-digit unsigned integer decimal number as nominal value for the calibration via the interface. A nominal value must be transmitted alone, i.e. no other command from the table above may be contained in the same string. The digital multimeter starts the calibration after transmission of the nominal value.
- NV“ppppppp“** Entry of the calibration 7-digit PIN number
- Ix** Contrast setting with x = 0 9
- RD?** READ?, reads out the current measurement reading
(esp. used for RS232 interface)
- CNx** x = 0 Continuous mode off (esp. used for RS232 interface)
x = 1 Continuous mode on

5.8 Display Mode

In display mode the computer can output text messages to the display of the instrument irrespective of other functions of the instrument.

Display mode is switched on with D1. The ASCII characters following thereafter are written to the display. All ASCII characters for which a segment code is defined in the ASCII segment table are displayed. All other characters produce a blank (dark)

character position. All superfluous characters present after D1 and the output text are ignored. If D1 "text" is sent together with other commands in the same character string, it must be the last command in the character chain.

D0 switches display mode off again and the display according to the active operating mode and function appears.

5.9 String Length Selection

The digital multimeter can send different length messages to the computer whereby the desired message length is selected with L0 or L1. The latest measurement reading is returned if the computer sends the command L0. The status information is not output in response to L0. In response to L1 the instrument sends the most recent data including the status information.

5.10 SRQ Mode

If the digital multimeter is not to be continually interrogated by the computer but instead the digital multimeter is to request service from the computer when a status change has taken place, SRQ mode (service request) must be switched on with the command Q1.

A SRQ is sent, for example, when keyboard input has been made, when error messages appear. Utilization of SRQ mode requires that the connected computer can recognize a SRQ and reply to it with a serial poll (see computer manual).

5.11 Operation of the Digital Multimeter as TALKER

On request by the computer, the instrument sends a message containing its present status and the most recent measurement reading. For this purpose the computer must address the instrument as TALKER. The instructions how to do this are contained in the manual of the computer manufacturer. The message 'ADR' is lit in the right window of the display when the instrument has been addressed as TALKER.

The transmitted message consists of a character string and a fixed terminator at the end of each character string enabling the computer to recognize the end of the transmission. The message consists of two message units. The first unit contains the data of the most recent measurement reading or calculation result, and the second unit contains data concerning the programing status. The two message units are transmitted as complete data record. The string terminator is fixed and defined with IEEE-488.2 standard as "LF + EOI".

The ASCII (ISO 7 bit) code is used for the transmission.

The length of the second message unit is fixed and always consists of 27 characters plus the terminator character. The length of the first message unit is 14 characters for output of measurement readings and calculation results.

Only the first message unit is transmitted when the short string is requested (command "L0"). The status information (2nd message unit) is not sent in this case.

Description of the Message Record Sent

The following table gives an overview of the possible lengths of the message record depending on the selected operating mode.

A message record consists of one (short string format) or of two (long string format) message units, followed by a terminator character. The second message unit is called the status information.

40 characters + terminator character

Example: +01.298764E+0MRVDP00A0R2F0T2D0S0Q0MOFB00"+ Terminator

or in short string format (13 characters)

+01.298764E+0" + Terminator

Example:

ERROR 01 MR04P00A1R6F0T2D0S0Q0MOFB00"+ Terminator

ERROR 01 + Terminator

The numbers in brackets (..) apply for the number of characters in short string format.

The measurement reading or a text message appears in the first message unit.

Text messages are ERROR x, NULL, CAL.

Character positions not required are filled with blanks.

The second message unit (status information) commences at the 14th character.

Table of Device Messages sent by the Multimeter

The device message outputs the following characters to designate the instrument status or the instrument settings:

1st character	14th character	40th character + End
!	!	!
+x.xxxxxxxxxxE+xMRVDPxxAxRxTxDxSxQxMxxB00		
- 000000000	-0CRVA 01 0 1 0 0 0 0 0 0 01 01	
0	: VC 02 1 : 1 : 1 1 1 : :	
.....	: ID 03 : 2 : : :	
.....	: IA 04 : 3 : : :	
999999999	7 O2 6 9 80 17	
	O4 A	
	TC B	
	TK	
	TF	
	TF	
	PD	
	FQ	
	CO	
ERROR xx		
CAL		
(-----) (-----)		
1st message unit	2nd message unit	

Meaning of the Transmitted Characters

Position	(first, last character) of the device message
(1, 1)	"+" positive sign of the mantissa "- " negative sign of the mantissa
(2, 10)	"x" 8-digit mantissa or text message, Numerical range ".00000000 - 99999999"
(11, 11)	"E" Designates the exponent
(12, 12)	"+" positive sign of the exponent "- " negative sign of the exponent
(13, 13)	"x" Magnitude of the exponent
(14, 15)	"MR" Measurement reading is output "CR" Calculation result is output "Cx" Constant No. x is output
(16, 17)	"VD" Direct voltage measurement "VA" Alternating voltage measurement "VC" Alternating voltage with direct voltage component "ID" Direct current measurement "IA" Alternating current measurement "IC" Alternating current measurement with direct current component "O2" Resistance measurement, two-wire configuration "O4" Resistance measurement, four-wire configuration "TC" Temperature measurement, display in °C "TF" Temperature measurement, display in °Fahrenheit "TK" Temperature measurement, display in Kelvin "FQ" Frequency measurement "PD" Period duration measurement "CO" Continuity check

(18, 20) "Pxx" Mathematical program No. xx selected
 "P01" Offset
 "P02" $ax + b$
 "P03" Ratio
 "P04" % Deviation
 "P05" dB
 "P06" dBm

(21, 22) "A0" Autoranging switched off
 "A1" Autoranging switched on

(23, 24) "Rx" Measuring range "x" is set
 x = 1 300mV, 300 Ω , 200 μ A
 x = 2 3V, 3 k Ω , 2mA
 x = 3 30V, 30 k Ω , 20 mA
 x = 4 300V, 300 k Ω , 200 mA
 x = 5 1000V, 3 M Ω , 2 A
 x = 6 30 M Ω

(25, 26) "Fx" Filter selection
 x=0 Filter off
 x=1 Average value filter on
 x=2 Automatic filter on
 x=3 Fast Automatic Filter on

(27, 28) "Tx" Integration time "x" is set
 TZ 10 msec for frequency measurement only
 T0 20 msec 5 ½ digits
 T1 40 msec 5 ½ digits
 T2 100 msec 5 ½ digits
 T3 200 msec 6 ½ digits
 T4 400 msec 6 ½ digits
 T5 1 sec 6 ½ digits
 T6 2 sec 7 ½ digits
 T7 4 sec 7 ½ digits
 T8 10 sec 7 ½ digits
 T9 20 sec 7 ½ digits
 TA 40 sec 7 ½ digits
 TB 100 sec 7 ½ digits

- (29, 30) "Dx" Display mode
x=0 Display mode switched off
x=1 Display mode switched on
- (31, 32) "Sx" Start mode
x=0 Start mode switched off
x=1 Start mode switched on
x=2 Start mode on, start with trigger line or button
- (33, 34) "Qx" Service request function
x=0 SERVICE-REQUEST function switched off
x=1 SRQ active
- (35, 37) "Mxx" Channel selection
Channel "xx" switched on
- (38, 40) "Bxx" Button No.xx has been pressed, B00: no button pressed.
Numbering of the buttons on the front panel:
- | | | | | | | | | |
|----|---|---|---|---|----|----|----|----|
| | 1 | 2 | 3 | 4 | 5 | 11 | 12 | 13 |
| 17 | 6 | 7 | 8 | 9 | 10 | 14 | 15 | 16 |

5.12 Error Messages

Error 01	Overflow Sensor?	Measuring range overflow Resistance of the sensor overshoots/undershoots the defined range
Error 02	Div/0	Division by zero in a mathematical function
Error 03	Br. wires	Open source line in 4-wire resistance measurement
Error 04	Offset too high	Offset too large after pressing the zero key (302)
Error 05	Cal. Error	Calibration error (341-343)
Error 07	Polarity?	for RTD or Ω , sense or source wrong polarity
Error 10	not mathematics	Not for mathematics (303)
Error 11	not temperature	Not for temperature measurement (304)
Error 12	Scanner Mode?	Scanner mode unsuitable (305)
Error 13	Front Input Only	Only at front sockets (e.g. current measurement) (306)
Error 14	invalid PIN	Invalid PIN number for calibration (307)

Values in brackets (only error message 04 to 14) appear when reading out the error queue. Error message 01 to 03 are send instead of the measurement value.

5.13 Compatibility

The customer can also select a command set which is compatible to the DMM 4001/5001/6001 or to the DMM 6047 / 6048 in the menu 'Device', 'Interface', 'Command Set'.

5017 as Listener

5017	6001/4001	6047	Remarks
VD	VD	VD	
VA	VA	VA	
VC	-	VC	
O2	O2	O2	
O4	O4	O4	
ID	ID	ID	NOT through Scanner inputs
IA	IA	IA	NOT through Scanner inputs
IC	-	IC	
TC	TC	TC	
TF	TF	TF	
TK	TK	TK	
SLx	-	-	
SL?	-	-	
FQ	-	-	
PD	-	-	
CO	-	-	
R1	R1	R1	different range limits
R2	R2	R2	
R3	R3	R3	
R4	R4	R4	
R5	R5	R5	
R6	R6	R6	
A0	A0	A0	
A1	A1	A1	

5017	6001	6047	Remarks
T0	-	T0	20 ms
T1	T1	T1	40 ms (6001 50 ms)
T2	T2	T2	100 ms
T3	-	T3	200 ms
T4	T3	T4	400 ms (6001 500 ms)
T5	T4	T5	1 s
T6	-	T6	2 s
T7	T5	T7	4 s (6001 5s)
T8	T6	T8	10 s
T9	-	T9	20 s
TA	-	TA	40 s
TB	-	TB	100 s (6047 80 s)
D0	D0	D0	
D1'text'	D1text	D1text	
F0	PF	F0	all filter off (6047: Avg. filter off)
F1	-	F1	Averaging filter on
F2	P0	P00	Automatic filter on
Q0	Q0	Q0	
Q1	Q1	Q1	conditions incompatible (see status byte)
S0	S0	S0	
S1	S1	S1	only one reading is started
ZO	ZO	ZO	No automatic zero correction
L0	L0	L0	
L1	L1	L1	
M01 - M10	M0 - M9	M00 - M09	
M11 - M20	-	M10 - M19	
M20	MO	MOF	M20 instead of front panel input
NVxx..x	NVxx..x	NVxx..x	7, 8 or 9 characters
NV"pp..p"	-	-	PIN no. has to be entered manually
lx	lx	-	only 0...7 with 6001
*IDN?	ID?	-	6001 sends back 'DMM 5017'

Table: Compatibility for 6001 and 6047/6048 as listener

Non Compatible

- Math programs
- Memory ('STxx', 'RCxx')
- Analog Display ('AF')

5017 as Talker**The first message unit**

DMM	Length	Remarks	6001/6048 compatible	
5017	13	format as displayed	123.45678E+0	123.45678E+0
6001	12	in basic units	123.4567E+0	1.234567E+2
6048	14	in basic units	123.456789E+0	1.23456789E+2

The 5017 sends the reading as shown in the display also when 6001 or 6048 compatible command set is selected.

The second message unit

5017 - e.g.: MRVDP00A0R2F0T2D0S0Q0M01B00

6001 - e.g.: VDR1A0T1S0Q0MOP0D0B0

6047 - e.g.: MRVDP00A0R2F0T2D0S0Q0M01B00

The string terminator

The string terminator is fixed on LF + EOI

The ERROR messages

Error No.	5017	6001	6047	remarks
Error 01	Overflow	Overflow	Error 01	compatible
Error 02	DIV/0	Comp. Error	Error 02	compatible
Error 03	Br-Wires	-	Error 03	incompatible
Error 04	Offs Err	Offset too large	Error 04	compatible
Error 05	Cal. Err	Cal. Error	Error 05	compatible

All other ERROR messages are not compatible or do not exist.

The Statusbyte

BitNo.	5017	6001	6047	remarks
0	EOC	EOC	EOC	Bit-compatible, EOC = End of Conversion
1	Error	-	-	
2	EQ	-	-	
3	-	Error	Error	Bit-compatible
4	MAV	-	-	incompatible
5	ESB	-	-	incompatible
6	RQS	RQS	RQS	Bit-compatible
7	Button	Button	Button	Bit-compatible

Bit compatibility results only on querying solely the respective bit.
 The decimal value of the status byte is **incompatible**.

Selecting function, range and integration time

The range and the integration time are stored separately for every function, function range and integration time are stored for every channel.

IEEE commands to select the DMM type

‘dmm6001’ to select 6001 / 5001 / 4001 command set
 ‘dmm6047’ to select 6048 / 6047 command set
 ‘dmm5017’ to select 5017 command set

Difference between 5017 and 6001 concerning hardware

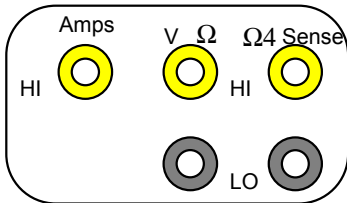
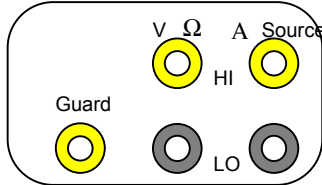
Function	DMM 5017 / 5017SC	DMM 6001 / 6001SC, 4001/4001SC
Display	7½ digit for Vdc and Ohms LCD	6½ digit LED matrix
Full scale	30 100 000 for Vdc and Ohms	1 999 999
Additional	frequency / period / continuity	-
AC Measurements	AC and AC+DC frequency range 3 Hz up to 1MHz	only AC + DC frequency range 20 Hz up to 100 kHz
Overload Limit	V/Lo-plug against ground: 250V 5017SC V/Hi to Lo: 1000V	V/Lo-plug against ground: 125V 6001-01 V/Hi to Lo: 125V
NMRR	>100dB (PLL inside)	60dB
Integration Times	from 20ms to 100s (6½ dgt from 0.2 s)	from 50 ms to 10s (6½ dgt. from 1s)
Current Ranges	Five: from 200µA to 2A	Two ranges: 2mA / 2 A
Resistance	up to 30MΩ 2- and 4-wire	2-wire max. 16 MΩ, 4 wire 100kΩ
Temperature	Pt10/Pt25/PT100/Pt500/Pt1000	Pt100
Memory	-	100 values volatile
Trigger	with trigger line (9-pole sub D connector) or keystroke	with trigger line (3.5 mm jack plug)
Interface	IEEE488, RS232	IEEE488
Filter	switchable on/off or automatic	-
Analog display	-	100 dots
Math programs	Offset, ax+b, Ratio, % Deviation	Offset, %Dev, Incr, Ratio, dB, dBm
Front plugs		
Rear plugs	Yes	No
Switch Front/Rear	manually, with open the instrument	Relay (with IEEE command or key board)
Optional Scanner	20x4-pole, 40x2-pole, 80x1-pole on two 50-pole sub D connector different pin assignment No current measurement	10x4-pole on one 50-pole sub D connector different pin assignment current measurement possible

*) DMM 5001/ 5001SC is compatible to the DMM 6001/6001 excluding Temperature and 4-wire Ohms measurement

6 Calibration

6.1 Calibration Periods

PREMA recommends that the unit be calibrated after **one year** has elapsed. Within that year, specification data are guaranteed to be valid.

6.2 PREMA Calibration Service

You can have your unit calibrated by PREMA or by a local calibration lab. Call the telephone number indicated on the front of the manual, in order to obtain information about the price and duration of this service. We make every effort to return the unit to your use as quickly as possible. In addition, when we perform a full calibration, you receive a factory certificate.

Calibrations with an official certificate can also be obtained from PREMA.

6.3 Necessary Equipment

The following aids should be available to you, in order to be able to carry out a complete calibration of the unit:

- Multifunction Calibrator for DC Voltage, DC Current, AC Voltage, AC Current, and Resistance to at least $100\text{M}\Omega$, with a minimum resolution of $6\frac{1}{2}$ digits (e.g. Datron 4800), or
- Voltage Standards (e.g. Fluke 732A, 10V) and Resistance Standards and
- Short-Circuit Terminators (three of them, e.g. PREMA 3016 Short-Circuit Terminator Set) in order to perform the zero correction.
- Connection cables with gold-plated Banana Plugs (e.g. PREMA 3014 or 3015, Precision Cable Set)

As an alternative you can also utilize less precise sources with good short-time stability; the value of the source can be checked with PREMA's $8\frac{1}{2}$ digit DMM 6048. You can then enter the DMM 6048's reading into the 5017 as calibration value.

With this method, even $5\frac{1}{2}$ digit calibrators can be used to calibrate $7\frac{1}{2}$ digit multimeters.

6.4 Automated Calibration

The calibration of the 5017 can be automated with a computer and a Multifunction Calibrator.

All measurement functions can be remotely controlled by the computer, through a special command set (for more information see chapter “Remote Control”).

Calibration can normally be carried out entirely by remote control, without any need to manually adjust potentiometers or capacitors.

For a complete calibration, the following measurement functions must be calibrated:

DC Voltage	300mV, 3V, 30V, 300V, 1000V
AC Voltage	200mV, 2V, 20V, 200V, 700V
DC Current	200 μ A, 2mA, 20mA, 200mA, 2A
AC Current	200 μ A, 2mA, 20mA, 200mA, 2A
2-wire Resistance	30k Ω , 300k Ω , 3M Ω , 30M Ω
4-wire Resistance	300 Ω , 3k Ω , 30k Ω , 300k Ω , 3M Ω , 30M Ω

The measurement functions for frequency, period, temperature, and the lower 2-wire resistance are automatically calibrated through the measurement functions listed above.

All ranges of individual measurement functions must be calibrated separately. In order to properly set the zero-point, it is very important to carry out an offset correction prior to calibration on each range of each measurement function.

Even after calibration, an Offset Correction should be carried out on a regular basis, at least once a month.

6.5 Important Steps prior to Calibration

The following items must be taken care of before the calibration procedure is started:

1. The calibration environment should be at a stable temperature of at least 18°C (64.4°F), but no more than 28°C (82.4°F). Ideally, the temperature should be 23 ±1°C (73.4°F). In order to prevent erroneous measurements due to temperature fluctuations, you can wrap the connectors at the unit in a heat-insulating cloth (like a dust cloth).
2. There must be a 2-hour warm-up period before the calibration is started.
3. Make certain, that the measurement connectors are set to front operation . If the connectors are set to rear operation, switch them to front operation, as described in the chapter “Getting Started.”
5. An offset correction must be carried out for every measurement range of every measurement function.
If you are working with a multifunction calibrator, the offset correction is carried out when the unit is already connected to the calibrator, and the calibrator is set to “Zero” (the calibrator’s zero-point).
It is important, however, that the true unit zero-point be set after calibration, by using the short-circuit terminators on the 5017 front input connectors.
6. Wherever possible, use shielded cables, as short as possible, and with gold-plated connectors. In this manner, you can make certain that the thermoelectric voltage at the measurement connectors is kept as small as possible.
7. After connecting a cable, or after changing the measurement function or range, you should wait at least one minute, before the first measurement value is read.

6.6 PIN Number and Calibration Switch

Calibration can be protected against accidental or incorrect calibrations, through the use of a rear calibration switch and a special PIN number.

The calibration button is located on the rear panel, and can be pushed with a pointed object (pen, pencil, paper clip, etc.). This button can be pushed after the calibration menu has been selected. At the same time, a request to input the PIN number will appear in the display.

	Press Key	Display / Action
1.	Cal key on the rear panel	1 PIN : <u>000000</u> Enter a PIN No. (after delivery: 000000), the display shows alternating "CAL" and the reading with the correct PIN No..
2.	MENU-IN KEY	2 CONFIGURE.. if this display does not appear press the ↑ KEY until it appears
3.	MENU-IN KEY	4 Calibration.. if this display does not appear press the ↑ KEY until it appears
4.	MENU-IN KEY	1 Enter Value.. only with the right PIN No..
5.	MENU-IN KEY	V +100.0000 <u>0</u> Enter the calibration value, close with the MENU-IN KEY
6.	MENU-IN KEY	1 Enter Value.. press several times to return to the calibration input menu
7.	↓ KEY	2 Store Cal.. with afterwards pressing of the MENU-IN KEY stores durably the calibration data
8.	Cal key on the rear panel	to close the calibration procedure

Note: Item 7 is very important. If you forget to store the user calibration it is completely deleted after you switch off the instrument. Then only the factory calibration is valid.

By following the steps described above, each measurement function and measurement range is calibrated.

The following measurement functions and ranges must be calibrated:

Measurement Function	Measurement Ranges
Vdc	300mV, 3V, 30V, 300V, 1000V
Vac	200mV, 2V, 20V, 200V, 1000V
Idc	200 μ A, 2mA, 20mA, 200mA, 2A
Iac	200 μ A, 2mA, 20mA, 200mA, 2A
Ω 4W	300 Ω , 3k Ω , 30k Ω , 300k Ω , 3M Ω , 30M Ω
Ω 2W	300k Ω , 3M Ω , 30M Ω

Table: Measurement Functions to be calibrated

Vac+dc, Iac+dc, Frequency, Period and Temperature Measurement are calibrated through the measurement functions named above.

The lower resistance ranges are only calibrated in the 4-wire resistance measurement.

Changing the PIN Number

By default, the 7-digit PIN No. is set to 0000000. If you want to change this number please proceed as follows.

	Press Key	Display / Action
1.	cal key on the rear panel	1 PIN : <u>0</u> 0 0 0 0 0 0 Enter a PIN No. (default: 0000000), with correct PIN No. the display shows alternate "CAL" and the reading.
2.	cal key on the rear panel	to close the calibration
3.	cal key on the rear panel	1 PIN : <u>0</u> 0 0 0 0 0 0 Now you can enter the desired 7 digit PIN No.

Table: Changing the PIN number

6.7 Offset Correction

An offset correction must be carried out for the following measurement functions and ranges:

Measurement Function	Measurement Ranges
Vdc	300mV, 3V, 30V, 300V, 1000V
Vac	200mV, 2V, 20V, 200V, 700V
Idc	300 μ A, 3mA, 30mA, 300mA, 2A
Iac	200 μ A, 2mA, 20mA, 200mA, 2A
Ω 2W	300 Ω , 3k Ω , 30k Ω , 300k Ω , 3M Ω , 30M Ω
Ω 4W	300 Ω , 3k Ω , 30k Ω , 300k Ω , 3M Ω , 30M Ω

Table: Offset Correction for Measurement Functions

In order to eliminate thermoelectric voltage and lead resistance, and to correct the zero-point, an Offset Correction must be carried out for each measurement function.

A correction of the zero-point is possible, when the existing deviation is less than approx. 0.2% of the range's full-scale value for DC Voltage measurements, or approx. 5% for all other functions.

If the deviation is greater, the message "Offset too high" is displayed.

Offset values that are too large can be adjusted in the "Offset" Math Program.

Note: To achieve a correct zero-point alignment, a warm-up period of at least two hours should be observed.

After switching functions and ranges, you should wait for a running period of at least two measurements before carrying out an offset correction.

6.8 Calibrating DC Voltage

Offset Correction for DC Voltage

To carry out the Offset Correction for DC Voltage measurements, a short-circuit must be applied to the V- Ω front input connectors (Accessory No. 3016).

After triggering a zero-point correction by pressing the zero key, an Offset Measurement is carried out for the currently set measurement range.

Notice: If calibration is done with a calibrator, the calibrator's offset has to be corrected for at the 5017 front input correction. The cables must be properly connected between calibrator and 5017 and the calibrator set to Zero, prior to the Offset correction of the 5017. Now perform the 5017 offset correction by pressing the zero key on the front panel.

Important: After calibration is completed and the calibrator removed, another offset correction must be performed, with a short-circuit, at the 5017 front input connector as described above.

Calibration of DC Voltage

After selecting the desired measurement range, an exactly known positive or negative reference voltage source is connected to the input connectors. The voltage can be between 5% and 100% (preferably between 20% and 100%) of the display range for the measurement range in question.

If the input voltage is not in this range, an error message is displayed.

The 5017 will now display a value that should correspond to the value of the known voltage source. If the reference value deviates too much from the measured value, the measurement range must be recalibrated.

If several measurement ranges are to be calibrated, the process described above is started again for the next range.

6.9 Calibration of Resistance Ranges

Offset Correction

When zeroing two-wire resistance measurement, the $V\Omega$ -Hi and $V\Omega$ -Lo connectors should be short-circuited, by connecting a short-circuit terminator to these front input connectors, instead of the resistance to be measured.

In four-wire resistance measurement, the real offset value is determined, by using two short-circuit terminators (Accessory No. 3016) to short-circuit the $V\Omega$ -Hi and $V\Omega$ -Lo connectors first, and then the two Sense connectors. The Sense and Source connectors are then connected to each other with a third short-circuit terminator, to accomplish a four-wire short.

It is important to make certain, that the “shortest” short-circuit is created at the Sense connectors, to prevent contact resistance or pass-through resistance from being measured.

Notice: If calibration is done with a calibrator, perform a calibration offset correction as described above with DC voltage.

Important: After calibration is completed, the 5017 zero-point must be readjusted again, with short-circuits, as described above.

Calibration of Resistance

Resistance ranges should be calibrated through four-wire resistance measurement. The same calibration factors are then used for two-wire resistance measurements. Only the higher resistance ranges need to be calibrated separately in 2-wire measurement.

In addition, all of the two-wire resistance ranges can also be calibrated separately.

The zero offset correction must be performed with the ZERO key. In addition, chapter 7, ‘Operating Instructions’ should be considered, especially referring to compensation for measurement cable resistance.

Note: In 2-wire resistance measurement the V- Ω -Hi plug may not be connected to the Sense-Hi plug.

6.10 Calibration of AC Voltage

An offset correction has to be proceeded for all ranges as described for the DC voltage.

Calibration of AC Voltage measurement is carried out without DC Voltage coupling. The AC Voltage ranges should be calibrated with a Sine Voltage that has a frequency of 1kHz.

The same calibration factor is transferred for the AC Voltage function with DC Component.

In all other ways, you can proceed as with DC Voltage calibration.

6.11 Calibration of DC and AC Current

An offset correction should be carried out with open connectors. During AC Current calibration, only the function for AC Current without DC Component is calibrated.

The reference currents shall consist of DC current for the DC Current function, and of a 1kHz Sine Current for the AC Current function.

Notice: In the 2A range, the calibration current must not exceed 1A.

6.12 Calibration of Temperature

1. Preparations

a) Warmup-period: The DMM 5017 to be calibrated should have run for at least 1h.

2. TEMP-Function: ZERO Offset Correction

- a) Insert a four-wire shorting-bridge at the input of the DMM5017, i.e. shorten the four DMM 5017 Volt/Ohm-inputs - Sense and Source - HI against LO and both pairs against each other.
- b) On the DMM5017 select 1sec integration time and press the TEMP-button. The DMM5017 will then display 'Sensor ?', because ZERO Ohms as sensor input is not

specified. But performing this sequence of operations corrects for the OHM-function ZERO-offset, with the OHM-function implemented as fundamental function for the Temperature-measurement with RTDs. That means here, the DMM5017 display **'Sensor ?' is not an error !**

- c) Press the following buttons in sequence to select the RTD-type (e.g. Pt 100):
Menu/↵ A 3 Device ↵ A 3 Temp Sensor ↵ A Pt 100 ↵ Menu/OUT.
Wait for some 10min for thermal stabilization.
- d) On the DMM5017 with the TEMP-function selected perform the ZERO-offset correction by pressing the following buttons in sequence:
2nd TIME/ZERO
The DMM5017-display will now show: 'done'.

3. TEMP-Function: Calibration

- a) Remove the four-wire shorting-bridge from the DMM5017 input terminals and connect the RTD of the above selected RTD-type onto which the following calibration has to be performed.
- b) On the DMM5017 press again the TEMP-button: The actual temperature is now displayed with the EN60751 factory calibration. Wait for another some 10min for thermal stabilization.
On the DMM5017 activate the calibration mode by pressing the Cal-button on the rear. The display will now ask for the input of the PIN number (Personal Identification No.) that saves your data under this secret No.. Enter your PIN here or simply press the Menu/↵-button without entering any PIN: The DMM5017-display now starts flashing alternately 'CAL.' and the actual temperature display with the EN60751 factory calibration.
- c) Press the following buttons in sequence to recalibrate the DMM5017 TEMP-function:
Menu/↵ A 2 CONFIGURE ↵ A 4 Calibration ↵ A 1 Enter Value ↵ <> now input the new temperature calibration value here ↵
To ensure the successful recalibration the further flashing DMM5017-display now shows 'Cal.' and the recently entered temperature calibration value.
- d) Press the following buttons to permanently save the new temperature calibration value:
Menu/↵ A 2 CONFIGURE ↵ A 4 Calibration ↵ A 2 Store Cal. ↵
The DMM5017 displays 'wait...' until the data recording into the EEPROM has finished.
Then the DMM5017 starts flashing again still indicating that the calibration mode has been activated.
- e) Press the Cal-button on the rear of the DMM5017 to leave the calibration mode. The DMM5017 now displays the recalibrated temperature calibration value.

4. TEMP-Function: Extended list of RTDs

Press the following buttons in sequence to select the recently calibrated RTD, e.g. Pt100 :

Menu/↵ A 3 DEVICE ↵ A 3 Temp. Sensor ↵ A 6 **Cal.** Pt100 ↵ Menu/OUT.

Cal. Pt100 is new in this list as the USER calibrated version of a Pt100-Sensor. The DIN-EN 60751 calibrated version is still available in the menu as

A 3 Pt100 but without the addendum **Cal.**

6.13 Storing Calibration Values

Storage of calibration values is absolutely necessary to store them durably. Every calibration step is stored only temporarily, so that the files are deleted if you switch of the instrument.

If you wish to interrupt a calibration procedure and turn off the unit, you can do so, only if you store the calibration with the menu "Store Cal." before you switch off power. You could then continue the procedure the next day for example, from the point where you left off.

7 Operating Instructions

7.1 DC Voltage Measurement

Input Resistance in DC Voltage

To make use of the high linearity of the measurement process, the input resistance for voltage measurements up to 3V is set very high ($>10\text{G}\Omega$). In this range, the unit allows precise measurements, with a maximum load error of 1ppm, even at measurement objects with an internal resistance of $1\text{k}\Omega$.

In the 30V, 300V, and 1,000V ranges, for example, and with a 100Ω internal resistance in a measurement object with a resolution of 100,000, a corresponding error of one digit step occurs.

The values of the input resistance in the individual measurement ranges, and the maximum display ranges, are shown in the following table:

Range	Full Scale	Input Resistance	Maximum Resolution
300 mV	30 100 000	10 $\text{G}\Omega$	10 nV
3 V	30 100 000	10 $\text{G}\Omega$	100 nV
30 V	30 100 000	10 $\text{M}\Omega$	1 μV
300 V	30 100 000	10 $\text{M}\Omega$	10 μV
1000 V	10 100 000	10 $\text{M}\Omega$	1 mV

The influence of the source resistance is visualized in the following diagram:

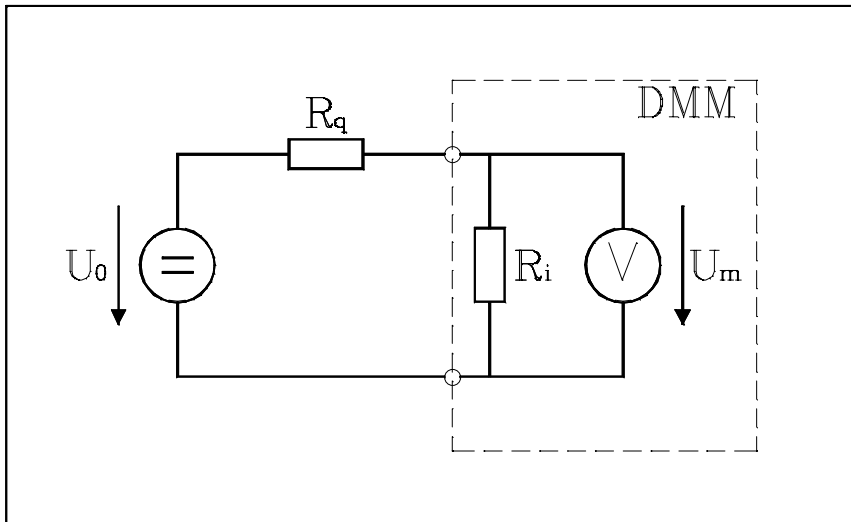

Figure: Influence of source resistance on the measurement unit

- R_i = Input Resistance of the Multimeter ($10\text{M}\Omega$ or $>1\text{G}\Omega$)
- R_q = Source Resistance of the Measurement Object
- U_o = Voltage of the Measurement Object

The error, in %, of a measurement, is calculated as follows:

$$\text{Error}(\%) = \frac{100 \times R_q}{R_q + R_i} \quad \text{Example: } R_i \geq 1\text{G}\Omega; R_q = 10\text{k}\Omega$$

$$\text{Error} = 0.0001\% \text{ (1 ppm)}$$

The error rating, in ppm (parts per million), often used in measurement technology, is derived from: $\text{Error}(\%) \times 10,000$.

Series Mode Suppression

One of the main advantages of the integrating measurement process lies in the high suppression of series AC voltage components (e.g. main line scatter), which are overlaid on the actual signal voltage. For frequencies, where the measurement time is an integer multiple of the period length, an infinitely high noise suppression level theoretically results.

Short-term fluctuations of the mains frequency would lead to measurement errors in case of fixed measurement times.

That is why, in the 5017 a PLL circuit (Phase Locked Loop) is used to synchronize the measurement time with the period of the main line frequency. An integer multiple of the mains period is always contained in the measurement time.

Due to the fully integrating measurement process, the positive and negative half-waves of line voltage are neutralized. Line scatter can thereby be completely suppressed.

The 5017 achieves a Series Mode Suppression of >100 dB with line frequencies of $50 / 60\text{Hz} \pm 5\%$.

Common Mode Suppression

The ability of a measurement device, to display only the desired differential signal between the “HI” and “LO” inputs, while suppressing an equal voltage on both clamps against ground, is designated as Common Mode Suppression. In an ideal system, no errors would be generated, but in real life, scatter capacitances, isolation resistances, and non-symmetrical resistances convert a part of the common mode voltage into a series voltage.

Common mode suppression in the 5017 is more than 160dB, with a non-symmetry of 1kOhm in the leads.

Thermal Voltages

One of the most common error sources in DC Voltage measurement in the low signal range is the thermal voltage produced by thermal EMF.

These thermal voltages occur at the contact points of different metals that are at the same or different temperature levels.

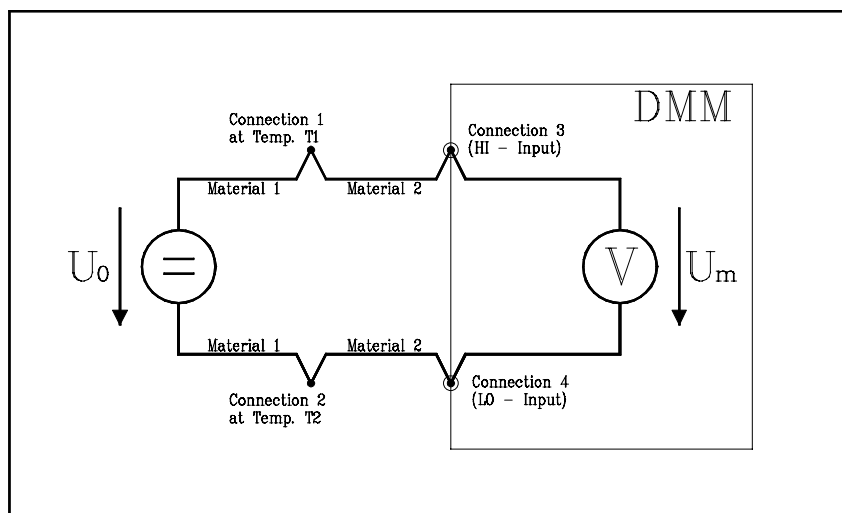

Diagram: Thermal Voltage sources in a measurement circuit

The sketch shows the possible thermal voltage sources in a measurement circuit, which can exist at an external connection point (Contact 1/2), but can also occur in the connectors of the measurement unit.

It is always important to carry out all connections with the same material, or at least to use materials, that produce very small thermal voltages, when they are put in contact with each other.

The table below shows the different thermal voltages for diverse material combinations:

Contact Materials	approx. Thermal Voltage
Cu - Cu	$< 0,3\mu/\text{°C}$
Cu - Ag (Silver)	$0,4\mu/\text{°C}$
Cu - Au (Gold)	$0,4\mu/\text{°C}$
Cu - Sn (Tin)	$2-4\mu/\text{°C}$ (dep. on composition)

For example, if material 1 consists of a silver lead and material 2 consists of a copper cable, a connection between contacts 1 and 2 at a temperature difference of just 1°C already results in a thermoelectric voltage of 400nV . In the smallest voltage range, with a resolution of $7\frac{1}{2}$ digits (10nV sensitivity), this would result in an error of ± 40 digits.

Noise Effects Through Inductive Interferences

If the measurement leads are located near changing magnetic fields, generated for example by a nearby high-voltage line, induction will cause an interfering voltage in series with the measurement voltage.

By using twisted pair measurement leads, inductive interferences by a magnetic field can be very strongly reduced. One should also take care not to allow the leads to hang around loosely and move around during measurements, since that can cause error voltages.

An additional measure for the reduction of noise is to increase the distance to the magnetic field, or if possible to shield measurements from it.

7.2 Resistance Measurement

The resistance measurements of the 5017 are carried out through the DC Current method in a 2-wire or 4-wire connection.

A constant current (I) is forced through the resistance to be measured (R); the same current simultaneously flows through a known internal range resistance. The voltage drop across the resistance R is measured, and its relationship to the voltage drop across the internal range resistance is noted. In this manner, resistance measurement is not influenced by aging or drifting of the reference voltage source.

Two-Wire Resistance Measurement

If resistance measurements are carried out in two-wire mode, then it is important to do a careful compensation for lead resistances and thermal voltages, through the use of the offset correction procedure, especially when measuring small resistances ($< 1\text{k}\Omega$). To do this, the two measurement cables are connected by their clamps, producing a short circuit, then an Offset Correction is triggered with the ZERO key. Potential error sources, like lead resistance, contact resistance, and thermal voltages at the connections between different metals, are thereby eliminated.

If an Offset Correction is not carried out, a measurement value R_m is obtained, which

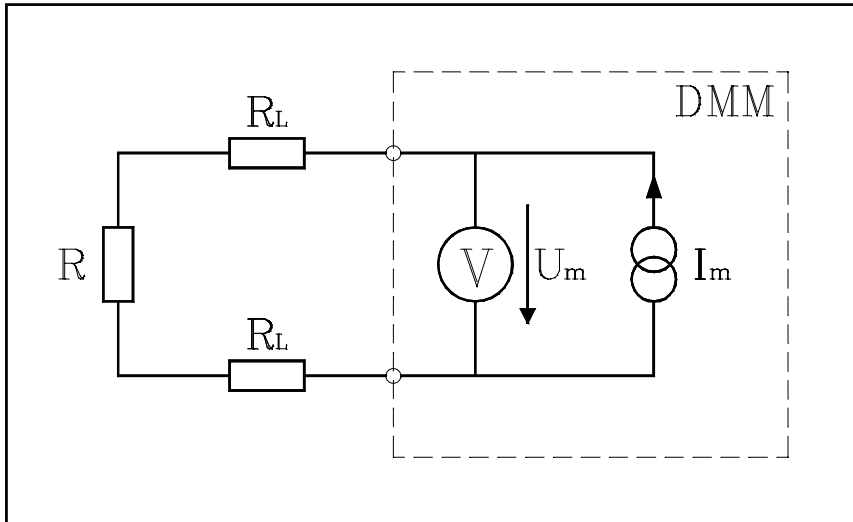

Diagram: Principle of 2-wire resistance measurement

is composed of the sum of all the resistances that exist in the measurement circuit (measurement path), and is too high by the lead resistance.

$$R_m = R + R_L + R_L$$

The measurement cables that are often used, with a length of 1m, have a resistance of approx. 10-20mΩ. If the resistance to be measured is 100Ω, this already results in an error of 0.04 %.

With low resistance values, especially in the 100 Ohm range, the lead resistance makes itself strongly visible. For that reason, a four-wire resistance measurement is recommended for these ranges.

Four-Wire Resistance Measurement

To avoid the measurement problems that are produced by lead resistance, the four-wire arrangement is used for the measurement of small resistances (see diagram below).

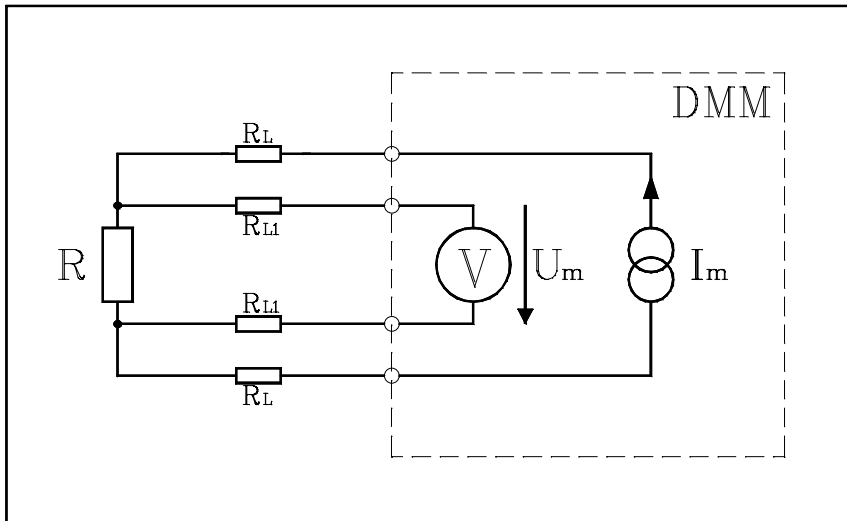

Diagram: Principle of 4-wire resistance measurement

The measurement current I_m is forced through the 'external' connections of four-wire resistance measurements into the resistance R to be measured, through the cables with the lead resistance R_L .

The measurement leads with the lead resistance R_{L1} are connected to the "Ω4W Sense-Input" of the measurement unit, which possesses a high-ohm input stage, so that a negligible voltage drop occurs at R_{L1} .

The measured voltage is therefore to be considered as proportional to the resistance value R .

ATTENTION !

In 2-wire, as well as in 4-wire resistance measurements, large resistances (starting at 100kOhm) should be measured only with shielded measurement leads, where the shielding must be connected to ground, to avoid noisy interferences through external voltages (e.g. Line Frequency).

The cables should have a very high insulation resistance (e.g. Teflon insulation) otherwise leakage current problems may occur, because R_x and the cable insulation resistance are connected in parallel.

It is also of advantage to use an integration time greater than 1s, since the greater length of measurement signal integration serves to suppress noisy scatter.

Power Dissipation in the Resistors

An error source that is often forgotten in the measurement of resistance sensors (e.g. temperature sensors), is the power dissipation in the resistances to be measured, and thereby the self-heating that is associated with it.

The measurement result can be strongly affected, especially with sensors that have high temperature coefficients. A reduction of this error is achieved through appropriate pre-selection of the measurement range.

The following table provides an overview of power dissipation at the maximum measurement value of each resistance range.

Range	Meas. Current	Power Dissipation at Full Scale
300 Ω	1 mA	300 μ W
3 k Ω	1 mA	3 mW
30 k Ω	100 μ A	300 μ W
300 k Ω	10 μ A	30 μ W
3 M Ω	1 μ A	3 μ W
30M Ω	0.1 μ A	0.3 μ W

Table: Power dissipation on resistors

7.3 AC Voltage Measurement

The 5017 Multifunction Meter offers two methods of measuring AC Voltages:

- AC Voltage as True RMS Value with DC Component
- AC Voltage as True RMS Value without DC Component

The mode Vac+dc must be activated for AC voltages with a frequency lower than 50Hz. For AC Voltage measurements, it is recommended to use a two-lead cable with shielding, with the shielding connected to ground.

Less shielding is achieved by using a simple coaxial cable.

In the 200V and 700V ranges, at high frequencies (200V range more than 100kHz, 700V range more than 10kHz), please make sure, that the applied AC Voltage does not surpass the RMS Value product of 10,000,000V x Hz.

7.4 DC and AC Current

The 5017 Multifunction Meter carries out Current measurements through the use of precise shunt resistors. The Voltage drop caused by passing the Current through the shunt is measured. As defined by the lead resistance R_L and the shunt resistance R , a burden voltage U_B is generated. Under certain conditions, this can result in erroneous measurements.

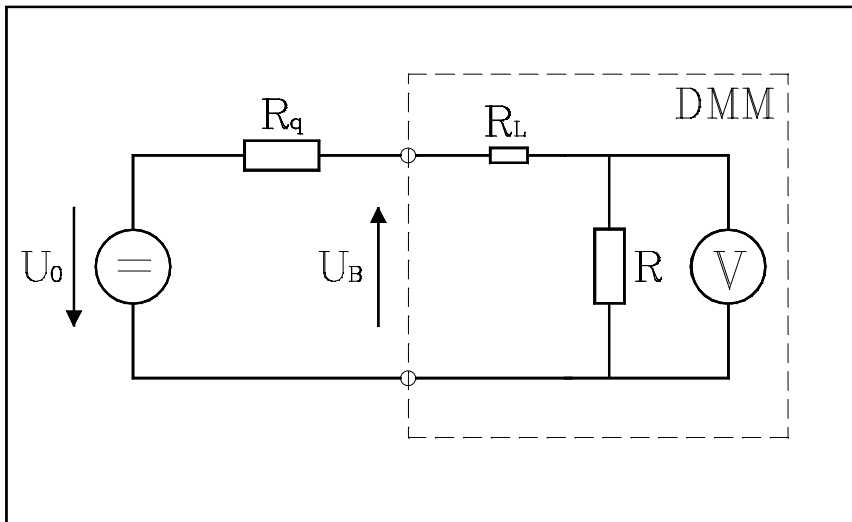

Diagram: Principle of current measurement with shunt resistors

$U_0 =$ Source Voltage

$R_q =$ Source Resistance

$U_B =$ Burden Voltage

$R =$ Shunt Resistor in Multimeter

The error, in %, for a measurement, is then calculated as follows:

$$\text{Error(\%)} = -\frac{100 \times U_B}{U_0}$$

7.5 Temperature Measurement

The temperature measurement in the 5017 can be done with different resistance thermometers (RTD, Resistance Temperature Detector).

The temperature measurements are made using the four-wire resistance function (see above in this chapter) and converting the resistance readings to temperature values.

When making the connections, it is important to observe correct polarity Hi-Hi and Lo-Lo of the measuring line (Ω -input) and of the current source (Ω -source-input).

The 5017 linearizes the temperature for Pt10, Pt25, Pt100, Pt500 and Pt1000 sensors.

Ready mounted Pt100 sensors are available from PREMA with handle and gold-plated banana plugs for four-wire connection to the 5017 (see accessories).

8 Construction

The 5017 is roughly divided into two components:

- Analog Component
- Digital Component

The bottom of the unit's case is occupied by the analog multimeter board, as well as by the scanner board. The top of the case is occupied by the digital board, including the CPU and its peripherals and the IEEE488 interface.

A metal plate between the two hardware groups serves to provide support and shielding.

8.1 Input Circuit

Input attenuation circuit has been set up along two tracks, since operation amplifiers with high input resistance and low offset current are needed for the measurement of DC values (DC voltage, DC current, resistance).

On the other hand, a fast OP with high bandwidth must be put in action for AC values.

The input circuit for DC values is implemented with a high-impedance operational amplifier, which guarantees an input resistance greater than $1\text{G}\Omega$ in the range from 300mV to 3V. It is therefore suited for highly precise DC Voltage and Resistance measurements.

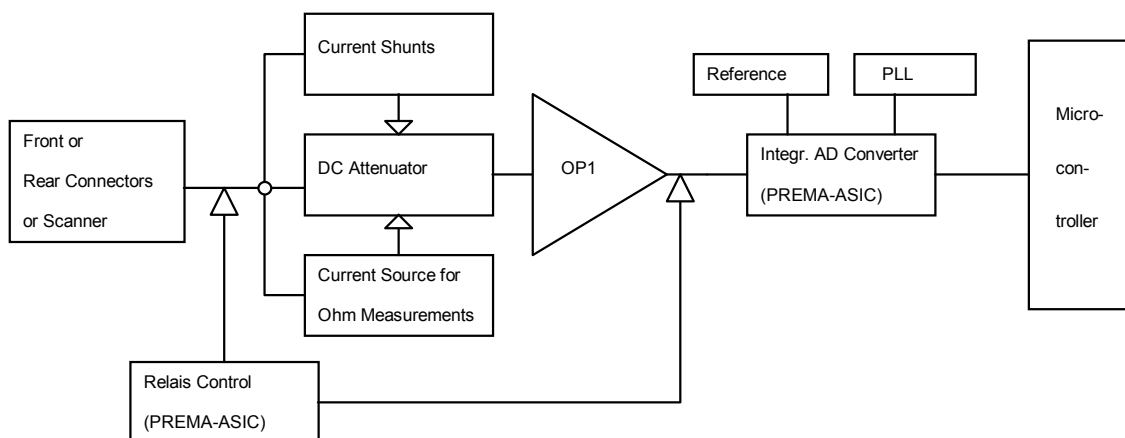

Diagram: Input Circuit for DC Values and Resistance

In order to be able to switch measurement ranges, the input circuit is also equipped with resistors and shunts.

The fast automatic ranging causes a prompt range switch (<5ms) whenever the measurement range overflows.

8.2 Integrating A to D Converter

For the highest possible resolutions, the AD converter is an integrating converter whereby the direct voltage is converted to a sequence of pulses.

The PREMA Multiple Ramp Technique for analog to digital conversion (GPD #2114141, US Patent 3765012) is the basis for a dependable Digital Multimeter with exceptional linearity and extraordinary long-term accuracy using continuous integration of the measured signal without distorting interruptions.

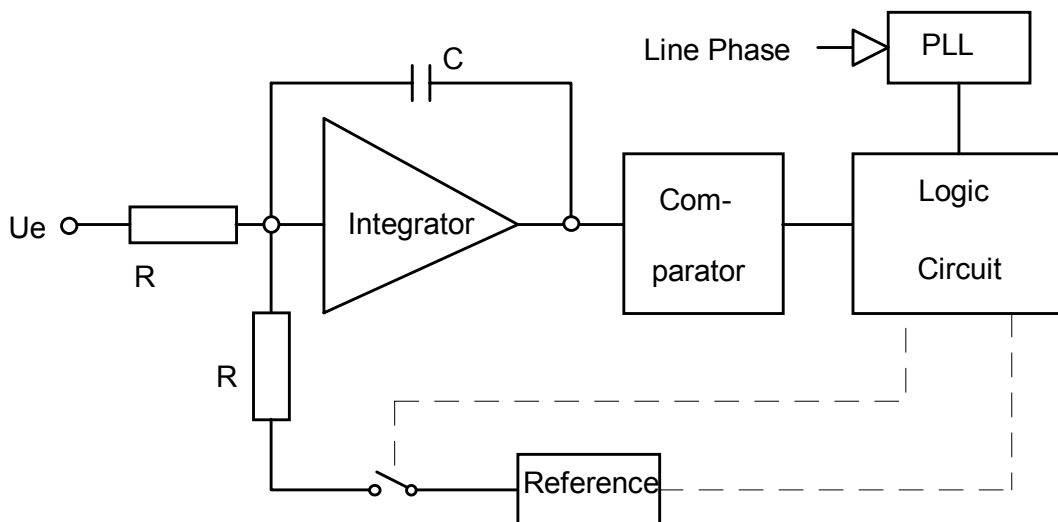

Diagram: Conceptual Circuit Diagram for "Integrating Converter"

The input current which is to be measured is applied continuously to the integrator. At periodic intervals the current from the reference voltage source with opposite polarity discharges the capacitor C .

During the discharge time the pulses of a clock oscillator are counted until the comparator detects the passage through zero and then switches off the reference current. This method of A/D conversion has high linearity, because it is not necessary to switch the measured current. Methods requiring switching of the input voltage are disturbed by the stray capacitances of the switch which cause an error depending on the input voltage and thus produce nonlinearity.

The total of all pulses counted during the entire measuring time is proportional to the average value of the input voltage.

In this kind of voltage to time conversion the result is not falsified by the loss factor of the capacitor or by drift of its capacitance value.

The result is also independent of the frequency of the clock oscillator because the times for up and down integration are determined with the same frequency.

The precision of this method essentially depends on two circuit components, the resistor in the input and the reference voltage source U_{ref} .

For the reference voltage source it is not the absolute accuracy which is important but the long term stability and low noise performance which can be optimized by selection and long term tests (aging).

The converter is composed of PREMA's customized IC, the external reference, the series resistors, and the integration capacitor.

The use of ASICs represents an important advantage here, since space is saved on the one hand, and the possibility of component failure is further reduced on the other hand.

Mains Synchronization

With an integrating converter, the synchronization between the measurement time and the period length of mains frequency is of great importance.

The reason is that, at resolutions of more than $4\frac{1}{2}$ digits, power line noise becomes noticeable in the measurement result.

With sampling converters, this line noise is often eliminated by averaging over a number of measurement results. This method greatly increases the measurement time, however, and also suppresses short-time changes in the measurement signal.

In PREMA's patented Multiple-Ramp Technique, the duration of the measurement time, as well as the phase position, is coupled to the mains voltage. This coupling is effected through a PLL Circuit (Phase-Locked-Loop), which insures that phase position and length of measurement time are always adapted to the frequency and period length of the mains voltage.

This process forms the basis for optimal suppression of power line frequency in the measurement signal.

Reference

The integrating AD converter must be wired up with an external reference. The properties of this reference ultimately determine the long-term stability of the unit.

That is why only selected components, which have been tested, and aged, over a long period of time, are put to use in the 5017.

The reference is composed of a voltage-regulating Z-Diode, heated by a resistor.

Unfortunately, references of this kind have the tendency to drift at the beginning of their operational life. After an aging process of two months, the most stable components are selected and put to use in the 5017. The absolute value of the reference voltage is of no significance, since the unit is calibrated during production.

8.3 Measurement of AC Voltage

An attenuation path was devised for the measurement of AC Voltages, which provides high band widths and sufficient measurement speed.

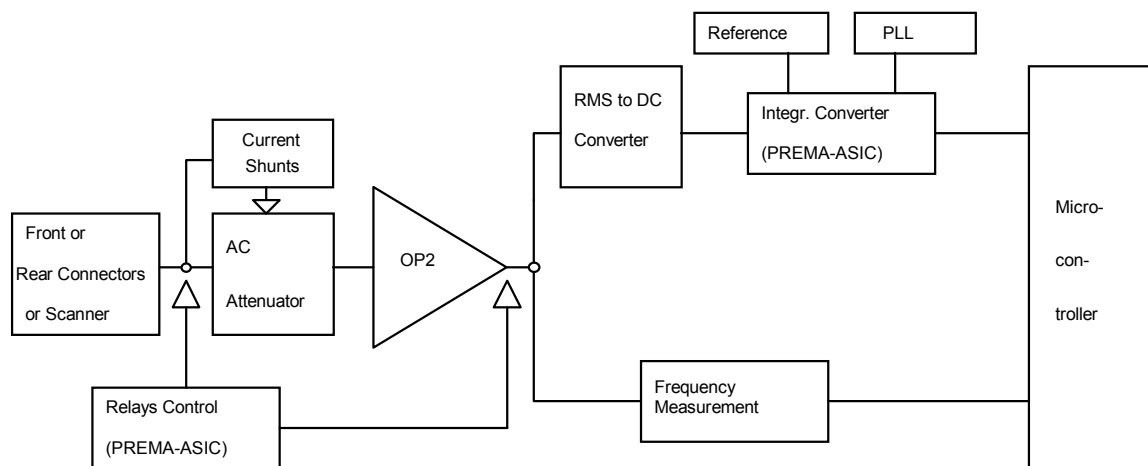

Diagram: Measurement of AC Values

Frequency, Period

Frequency and Period are primarily measured through an impulse-counting circuit. Even small frequencies can thereby be measured through the period length, with small gate times.

RMS to DC Converter

AC Voltage measurements are effected through a highly precise RMS to DC Converter. This converter determines a proportional DC Voltage from the AC Voltage being measured, equivalent to the true RMS value of the signal.

8.4 Application of Microprocessors

A variety of microprocessors come into use in the 5017.

In order to support a certain level of modularity in the individual systems, it is desirable to make the modules as autonomous as possible.

This is achieved through diverse microprocessors of varying capacities. Each module, equipped with its own processor, is therefore tested independently of other modules, through its own set of test routines.

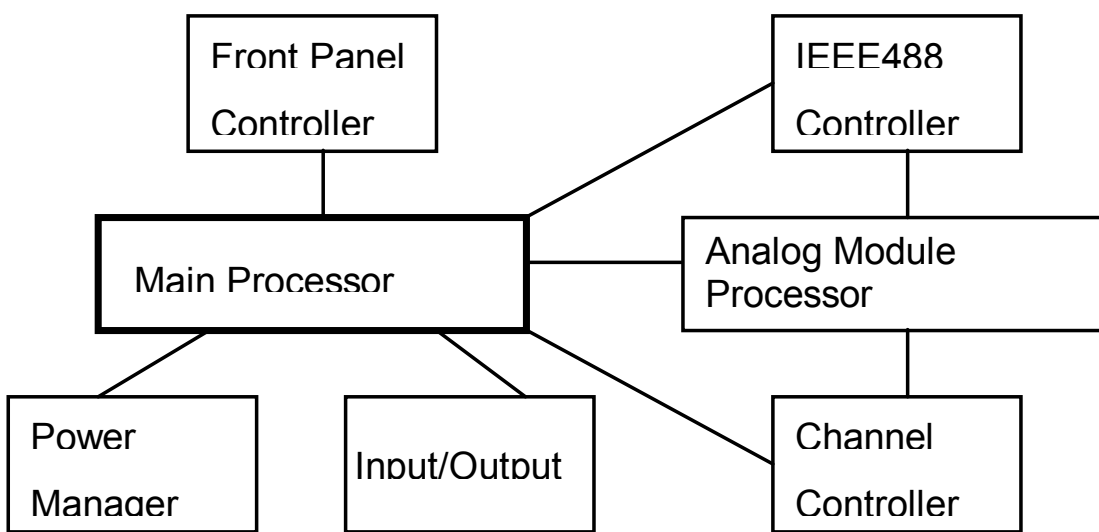

Diagram: Application of Microprocessors

This allows the error rate to be kept as small as possible, since each module has its own, independent test programs, which can operate independently from other modules, guaranteeing optimal functional security.

Another consequence of such a level of modularity is that updates are easy to carry out, and it is easier to make modifications that suit specific customer needs.

Main Processor

The main processor is a powerful 32-Bit CPU, which takes over the coordination of the various modules, as well as communication between them and supervision over them.

Power Management

The Power Management processor is directly responsible for all the functions that have to do with the incoming power voltage, as well as with the voltage supply to the individual modules.

The Standby switch has to be monitored to prevent data loss. The power manager makes sure, that all actual settings are stored in the EPROM after switch-off the 5017 with the Standby.

In addition, the power manager organizes the activation and deactivation of the LCD and the adjustment of the LCD's contrast.

Other processors

The **Front Panel Controller** assigns the appropriate functions to key presses on the front panel.

The **Analog Module's Processor** collects the accumulated measurement values, accounts for calibration and offset factors, takes care of filtering signals, and finally passes the data on to the main processor.

Switching of measurement points (80 x 1-pole, 40 x 2-pole, 20 x 4-pole) is carried out by the **Controller on the Scanner Board**. This processor receives its information about activation/deactivation of relays, and especially about timing, in part from the main processor, in part from the controller of the Analog Board.

8.5 Ports

You will find information about the connectors and their pin assignments in chapter 9, "Technical Specifications".

Display

The built-in display is an alphanumerical LC display with 16 easy to read characters. In order to improve the contrast, the display is backlit. The contrast can be set in the menu.

Memory

The complete firmware is stored into two 1Mbit EPROMS.

Serial Port

The Serial communications port is implemented as an RS232 interface with a rear panel 9-pin connector. Using the 5017 Command Set, the unit can be controlled over this interface by any PC. Functions and Ranges can be switched, and measurement data can be transferred. You will find more on this topic in chapter 9, "Remote Control."

IEEE-488 Port

This parallel interface can also be used to control the unit from a computer. In contrast to the serial RS232 interface, up to 30 units can be operated and controlled in parallel through a single IEEE-488 interface card in the PC.

Trigger Port

This port allows measurements to be started by an external trigger pulse. The port's configuration is outlined in chapter 9, "Technical Specifications".

8.6 Measurement Inputs

The 5017's front and rear panel are both equipped with five safety connectors, to which measurement signals can be connected. In order to reduce thermoelectric voltage and contact resistance, the connectors are composed of high-grade copper-tellur. For precise measurements of even the smallest voltages and resistances, you should also use measurement leads with connectors composed of copper-tellur (see Accessories).

Front / Rear Measurement Connectors

Generally, the front measurement inputs are to be connected through appropriate banana plugs. If the measurement connectors on the rear panel are needed, the internal connector board must be re-positioned. In order to do this, please proceed as described in chapter two, subparagraph 2.10, "Connection of Measurement Leads" ,” after unplugging the unit.

To protect the user, a front panel switch that would allow switching between the front panel and rear panel inputs was not implemented.

8.7 Power

A high-performance power filter connects the incoming AC mains voltage with the unit's power supply. This filter prevents any influence on measurement results from power line interference, while preventing the unit itself from causing interference to the power line, which could affect other measurement units.

8.8 5017SC

The 5017SC is equipped with a 40 channel scanner, that allows to connect up to 80 channels 1-pole to the 5017SC. The connection is provided through the two 50-pole Sub-D connectors on the rear panel of the 5017SC.

Please refer to chapter 9, "Technical Specifications" for the pin assignments.

With the 5017SC the 1000V range and any current measurement is restricted to the front plugs.

The voltage limit on the input of the scanner is max. 125 Vpk between any two pins, respectively between any pin and ground.

Scanner

The scanner operates with bistable 4-pole relays for all the switching of 20 4-pole or 40 2-pole or 80 1-pole channels.

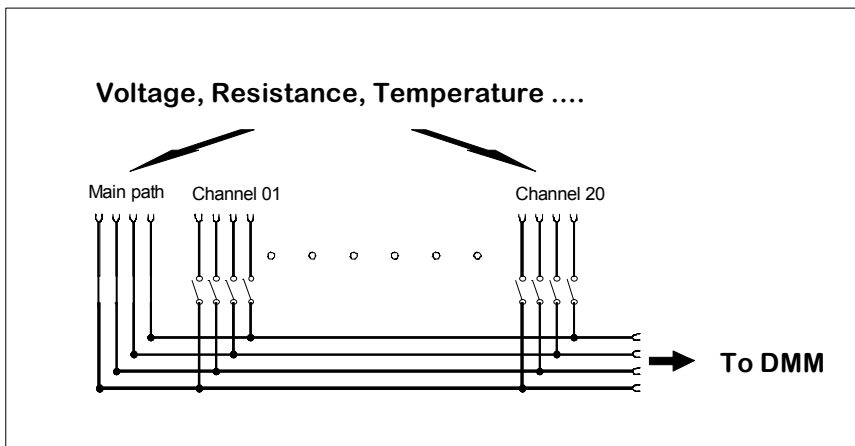

20-channel Scanner with low thermal voltage relays

The selection of the scanner configuration (1-pole, 2-pole, 4-pole) can be performed in the menu "Device, Scanner" or via remote control with the respective command.

9 Technical Specifications

All error limits and stability specifications are given according to a calibration standard traceable to the “Physikalisch Technische Bundesanstalt (PTB)” (German National Bureau of Standards). The ambient temperature at the time of calibration was $23^{\circ}\text{C} \pm 1^{\circ}\text{C}$.

Technical Specifications provided are valid when the Automatic Filter is active and when a proper offset correction has been done.

9.1 DC Voltage

RANGES $\pm 300\text{mV} / \pm 3\text{V} / \pm 30\text{V} / \pm 300\text{V} / \pm 1000\text{V}$ 2)

RANGE SELECTION manual, automatic

MEASUREMENT TIMES	Full Scale	max. Resolution
20ms / 40ms / 100ms	30 100	1 μ V
0.2s / 0.4s / 1s	3 010 000	100nV
2 / 4 / 10 / 20 / 40 / 100 s	30 100 000	10nV
1000V-Range max.	10 000 000	

STABILITY 24 Hours, $23^{\circ}\text{C} \pm 1^{\circ}\text{C}$ 1),3),4)

Range	\pm (% of Reading + % of Full Scale)	
	%Rdg.	% F.S.
$\pm 300\text{mV}$	0.0008	0.0002
$\pm 3\text{V}$	0.0004	0.0002
$\pm 30\text{V}$	0.0004	0.0002
$\pm 300\text{V}$	0.0007	0.0005
$\pm 1000\text{V}$ 2)	0.0010	0.0009

ACCURACY (1 Year) 1),3),4)

± (% of Reading + % of Full Scale)
1 Year 23°C±5°C

Range	%Rdg.	+	%F.S.
±300mV	0.003	+	0.0002
±3V	0.002	+	0.0002
±30V	0.002	+	0.0002
±300V	0.003	+	0.0004
±1000V 2)	0.004	+	0.0010

The values specified above assume that the measuring time dependent readout span is set large enough to permit readout with the accuracy stated.

A rounding error of ± 1 digit must be added to the error specified as a percentage of the maximum reading.

TEMPERATURE COEFFICIENTS

Range	(10°C-18°C / 28°C-40°C)	(0°C-10°C / 40°C-50°C)
	±(%Rdg. + %F.S.)/°C	±(%Rdg. + %F.S.)/°C
±300mV	0.0003 + 0.00015	0.0006 + 0.0003
±3V	0.0002 + 0.0001	0.0004 + 0.0002
±30V	0.0002 + 0.0001	0.0004 + 0.0002
±300V	0.0002 + 0.0001	0.0004 + 0.0002
±1000V 2)	0.0003 + 0.0001	0.0006 + 0.0002

ZERO POINT

Offset Voltage (1h warm-up time)

Temperature Coefficient	better than 0.3 μV/°C
Long-Term Stability	better than 5 μV in 90 Days

INPUT OFFSET CURRENT < ca. 20 pA at 23°C±1°C

INPUT RESISTANCE

±300mV, ±3V,	>10 GΩ 5)
±30V, ±300V, ±1000V 2)	10 MΩ

NOISE SUPPRESSION

(measured by increasing the interference peak value up to the error Reading of 1 digit, measurement time: 400ms)

Series Mode Rejection	50 / 60 Hz Mains $\pm 5\%$	> 100 dB
	50 / 60 Hz Mains $\pm 10\%$	> 50 dB

The peak value of the superimposed AC Voltage must be smaller than the DC Voltage Portion.

Common Mode Rejection	DC Voltage:	140 dB
	50Hz Mains	140 dB

(Low-Ohm connection from Shield to black "V, Ω -Lo" connector, with 1k Ω in the "Lo" Lead)

MEASUREMENT PAUSES after Range, Function, or Channel switch:
100ms

MEASURING METHOD fully integrating PREMA Multiple Ramp Method (DBP.Nr.2114141, (US-Pat. No. 3765012)

POLARITY CHANGE automatic, without measurement pause

OVERLOAD LIMITS**V/W~~H~~I against Case (Ground)**

± 1000 V Peak at 60 Hz max.
or ± 1000V DC

V/W~~H~~I against V/W~~L~~O Input

± 300mV, ± 3V	for 60 sec.	± 1000V	2)
	Continuous Load	± 700V	2)
±30V, ±300V, ±1000V	Continuous Load	± 1000V	2)

with built-in Scanner (Model 5017SC)

Front Panel Connectors			
± 300mV, ± 3V	for 60 sec.	± 1000V	2)
	Continuous Load	± 700V	2)
±30V, ±300V, ±1000V	Continuous Load	± 1000V	2)

Rear Panel Connectors

Continuous Load ± 125Vpk
with the limit $2 \cdot 10^5 \cdot V \cdot \text{Hz}$

V/W~~L~~O against Ground

250 Vdc or 250 Vpk

- 1) All values ± 1 Digit and after Offset Correction
- 2) max. 125 Vpk on rear inputs for model 5017SC
- 3) Values are valid for constant input signal; ±0,0005 % F.S. is to be added within 100 ms of a signal change.
- 4) % F.S. is related to a Reading Span of 301 000 00
- 5) Valid for input Voltage up to Full Scale.

9.2 Resistance

MEASURING METHOD..... 2-, 4-pole with DC measuring current

RANGES 300 Ω / 3 k Ω / 30 k Ω / 300 k Ω / 3 M Ω / 30 M Ω

RANGE SELECTION..... manual, automatic

MEASUREMENT TIMES	Full Scale	max. Resolution
20ms / 40ms / 100ms	301 000	1 m Ω
0.2s / 0.4s / 1s	3 010 000	100 $\mu\Omega$
2 / 4 / 10 / 20 / 40 / 100 s	30 100 000	10 $\mu\Omega$

STABILITY 24 Hours, 23°C \pm 1°C 1), 2)
 \pm (% of Reading + % of Full Scale)

Range	% Rdg.	% F.S.
300 Ω	0.001	0.0003
3k Ω	0.0004	0.0002
30k Ω	0.0004	0.0002
300k Ω	0.0006	0.0002
3M Ω	0.004	0.0003
30M Ω	0.020	0.0010

ACCURACY (1 Year, 23°C \pm 5°C) 1), 2)
 \pm (% of Reading + % of Full Scale)

Range	% Rdg.	% F.S.
300 Ω	0.003	0.0005
3k Ω	0.003	0.0004
30k Ω	0.003	0.0004
300k Ω	0.003	0.0004
3M Ω	0.007	0.0004
30M Ω	0.050	0.0010

TEMPERATURE COEFFICIENTS

Range	(10°C-18°C / 28°C-40°C) ±(%Rdg. + % F.S.)/°C	(0°C-10°C / 28°C-50°C) ±(%Rdg. + %F.S.)/°C
300Ω	0.0003 + 0.0003	0.0006 + 0.0006
3kΩ	0.0002 + 0.0002	0.0004 + 0.0004
30kΩ	0.0002 + 0.0002	0.0004 + 0.0004
300kΩ	0.0002 + 0.0002	0.0004 + 0.0004
3MΩ	0.0003 + 0.0003	0.0006 + 0.0006
30MΩ	0.0050 + 0.0005	0.0100 + 0.001

MEASURING CURRENT

Range	Measuring Current
300 Ω, 3 kΩ	1 mA
30 kΩ	100 μA
300 kΩ	10 μA
3 MΩ	1 μA
30MΩ	0.1 μA

OPEN CIRCUIT TERMINAL VOLTAGE ca. 5 V max.

MEASURING PAUSES after Range, Function, or Channel switches

300Ω to 3MΩ	100ms
30MΩ	400ms

OVERLOAD LIMIT ± 250 Vpk 3)

1) Values are ± 1 Digit and after Offset Correction

2) valid for constant input signal; ± 0,0005 % F.S. is to be added within 100 ms of a signal change.

3) Max. 125V Peak at rear panel connectors for model 5017SC

9.3 AC Voltage

CONVERSION METHOD True RMS value with DC Voltage coupling, or pure AC Voltage

RANGES 200mV/20/20V/200V/700V 3)

RANGE SELECTION..... manual, automatic

MEASURING TIMES	Full Scale	max. Resolution
100ms	199 999	1μV
0.2s - 100 s	1 999 999	100nV
Range 700V	700 000 0 3)	

ACCURACY 1 Year, 23°C ± 5°C 1), 2), 4)
 ± (% of Reading + % of Full Scale)

Range	True RMS Value			
	20Hz - 40Hz	10kHz	50kHz	100kHz - 400kHz - 1MHz
200mV	0.2+0.01 / 0.05+0.05	1.0+0.05	5.0+0.2	/
2V	0.2+0.01 / 0.05+0.01	0.1+0.02	0.5+0.1	4.5+0.4
20V	0.2+0.01 / 0.05+0.01	0.1+0.02	0.5+0.1	1.5+0.4 / 2.0+2.0
200V	0.2+0.01 / 0.05+0.01	0.1+0.02	0.5+0.1	
700V 3)	0.2+0.01 / 0.05+0.01	0.1+0.02	0.5+0.1	

DC Voltage..... ± (0.15%Rdg. + 0.2% F.S.)

TEMPERATURE COEFFICIENT

(10°C-18°C and 28°C - 40°C)

0 to 20 kHz	±(0.01% Rdg. + 0.004% F.S.)/°C
20 to 1000 kHz	±(0.04% Rdg. + 0.02% F.S.)/°C

(0°C-10°C and 40°C - 50°C)

0 to 20 kHz	±(0.02% Rdg. + 0.008% F.S.)/°C
20 to 1000 kHz	±(0.08% Rdg. + 0.04% F.S.)/°C

OVERLOAD LIMITS

V/WHI against Case	± 1000 V Peak at 60 Hz max. or ± 1000V DC Voltage	
V/WHI against V/WLO		
200mV-, 2V-Range	for 60 sec.	± 1000V Peak with the limit of $1 \cdot 10^7 \cdot V \cdot Hz$
	Continuous Load	± 700V Peak with the limit of $5 \cdot 10^6 \cdot V \cdot Hz$
20V-, 200V-, 700V-Range 3)	Continuous Load	± 1000V Peak with the limit of $1 \cdot 10^7 \cdot V \cdot Hz$
with built-in Scanner (Model 5017SC)		
Continuous Load on rear panel connectors		± 125V Peak with the limit of $2 \cdot 10^5 \cdot V \cdot Hz$

V/W~~LO~~ against Ground 250 Vdc or 250 Vpk

MEASUREMENT PAUSES	after Range, Function, or Channel Switching:	
	200mV	300ms
	2V, 20V	200ms
	200V, 700V	250ms

CREST FACTOR max. 7:1

INPUT RESISTANCE 1 MΩ in parallel >60pF

SETTLING TIME 100ms at 0.1%

1) V/Ω/LO connected to Ground, Sine Signal larger than 5% of Full Scale

2) % F.S. is always related to a Readout Span of 20 100 000

- 3) max. 100Vrms on rear panel connectors for Model 5017SC
- 4) the mode Vac+dc must be activated for AC voltages with a frequency lower than 50Hz

9.4 DC Current

RANGES $\pm 200\mu\text{A}$, $\pm 2\text{mA}$, $\pm 20\text{mA}$, $\pm 200\text{mA}$, 2A

MEASUREMENT TIMES	Full Scale	max. Resolution
20ms / 40ms / 0.1s	201 000	1 nA
0.2s - 100s	2 010 000	100 pA

STABILITY 24 Hours, $23^\circ\text{C} \pm 1^\circ\text{C}$ 1, 2)

Range	\pm (% of Reading + % of Full Scale)	
	% Rdg.	% F.S.
$\pm 200\mu\text{A}$	0.010	0.002
$\pm 2\text{mA}$	0.008	0.002
$\pm 20\text{mA}$	0.008	0.002
$\pm 200\text{mA}$	0.008	0.002
$\pm 2\text{A}$ ²⁾	0.015	0.003

ACCURACY (1 Year, $23^\circ\text{C} \pm 5^\circ\text{C}$) 1, 2)

Range	\pm (% of Reading + % of Full Scale)	
	%Rdg.	%F.S.
$\pm 200\mu\text{A}$	0.03	0.002
$\pm 2\text{mA}$	0.03	0.002
$\pm 20\text{mA}$	0.03	0.002
$\pm 200\text{mA}$	0.03	0.004
$\pm 2\text{A}$ ²⁾	0.03	0.004

The values specified above assume that the measuring time dependent readout span is set large enough to permit readout with the accuracy stated.

A rounding error of ± 1 digit must be added to the error specified as a percentage of the maximum reading.

The temperature coefficient of the offset current equals 0.5ppm of the Full Scale.

TEMPERATURE COEFFICIENT

(10°C-18°C and 28°C - 40°C) $\pm(0.001\%Rdg. + 0.0002\% F.S.)/^{\circ}C$

(0°C-10°C and 40°C - 50°C) $\pm(0.002\%Rdg. + 0.0004\% F.S.)/^{\circ}C$

BURDEN VOLTAGE AND INSTRUMENT SHUNT

Range	Burden Voltage	Instrument Shunt
200 μ A	350mV	1000 Ω
2mA	350mV	100 Ω
20 mA	350mV	10 Ω
200mA	350mV	1 Ω
2A	600mV	0.1 Ω

MEASUREMENT PAUSES

after Range, Function, or Channel switching,
100ms

OVERLOAD LIMITS

input protection
3A fast blow fuse

Personal Safety :

A-Hi against Ground	max. 60 Vpk
A-Lo against Ground	max. 60 Vpk

1) Values are ± 1 Digit and after Offset Correction, valid for constant input signal; $\pm 0,0005\%$ is to be added to F.S. within 100 ms after a signal change.

2) the specs are to be multiplied with factor 3 for currents > 1A

9.5 AC Current

CONVERSION METHOD.... True RMS value with DC Current coupling or pure AC Current

RANGES 200 μ A / 2mA / 20mA / 200mA / 2A

RANGE SELECTION..... manual, automatic

MEASUREMENT TIMES	Full Scale	max. Resolution
100ms	201 000	1nA
0.2s - 100 s	2 010 000	100pA
Range 2A	2 010 000	1 μ A

ACCURACY (1 Year, 23°C \pm 5°C) 1)

Range	\pm (% of Reading + % of Full Scale)		
	20Hz	to 40Hz	to 1kHz to 5kHz
200 μ A	0.2 + 0.01	/ 0.08 + 0.05	/ 0.2 + 0.05
2mA	0.2 + 0.01	/ 0.08 + 0.05	/ 0.1 + 0.05
20mA	0.2 + 0.01	/ 0.08 + 0.05	/ 0.1 + 0.05
200mA	0.2 + 0.01	/ 0.08 + 0.05	/ 0.1 + 0.05
2A 2)	0.2 + 0.01	/ 0.08 + 0.05	/ 0.4 + 0.05

DC Current \pm (0.15% Rdg. + 0.2% F.S.)

TEMPERATURE COEFFICIENT

(10°C-18°C and 28°C - 40°C) \pm (0.005%Rdg. + 0.001% F.S.)/°C
 (0°C-10°C and 40°C - 50°C) \pm (0.010%Rdg. + 0.002% F.S.)/°C

BURDEN VOLTAGE

Range	
200 μ A	250mV
2mA, 20mA	250mV
200mA	250mV
2A	600mV

SETTLING TIME	100ms at 0.1%
MEASUREMENT PAUSES ...	after Range, Function, or Channel switching, 300ms
OVERLOAD LIMITS	input protection (3A fast blow out fuse)
Personal Safety:	
A-Hi to Ground	max. 60Vpk
A-Lo to Ground	max. 60Vpk

- 1) Sine Signal larger than 5% of the Full Scale; V/Ω/LO connected to Ground.
 2) the specs are to be multiplied with factor 3 for currents > 1A

9.6 Temperature

MEASUREMENT METHOD	4-pole Resistance Measurement with Linearization as per EN 60751 for Pt10, Pt25, Pt100, Pt500, Pt1000	
TEMPERATURE SENSORS	Pt10 , Pt25, Pt100, Pt500, Pt1000 Platinum Resistance Sensors	
DISPLAY RANGE	Full Scale	Resolution from 1s
Celsius	- 200°C to +850°C	0.001°C
Fahrenheit	- 328°F to +1562°F	0.001°F
Kelvin	+73 K to +1123 K	0.001 K
MEASUREMENT CURRENT	Pt10/Pt25/Pt100/Pt500	1 mA
	Pt1000	100 μA

VOLTAGE ON OPEN CLAMPS ca. 5V

MEASUREMENT TIMES..... 100ms to 100s

MEASUREMENT PAUSES..... after Range, Function, or Channel switches:
100ms

ACCURACY 1)

Sensors	Stability 24h, 23±1°C ± (%Rdg. + °C)	Accuracy 1 Year, 23±5°C ± (%Rdg. + °C)
Pt10	0.002% + 0.03°C	0.007% + 0.04°C
Pt25	0.002% + 0.03°C	0.007% + 0.03°C
Pt100	0.002% + 0.03°C	0.004% + 0.02°C
Pt500	0.002% + 0.03°C	0.004% + 0.02°C
Pt1000	0.002% + 0.03°C	0.004% + 0.02°C

each case without sensor tolerance

TEMPERATURE COEFFICIENT

(10°C-18°C, 28°C-40°C)	0.009°C/°C
(0°C-10°C, 40°C-50°C)	0.018°C/°C

CALIBRATION

with Resistance Standard in Ω/4 for
 Pt10, Pt25 300Ω Range
 Pt100, Pt500 3kΩ Range
 Pt1000 30kΩ Range

1) for Measurement Times < 1s, ±0.03°C are to be added, Values are valid after offset correction.

9.7 Frequency and Period

MEASUREMENT METHOD.....	Reciprocal Enumeration Method
FREQUENCY RANGE.....	Vac: 0.2 Hz to 1 MHz Iac: 0.2 Hz to 10 kHz
PERIOD RANGE.....	Vac: 40 μ s to 5 s Iac: 100 μ s to 5 s
INPUT SIGNAL.....	Vac: 10mV rms to 700V rms Iac: 50 μ A rms to 2A rms
INPUT IMPEDANCE.....	Vac: 1 M Ω with in parallel < 60pF Iac: 0.1 Ω to 1000 Ω
RESOLUTION.....	7 Digits
ACCURACY.....	0.01% \pm 3 Digit
TIME BASE.....	5 MHz \pm 0.01%
GATE TIME.....	10ms, 100ms, 1s, 10s

9.9 Scanner with Model 5017SC

CHANNELS	80 Channels 1-pole, 40 Ch 2-pole, 20 Ch 4-pole
SWITCHING METHOD	bi-stable mechanical relays
MEAS. FUNCTIONS	Voltage, Resistance, Temp., Hz
THERMO VOLTAGE	typ. $\pm 1\mu\text{V}$, max. $2\mu\text{V}$ after 1.5h warm-up time
MAX. VOLTAGE BETWEEN 2 CONTACTS	125 Vpk with the limitation of $100\,000 * \text{V} * \text{Hz}$.
MAX. MEAS. VOLTAGE	125Vpk (also over the V/ Ω -Connector) with the limitation of $100\,000 * \text{V} * \text{Hz}$.
MAX. CONTINUITY RESISTANCE (PER LEAD)	approx. $1\ \Omega$
LIFETIME	$2 * 100\,000\,000$ Alternations (0.1 A, 10 Vdc)
ISOLATION RESISTANCE BETWEEN 2 CONTACTS	$3\ \text{G}\Omega$ at relative ambient humidity under 60%
ISOLATION RESISTANCE AGAINST CASE	$3\ \text{G}\Omega$ at relative ambient humidity under 60%
CAPACITANCE	smaller than 100 pF between the contacts
TIME BETWEEN TWO SWITCHING ACTIONS	20ms
DELAY BEFORE MEASUREMENT START AFTER CHANNEL SWITCH...	depends on Function and Range between 100ms and 500ms
ACTIVATE SCANNER	with internal socket (see Ch. „Getting Started“)

Pin Assignment of the Scanner

Scanner Input 1

Channel 4-pole	Channel 2-pole	Channel 1-pole	PIN No.	Channel 4-pole	Channel 2-pole	Channel 1-pole	PIN No.
01 SHi	01 Hi	01 Hi	19	06 SHi	11 Hi	21 Hi	25
01 SLo	01 Lo	02 Hi	18	06 SLo	11 Lo	22 Hi	24
01 Hi	02 Hi	03 Hi	35	06 Hi	12 Hi	23 Hi	9
01 Lo	02 Lo	04 Hi	34	06 Lo	12 Lo	24 Hi	8
02 SHi	03 Hi	05 Hi	4	07 SHi	13 Hi	25 Hi	27
02 SLo	03 Lo	06 Hi	3	07 SLo	13 Lo	26 Hi	26
02 Hi	04 Hi	07 Hi	2	07 Hi	14 Hi	27 Hi	11
02 Lo	04 Lo	08 Hi	1	07 Lo	14 Lo	28 Hi	10
03 SHi	05 Hi	09 Hi	21	08 SHi	15 Hi	29 Hi	29
03 SLo	05 Lo	10 Hi	20	08 SLo	15 Lo	30 Hi	28
03 Hi	06 Hi	11 Hi	37	08 Hi	16 Hi	31 Hi	13
03 Lo	06 Lo	12 Hi	36	08 Lo	16 Lo	32 Hi	12
04 SHi	07 Hi	13 Hi	5	09 SHi	17 Hi	33 Hi	31
04 SLo	07 Lo	14 Hi	22	09 SLo	17 Lo	34 Hi	30
04 Hi	08 Hi	15 Hi	39	09 Hi	18 Hi	35 Hi	15
04 Lo	08 Lo	16 Hi	38	09 Lo	18 Lo	36 Hi	14
05 SHi	09 Hi	17 Hi	7	10 SHi	19 Hi	37 Hi	33
05 SLo	09 Lo	18 Hi	6	10 SLo	19 Lo	38 Hi	32
05 Hi	10 Hi	19 Hi	40	10 Hi	20 Hi	39 Hi	17
05 Lo	10 Lo	20 Hi	23	10 Lo	20 Lo	40 Hi	16

Ground = 41, 42, 43, 44, 45 (only in 1-pole configuration)

Not Connected = 50

Output Channel = 46 (Hi), 47 (Lo), 48 (SHi), 49 (SLo) *)

SHi = Sense Hi

SLo = Sense Lo

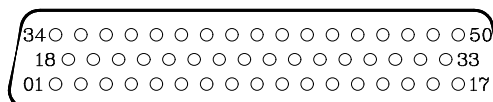

*) all lines remain connected in 1-pole or 2-pole arrangement

Scanner Input 2

Channel 4-pole	Channel 2-pole	Channel 1-pole	PIN No.	Channel 4-pole	Channel 2-pole	Channel 1-pole	PIN No.
11 SHi	21 Hi	41 Hi	19	16 SHi	31 Hi	61 Hi	25
11 SLo	21 Lo	42 Hi	18	16 SLo	31 Lo	62 Hi	24
11 Hi	22 Hi	43 Hi	35	16 Hi	32 Hi	63 Hi	9
11 Lo	22 Lo	44 Hi	34	16 Lo	32 Lo	64 Hi	8
12 SHi	23 Hi	45 Hi	4	17 SHi	33 Hi	65 Hi	27
12 SLo	23 Lo	46 Hi	3	17 SLo	33 Lo	66 Hi	26
12 Hi	24 Hi	47 Hi	2	17 Hi	34 Hi	67 Hi	11
12 Lo	24 Lo	48 Hi	1	17 Lo	34 Lo	68 Hi	10
13 SHi	25 Hi	49 Hi	21	18 SHi	35 Hi	69 Hi	29
13 SLo	25 Lo	50 Hi	20	18 SLo	35 Lo	70 Hi	28
13 Hi	26 Hi	51 Hi	37	18 Hi	36 Hi	71 Hi	13
13 Lo	26 Lo	52 Hi	36	18 Lo	36 Lo	72 Hi	12
14 SHi	27 Hi	53 Hi	5	19 SHi	37 Hi	73 Hi	31
14 SLo	27 Lo	54 Hi	22	19 SLo	37 Lo	74 Hi	30
14 Hi	28 Hi	55 Hi	39	19 Hi	38 Hi	75 Hi	15
14 Lo	28 Lo	56 Hi	38	19 Lo	38 Lo	76 Hi	14
15 SHi	29 Hi	57 Hi	7	20 SHi	39 Hi	77 Hi	33
15 SLo	29 Lo	58 Hi	6	20 SLo	39 Lo	78 Hi	32
15 Hi	30 Hi	59 Hi	40	20 Hi	40 Hi	79 Hi	17
15 Lo	30 Lo	60 Hi	23	20 Lo	40 Lo	80 Hi	16

Ground = 41, 42, 43, 44, 45 (only in 1-pole configuration)
 Not connected = 46, 47, 48, 49, 50

SHi= Sense Hi
 SLo = Sense Lo

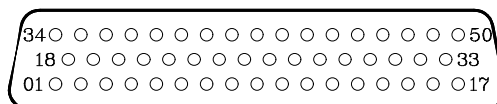

9.10 IEEE-488 Interface

OUTPUT INFORMATION	measurement result, function, range, measurement time, calculation result and other device settings.
INPUT INFORMATION	function, range, measurement time, start command, calibration set-point, math program and constants, display text and other device settings.
ADDRESS	selectable from 0 to 30, in the menu "Device, Interface, IEEE488".
SERVICE REQUEST.....	SRQ after each measurement value.
TERMINATOR	EOI Line and Line Feed
KEYBOARD	can be de-activated over REN, can be activated over GTL and over ESC/LOCAL key (lockable over LLO)
COMPATIBILITY	IEEE-488.1 and IEEE-488.2
BUS CONNECTOR.....	24-pin as per IEEE-488

PIN ASSIGNMENTS IEEE-488 INTERFACE

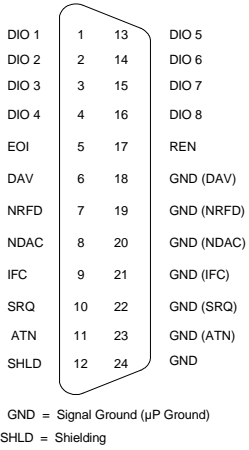

Data Bus:		
DIO 1-DIO 8	Data Bits 1-8	I/O
Data Transfer Control Bus		
DAV	Data Valid	I/O
NRFD	Not ready for Data	I/O
NDAC	No Data Accepted	I/O
Interface Control Bus:		
IFC	Interface Clear	I
ATN	Attention	I
SRQ	Service Request	O
REN	Remote Enable	I
EOI	End or Identify	I/O

Attention! Avoid any discharge of electrostatic voltages over the IEEE-488 connector, since it can lead to damage or destruction of the unit.

9.11 RS232 Serial Interface

DATA FORMAT	8N1 (8 data bits, no parity, 1 stop bit)
BAUD RATE	9600 Bd
CONNECTOR TYPE	9-pin Sub-D connector
HANDSHAKE	selectable: <ul style="list-style-type: none"> - Xon/Xoff - RTS/CTS - no handshake

PIN ASSIGNMENTS:

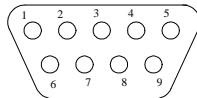

PIN-No.	Orientation	Signal	Description
1	Input	DCD (Data Carrier Detect)	
2	Input	RD (Receive Data)	Received Data
3	Output	TD (Transmit Data)	Sent Data
4	Output	DTR (Data Terminal Ready)	
5		GND	Signal Ground
6	Input	DSR (Data Set Ready)	
7	Output	RTS (Request to Send)	
8	Input	CTS (Clear to Send)	
9	Input	RI (Ring Indicator)	

Table: PIN assignment RS232

PIN Assignment RS232 Cable

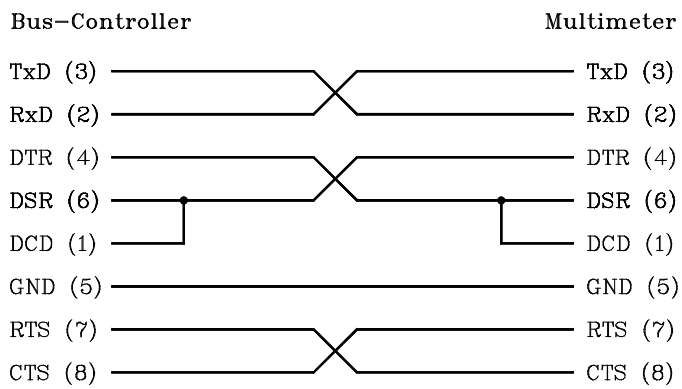

9.12 Trigger Interface

CONNECTOR TYPE	9-pin SUB-D Connector
NUMBER OF LEADS	8 lines (4 used)
INPUT VOLTAGE	Active Low
	VIH Min. -0.5V Max. 0.8V
	VIL Min. 2.0V Max. 5.5V

PIN ASSIGNMENTS OF TRIGGER INTERFACE

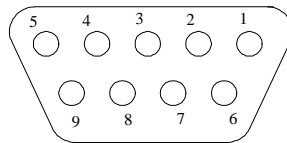

PIN	9	8	7	6	5	4	3	2
Signal	In	In	In	In	-	-	-	-
	Trigger Reading							

PIN 1 = Ground

9.13 EU Conformity

The EU Declaration of Conformity for the 5017 certifies that this multimeter conforms to the pertinent requirements of the relevant EU directives and standards.

EMC Compliance Tests

The following EMC (EMC = Electromagnetic Compatibility) compliance tests have been carried out conforming to the EMC directive 89/336/EEG. The compliance has been documented.

Measurement of the EMI Emissions

EN 50081-1

Electromagnetic Compatibility

Generic Standard Class: Residential, Commercial and Light Industry

EN 55022

Class B, Limits and methods of measurement of Radio Interference Characteristics of Information Technology Equipment (CISPR 22, modified), European Standard
Emission radiated, Frequency Range 30 MHz to 1 GHz.

EN 55022

Class B, Limits and methods of measurement of Radio Interference Characteristics of Information Technology Equipment (CISPR 22, modified), European Standard
Emission conducted, Frequency Range 150 kHz to 30 MHz.

Measurement of EMI Immunity

Conforming EN 50082-1, **European Standard**,
Electromagnetic Compatibility - Generic Immunity Standard
Generic Standard Class: Residential, Commercial, or Light Industry.
Additional 5017 specifications under EMC test conditions

ENV 50140

EMC Immunity against radiated EMI (Electromagnetic Interference).
EMC Basic Directive, 30-1000MHz. Residential environment
EMI Radiation: 3V/m, 80%AM - f.e. Handy in a distance of 3-5m
5017 Specifications min. +/- 0.1 % F. S. (Full Scale)

ENV 50141

EMC Immunity against conducted EMI
EMC Basic Directive, 150 kHz - 80 MHz
EMI Source: 3V_{RMS} on open wires.
5017 Specifications min. +/- 0.1% F.S.

EN 61000-4-2

ESD Immunity Part 4-2
ESD: Air or Contact Discharge +/-8kV / 4 kV - Protection Class 2.
5017 Specifications min. +/- 0.1% F.S.

EN 61000-4-4

Burst and electrical fast transient immunity Part 4-4
Environment: Industrial Area 2kVpk - Protection Class 3.
5017 Specifications min. +/- 0.1% F.S.

EN 61000-4-5

Surge Immunity Test, Part 4-5
Environment: Industrial Area 2kV non symm. - Protection Class 3.
5017 Specifications min. +/- 0.1% F.S.

9.14 General

SECURITY complies with EN 61010,
Ground is connected to the case.

WARM-UP TIME 20 min. to reach 1-Year Accuracy,
1h to reach 24h Stability.

ENVIRONMENT TEMPERATURE

Operation..... 10°C to 45°C
Storage..... -25°C to 60°C

RELATIVE HUMIDITY

Operation..... 20% to 75% (at 0°C to 25°C)
20% to 65% (at 25°C to 45°C)
Storage 10% to 90% (40°C)
Transportation..... 5% to 95% (40°C)
in each case excluding condensation

POWER SUPPLY

Voltage 230V (switchable to 115V)

115V +15%, -22%
Mains Fuse with 0.4A

230V +15%, -22%
Mains Fuse with 0.2A

Power typ. 20 VA /max. 50 VA
Frequency 47 to 63 Hz

WEIGHT about 3.4 kg, 7.5 lbs

CASE ½-19" Case 2 HU
Cast Aluminum Case

DIMENSIONS

Height about 96 mm / 3.8 inch with feet
about 89 mm / 3.5 inch without feet
Width about 225 mm / 8.86 inch
Depth about 375 mm / 14.7 inch

DIMENSIONS OF DELIVERED PACKAGE (CARTON)

Height about 270 mm / 10.6 inch
Width about 320 mm / 12.6 inch
Depth about 460 mm / 18.1 inch

10 Accessories

10.1 Adaptercard (3110)

The adaptercard can be connected externally to the 50-wire Sub-D connector on the rear of the 5017 when it is equipped with a scanner (5017SC). This card contains screw terminals for the incoming wires and so it is useful when you need to change the configurations of sources being scanned.

Two adaptercards are required for connecting all 80 channels.

Dimensions: approx.. 70 mm x 110 mm

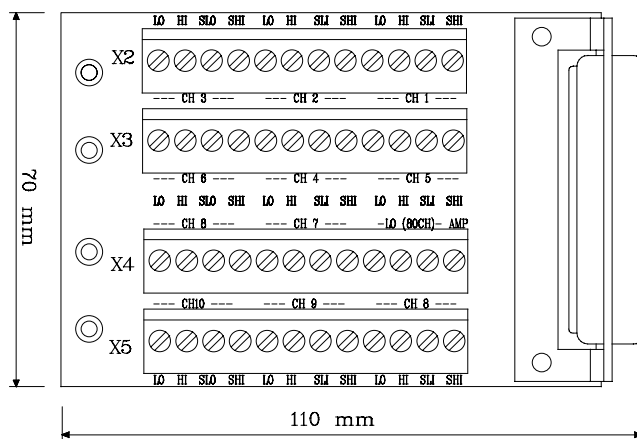

Figure: Adaptercard 3110 for scanner input

Warning: Voltages greater than 40V to ground should not be connected to the adaptercard because the screw terminals are not protected against human touch.

10.2 Mating Plug for Sub-D (6000/03)

A 50-wire subminiature type D connector can be used for each set of 10 channels (4-pole). This connector has solder connections for each wire and a cable outlet for round cables up to 12 mm diameter.

Two plugs are necessary for connecting all 80 channels.

10.3 Pt100 Temperature Probes (3011 and 3012)

Pt100-Temperature Probe in 4-wire connection with handle.

Connection to the DMM via a 1.5m cable with 4 gold plated banana plugs.

Model	Surface Probe 3011	Immersion Probe 3012
Sensor	Pt100 (Platinum RTD100)	Pt100 (Platinum RTD100)
Connection	4-wire	4-wire
Temp. Range (Sensor)	-50°C to 220°C	-50°C to 600°C
max. Temp. (Handle)	-25°C to about 80°C	-25°C to about 80°C
Accuracy (Sensor)	1/3 DIN B	1/3 DIN B
Probe Length	160mm without handle	160mm without handle
Diameter	Contact Surface: \varnothing 9mm	Pipe: \varnothing 5mm
Cable Length	1,5m	1,5m
Connectors	4 Banana Plugs, 4mm	4 Banana Plugs, 4mm

10.4 Test Lead Set (3014)

The Test Lead Set consists of two, 1m long cables with shrouded, 4mm banana plugs and two probe tips. The contacts of the plugs have low thermal voltages, which is necessary for precise measurements.

10.5 Set of Short Circuit Plugs (3016)

This set contains 3 gold plated short circuit plugs, which can be connected together. In this design it is possible to generate a very reliable short circuit for observing the zero point of the instrument. Three plugs can generate an excellent short circuit in 4-wire resistance measurement.

10.6 Current Shunt (3017)

Current Shunt up to 10A, Resolution 10mV/A; DC Accuracy: 0,1%

10.7 RS232 Cable (3018)

RS232 cable for controlling the 5017 from a PC with RS232 interface.
Zero Modem Cable with RTS/CTS and SD/RD lines crossed.

10.8 Carrying Case (4100)

Flexible carrying case for 5017 and accessories with handle and shoulder strap.

Dimensions in cm : about 27 x 39 x 15 (W x H x D)

10.9 Accessories for the IEEE488 Bus

An interface card in the PC is necessary to remote control the 5017. PREMA offers the following IEEE488 interface card for PC/AT/XT and compatibles:

- | | |
|-------|--|
| 5025 | IEEE-488 Interface Card PC2A for PC XT/AT
incl. Drivers for C, Basic, QuickBasic, VisualBasic.
More variations on request. |
| 5023K | IEEE-488 Interface Cable, shielded, Length: 2m. |

10.10 19-inch Rack Mounting Kit (5021 G)

Complete Slide-In module to mount a 5017 into a 19-inch rack.
Height 2 HU.

The rack mounting kit is delivered with all essential screws.
An extra shield is also delivered if there is only one 5017 in use.

Index

- *
 - *CLS Clear Status • 5-5
 - *ESE Event Status Enable • 5-6
 - *IDN? Identification • 5-7
 - *OPC Operation Completed • 5-7
 - *RST Reset • 5-7
 - *SRE Service Request Enable
 - Command • 5-8
 - *STB? Read Status Byte
 - Command • 5-8
 - *WAI Wait to Continue
 - Command • 5-9
- 1**
 - 19-inch Rack Mounting Kit • 10-4
- A**
 - AC Current
 - Calibration • 6-9
 - Specifications • 9-11
 - AC Voltage
 - Calibration • 6-9
 - Specifications • 9-7
 - Accessories • 10-1
 - Accuracy
 - AC Current • 9-11
 - AC Voltage • **9-7**
 - DC Current • 9-9
 - DC Voltage • 9-2
 - Frequency • 9-14
 - Period • 9-14
 - Resistance • 9-5
 - Temperature • 9-13
 - Adaptercard • 10-1
 - AD-Converter • 8-2
 - ADR
 - Display • 4-5
 - Ambient Temperature
 - for Calibration • 9-1
 - Analog Processor • 8-7
 - AUTO
 - Display • 4-4
 - Automated Calibration • 6-2
 - Automatic filter • 4-14
- B**
 - Baud Rate
 - RS232 Interface • **9-21**
 - Burden Voltage
 - AC Current • 9-11
 - DC Current • 9-10
 - Operating Instructions • 7-9
- C**
 - Calibration • 6-1
 - Calibration Equipment • 6-1
 - Calibration Periods • 6-1
 - Calibration Service • 6-1
 - Calibration Switch • 6-4
 - Calibrator • 6-1
 - Carrying Case • 10-3
 - Case for 8017 • 10-3
 - CE Marking • 9-24
 - Certificate of Calibration • 2-5
 - Channel selection • 4-8
 - Command Set • 4-19
 - Common Commands • 5-5
 - Common Mode Rejection
 - DC Voltage • 9-3
 - Common Mode Suppression DC
 - Voltage
 - Operating Instructions • 7-3
 - Compatibility
 - IEEE488 Interface • **9-19**
 - Remote control • 5-23
 - Configuration
 - IEEE4888 • 5-2
 - Remote control • 5-1
 - RS232 • 5-1
 - Configure
 - Menu • 4-13
 - Connecting
 - Measuring cables • 4-5
 - Connecting to Main Power • 2-3
 - Connection of Leads • 2-6
 - Connection to Rear Panel • 2-8
 - Connection to Scanner • 2-8
 - Connector Type
 - RS232 Interface • **9-21**
 - TTL I/O Interface • 9-23
 - Construction • 8-1
 - AC-Voltage • 8-5
 - Frequency • 8-5
 - Front-Rear Connectors • 8-9
 - Measurement Inputs • 8-9
 - Continuity • 3-7
 - Contrast setting • 4-17
 - Conversion Method
 - AC Current • 9-11
 - AC Voltage • 9-7
 - Crest Factor
 - AC Current • 9-12
 - AC Voltage • 9-8
- Current
 - Quickstart • 3-3
 - Current Shunt • 10-3
- D**
 - Damage during Transport • 2-1
 - Data Format
 - RS232 Interface • **9-21**
 - DC Current
 - Calibration • 6-9
 - Specifications • 9-9
 - DC Voltage
 - Calibration • 6-7
 - Specifications • 9-1
 - Default Settings • 3-1
 - Delay Time
 - Scanner • 9-16
 - Delivery • 2-1
 - Device
 - Menu • 4-17
 - Device address
 - Setting • 5-2
 - Digital I/O Port • 8-8
 - Dimensions of Case • 9-26
 - Diode Test • 3-7
 - Display • 8-8
 - Measuring function • 4-4
 - Display elements • 4-4
 - Display field • 4-4
 - Display formats • 4-21
 - Display mode • 5-14
 - Display Range
 - Temperature • 9-12
 - Dual assignment, keys • 4-1
- E**
 - EMC compliance test • 9-24
 - End detection
 - IEEE488 • 5-2
 - RS232 • 5-2
 - Environment Temperature • 9-26
 - EOI
 - Remote control • 5-2
 - EPROM software version • 5-7
 - Error messages • 4-24
 - Remote control • 5-21
 - EU conformity • 9-24
- F**
 - FILT
 - Display • 4-5
 - Filtering • 4-13

Frequency
 Quickstart • 3-6
 Specifications • 9-14
 Frequency Range
 Frequency • 9-14
 Front panel • 4-1
 Front Panel Controller • 8-7
 Front view • 4-1
 Full Scale
 DC Current • 9-9
 DC Voltage • 9-1
 Function field • 4-2
 Functions
 Calibration • 6-5

G

Getting Started • 2-1
 Grounding • 2-4

H

Handshake
 RS232 Interface • 9-21
 Handshake mode • 4-19; 5-1
 Humidity • 9-26

I

IEEE-488
 Common Commands • 5-5
 IEEE488
 Capabilities • 5-4
 Configuration • 5-2
 Multiwire messages • 5-4
 IEEE488 Accessories • 10-3
 IEEE488 interface
 Setting • 4-18
 IEEE488 Port • 8-8
 Input circuit • 8-1
 Input Resistance
 AC Voltage • 9-8
 DC Voltage • 9-2
 Input Resistance DC Voltage
 Operating Instructions • 7-1
 Input Signal
 Frequency • 9-14
 Period • 9-14
 Input Voltage
 TTL I/O Interface • 9-23
 Instrument setting
 Load • 4-15
 Save • 4-15
 Instrument Shunt
 DC Current • 9-10
 Integration Time
 Selection • 3-8
 Interface

Preselection • 4-18
 Interface select • 5-1
 Intergrating AD-Converter • 8-2
 Isolation
 Scanner • 9-16

K

Key functions • 4-2
 Keypad • 4-1

L

LCD display • 4-4
 Lead Resistance
 Scanner • 9-16
 LF,String Terminator • 5-2
 Life Time
 Scanner • 9-16
 Limiting data • 4-6
 Linearization
 Temperature • 9-13
 Listener • 5-11
 Loudspeaker
 Switch-on/off • 4-21

M

Main Processor • 8-6
 Mains Synchronization • 8-3
 Manual control
 Menu • 4-9
 MATH
 Display • 4-4
 Mathematical programs • 4-11
 Manual control • 4-11
 Meaning • 4-12
 Mating Plug Sub-D • 10-2
 Meas. Functions
 Scanner • 9-16
 Measurement Current
 Temperature • 9-12
 Measurement Leads • 10-2
 Measurement Method
 Frequency • 9-14
 Measurement Pauses
 AC Current • 9-12
 AC Voltage • 9-8
 DC Current • 9-10
 DC Voltage • 9-3
 Temperature • 9-13
 Measurement Times
 AC Current • 9-11
 AC Voltage • 9-7
 DC Current • 9-9
 DC Voltage • 9-1
 Resistance • 9-5
 Temperature • 9-13

Measuring Current
 Resistance • 9-6
 Measuring function
 Setting • 4-7
 Measuring inputs • 4-5
 Measuring Pauses
 Resistance • 9-6
 Measuring range
 Selection • 4-7
 Memory • 8-8
 Menu structure • 4-10
 Meßstellenumschalter
 Aufbau • 8-10
 Microprocessors • 8-6
 Moving average filter • 4-14
 Multifunction Calibrator • 6-3

N

Noise Effects
 Operating Instructions • 7-4
 Noise Suppression
 DC Voltage • 9-3

O

Offset correction • 4-8
 Calibration • 6-2; 6-6
 Offset Current
 DC Voltage • 9-2
 Operating Instructions • 7-1
 Current Measurement • 7-9
 DC Volt Measurement • 7-1
 Four-Wire Resistance • 7-7
 Resistance Measurement • 7-5
 Temperature Measurement • 7-10
 Two-Wire Resistance • 7-5
 Operation, manual • 4-1
 Original Packaging • 2-1
 Output Voltage
 TTL I/O Interface • 9-23
 Overload Limits
 AC Current • 9-12
 AC Voltage • 9-8
 DC Current • 9-10
 DC Voltage • 9-4
 Resistance • 9-6
 Scanner • 9-16
 Overview
 Menu • 4-10

P

Packaging Material • 2-1
 Period
 Quickstart • 3-6
 Specifications • 9-14

- PIN Assignments
 - IEEE488 Interface • 9-20
 - RS232 Interface • 9-21
 - Scanner • 9-17
 - TTL I/O Interface • 9-23
- PLL-Circuit • 8-3
- Polarity Change
 - DC Voltage • 9-3
- Ports • 8-8
- Power Dissipation
 - Operating Instructions • 7-8
- Power Filter • 8-9
- Power Management • 8-7
- Power Supply • 9-26
- Power-up status • 4-16
- Programming Language
 - IEEE488 Interface • **9-19**
- Pt100-Temperature Probe • 10-2

Q

- Quick Start • 3-1

R

- Rack Mounting Kit • 2-8; 10-4
- Range Selection • 3-7
 - Resistance • 9-5
- RANGE/Menu Field • 4-3
- Ranges
- Ranges
 - AC Current • 9-11
 - AC Voltage • 9-7
 - DC Current • 9-9
 - Period • 9-14
 - Resistance • 9-5
- Ranges to calibrate • 6-2
- Read Status Byte
 - Remote Control • 5-8
- REAR
 - Display • 4-4
- Rear Panel Connection • 2-6
- Reference • 8-4
- REM
 - Display • 4-5
- Remote control • 5-1
- Reset
 - SCPI • 5-7
- Resistance
 - Calibration • 6-8
 - Quickstart • 3-4
 - Specifications • 9-5
- Resistance Measurement
 - Operating Instructions • 7-5
- Resolution
 - AC Voltage • 9-7
 - DC Voltage • 9-1
 - Resistance • 9-5
- RMS Converter • 8-5

- RS232
 - Capabilities • 5-3
 - Configuration • 5-1
- RS232 Cable • 10-3
- RS232 interface setting • 4-18; 4-19
- RS232 Serial Interface • 9-21

S

- Safety Information • 2-2
- Safety Symbols • 2-3
- Sampling Converter
 - Calibration • 6-7
- Scanner Controller • 8-7
- Scanner mode
 - Setting • 4-23
- Secret Code • 6-4
- Self test query
 - SCPI • 5-9
- Sensor Configuration • 3-5
- Serial Port • 8-8
- Series Mode Rejection
 - DC Voltage • 9-3
- Series Mode Suppression DC Voltage
 - Operating Instructions • 7-2
- Service for Calibration • 6-1
- Service Request • 5-8
- Settling Time
 - AC Voltage • 9-8
- Short Circuit Plugs • 10-3
- Software version • 5-7
- Specifications • 9-1
 - AC Current • 9-11
 - AC Voltage • 9-7
 - DC Current • 9-9
 - Frequency • 9-14
 - General • 9-26
 - IEEE488 Interface • 9-19
 - Period • 9-14
 - Resistance • 9-5
 - RS232 Interface • 9-21
 - Scanner • 9-16
 - Temperature • 9-12
 - TTL I/O Interface • 9-23
- SRQ mode • 5-16
- Stability
 - DC Voltage • 9-1
 - Resistance • 9-5
 - Temperature • 9-13
- Start mode • 4-13
- STORE
 - Display • 4-5
- Storing Calibration Values • 6-11
- String length • 5-16
- Switching Method
 - Scanner • 9-16
- Switch-on Setting • 3-1

- Synchronization • 8-3

T

- Talker mode • 5-16
- Temperature
 - Quickstart • 3-5
 - Specifications • 9-12
- Temperature Coefficient
 - AC Current • 9-11
 - AC Voltage • 9-7
 - DC Current • 9-10
 - DC Voltage • 9-2
 - Resistance • 9-6
 - Temperature • 9-13
- Temperature Measurements
 - Operating Instructions • 7-10
- Temperature sensor
 - Selecting • 4-20
- Temperature Sensors
 - RTD Sensors • 9-12
- Temperature Unit • 3-5
- Terminator
 - IEEE488 Interface • **9-19**
- Test Leads • 10-2
- Thermal Voltages
 - Operating Instructions • 7-3
- Thermo Couples • 3-5
- Thermo Voltage
 - Scanner • 9-16
- Transmitted string • 5-18
 - Meaning • 5-19
- TRIG
 - Display • 4-4
- Trigger mode • 4-13
- TST? Self test
 - Command • 5-9
- TTL I/O Interface • 9-23
- Turning off • 2-5
- Turning on • 2-5

V

- Voltage
 - Quickstart • 3-2

W

- Wait command • 5-9
- Warm-up
 - Calibration • 6-3
- Warm-Up Time • 9-26
- Warranty • 2-5
- Weight • 9-26

Z

- Zero Point

Calibration • 6-6

DC Voltage • 9-2