

xDevs.com TEMP+RH Sensor
<https://xdevs.com/guide/xth/>

VCC can be +1.8V or +3.3V

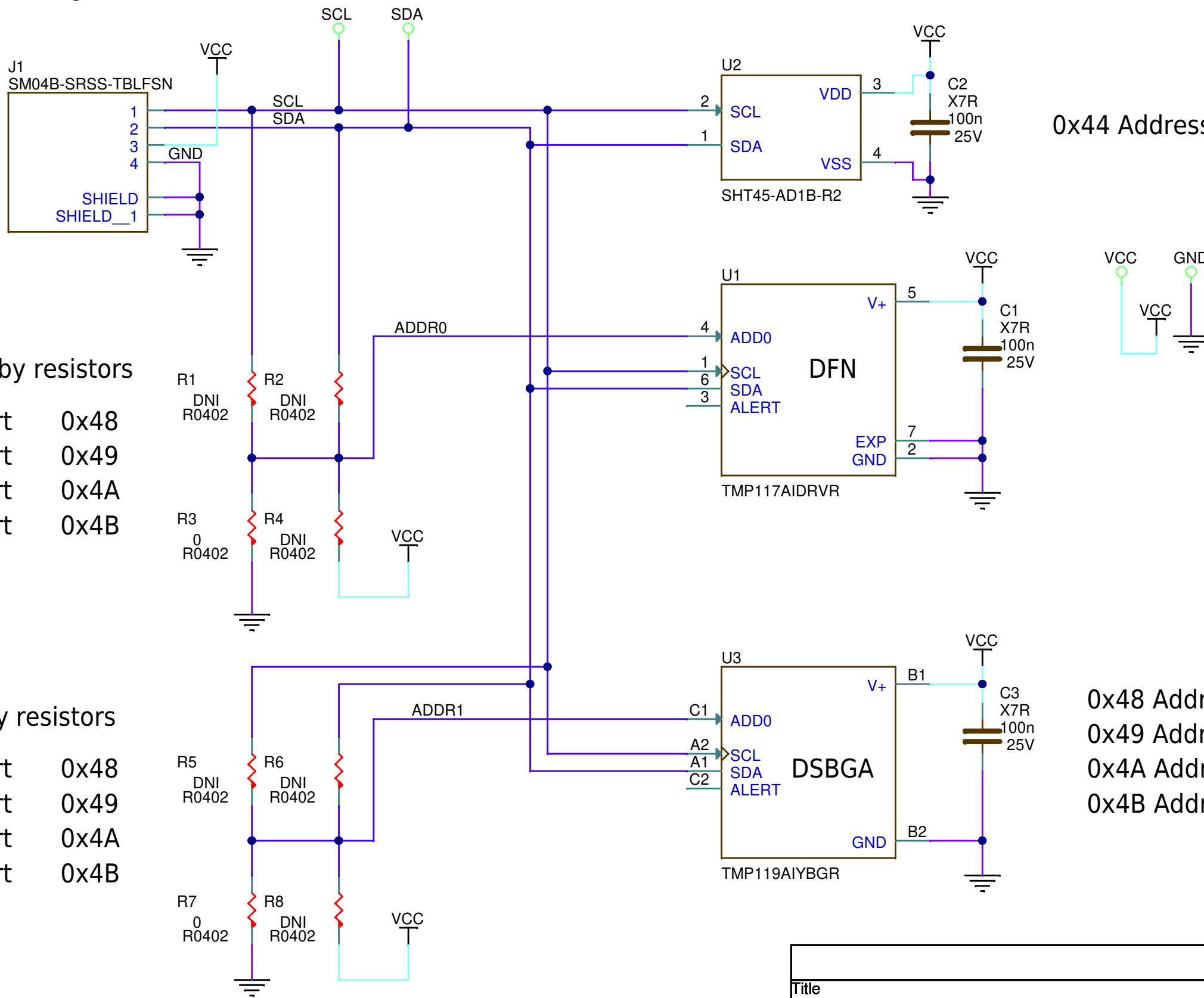

0x44 Address

0x48 Address
 0x49 Address
 0x4A Address
 0x4B Address

Set address by resistors

- R3 = short 0x48
- R4 = short 0x49
- R2 = short 0x4A
- R1 = short 0x4B

Set address by resistors

- R7 = short 0x48
- R8 = short 0x49
- R6 = short 0x4A
- R5 = short 0x4B

VCC can be +1.8V or +3.3V

Title		
XRE-100-000		
Size	Document Number	Rev
A	xDevs.com RDE	0.0
Date:	Thursday, March 07, 2024	Sheet 1 of 1