

1575A/1590 “Super-Thermometer” Thermometer Readouts

Technical Data



Fluke Corporation Hart Scientific Division’s Super-Thermometers are recognized in metrology laboratories around the world for their ease of use and reliable accuracy. The Model 1575A Super-Thermometer is accurate to 0.001°C or 4ppm. The Model 1590 Super-Thermometer II is accurate to 0.00025°C, or 1 ppm.

Both Super-Thermometers are perfectly suited for SPRT calibrations. These are the best lab instruments to take advantage of SPRT accuracy. They’re easy to use, they read temperature directly, they have automated data collection, they automatically calculate constants for ITS-90, and both of them are priced at less than half the price of the competitors’ resistance bridges.

Of course, there’s more.

Bridges

Resistance bridges are one of the most expensive pieces of lab equipment you can buy. Most sell for \$30,000 to \$50,000. The resistance bridge market is very small, and there’s hardly any competition. There’s nothing to control the price except your willingness to pay.

Resistance bridges are difficult to use. Their learning curve is long and complex, which means you’ll spend plenty of time learning to master one. Time spent learning costs you money,

and costs multiply if you have to train other people!

So why buy a bridge if you have a legitimate alternative?

If 1 ppm accuracy gets the job done, the easiest and cheapest way to do it is with one of Hart’s Super-Thermometers.

1575A

The 1575A Super-Thermometer is a best-selling thermometer readout because of its ease of use, high accuracy, built-in software, and reasonable price. Temperature is read directly on the display in your choice of scales. There are no manual resistance-to-temperature conversions. Resistance is converted to temperature for you using the ITS-90 algorithm in any one of the instrument’s ranges. Up to 16 independent sets of probe characterizations can be stored in the 1575A’s memory. Switch SPRTs and simply call up its reference identification number. Forget the extensive, time-consuming setup required by resistance bridges. Read the features common to both units and you’ll understand why each is a great buy.

1590

The 1590 Super-Thermometer II has all of the features of the 1575A, plus it has the unbeatable accuracy of 1 ppm and a color screen that tilts to create

- Accuracy to 4 ppm (0.001°C) or 1 ppm (0.00025°C)
- Bridge-level performance at less than half the cost
- Accepts 0.25-ohm through 100-ohm SPRTs plus thermistors
- Includes all temperature functions and stores setups

the best viewing angles. With all of these features, it’s still less than half the price of a bridge.

In many labs with standards that require the use of bridges, Super-Thermometers have been accepted as an alternative to bridges because they are a combination of bridge technology and microprocessor-based solid-state electronics—and they’re much easier to use.

Both Hart Super-Thermometers come with an accredited calibration.

Accuracy

The typical benchtop thermometer has an error level 5 to 10 times larger than the Super-Thermometer, and 20 to 40 times higher than a Super-Thermometer II. With common 25- or 100-ohm SPRTs, the 1575A Super-Thermometer achieves $\pm 0.002^\circ\text{C}$ accuracy and $\pm 0.001^\circ\text{C}$ accuracy with a calibrated external standard resistor. The 1590

Super-Thermometer II is even better with $\pm 0.00025^{\circ}\text{C}$ accuracy.

ITS-90 specifies the use of 2.5-ohm and 0.25-ohm SPRTs as high-temperature standards up to the silver point (962°C). This very small resistance is difficult to measure and is commonly done only with resistance bridges. The Super-Thermometers address ITS-90 problems directly and are absolutely the most cost-effective solution available.

In addition, resolution with a 25-ohm SPRT is 0.0001°C . Comparison calibrations or calibrations against primary standard fixed points are easily performed. Both instruments have two channels for handling two probes at once. Display and record actual temperatures or choose to read the difference between the two directly from the screen.

Both Super-Thermometers have their own on-board resistors. Each is a high-stability, low thermal coefficient, four-terminal resistor for each of the resistance ranges of the thermometer: 0.25 ohms, 2.5 ohms, 10 ohms, 25 ohms, 100 ohms, and thermistor ranges. Resistors are housed in an internal temperature-controlled oven. Can it get any better?

Well, actually it does.

DWF Connectors

Hart's patented Model 2392 DWF Connector is unique in the industry (U.S. Patent 5,964,625). Each one is machined from solid brass and then plated with gold. DWF Connectors ac-



Hart's patented DWF Connectors—so easy to use you'll never want to use anything else.

cept banana plugs, spade connectors, or bare wires. Banana plugs are inserted in the top. Bare wires go in one of the four side holes and are held in place by a spring-loaded pressure plate. Spade connectors are inserted between the top of the connector and pressure plate and are held in place the same as bare wire. The connec-

tions are solid and difficult to dislodge. Bare wire and spade connectors require nothing more than pushing the DWF Connector in. There's nothing to screw down or tighten.

Other Features

Super-Thermometers convert resistance to temperature using your choice of ITS-90 or IPTS-68. ITS-90 requires no conversions; just enter your coefficients directly. For IPTS-68 enter R0, ALPHA, DELTA, A4, and C4. Temperature can be converted from IPTS-68 to ITS-90 automatically at your request. Calendar-Van Dusen equations are also provided in an automated mode.

Thermistor probes are characterized by coefficients of a logarithmic polynomial. Save money and use low-cost, rugged thermistor standards for $\pm 0.001^{\circ}\text{C}$ accuracy in the low-temperature regions. Other thermometers don't do all this.

Measurements can be displayed as temperatures in $^{\circ}\text{C}$, K, or $^{\circ}\text{F}$ and as resistance in ohms or a ratio of probe resistance to reference resistance. The current source is controllable between 0.001 mA and 15 mA with a resolution of 0.2%. Integration time and digital filtering are programmable to optimize resolution, stability, and response.

Datalogging and memory functions store measurements, and each thermometer has its own 3.5-inch disc drive for archiving data. The display is a backlit LCD for visual display of information. It has an RS-232, an IEEE-488, and a parallel printer port.

These Super-Thermometers are based on DC electronics, thus eliminating the problems with national lab certification for AC bridges and the removal of quadrature interference from AC-heated fixed-point furnaces. Read about the complete Theory of Operation of Hart Super-Thermometers at www.hartscientific.com

Multiplexers

If two channels aren't enough, add 10 more with a Mighty-Mux featuring Hart's handy DWF connectors. In fact, add up to 50 more channels to the 1590.

The Model 2575 provides 10 more channels for use with a 1575. For the 1590, the Model 2590 Mighty-Mux II has a cascading ability that lets you have up to 50 channels by chaining more than one Mux together, and you can now set continuous constant current levels on each channel to avoid



Add 10 channels to a 1575A Super-Thermometer with a 2575 Mighty-Mux. Or add up to 50 channels to a 1590 Super Thermometer II with 10-channel 2590 Mighty-Mux II multiplexers.

self-heating effects. Whatever your application, a Mighty-Mux will make it easier and more efficient.

Both units have low thermal EMF relays that are hermetically sealed and magnetically shielded. You're making true four-wire measurements with a floating guard and support for up to 20 mA of drive current.

Super-Thermometers vs. Digital Multimeters

Good eight-and-a-half-digit multimeters might give you accuracy to $\pm 0.005^{\circ}\text{C}$ in the resistance measurement. However, DMMs require separate high-stability current sources, and you have to make EMF offsets, worry about a scheme to switch between forward and reverse current during the measurement, and devise a switch to get a second channel for an external standard resistor.

Once you've done all of this, you still have to convert resistance to temperature with tedious manual calculations.

Super-Thermometers do all of this automatically.

Super-Thermometers vs. Everything Else

There really isn't anything else to compare to the 1590 and 1575A. No other readout is this easy to use. You'll be doing calibrations with it the first day you receive it, not the first day after the training program is over.

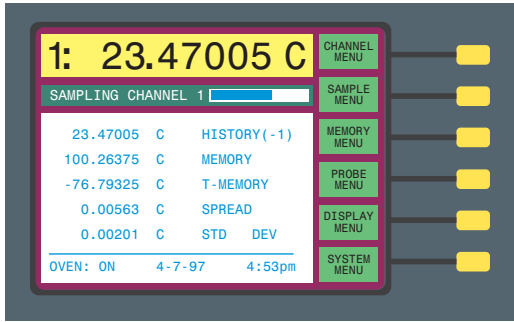

Customize Your Display

The graphic screen is easily modified to include information that fits your application or preferences. Under the display menu you select up to five lines of on-screen information from 19 different options including:

T - MEMORY	Current value minus the value in memory
T (1) - T (2)	Channel one minus channel two
MAXIMUM	Peak reading since last reset
MINIMUM	Lowest value since last reset
SPREAD	Maximum difference between readings
AVERAGE	Computes average of previous samples
STD DEV	Computes standard deviation of previous samples

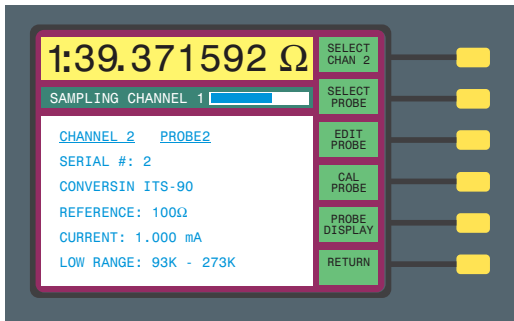

Probe Setup

Each probe's information is identified by its unique serial number for assignment to a specific channel. You select the desired resistance-to-temperature conversion formula, set the probe constants, and select the reference resistor and the drive current. A total of 16 probe setups are stored in internal memory. An unlimited number can be stored to disk and selected when needed. After a probe's information is entered the first time, the Super-Thermometer is immediately set to match that probe by simply selecting the probe's serial number.

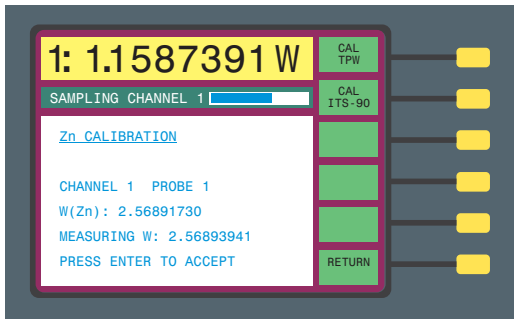

Automatic Calculation of Constants

The Super-Thermometers automatically calculate the required constants for the ITS-90 temperature conversion. Connect your uncalibrated standards probe to the 1590, measure the resistance at the fixed-points or against a calibrated standard, and the 1590 stores the resistance readings and automatically derives the correct constants. You don't need a calculator and a pad of paper. The Super-Thermometers enter the constants directly to the probe setup, saving you time and preventing error in the manual entry of constants.

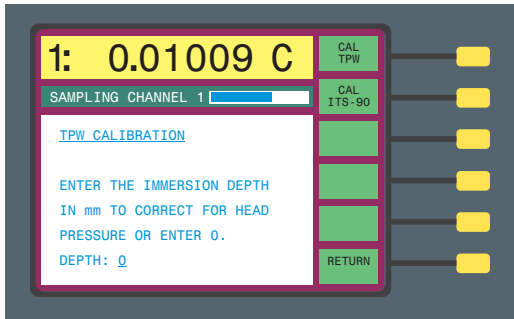

The Triple Point of Water

Take a reading in the TPW cell just prior to each new measurement. The Super-Thermometers store the current RTPW value and reference it during the conversion from resistance to temperature. This eliminates two sources of measurement error. The drift of RTPW in the SPRT is removed, and the error of the on-board reference resistors is canceled. For convenience and maximum precision, you can even enter the immersion depth of your SPRT in the cell to correct for hydrostatic head.

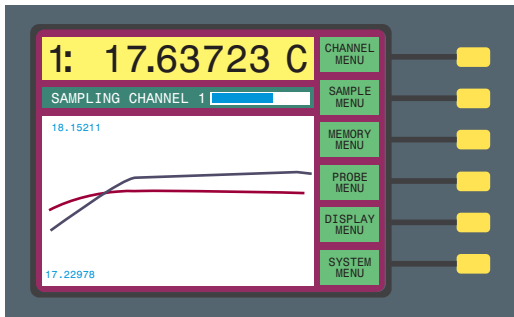

Graphing Feature

The Super-Thermometers feature real-time, on-scale graphing for monitoring fluid bath stabilization or realizing metal fixed-point plateaus. Simply monitor the graph for stability on one or multiple channels and take your readings in resistance, temperature, or the ratio to the triple point of water. The 3.5-inch disc drive stores readings in an ASCII format for spreadsheet or graphing use. Graphing resolution limits can be manually entered, or maximum resolution is automatically set as the readings stabilize over time. Temperature measurement labs save time by not monitoring or taking data every few seconds.

Specifications

	1575A			1590		
	Nominal Resistance	Accuracy (of indicated value)	Equivalent Temp. Value, at 0°C	Nominal Resistance	Accuracy (of indicated value)	Equivalent Temp. Value, at 0°C
Transfer Accuracy (using external reference resistor)	0.25Ω	40 ppm	0.01°C	0.25Ω	20 ppm	0.005°C
	2.5Ω	20 ppm	0.005°C	2.5Ω	5 ppm	0.00125°C
	25Ω	4 ppm	0.001°C	25Ω	1 ppm	0.00025°C
	100Ω	4 ppm	0.001°C	100Ω	1 ppm	0.00025°C
	10 KΩ	10 ppm	0.00025°C (thermistor at 25°C)	10 KΩ	5 ppm	0.000125°C (thermistor at 25°C)
Absolute Accuracy (using internal reference resistor)	0.25Ω	100 ppm	0.025°C	0.25Ω	40 ppm	0.01°C
	2.5Ω	40 ppm	0.01°C	2.5Ω	20 ppm	0.005°C
	25Ω	8 ppm	0.002°C	25Ω	6 ppm	0.0015°C
	100Ω	8 ppm	0.002°C	100Ω	6 ppm	0.0015°C
	10 KΩ	20 ppm	0.0005°C (thermistor at 25°C)	10 KΩ	10 ppm	0.00025°C (thermistor at 25°C)
Typical Resolution	0.25Ω	10 ppm	0.0025°C	0.25Ω	10 ppm	0.0025°C
	2.5Ω	5 ppm	0.00125°C	2.5Ω	2 ppm	0.0005°C
	25Ω	1 ppm	0.00025°C	25Ω	0.5 ppm	0.000125°C
	100Ω	1 ppm	0.00025°C	100Ω	0.5 ppm	0.000125°C
	10 KΩ	3 ppm	0.000075°C (thermistor at 25°C)	10 KΩ	2 ppm	0.00005°C (thermistor at 25°C)
Resistance Range	0Ω to 500 KΩ					
Internal Reference Resistors	1Ω, 10Ω, 100Ω, 10 KΩ					
Minimum Measurement Period	2 seconds					
Current Source	0.001 mA to 15 mA, programmable					
Analog Output	-5 to +5 V					
Display	Monochrome LCD with CCFT backlight			Color LCD with CCFT backlight		
Power	100–125/200–250 V AC (user switchable), 50/60 Hz, 1 A					
Calibration	Includes NIST-traceable accredited calibration					

Specifications - Muxes	
Channels	2575: 10 2590: 10 per unit, cascade up to 5 units for 50 channels
Connector	4-wire plug, floating guard
Terminals	Gold-plated Hart DWF Connectors
Relays	Low thermal EMF, hermetically sealed, magnetically shielded
Contact Resistance	< 0.1Ω
Isolation	1 x 10 ¹² between relay legs
Channel Selection	Manual or auto
Current Capability	20 mA
Current Levels	1575A: Current on active channel only 1590: Standby current 1 mA, 0.5 mA, or 10 μA on all channels
Power	Via connection to 1575A or 1590
Size	20.3" W x 12.6" D x 7" H (516 x 320 x 178 mm)

Ordering Information

1575A	Super-Thermometer
2575	Multiplexer, 1575
1590	Super-Thermometer II
2590	Multiplexer, 1590
742A-25	Standard DC Resistor, 25Ω
742A-100	Standard DC Resistor, 100Ω

Super-Thermometer: Theory of Operation

Hart's "Super-Thermometer" readouts (Models 1575A and 1590) require a unique electronic design to achieve the necessary accuracy while meeting size, weight, cost, and speed constraints. This article explains the measurement technique used by these instruments and discusses issues related to performance.

Measurement Technique

Fundamentally, Super-Thermometers measure the resistance ratio between two resistors by comparing their voltages when equal currents are applied. The simplified schematic in Figure 1 shows the basic components of the measurement circuitry. The reference resistor and sensor are connected in series, and the current flows through both simultaneously. The current produces a voltage on each that is proportional to their respective resistances. The voltages are measured with the amplifier and ADC. Since only one of the voltages can be measured at a time, the relay must be used to switch between them.

The voltage on each resistor is measured twice: once with the current in one direction, and again with the current in the opposite direction. Subtracting the two voltage measurements eliminates offset voltages (including those arising from thermoelectric EMF) since these offsets are constant. In summary, one ratio measurement requires four voltage samples:

1. Sensor, forward current (V_{X1})
2. Sensor, reverse current (V_{X2})
3. Reference, forward current (V_{R1})
4. Reference, reverse current (V_{R2})

The voltage samples are subtracted and divided to produce a ratio of sensor resistance to reference resistance:

$$r = \frac{V_{X1} - V_{X2}}{V_{R1} - V_{R2}} = \frac{R_X}{R_R}$$

Using this approach, errors from driving current imprecision, voltage offsets, and amplifier and ADC inaccuracies are avoided because these all affect the voltage samples equally.

Each voltage sample requires 0.5 seconds. (It takes 0.15 seconds to set the current and relay and allow time for the voltages to settle and 0.35

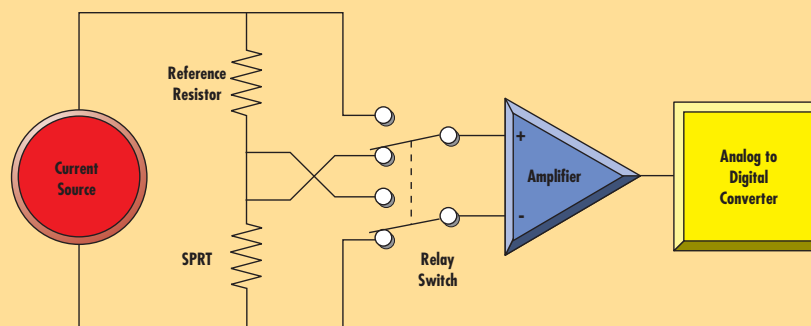

Figure 1. Simplified schematic diagram of the measurement circuit.

seconds for the ADC to make a measurement and send it to the CPU.) Since four samples are required, the entire ratio measurement takes two seconds.

Depending on how the measurement timing is set up, more than one raw ratio sample may be integrated into one measurement. Digital filtering is applied to reduce noise in the measurements. The CPU then calculates the resistance of the sensor by multiplying the measured resistance ratio by the known resistance of the reference resistor. Temperature is calculated from resistance using one of the built-in conversion algorithms. Finally, statistical values are recalculated to incorporate the latest measurement. Figure 2 shows this sequence of operations.

Performance Issues

Measurement of temperature with uncertainty approaching 1 mK or better presents some significant challenges. Various sources of error inherent in resistance thermometry make it difficult to achieve this level of accuracy. For instance, lead resistance in some cases can cause errors of several tenths of a degree. Problems also arise from sources such as thermoelectric EMF, reactance, and leakage. The accuracy achieved by the Super-Thermometers is only possible because these effects have been carefully studied and dealt with. Consider the following issues:

Lead Resistance

Measurements using an electrical sensor can be affected by the resis-

tance in the connecting wires, or leads. Resistance also exists in the connectors and the junctions between the wires and connectors. In commonly used two- or three-wire measurement circuits, these resistances and their variability cause errors from 0.1°C to 1.0°C.

Super-Thermometers use a four-wire circuit that completely eliminates the effects of lead resistance. In this scheme, often referred to as a Kelvin circuit, the sensor is driven with current from one set of wires and the resulting EMF is sensed with a different set of wires. The signal is passed to an amplifier with a very high input impedance that draws negligible current from the sensor. As a result, no measurable voltage develops along the EMF sensing wires. Super-Thermometers accurately measure the resistance of sensors even in the presence of lead resistance that can be as high as 10W.

Thermoelectric EMF

A resistance sensor such as a PRT contains several junctions between wires of different metals. These act like thermocouples generating small voltages called thermoelectric EMFs. Unless rejected in some way, these thermoelectric EMFs can interfere with the sensor EMF and degrade the accuracy of the measurement. There are three different techniques that can be used to cancel thermoelectric EMF.

Some resistance bridges apply AC driving current and use sensing circuits that detect only the AC signal, rejecting the DC EMFs. This technique

is very effective at eliminating thermoelectric EMF errors but can lead to other errors. Reactance, leakage, and eddy currents become much more significant with AC current. A different technique, sometimes used in DMMs, periodically switches off current to the sensor and measures the thermoelectric EMF directly. The problem with this is it leads to self-heating errors as the sensor warms and cools from the varying current.

Super-Thermometers use a third technique. Two separate measurements are made and the driving current is simply reversed for the second measurement. Thermoelectric EMF causes errors that are opposite in the two measurements. In essence, averaging the two measurements cancels the errors. This technique is very effective at eliminating errors from thermoelectric EMF while avoiding the AC-related errors and self-heating problems of the other methods. In fact, it's so effective that no observable error caused by thermoelectric EMF is found in the Super-Thermometers.

Reactance

The use of AC driving current often causes errors in resistance thermometry because sensors and their lead wires have inductance and capacitance that cannot be entirely eliminated. To get accurate temperature measurements, AC instruments must be used with sensors and wiring that have limited inductance and capacitance. They must also use quadrature balancing techniques to cancel the reactance as much as possible.

Super-Thermometers use DC circuitry that makes all of this unnecessary. Virtually any type of sensor may be used with a Super-Thermometer, even if the sensor has very large amounts of capacitance and inductance. Super-Thermometers allow plenty of time for currents and voltages to settle before beginning a sample. If necessary, the delay time can be increased even more.

Leakage

Resistance sensors can be susceptible to electrical leakage through the insulation material surrounding the lead wires and sensing element. Leakage is often significant at low temperatures where the insulation absorbs moisture from the air or at high temperatures where the electrical con-

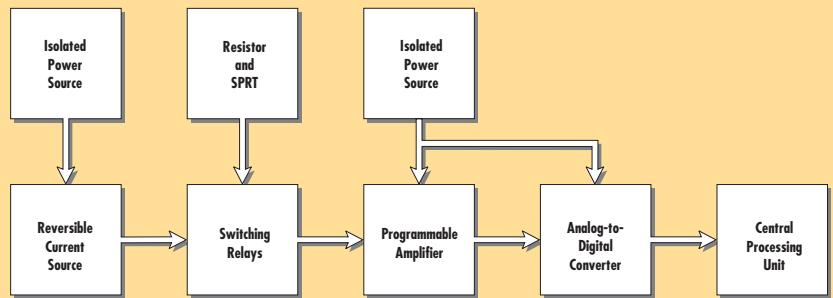

Figure 2. Measurement processing operations.

ductivity of the insulating material is relatively high. Leakage and some other effects, such as dielectric absorption and eddy currents, are much more significant with AC than with DC. By operating with DC driving current, Super-Thermometers achieve excellent accuracy over a wide range of conditions.

Self-Heating

"Self-heating" results from power being dissipated in the sensor by the driving current. It causes the temperature of the sensor to be higher than it should be. Super-Thermometers achieve full accuracy with small currents that minimize self-heating (1 mA for PRTs and 10 μ A for thermistors). The current can be set within a wide range and with excellent resolution. Being able to set the current to precise values allows self-heating errors to be controlled, measured, and eliminated.

Component Drift

The accuracy of a typical resistance measuring instrument is seriously limited by the stability, or lack thereof, of its electrical components. The design of the Super-Thermometers eliminates sensitivity to variations in the components due to aging or temperature by, in effect, recalibrating itself during every measurement. Drift of the driving current, amplifier bias current, amplifier offset voltage, amplifier gain, ADC offset, and ADC scale have no effect on the measurement.

The accuracy to which Super-Thermometers measure resistance is affected by the drift of only one component: the reference resistor. The four built-in resistors are high-quality, hermetically sealed, low temperature coefficient, metal film resistors that are temperature controlled for excellent stability. Even better stability can be achieved if external standard resis-

tors are used and they are immersed in a precisely controlled oil bath.

Noise and Resolution

Electrical noise is present in any measurement circuit—it's unavoidable. Excessive noise appears in measurements as random variations over time. This makes it impossible to detect small real changes in the parameter being measured. In other words, it limits the effective resolution of the measuring instrument.

Electrical noise in the Super-Thermometers comes from a variety of sources. A small amount of noise is generated by the resistors and semiconductor devices in the measurement circuitry. Some noise (quantization noise) results from the limited resolution of the ADC. Electrical interference or EMI from internal or external sources can also introduce noise. Although it is impossible to completely eliminate all noise, some steps can be and are taken to reduce it.

Components were selected for the Super-Thermometers that produce minimal noise. The ADC was chosen, in part, for its excellent resolution (24 bits). Shielding is used to block EMI from reaching the sensitive circuits. To further reduce noise, the Super-Thermometers use filtering and EMI suppression devices throughout the circuit. (Since DC driving current is used, interference coming from the 50/60 Hz mains supply is effectively rejected. AC instruments are more susceptible to this interference.) Finally, the CPU applies digital filtering to remove much of the remaining noise. The end result is the capability of making measurements with effective resolution of 0.25 ppm.

One possible drawback of digital filtering is that it makes the instrument react more slowly to changes in the

resistance or temperature being measured. Super-Thermometers allow the user to adjust the digital filter to achieve the right balance between resolution and response.

Nonlinearity

With all other sources of error under control, all that's left is nonlinearity. Consider nonlinearity to be curvature in the graph of the relationship between the actual resistance ratio and the resistance ratio measured by the Super-Thermometers. It is a result of imperfections in the analog-to-digital converter and also, to a smaller degree, the power supply and amplifier.

To minimize nonlinearity in the Super-Thermometers, three steps have been taken. First, the best available components have been selected. For instance, the ADC is a dual-slope integrating type that has linearity at least 10 times better than other precision integrating or sigma-delta ADCs.

Second, the employed measurement technique inherently rejects much of the nonlinearity. Because samples of opposite polarity are subtracted, zeroth-order errors (offsets), second-order errors, and all higher even-order components of nonlinearity are canceled. What's left are third-order and higher odd-order components that diminish greatly in magnitude the higher the order.

The third step is to mathematically correct for the third-order nonlinearity. This is the purpose of the "ADC" calibration parameter. This parameter is adjusted during calibration to achieve the best possible linearity.

Measurement Speed

The measurement technique used by the Super-Thermometers gives these instruments valuable attributes that others in its class don't have. One of these is speed. Super-Thermometers are capable of completing a new measurement in about two seconds. Even if multiple sensors are being measured in turn, the measurement time per sensor is still only two seconds. Compare this to a typical resistance bridge that takes 30 to 60 seconds to make the first measurement after a sensor is connected.

The speed of the Super-Thermometers gives it the advantage of allowing greater efficiency as well as better accuracy during a batch calibration pro-

cess involving a large number of sensors. Integrating a Super-Thermometer with its multiplexer (Model 2575 or 2590) enhances its capability even more, giving it 10 input channels (or up to 50 for the 1590). The measurement speed of the Super-Thermometers makes other applications possible such as tracking fast-changing temperatures, measuring temperature differences, or evaluating thermal response times.

Solid-State Design

Other advantages result from the solid-state approach used by the Super-Thermometers. Unlike a bridge that requires a large, heavy precision ratio transformer and dozens of relays, this instrument uses semiconductor circuits. This gives it better reliability, smaller size, lighter weight, and lower cost. By keeping the size and cost of the measuring circuit small, more resources can be dedicated to other important features such as intelligent user interface and system control electronics, a graphic display, and a built-in disk drive, all contributing to making Super-Thermometers the versatile, useful tools so many metrologists have come to rely on.

Fluke Corporation
Hart Scientific Division
799 E Utah Valley Drive
American Fork, UT 84003
Tel: 801.763.1600
Fax: 801.763.1010
E-mail: info@hartscientific.com

For more information call:
Europe/Africa/Middle East:
Fluke Europe B.V.
Hart Scientific Division
P.O. Box 1186, 5602 BD
Eindhoven, The Netherlands
Tel: (31 40) 2 675 200
Fax: (31 40) 2 675 222
Canada
Tel: 1-800-36-FLUKE or
905.890.7600
Fax: 905.890.6866
Other countries
Tel: 801.763.1600
Fax: 801.763.1010

Web access: www.hartscientific.com

© 2006 Fluke Corporation, Hart Scientific Division.
All rights reserved. Specifications subject to change
without notice. Printed in U.S.A. 3/2006
2646478 D-EN-N Rev A