

# Continuous time stamping

## Introduction

Most engineers have a deep-rooted notion of what a frequency counter is and what it does; a box having a numeric display with many digits, counting cycles per second, and only used for calibrating oscillators. This was perhaps true ten years ago, but is totally wrong today. Today's products can do much more, above all when it comes to characterizing dynamic signals with frequencies that change over time.

Modern frequency counters (for example the CNT-90 from Pendulum Instruments AB) have new measuring principles with sophisticated analysis, extremely improved resolution and sample speed, and a graphical display that shows jitter and modulation.

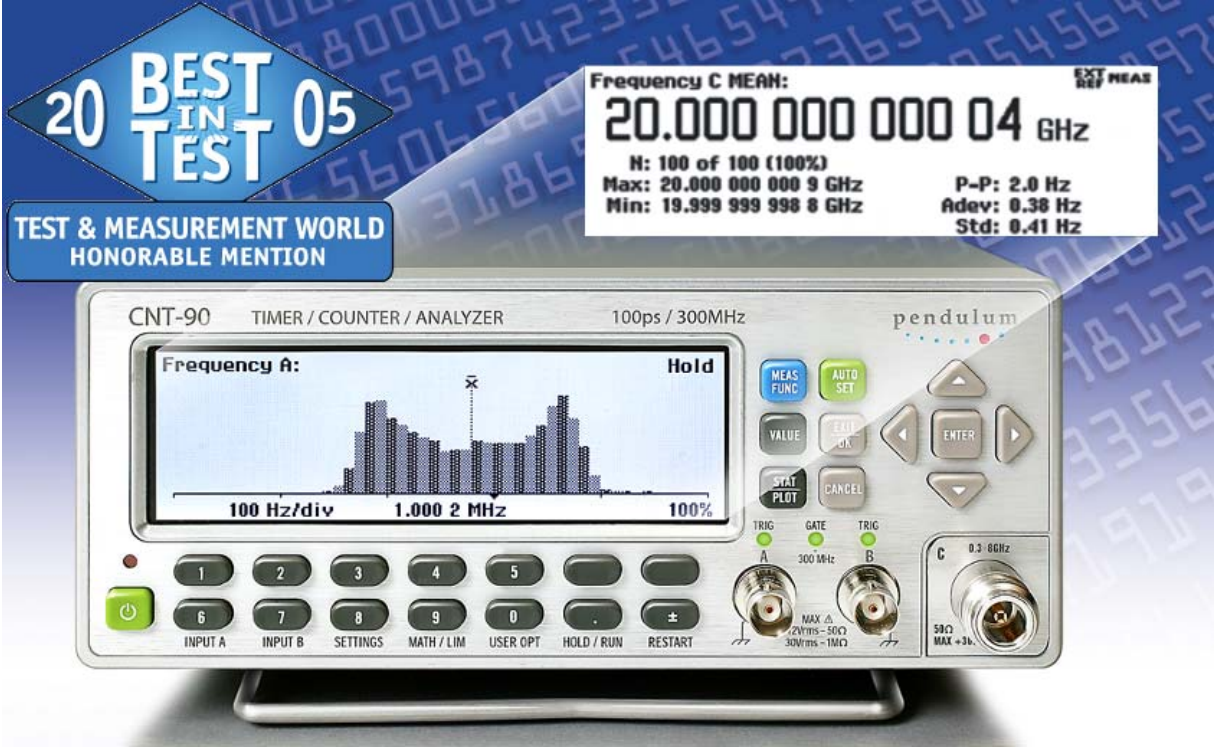

CNT-90 has a graphical display that shows jitter and modulation

Not only different forms of life follow Darwin's theory of evolution, but also frequency counters. Development has been evolutionary since the first products were introduced on the market about half a century ago. One of the most important parameters for a frequency counter is the resolution, so let us look at that:

Evolution	Time	Type	Resolution for 1s measuring time
Generation 1	1970	Conventional counters	2-8 digits
Generation 2	1980	Reciprocal counters	7-9 digits

Generation 3	1990	Interpolating reciprocal counters	9-11 digits
Generation 4	2000	Continuously time stamping counters with regression analysis *	12 digits

\* continuous time stamping was applied for the first time in Modulation Domain Analyzers from Hewlett-Packard at the end of the 1980s, however without resolution improvement.

The latest time and frequency measuring analyzer from Pendulum Instruments, the CNT-90, is the first product in the world in generation 4. Here you will get information on how sophisticated hardware and integrated statistical processes improve the resolution of frequency measurements with 1-2 digits compared to old methods.

## The reciprocal frequency counter

Conventional frequency counters are (almost) history today and deserve no text space.

Nowadays the most common measuring principle for frequency counters is reciprocal counting, which is based on measuring the time (clock pulses) between two identical trigger points (trigger level and trigger slope) on the input signal. Between these start and stop trigger events you count the number of signal cycles ( $N$ ) and at the same time the number of clock pulses from the built-in time base oscillator, occurring during the time  $T_N$ . Then the built-in processor calculates the frequency according to the definition " $N/T_N$ " or the period time according to the definition " $T_N/N$ ". See picture 2.

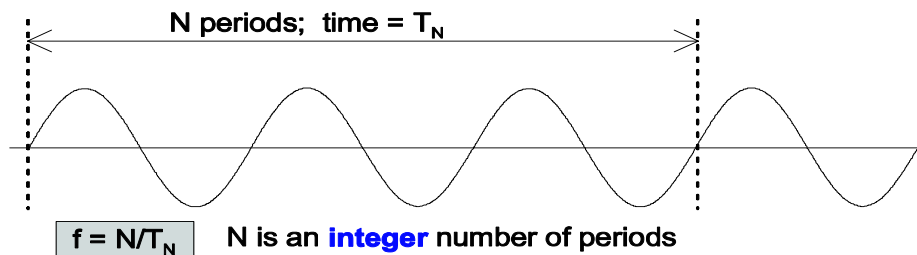

PICTURE 2. Frequency definition

Let us comment on the concept "reciprocal counting". In principle, the instrument measures a multiple period time  $T_N$  (over exactly  $N$  cycles) that is converted to frequency by the microprocessor. The frequency is of course the *reciprocal* value of the period time ( $f = T^{-1}$ ).

## Resolution in reciprocal counters

$N$  is an (exact) integer without uncertainty, since the measurement (start/stop of both counting chains) is synchronized with the input signal (and not with the clock pulses). See picture 3. But the measurement is instead totally unsynchronized with the clock pulses. We can therefore have parts of clock pulse periods that sometimes are counted and sometimes are not.

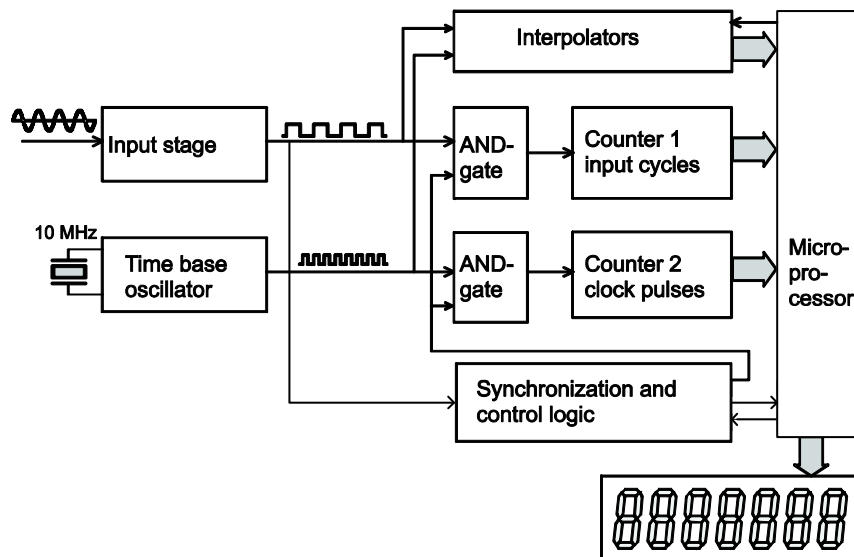

PICTURE 3 Block diagram for an interpolating reciprocal counter

The resolution in the time measurement  $T_N$  for a classic reciprocal counter is therefore 1 clock pulse period. Most counters have a 10 MHz time base oscillator, with the period time 100 ns, which gives us a relative resolution (absolute resolution/measuring time) of 7 digits in a measuring time of one second ( $100\text{ns}/1\text{s}=10^{-7}$ ), irrespective of the input signal frequency.

### Improved resolution

The resolution in classic reciprocal counters can be improved from 7 digits per second, in various ways.

- **Increased clock frequency.** By multiplying the time base oscillator's clock frequency from 10 MHz to t 100 MHz, thus 10 ns period time, the resolution is also improved. During a measuring time of 1 s the resolution will be 8 digits ( $10\text{ ns}/1\text{ s}=10^{-8}$ ),
- By interpolation to 9-10 figures
- By a combination of the above

### The interpolating frequency counter

In the interpolating frequency counter, you start from the reciprocal counter with its time measurement uncertainty of 1 clock cycle. This is due to the fact that you don't know where in the clock pulse cycle the measurement starts and stops. With a special interpolation circuit, you can determine the phase angle of the clock pulse at the start and stop of the measurement. You have always two identical interpolators in operation at the same time, one for the start and one for the stop. Such an interpolator can be built in various ways. A common implementation is the analogue interpolator, where the time difference between trigger event and clock signal is converted to an analogue voltage that can be measured with a common ADC.

In theory, the resolution for time measurements is improved from the 100 ns of "digital clock pulse counting" to:

$$1 \text{ clock pulse period}/\text{interpolation factor for interpolator counting.}$$

In practice it can be difficult to achieve that precision, since there exist several sources of errors that need to be held under strict control, e.g. interpolator linearity.

The interpolation factor usually stays between 100 and 500 times. With a clock frequency of 10 MHz the typical time resolution will be 200 ps to 1 ns (compared with 100 ns), which gives 9-10 digits for 1 s measuring time.

In Pendulum's Model CNT-81 we have combined interpolation with a 100 MHz clock oscillator, and reach 50 ps time resolution and 11 digits resolution for 1 s measuring time.

## Continuous time stamping

In a reciprocal frequency counter, with or without interpolation, the frequency measurement has a defined start (start trigger event) and a defined stop (stop trigger event). Between each start and stop measurement there is an unavoidable dead time for outputting the results, resetting the registers, and preparing the next measurement.

However, this scenario does not apply to continuously time stamping counters. See picture xx.

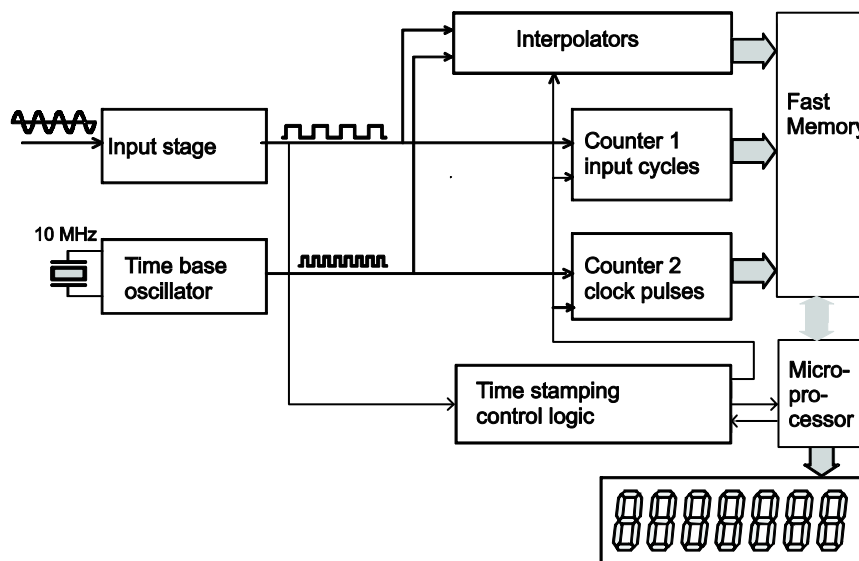

PICTURE 4 Block diagram for time stamping counter

Time stamping counters count the input signal trigger events and the time *continuously without interruptions*. In principle the counting proceeds indefinitely until the counting chain overflows and starts from zero again. With regular intervals (pacing intervals) you read the momentary content in the respective registers, as well as interpolation values, “in flight”, without interrupting the counter. The values (trigger events/“Events” and the time/“Time stamps”) are stored in a fast memory. The readout is always synchronized with the input trigger, i.e. the number of counted input cycles is always an exact number. Just as in reciprocal counters the uncertainty is in the reading out of time.

When a certain number of events have been stored – or when a certain time has elapsed – the data will be analyzed, post-processed and presented.

A frequency measurement over a certain measuring time, e.g. 1 second, can then contain hundreds or thousands of time stamped events, not only the final result after the measuring time as in common reciprocal counters. See picture 5.

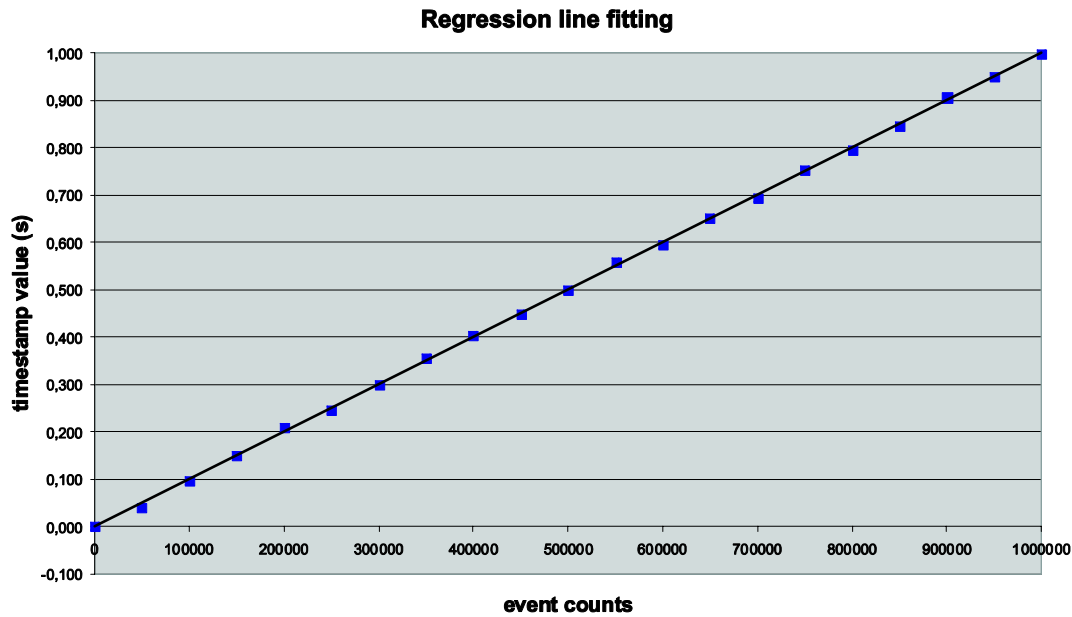

PICTURE 5 samples for time stamping counters

We have input cycles (Events) on the x-axis and the time (Time stamps) on the y-axis. The classic reciprocal counter contains only the value at the end of the measuring time (the initial value is 0,0). The inclination of the line between start and stop is the average period (total\_time/number of input cycles). The resolution of the measurement, i.e. the uncertainty of the line's inclination, depends only on the uncertainty of the start and stop points.

In time stamping counters we have instead a big amount of events along a straight line, each of them with a certain resolution. By applying an old well-known statistical method, linear regression, you can improve the resolution of the line's inclination (the period time) by a factor of  $2,4/\sqrt{N}$ , where  $N$ =the number of measuring points during the measuring time. With, for instance, 1000 points the resolution will be improved by a factor of 13. In pictures 6 and 7 we can see how the resolution (=the uncertainty of the line's inclination) is improved compared to the start-stop method.

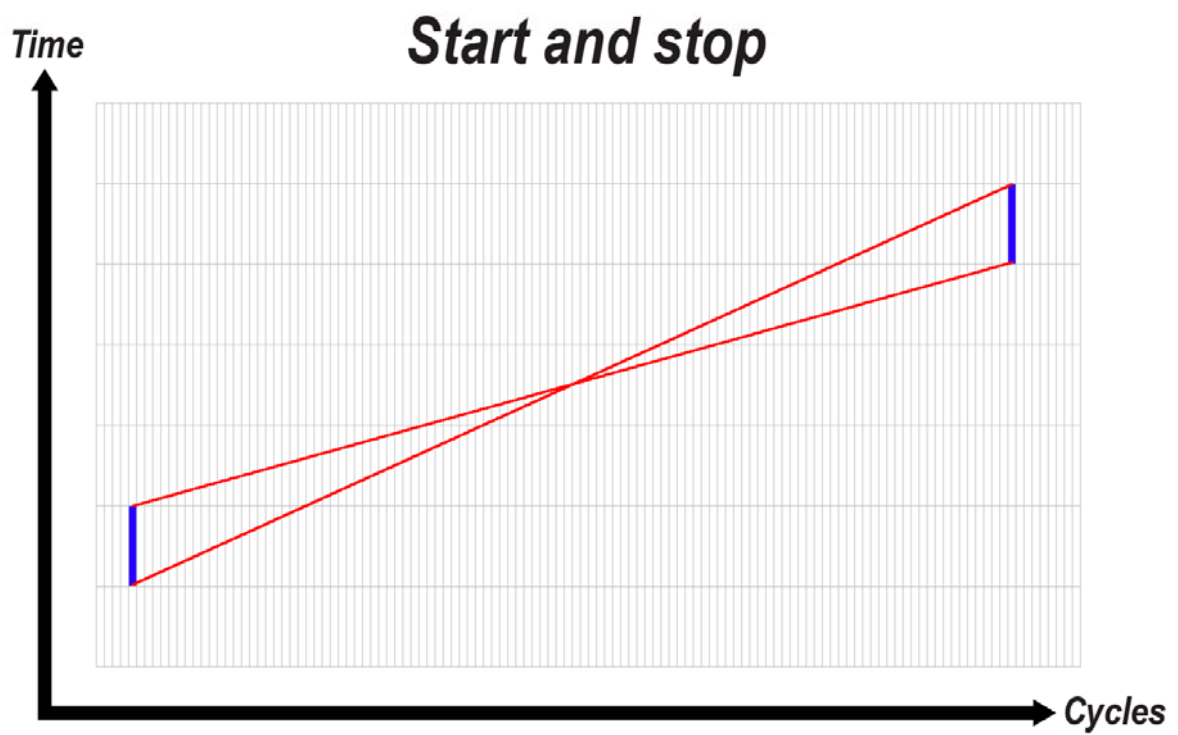

PICTURE 6 Resolution of the start-stop method

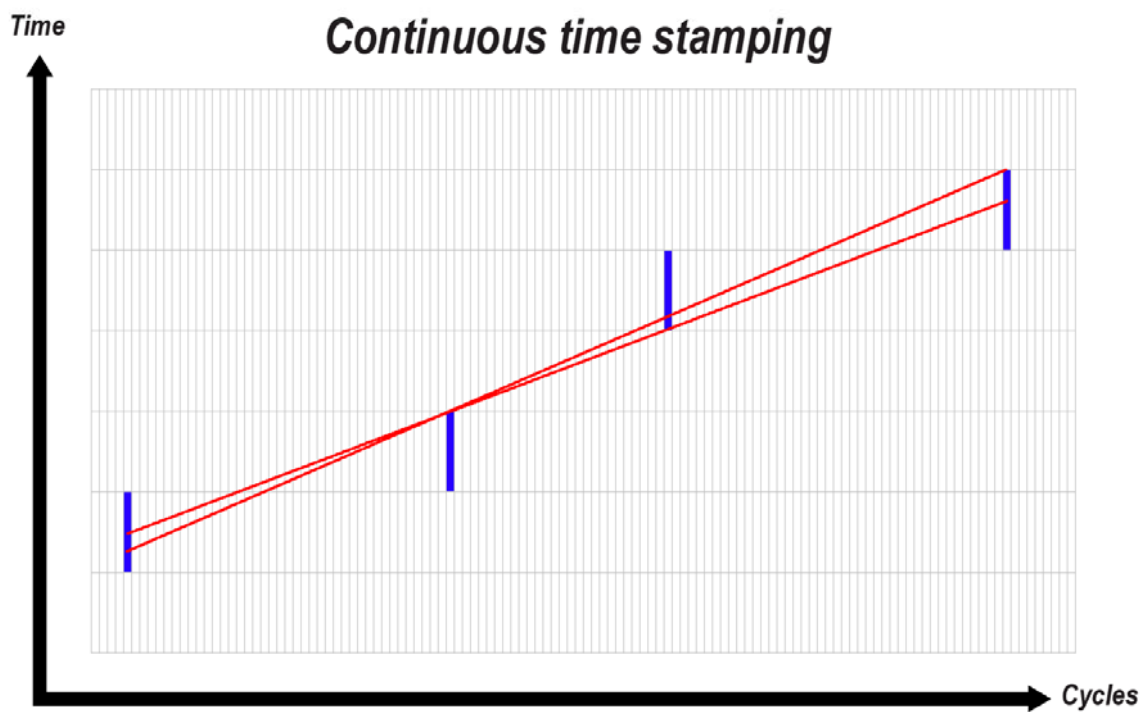

PICTURE 7 Resolution of the time stamping method

## Summary

We have seen that a continuously time stamping frequency counter makes it possible to improve resolution in frequency measurements by means of linear regression of a large number of “intermediate values” between start and stop. But there are also other advantages with this method that have not been mentioned in the article.

- The measurement is two-dimensional and gives an authentic time scale where you can relate individual trigger events in time to each other (classic reciprocal counters can only give individual values, without mutual time relationship)
- Measurement with an authentic time scale makes it possible to show frequency changes over time. The difference against the one-dimensional traditional counter is in principle the same as the difference between a voltmeter and an oscilloscope that shows voltage changes over time.
- Measurement with authentic time scale renders possible improved post-processed analysis of the data, for example FFT.
- You can make single period measurements “back-to-back”, that is without dead time. This is important in order to detect ”missing periods" and to follow all cycles in a sequence. The applications are many and different, from test of serial data communication to test of mechanical rotational sensors. Classic reciprocal counters will, at best, measure every other period.
- You can make frequency measurements “back-to-back”, that is without dead time. This is essential in order to calculate the Allan variance, which is important for characterizing the stability of oscillators. Classic reciprocal counters will always measure with dead time.

.....

Fact box 1

## Linear regression

The inclination of the regression line corresponds to the estimated average period time of the input signal ( $T^*$ ), and is calculated as:

$$T^* = \frac{n \sum x_k y_k - \sum x_k \sum y_k}{n \sum x_k^2 - (\sum x_k)^2}$$

$x_k$ =the number of cycles in sample No.  $k$

$y_k$ =the time stamping value in sample No.  $k$

$n$ =the number of samples

The uncertainty (variance) of the inclination  $T^*$  is

$$s^2(T^*) = \frac{s^2(y)}{\sum (x_i - \bar{x})^2} = \frac{s^2(y)}{s^2(x) \cdot (n-2)}$$

$s(y)$  is the normal rms resolution  $t_{RES}$  for an individual time stamp and  $s(x)$  is the standard

deviation of an approximate rectangular distribution ( $x_k = x_0 + \frac{kN}{n}$ ) i.e.  $s(x) \approx \sigma = \frac{N}{2\sqrt{3}}$  for large values of  $n$ , which leads to the relative resolution in period or frequency:

$$\frac{s(T^*)}{T^*} = \frac{s(f^*)}{f^*} = \frac{2\sqrt{3} \cdot t_{RES}}{MT \cdot \sqrt{n}}$$

$t_{RES}$ =resolution of an individual time stamp

$MT$ =Measuring time

$n$ =number of samples



\*\*\*\*\*

## Fact box 2



PICTURE 8 CNT-90 timer/Counter/Analyzer from Pendulum Instruments AB

Pendulum's Model CNT-90 Timer/Counter/Analyzer (picture 8) is continuously timestamping and can alternatively use start-stop counting or linear regression in order to improve the resolution. For the CNT-90 the resolution of an individual time stamp is  $t_{RES}=70$  ps. The number of samples that can be stored is 1,5 millions, and the sample speed is up to 250000 Sa/s. In a frequency measurement, the number of samples  $n$  during the measuring time is 1000 or less (depending on selected measurement time). For one second's measurement time, the resolution is approximately  $8 * 10^{-12}$  with linear regression and  $1 * 10^{-10}$  with start-stop.

The CNT-90 has an automatic measurement mode, where the regression method is chosen for measuring times  $\geq 200$  ms and the start-stop method for shorter measuring times. This is illustrated in picture 9 where the dashed line shows the resolution of the traditional start-stop method. In this automatic mode the resolution is improved for measuring times between 0,2 and 100 s.

Typical resolution CNT-90

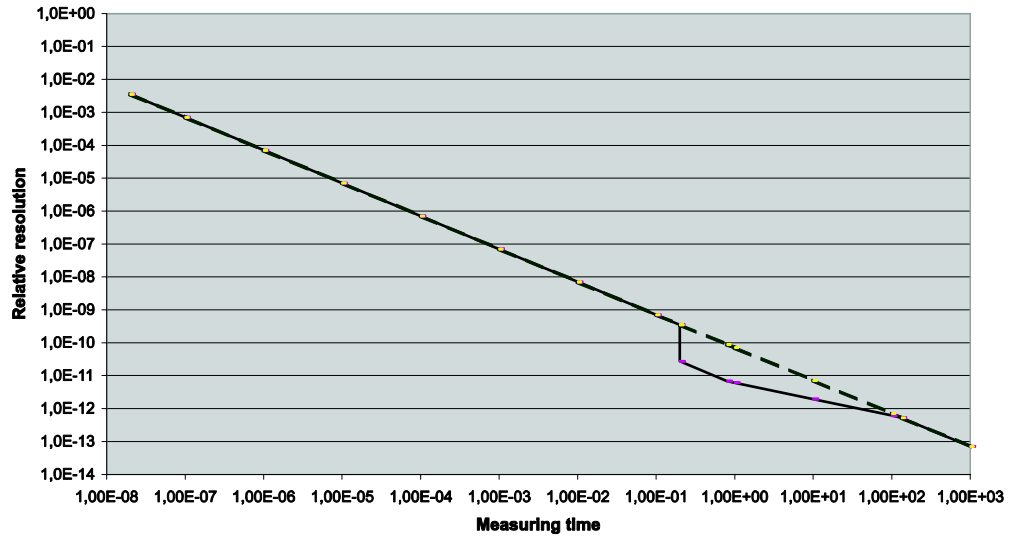

PICTURE 9 Resolution improvement for measuring times between 200ms and 100s in the CNT-90 automatic measuring mode.

\*\*\*\*\*

Fact box

### A small warning!

Linear regression assumes that the frequency is nominally constant during the measuring time. The method is good for reducing random variations and noise in the measuring process, but if the input signal is strongly modulated or has a considerable drift (for example a frequency sweep), then the start-stop method gives a more correct picture of the signal's average frequency. See picture 9 where we have excessive frequency drift and where the inclination of the regression line deviates from the line between start and stop (=the average frequency).

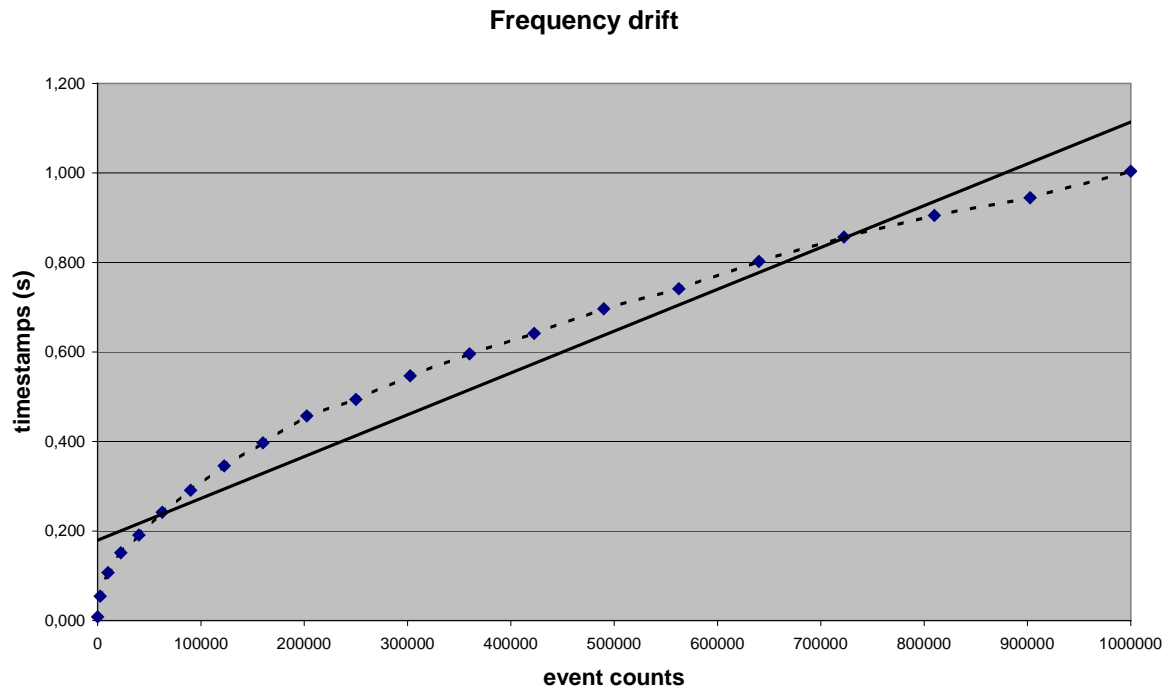

Figure 9. A regression line does not improve resolution if there is a frequency drift