



# **Agilent N1923/4A Wideband Power Sensor**

## **Service Guide**



**Agilent Technologies**

# Notices

© Agilent Technologies, Inc. 2011

No part of this manual may be reproduced in any form or by any means (including electronic storage and retrieval or translation into a foreign language) without prior agreement and written consent from Agilent Technologies, Inc. as governed by United States and international copyright laws.

## Manual Part Number

N1923-90003

## Edition

First Edition, Oct 31, 2011

Agilent Technologies, Inc.  
5301 Stevens Creek Blvd.  
Santa Clara, CA 95051 USA

## Warranty

**The material contained in this document is provided “as is,” and is subject to being changed, without notice, in future editions. Further, to the maximum extent permitted by applicable law, Agilent disclaims all warranties, either express or implied, with regard to this manual and any information contained herein, including but not limited to the implied warranties of merchantability and fitness for a particular purpose. Agilent shall not be liable for errors or for incidental or consequential damages in connection with the furnishing, use, or performance of this document or of any information contained herein. Should Agilent and the user have a separate written agreement with warranty terms covering the material in this document that conflict with these terms, the warranty terms in the separate agreement shall control.**

## Technology Licenses

The hardware and/or software described in this document are furnished under a license and may be used or copied only in accordance with the terms of such license.

## Restricted Rights Legend

U.S. Government Restricted Rights. Software and technical data rights granted to the federal government include only those rights customarily provided to end user customers. Agilent provides this customary commercial license in Software and technical data pursuant to FAR 12.211 (Technical Data) and 12.212 (Computer Software) and, for the Department of Defense, DFARS 252.227-7015 (Technical Data - Commercial Items) and DFARS 227.7202-3 (Rights in Commercial Computer Software or Computer Software Documentation).

## Safety Notices

### CAUTION

A **CAUTION** notice denotes a hazard. It calls attention to an operating procedure, practice, or the like that, if not correctly performed or adhered to, could result in damage to the product or loss of important data. Do not proceed beyond a **CAUTION** notice until the indicated conditions are fully understood and met.

---





### WARNING

A **WARNING** notice denotes a hazard. It calls attention to an operating procedure, practice, or the like that, if not correctly performed or adhered to, could result in personal injury or death. Do not proceed beyond a **WARNING** notice until the indicated conditions are fully understood and met.

---

## Safety and Regulatory Symbols

The following symbols on the device and in the documentation indicate precautions that must be taken to maintain safe operation of the device.

 <b>N10149</b>	<p>The C-Tick mark is a registered trademark of the Spectrum Management Agency of Australia. This signifies compliance with the Australian EMC Framework Regulations under the terms of the Radio Communications Act of 1992.</p>		<p>This product complies with the WEEE Directive (2002/96/EC) marking requirement. This affixed product label indicates that you must not discard this electrical/electronic product in domestic household waste.</p>
	<p>This symbol indicates the time period during which no hazardous or toxic substance elements are expected to leak or deteriorate during normal use. Forty years is the expected useful life of the product.</p>		<p>The CE mark is a registered trademark of the European Community. This CE mark shows that the product complies with all the relevant European Legal Directives.</p> <p>ICES/NMB-001 indicates that this ISM product complies with the Canadian ICES-001. Cet appareil ISM est conforme a la norme NMB-001 du Canada.</p> <p>ISM GRP.1 Class A indicates that this is an Industrial Scientific and Medical Group 1 Class A product.</p>

## General Safety Information

The following general safety precautions must be observed during all phases of operation, service, and repair of this device. Failure to comply with these precautions or with specific warnings elsewhere in this manual violates safety standards of design, manufacture, and intended use of the device. Agilent Technologies assumes no liability for the customer's failure to comply with these requirements.

### **WARNING**

**Before connecting the sensor to other instruments, ensure that all instruments are connected to the protective (earth) ground. Any interruption of the protective earth grounding will cause a potential shock hazard that could result in personal injury.**

---

### **CAUTION**

Repair or service that is not covered in this manual should only be performed by qualified personnel.

---

## Waste Electrical and Electronic Equipment (WEEE) Directive 2002/96/EC

This instruction complies with the WEEE Directive (2002/96/EC) marking requirement. This affixed product label indicates that you must not discard this electrical/electronic product in domestic household waste.

Product Category:

With reference to the equipment types in the WEEE Directive Annex 1, this device is classified as a “Monitoring and Control Instrument” product.

The affixed product label is as shown below:



### **Do not dispose in domestic household waste**

To return this unwanted device, contact your nearest Agilent office, or visit

[www.agilent.com/environment/product](http://www.agilent.com/environment/product)

for more information.

# Environmental Conditions

This device is designed for indoor use only. The following table shows the general environmental requirements for this device.

## Operating environment

Environmental conditions	Requirements
Temperature	0°C to 55°C (Operating)
Humidity	Maximum: 95% at 40°C (non-condensing) Minimum: 15% at 40°C (non-condensing)
Altitude	Operating up to 3000 m (9840 ft)

## Storage condition

Environmental conditions	Requirements
Temperature	-30°C to 70°C (Non-operating)
Humidity	Non-operating up to 90% at 65°C (non-condensing)
Altitude	Non-operating up to 15420 m (50000 ft)

## Regulatory information

The N1923/4A wideband power sensor complies with the following Electromagnetic Compatibility (EMC) requirements:

- IEC 61326-1:2005/EN 61326-1:2006
- Canada: ICES/NMB-001:Issue 4, June 2006
- Australia/New Zealand: AS/NZS CISPR11:2004

## Declaration of Conformity (DoC)

The Declaration of Conformity (DoC) for this device is available on the Web site. You can search the DoC by its product model or description.

<http://regulations.corporate.agilent.com/DoC/search.htm>

### NOTE

If you are unable to search for the respective DoC, contact your local Agilent representative.

---

## In This Guide...

### **1 General Information**

Chapter 1 provides the specifications and maintenance information of the N1923/4A.

### **2 Performance Verification and Adjustments**

Chapter 2 contains the performance verification procedures which verify that the N1923/4A is operating within its published specifications. This chapter also provides information on adjustments performed after a performance verification fails.

### **3 Theory of Operation**

Chapter 3 describes the operation and functions of the N1923/4A assembly.

### **4 Repair Guide**

Chapter 4 contains information on repair and replaceable parts of the N1923/4A. This chapter also explains how to assemble and disassemble the N1923/4A.

### **5 Contacting Agilent**

Chapter 5 explains the appropriate actions to take if you have a problem with your N1923/4A.



# Contents

- 1 General Information 1**
  - Specifications and Characteristics **2**
  - Cleaning **3**
    - Connector care **3**
  
- 2 Performance Verification and Adjustments 5**
  - Equipment List **6**
  - Voltage Standing Wave Ratio (VSWR) Performance Verification **7**
  - Sensor Accuracy Performance Verification **8**
  - System-Level Rise and Fall Time Performance Verification **11**
  - Zero Set Performance Verification **15**
  - Adjustments **17**
  
- 3 Theory of Operation 19**
  - Theory of Operation **20**
  
- 4 Repair Guide 23**
  - Repair **24**
  - Replaceable Parts **25**
  - Disassembly/Reassembly Procedure **27**
    - Disassembly procedure **27**
    - Reassembly procedure **27**
  
- 5 Contacting Agilent 29**
  - Introduction **30**
    - Instrument serial numbers **30**
    - Recommended calibration interval **31**
  - Returning the N1923/4A for Service **32**
    - Packaging the N1923/4A for shipment **32**





# 1 General Information

Specifications and Characteristics 2  
Cleaning 3

This chapter provides the specifications and maintenance information of the N1923/4A wideband power sensor.

## Specifications and Characteristics

For the N1923/4A specifications and characteristics, refer to the *N1923/4A User's Guide*.

## Cleaning

Use a clean, water-dampened cloth to clean the body of the N1923/4A.

### Connector care

A solution of pure isopropyl or ethyl alcohol can be used to clean the connector but make sure to keep in mind on its flammable nature.

#### CAUTION

- The RF connector beads deteriorate when contacted by hydrocarbon compounds such as acetone, trichloroethylene, carbon tetrachloride, and benzene.
  - Do not attempt to clean the connector with anything metallic such as pins or paper clips.
  - Clean the connector only at a static free workstation. Electrostatic discharge to the center pin of the connector will render the N1923/4A inoperative.
- 

Clean the connector face by first using a blast of compressed air. If the compressed air fails to remove contaminants, use a foam swab dipped in isopropyl or ethyl alcohol. If the swab is too big, use a round wooden toothpick wrapped in a lint-free cloth dipped in isopropyl or ethyl alcohol.

## **1 Introduction**



## 2 Performance Verification and Adjustments

Voltage Standing Wave Ratio (VSWR) Performance Verification	7
Sensor Accuracy Performance Verification	8
System-Level Rise and Fall Time Performance Verification	11
Zero Set Performance Verification	15
Adjustments	17

This chapter contains the performance verification procedures which verify that the N1923/4A is operating within its published specifications. This chapter also provides information on adjustments performed after a performance verification fails.



## Equipment List

The following equipment are required for performance verification:

Equipment	Critical specification	Recommended Agilent model number/part number
Signal generator	Power range: -50 dBm to +22 dBm at 1 GHz Output resistance: 50 $\Omega$	E8257D
Oscilloscope	Analog bandwidth: 1 GHz and above	Infiniium MSO 9104A
Network analyzer	Frequency range: 10 MHz to 40 GHz or above Dynamic range: 94 dB Trace noise: <0.006 dB	E8361A/E8361C/E8363B/E8363C
Peak power analyzer	Absolute accuracy: $\pm 0.8\%$ Rise/fall time: <5 nsecs $\pm$ % error Overshoot: 0.5%	8990B
Calibration kit	Frequency range: DC to 18 GHz or above	85054A/85054D/85056A/85056D
Diode detector (negative)	SMB connector	33334EZ
Power splitter	Two-resistor type power splitter, N-type (f) Maximum frequency: 18 GHz	11667A
Power meter	Dual-channel peak power meter, compatible with P-Series and N8480 Series power sensors Absolute accuracy: $\pm 0.8\%$	N1912A
Power sensor	Frequency: 50 MHz or above Power range: -30 dBm to +20 dBm Standing wave ratio (SWR): $\leq 1.15$ at 50 MHz	N8481A/N8487A
Wideband power sensor	Power range: -30 dBm to +20 dBm SWR: $\leq 1.20$ at 1 GHz	N1921A/N1922A
Cable adapter	11730A sensor cable adapter	N1911A-200
N-type-to-SMA adapter	N-type (m) to 2.4 mm SMA (f)	11903D
Trigger cable	BNC (m) to SMB (f) Characteristic impedance: 50 $\Omega$	U2032A



## Voltage Standing Wave Ratio (VSWR) Performance Verification

VSWR is a measure of how efficiently an RF power is transmitted from an RF power source. In real systems, mismatched impedances between the RF source and load can cause some of the power to be reflected back towards the source and vary the VSWR.

This test requires the following equipment:

- network analyzer (E8361A/C or E8363B/C)
- calibration kit (85054A/D, 85056A/D)

### Test procedure

- 1 Turn on the network analyzer and allow it to warm up for approximately an hour.
- 2 Set the start frequency of the network analyzer to 50 MHz and stop frequency to 18 GHz (for the N1923A) and 40 GHz (for the N1924A).
- 3 Calibrate the network analyzer using the appropriate calibration kit (85054A/D for the N1923A and 85056A/D for the N1924A). Perform calibration for the open, short, and load circuits of the network analyzer.
- 4 After calibration, connect the N1923/4A to the test port of the network analyzer. Turn on **Correction** on the network analyzer to perform the VSWR measurement.
- 5 Compare the measured results to the specifications in the table below. If the verification fails, refer to “[Adjustments](#)” on page 17.

Sensor model	Frequency band	Maximum SWR
N1923A	50 MHz to 10 GHz	1.2
	10 GHz to 18 GHz	1.26
N1924A	50 MHz to 10 GHz	1.2
	10 GHz to 18 GHz	1.26
	18 GHz to 26.5 GHz	1.3
	26.5 GHz to 40 GHz	1.5

## Sensor Accuracy Performance Verification

The purpose of this verification is to verify the accuracy of the N1923/4A after a period of usage to ensure that the N1923/4A is still within its published specifications.

This test requires the following equipment:

- PSG analog signal generator (E8257D)
- power sensor (N1921/2A, N8481/7A)
- power meter (N1912A, N1911A-200)
- power splitter (11667A)

### Test procedure

- 1 Turn on the E8257D and N1912A. Allow them to warm up for approximately an hour.
- 2 Connect the standard sensor (N8481/7A) to the N1912A channel A and the incident sensor (N1921/2A) to the N1912A channel B.
- 3 The equipment setup is as shown below:

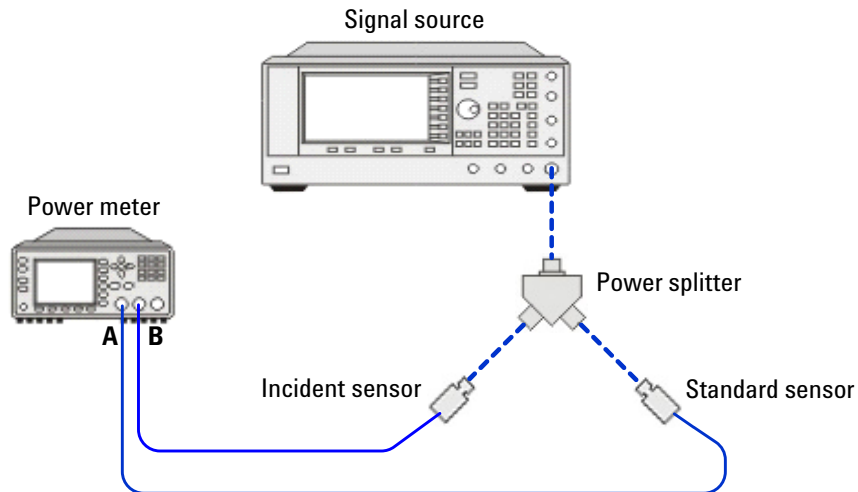

- 4 Zero and calibrate the standard and incident sensors on channels A and B respectively.

- 5 Set the frequency of the signal source to 50 MHz and power level to 0 dBm. Turn on the RF output.
- 6 Set the frequency of the N1912A channels A and B to the same frequency as the signal source.
- 7 Measure the standard power ( $P_{STD}$ ) of channel A and incident power ( $P_{INC1}$ ) of channel B. Compute and record the power ratio ( $P_{ratio}$ ) of these channels for the current frequency and power level, based on the following equation:

$$P_{ratio}(dB) = P_{STD} - P_{INC1}$$

- 8 Repeat steps 5 to 7 for other frequencies with the same power level.
- 9 Turn off the RF output of the signal source.
- 10 Remove the standard sensor from the N1912A channel A.
- 11 Connect the device-under-test (DUT, N1923/4A) to the N1912A channel A.
- 12 The equipment setup is as shown below:

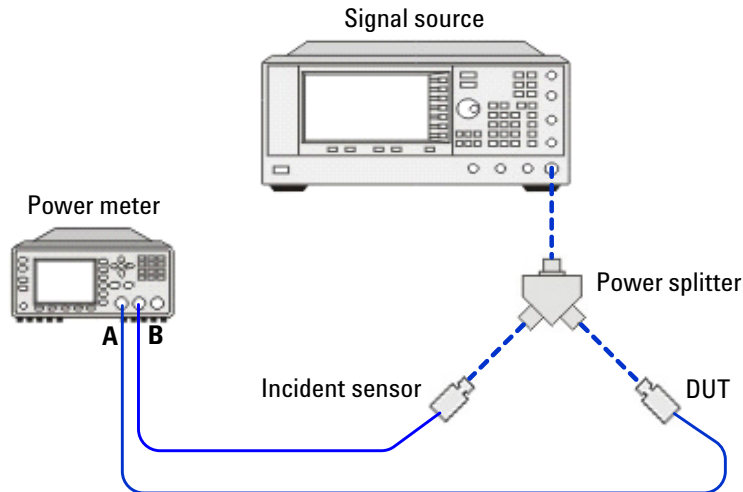

- 13 Zero and calibrate the DUT on the N1912A channel A.
- 14 Repeat steps 5 and 6.
- 15 Measure and record the power readings of channels A and B for the current frequency and power level, as  $P_{DUT}$  (for channel A) and  $P_{INC2}$  (for channel B).

## 2 Performance Verification and Adjustments

**16** Repeat steps 14 and 15 for other frequencies with the same power level.

**17** Turn off the RF output of the signal source.

**18** Compute the accuracy error of the DUT for each frequency being measured at the same power level, using the following equations:

$$\text{Accuracy error (dB)} = P_{DUT} - (P_{INC2} + (P_{STD} - P_{INC1}))$$

$$\text{Accuracy error (\%)} = \text{Antilog} \left[ \frac{P_{DUT} - (P_{INC2} + (P_{STD} - P_{INC1}))}{10} - 1 \right] \times 100$$

**19** Compare the computed accuracy errors to the calibration uncertainty values in the table below. If the verification fails, refer to “Adjustments” on page 17.

### NOTE

The accuracy error measured in this verification includes a combination of errors for linearity, calibration factor, and temperature compensation.

Sensor model	Frequency band	Calibration uncertainty <sup>[1]</sup>
N1923A	50 MHz to 500 MHz	4.5%
	500 MHz to 1 GHz	4.0%
	1 GHz to 10 GHz	4.0%
	10 GHz to 18 GHz	5.0%
N1924A	50 MHz to 500 MHz	4.3%
	500 MHz to 1 GHz	4.2%
	1 GHz to 10 GHz	4.4%
	10 GHz to 18 GHz	4.7%
	18 GHz to 26.5 GHz	5.9%
	26.5 GHz to 40 GHz	6.0%

[1] Beyond 70% humidity, an additional 0.6% must be added to the values.

**20** Repeat steps 5 to 19 by sweeping through the power level from –25 dBm to 10 dBm with a frequency of 50 MHz.

## System-Level Rise and Fall Time Performance Verification

The rise and fall time performance of the instrument path must be quantified accurately. This test however, is more of a system-level verification, validating the rise and fall time with the 8990B peak power analyzer using an actual RF pulse.

This test requires the following equipment:

- PSG analog signal generator (E8257D)
- Peak power analyzer (8990B)
- Diode detector (33334EZ)
- Oscilloscope (Infiniium MSO 9104A)
- Trigger cable (U2032A)
- Sensor (N1923/4A, as DUT)

System specifications:

- Rise/fall time:  $<5 \text{ nsecs} \pm \% \text{ error}$  (Refer to [Figure 3-3](#) on page 21)
- Overshoot: 0.5%

### Test procedure

- 1 Turn on the E8257D, oscilloscope, and 8990B.
- 2 Allow the system to warm up for approximately an hour before starting the measurement.
- 3 Generate an RF pulse signal (with the following recommended signal profile) from the E8257D.
  - Frequency: 1 GHz
  - Power level: 10 dBm
  - Pulse period: 10  $\mu$ secs
  - Duty cycle: 50%

The pulse signal is characterized using a diode detector which feeds to the oscilloscope. This is to verify that the rise/fall time of the RF pulse measured by the oscilloscope is  $<5 \text{ nsecs}$  and its overshoot is  $<0.5\%$ .

## 2 Performance Verification and Adjustments

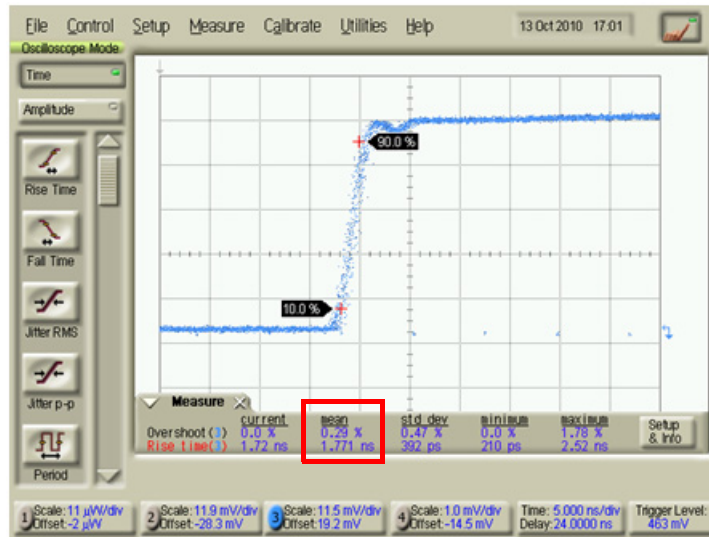

**Figure 2-1** Screenshot of the oscilloscope measurement display

4 Connect the N1923/4A to the E8257D and 8990B as shown below:

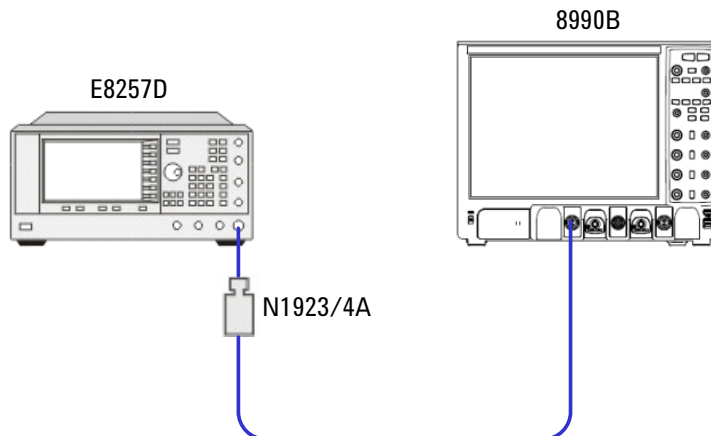

5 Generate the same pulse signal as previous.

6 Press **Auto Scale** on the 8990B to scale the pulse signal to the optimum display.

7 Turn off **Video Bandwidth** on the 8990B.

8 Measure and record the rise/fall time of the pulse signal from the 8990B in the table below.

Measured points	Specification	Measured rise time (sec)	Pass/fail
Bandwidth: OFF, Power level: 10 dBm, Pulse period: 0.2 $\mu$ secs, Duty cycle: 50%	5n		
Bandwidth: OFF, Power level: 10 dBm, Pulse period: 1 $\mu$ sec, Duty cycle: 50%	5n		
Bandwidth: OFF, Power level: 10 dBm, Pulse period: 10 $\mu$ secs, Duty cycle: 50%	5n		
Bandwidth: OFF, Power level: 10 dBm, Pulse period: 100 $\mu$ secs, Duty cycle: 50%	5n		
Bandwidth: LOW, Power level: 10 dBm, Pulse period: 0.2 $\mu$ secs, Duty cycle: 50%	60n		
Bandwidth: LOW, Power level: 10 dBm, Pulse period: 1 $\mu$ sec, Duty cycle: 50%	60n		
Bandwidth: LOW, Power level: 10 dBm, Pulse period: 10 $\mu$ secs, Duty cycle: 50%	60n		
Bandwidth: LOW, Power level: 10 dBm, Pulse period: 100 $\mu$ secs, Duty cycle: 50%	60n		
Bandwidth: MED, Power level: 10 dBm, Pulse period: 0.2 $\mu$ secs, Duty cycle: 50%	25n		
Bandwidth: MED, Power level: 10 dBm, Pulse period: 1 $\mu$ sec, Duty cycle: 50%	25n		
Bandwidth: MED, Power level: 10 dBm, Pulse period: 10 $\mu$ secs, Duty cycle: 50%	25n		
Bandwidth: MED, Power level: 10 dBm, Pulse period: 100 $\mu$ secs, Duty cycle: 50%	25n		
Bandwidth: HIGH, Power level: 10 dBm, Pulse period: 0.2 $\mu$ secs, Duty cycle: 50%	13n		

## 2 Performance Verification and Adjustments

Measured points	Specification	Measured rise time (sec)	Pass/fail
Bandwidth: HIGH, Power level: 10 dBm, Pulse period: 1 $\mu$ sec, Duty cycle: 50%	13n		
Bandwidth: HIGH, Power level: 10 dBm, Pulse period: 10 $\mu$ secs, Duty cycle: 50%	13n		
Bandwidth: HIGH, Power level: 10 dBm, Pulse period: 100 $\mu$ secs, Duty cycle: 50%	13n		

- 9 Repeat the above steps for the pulse signal with different pulse periods and different video bandwidth settings. Record all the readings in the above table.
- 10 Compare the recorded readings to the specifications in the table. If the verification fails, refer to “Adjustments” on page 17.



## Zero Set Performance Verification

Zero set is defined as the amount of residual offset error that is present following a zeroing operation. This offset error is caused by contamination from several sources, including circuit noise. This test is a system-level verification which requires an 8990B.

This test requires the following equipment:

- Peak power analyzer (8990B)
- Sensor (N1923/4A, as DUT)

System specification: <200 nsecs

### Test procedure

- 1 Turn on the 8990B.
- 2 Connect the N1923/4A to the 8990B as shown below. Allow the system to warm up for approximately an hour.

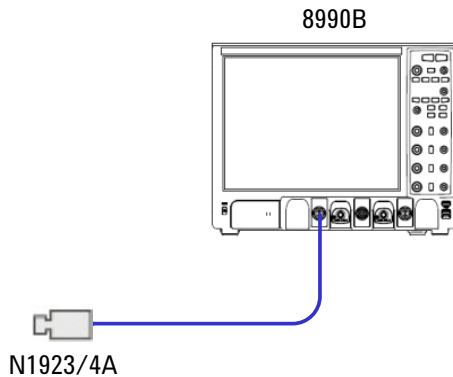

- 3 Set the channel 1 frequency to 50 MHz.
- 4 Perform zeroing and calibration for N1923/4A.
- 5 Set the horizontal scale of the display to the Linear scale.
- 6 Measure the average power.
- 7 Collect each mean value of the power reading for 1 minute.

## 2 Performance Verification and Adjustments

- 8 Calculate the mean of the collected data for the total number of readings in 1 minute.
- 9 Calculate the standard deviation ( $\sigma$ ) of the data.
- 10 The zero set is computed using the following equation:  
$$\text{Zero set} = \text{mean} + k \cdot \sigma$$
, where  $k = 2$  due to 95% confidence level
- 11 Repeat the above steps for channel 4.
- 12 If the calculated zero set value is out of specification ( $>200$  nsecs), refer to “Adjustments” on page 17.

## Adjustments

Adjustments are usually required on a yearly basis. They are normally performed only after a performance verification has indicated that some parameters are out of specification. Performance verification must be completed after any repairs that may have altered the characteristics of the N1923/4A.

The N1923/4A is required to be returned to Agilent for adjustments. To arrange this, contact the Agilent Service Center. Refer to “[Contacting Agilent](#)” on page 29 or **Contact us** on the last page of this guide for information.

## **2 Performance Verification and Adjustments**

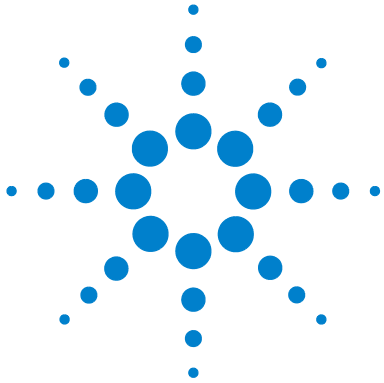

## 3 Theory of Operation

Theory of Operation 20

This chapter describes the operation and functions of the N1923/4A assembly.



## Theory of Operation

The N1923/4A is integrated with the internal zeroing and calibration capability, which eliminates the need for sensor calibration using an external reference source.

Agilent's patented technology (see [Figure 3-2](#)) integrates a DC reference source and switching circuits into each N1923/4A, so that you can zero and calibrate the N1923/4A while it is connected to a device-under-test. This feature removes the need for connection and disconnection from the calibration source, thereby reducing test times, measurement uncertainty, and wear and tear on connectors. It is especially useful in manufacturing and automated test environments where every second and every connection counts. The N1923/4A can be embedded within test fixtures without the need to switch in reference signals.

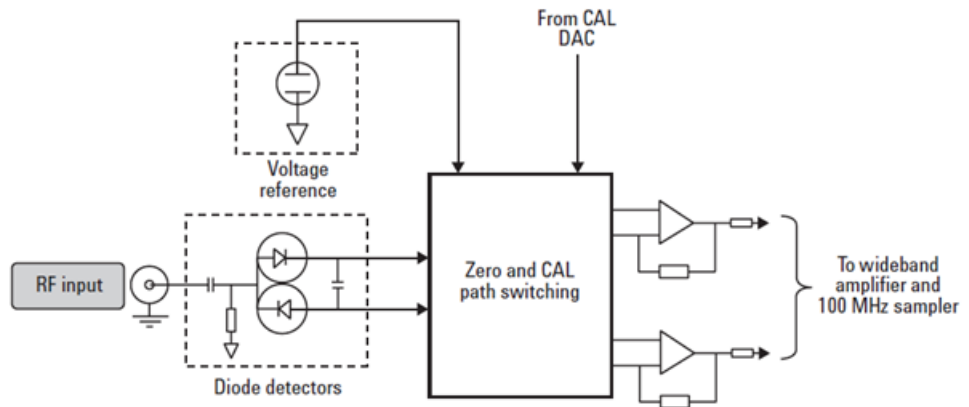

**Figure 3-2** Internal zeroing and calibration block diagram

To ensure the accuracy of power measurements and improve measurement speed, the N1923/4A uses a four-dimensional (4-D) modeling technique that measures input power, frequency, temperature, and output voltage across the N1923/4A specified measurement ranges. Data from this 4-D model is generated during Agilent's initial factory calibration of the N1923/4A and stored in EEPROM.

All the compensation data is downloaded to the power meter/peak power analyzer at power-on or when the N1923/4A is connected. Advanced algorithms are used to quickly and accurately evaluate the N1923/4A against this model, without requiring the power meter/peak power analyzer to interpolate the calibration factors and linearity curves. If you run tests in which the frequency changes often, such as testing multi-carrier amplifiers on different bands, you will notice a marked improvement in measurement speed.

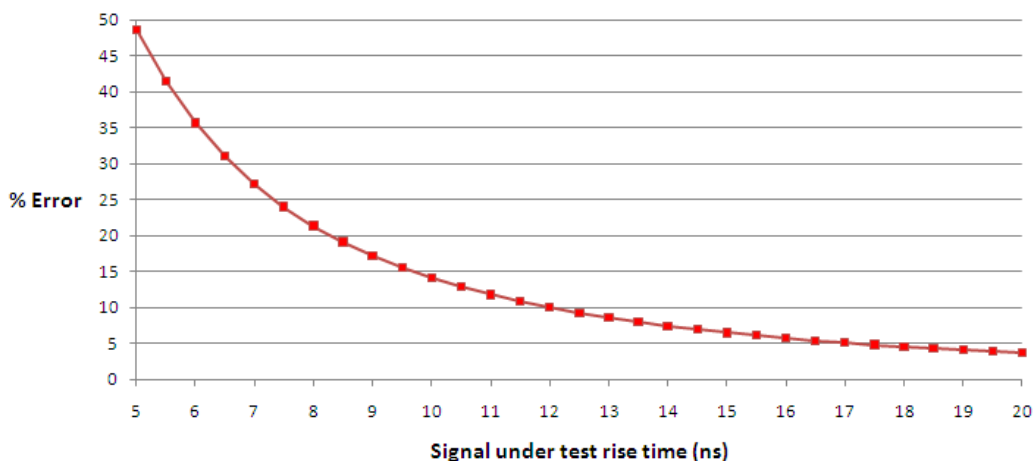

**Figure 3-3** Measured rise time percentage error versus signal-under-test rise time

Although the rise time specification is  $\leq 5$  nsecs, this does not mean that the combination of peak power meter, peak power analyzer, and N1923/4A can accurately measure a signal with a known rise time of 5 nsecs. The measured rise time is the root sum of the squares (RSS) of the signal-under-test rise time and the system rise time (5 nsecs):

$$\sqrt{((SignalUnderTestRiseTime)^2 + (SystemRiseTime)^2)}$$

The % error is:

$$\frac{(MeasuredRiseTime - SignalUnderTestRiseTime)}{(SignalUnderTestRiseTime)} \times 100$$

### **3 Introduction**





## 4 Repair Guide

Repair 24

Replaceable Parts 25

Disassembly/Reassembly Procedure 27

Disassembly procedure 27

Reassembly procedure 27

This chapter contains information on repair and replaceable parts of the N1923/4A. This chapter also explains how to assemble and disassemble the N1923/4A.



## **Repair**

There are no serviceable parts inside the N1923/4A. If the N1923/4A is defective, send it back to the nearest Agilent Service Center for repair. The entire “module” of the defective N1923/4A will be replaced with an appropriate replacement module listed in [Table 4-1](#).

## Replaceable Parts

### NOTE

Replaceable parts are only available for the use of Agilent Service Center personnel and are not available for trade sales.

The following figure illustrates the parts breakdown of the N1923/4A which identifies all the replaceable parts. If you want to order a part, quote the Agilent part number, specify the quantity required, and address the order to the nearest Agilent Sales and Service office.

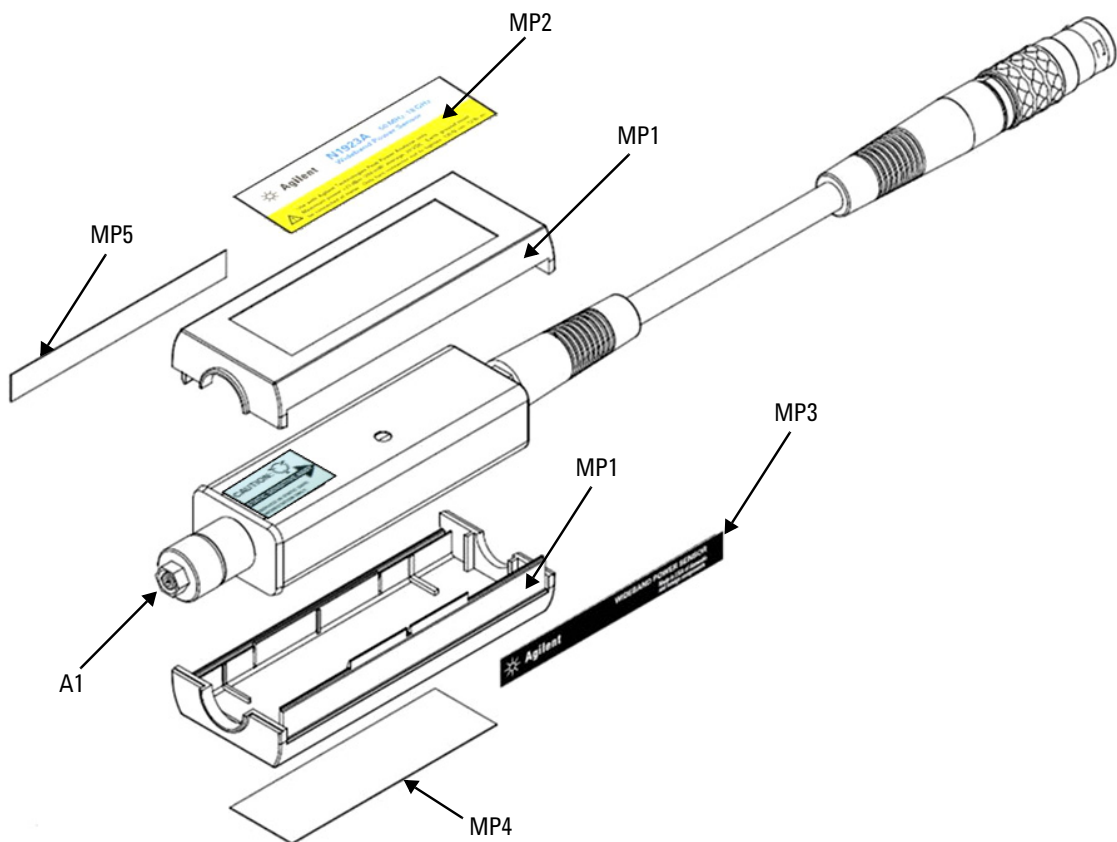

**Figure 4-1** Illustrated parts breakdown

**Table 4-1** Replaceable parts list for the N1923/4A

Reference designation	Option	Part number	Quantity	Description
<b>A1</b>				
N1923A	N1923A-105	N1923-60001	1	N1923A replacement module, fixed 1.5 m (5 ft) cable
N1923A	N1923A-106	N1923-60002	1	N1923A replacement module, fixed 3.0 m (10 ft) cable
N1923A	N1923A-107	N1923-60003	1	N1923A replacement module, fixed 10.0 m (31 ft) cable
N1924A	N1924A-105	N1924-60001	1	N1924A replacement module, fixed 1.5 m (5 ft) cable
N1924A	N1924A-106	N1924-60002	1	N1924A replacement module, fixed 3.0 m (10 ft) cable
N1924A	N1924A-107	N1924-60003	1	N1924A replacement module, fixed 10.0 m (31 ft) cable
<b>Chassis part</b>				
MP1	–	N1920-20001	2	Plastic housing/shield
MP2	–	N1923-84301	1	Top label (N1923A)
MP2	–	N1924-84302	1	Top label (N1924A)
MP3	–	5188-3998	1	Side label
MP4	–	N1920-80002	1	Bottom label
MP5	–	N1920-80004	1	Side ESD label

## Disassembly/Reassembly Procedure

**CAUTION**

Disassemble the N1923/4A only in a static-free workstation. Electrostatic discharge renders the N1923/4A inoperative.

### Disassembly procedure

Use the following steps to disassemble the N1923/4A:

- At the rear of the N1923/4A, insert the blade of a screwdriver between the plastic shells (refer to [Figure 4-2](#)). To prevent damage to the plastic shells, use a screwdriver blade as wide as the slot between the two shells.
- Pry alternately at both sides of the connector until the plastic shells are apart. Remove the shells and the magnetic shields.



**Figure 4-2** Removing the N1923/4A shell

### Reassembly procedure

Replace the magnetic shields and the plastic shells. Snap the plastic shells together.





## 5 Contacting Agilent

Introduction	30
Instrument serial numbers	30
Recommended calibration interval	31
Returning the N1923/4A for Service	32
Packaging the N1923/4A for shipment	32

This chapter explains the appropriate actions to take if you have a problem with your N1923/4A.



## Introduction

This section provides the information on what to do if you encounter problems with your N1923/4A.

If you wish to contact Agilent to enquire about the N1923/4A, from service problems to ordering information, refer to **Contact us** on the last page of this guide.

If you wish to return the N1923/4A to Agilent, refer to [“Returning the N1923/4A for Service”](#) on page 32.

## Instrument serial numbers

Agilent makes frequent improvements to its products to enhance their performance, usability, and reliability. Agilent service personnel have access to complete records of design changes for each instrument. The information is based on the serial number and option designation of each N1923/4A.

Whenever you contact Agilent about your N1923/4A, have a complete serial number available. This ensures you obtain the most complete and accurate service information. The serial number can be obtained from the serial number label.

The serial number label is attached to the side panel of the N1923/4A. This label has two instrument identification entries. The first provides the instrument serial number and the second provides the identification number for each option built into the instrument.

The serial number is divided into two parts: the prefix (two letters and the first four numbers), and the suffix (the last four numbers).

- The prefix letters indicate the country of manufacture. This code is based on the ISO international country code standard, and is used to designate the specific country of manufacture for the individual product. The same product number could be manufactured in two different countries. In this case, the individual product serial numbers would reflect different country of manufacture codes. The prefix also consists of four numbers. This is a code identifying the date of the last major design change.



- The suffix indicates an alphanumeric code which is used to ensure unique identification of each product throughout Agilent.

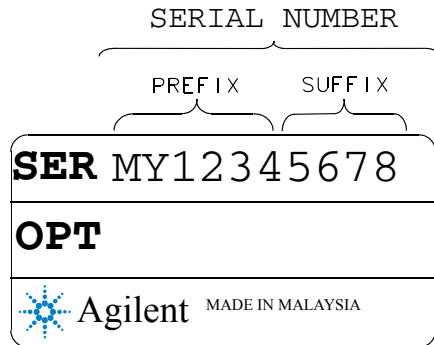

**Figure 5-3** Serial number

## Recommended calibration interval

Agilent recommends a one-year calibration cycle for the N1923/4A.

## Returning the N1923/4A for Service

Use the information in this section if you need to return your N1923/4A to Agilent.

### Packaging the N1923/4A for shipment

Use the following procedure to package the N1923/4A for shipment to Agilent for servicing:

- Be as specific as possible about the nature of the problem. Send a copy of any information on the performance of the N1923/4A.

#### CAUTION

Damage to the instrument can result from using packaging material other than those specified. Never use styrene pellets in any shape as packaging material. They do not adequately cushion the instrument or prevent it from shifting in the carton. Styrene pellets cause instrument damage by generating static electricity and by lodging in the instrument panels.

- Use the original packaging material or a strong shipping container made of double-walled, corrugated cardboard with 91 kg (200 lb.) bursting strength. The carton must be large and strong enough to accommodate the N1923/4A and allow at least 3 to 4 inches on all sides of the N1923/4A for packing material.
- Surround the N1923/4A with at least 3 to 4 inches of packing material, or enough to prevent the N1923/4A from moving in the carton. If packing foam is not available, the best alternative is SD-240 Air Cap™ from Sealed Air Corporation (Commerce, CA 90001). Air Cap looks like a plastic sheet covered with 1-1/4-inch air filled bubbles. Use the pink Air Cap to reduce static electricity. Wrap the N1923/4A several times in the material as protection and to prevent it from moving in the carton.
- Seal the shipping container securely with strong nylon adhesive tape.
- Mark the shipping container as “FRAGILE, HANDLE WITH CARE” to ensure careful handling.
- Retain copies of all shipping papers.

**www.agilent.com**

### **Contact us**

To obtain service, warranty, or technical assistance, contact us at the following phone or fax numbers:

United States:

(tel) (800) 829 4444 (fax) 800 829 4433

Canada:

(tel) (877) 894 4414 (fax) 800 746 4866

China:

(tel) 800 810 0189 (fax) 800 820 2816

Europe:

(tel) 31 20 547 2111

Japan:

(tel) 0120 (421) 345 (fax) 0120 421 678

Korea:

(tel) 080 769 0800 (fax) (080) 769 0900

Latin America:

(tel) 305 269 7500

Taiwan:

(tel) 0800 047 866 (fax) 0800 286 331

Other Asia Pacific Countries:

(tel) (65) 6375 8100 (fax) (65) 6755 0042

Or visit Agilent World Wide Web at:

[www.agilent.com/find/assist](http://www.agilent.com/find/assist)

Product specifications and descriptions in this document are subject to change without notice. Always refer to the Agilent Web site for the latest revision.

© Agilent Technologies, Inc. 2011

First Edition, Oct 31, 2011

N1923-90003



**Agilent Technologies**