

Errata

Title & Document Type: 8560E/EC Service Guide

Manual Part Number: 08560-90157

Revision Date: December 1999

HP References in this Manual

This manual may contain references to HP or Hewlett-Packard. Please note that Hewlett-Packard's former test and measurement, semiconductor products and chemical analysis businesses are now part of Agilent Technologies. We have made no changes to this manual copy. The HP XXXX referred to in this document is now the Agilent XXXX. For example, model number HP8648A is now model number Agilent 8648A.

About this Manual

We've added this manual to the Agilent website in an effort to help you support your product. This manual provides the best information we could find. It may be incomplete or contain dated information, and the scan quality may not be ideal. If we find a better copy in the future, we will add it to the Agilent website.

Support for Your Product

Agilent no longer sells or supports this product. You will find any other available product information on the Agilent Test & Measurement website:

www.tm.agilent.com

Search for the model number of this product, and the resulting product page will guide you to any available information. Our service centers may be able to perform calibration if no repair parts are needed, but no other support from Agilent is available.

Service Guide

HP 8560E and 8560EC Spectrum Analyzers



Manufacturing Part Number: 08560-90157 Supersedes: 08560-90149

Printed in USA

December 1999

© Copyright 1990 – 1999 Hewlett-Packard Company

Notice

Hewlett-Packard makes no warranty of any kind with regard to this material, including but not limited to, the implied warranties of merchantability and fitness for a particular purpose. Hewlett-Packard shall not be liable for errors contained herein or for incidental or consequential damages in connection with the furnishing, performance, or use of this material.

All Rights Reserved. Reproduction, adaptation, or translation without prior written permission is prohibited, except as allowed under the copyright laws.

The information contained in this document is subject to change without notice.

Certification

Hewlett-Packard Company certifies that this product met its published specifications at the time of shipment from the factory.

Hewlett-Packard further certifies that its calibration measurements are traceable to the United States National Institute of Standards and Technology, to the extent allowed by the Institute's calibration facility, and to the calibration facilities of other International Standards Organization members.

General Safety Considerations

The following safety notes are used throughout this manual. Familiarize yourself with these notes before operating this instrument.

WARNING

Warning denotes a hazard. It calls attention to a procedure which, if not correctly performed or adhered to, could result in injury or loss of life. Do not proceed beyond a warning note until the indicated conditions are fully understood and met.

CAUTION

Always use the three-prong AC power cord supplied with this product. Failure to ensure adequate grounding may cause product damage.

WARNING **This is a Safety Class 1 Product (provided with a protective earth ground incorporated in the power cord). The mains plug shall be inserted only in a socket outlet provided with a protected earth contact. Any interruption of the protective conductor inside or outside of the product is likely to make the product dangerous. Intentional interruption is prohibited.**

CAUTION *Before this instrument is switched on, make sure its primary power circuitry has been adapted to the voltage of the ac power source.*

Failure to set the ac power input to the correct voltage could cause damage to the instrument when the ac power cable is plugged in.

This product conforms to Enclosure Protection IP 2 0 according to IEC-529. The enclosure protects against finger access to hazardous parts within the enclosure; the enclosure does not protect against the entrance of water.

CAUTION Caution denotes a hazard. It calls attention to a procedure that, if not correctly performed or adhered to, could result in damage to or destruction of the instrument. Do not proceed beyond a caution sign until the indicated conditions are fully understood and met.

WARNING **No operator serviceable parts inside. Refer servicing to qualified personnel. To prevent electrical shock do not remove covers.**

WARNING ***Before this instrument is switched on, make sure it has been properly grounded through the protective conductor of the ac power cable to a socket outlet provided with protective earth contact.***

Any interruption of the protective (grounding) conductor, inside or outside the instrument, or disconnection of the protective earth terminal can result in personal injury.

If this instrument is used in a manner not specified by Hewlett-Packard Co., the protection provided by the instrument may be impaired.

There are many points in the instrument which can, if contacted, cause personal injury. Be extremely careful. Any adjustments or service procedures that require operation of the instrument with protective covers removed should be performed only by trained service personnel.

Warranty

This Hewlett-Packard instrument product is warranted against defects in material and workmanship for a period of one year from date of shipment. During the warranty period, Hewlett-Packard Company will, at its option, either repair or replace products that prove to be defective.

For warranty service or repair, this product must be returned to a service facility designated by Hewlett-Packard. Buyer shall prepay shipping charges to Hewlett-Packard and Hewlett-Packard shall pay shipping charges to return the product to Buyer. However, Buyer shall pay all shipping charges, duties, and taxes for products returned to Hewlett-Packard from another country.

Hewlett-Packard warrants that its software and firmware designated by Hewlett-Packard for use with an instrument will execute its programming instructions when properly installed on that instrument. Hewlett-Packard does not warrant that the operation of the instrument, or software, or firmware will be uninterrupted or error-free.

LIMITATION OF WARRANTY

The foregoing warranty shall not apply to defects resulting from improper or inadequate maintenance by Buyer, Buyer-supplied software or interfacing, unauthorized modification or misuse, operation outside of the environmental specifications for the product, or improper site preparation or maintenance.

NO OTHER WARRANTY IS EXPRESSED OR IMPLIED.
HEWLETT-PACKARD SPECIFICALLY DISCLAIMS THE IMPLIED WARRANTIES OF MERCHANTABILITY AND FITNESS FOR A PARTICULAR PURPOSE.

EXCLUSIVE REMEDIES

THE REMEDIES PROVIDED HEREIN ARE BUYER'S SOLE AND EXCLUSIVE REMEDIES. HEWLETT-PACKARD SHALL NOT BE LIABLE FOR ANY DIRECT, INDIRECT, SPECIAL, INCIDENTAL, OR CONSEQUENTIAL DAMAGES, WHETHER BASED ON CONTRACT, TORT, OR ANY OTHER LEGAL THEORY.

Contents

1. General Information

| | |
|---|----|
| Introduction | 24 |
| How to Use this Guide | 25 |
| Conventions followed in this guide: | 25 |
| Documentation Outline | 25 |
| Differences between HP 8560 EC-Series and E-Series Spectrum Analyzers | 26 |
| Instrument Variations | 27 |
| Serial Numbers and Repair Information | 29 |
| HP 8529B Test and Adjustment Module | 31 |
| Service Kit | 32 |
| Recommended Test Equipment | 33 |
| Electrostatic Discharge | 41 |
| Reducing Potential for ESD Damage | 42 |
| Static-Safe Accessories | 42 |
| Returning Instruments for Service | 43 |
| Service Tag | 43 |
| Original Packaging | 43 |
| Other Packaging | 43 |
| Sales and Service Offices | 46 |

2. Adjustment Procedures

| | |
|--|----|
| Introduction | 50 |
| Safety Considerations | 51 |
| Which Adjustments Should Be Performed? | 51 |
| Test Equipment | 51 |
| Adjustable and Factory-Selected Components | 51 |
| Adjustment Tools | 52 |
| Instrument Service Position | 52 |
| Using the TAM | 57 |
| Test Equipment | 57 |
| Adjustment Indicator | 57 |
| 1. High Voltage Power Supply Adjustment (8560E only) | 60 |
| Assembly Adjusted | 60 |
| Related Performance Test | 60 |
| Description | 60 |
| Equipment | 61 |
| Procedure | 61 |
| 2. Display Adjustment (8560E only) | 63 |
| Assembly Adjusted | 63 |
| Related Performance Test | 63 |
| Description | 63 |
| Equipment | 63 |
| Procedure | 64 |
| Preliminary Adjustments | 64 |
| Cutoff Adjustment | 64 |
| Deflection Adjustments | 64 |
| Intensity Adjustments | 65 |
| Fast Zero Span Adjustments | 68 |
| 3. IF Bandpass Adjustment | 70 |

Contents

| | |
|--|----|
| Assembly Adjusted | 70 |
| Related Performance Test | 70 |
| Description | 70 |
| Equipment | 71 |
| Procedure | 71 |
| 4. IF Amplitude Adjustments | 75 |
| Assembly Adjusted | 75 |
| Related Performance Tests | 75 |
| Equipment | 75 |
| A4 Log Amp/Cal Oscillator Amplitude Adjustment | 76 |
| Procedure | 77 |
| A5 Reference Attenuator Adjustment | 78 |
| A5 Adjustment Verification | 78 |
| 5. DC Log Amplifier Adjustments | 80 |
| Assembly Adjusted | 80 |
| Related Performance Tests | 80 |
| Equipment | 80 |
| A4 Limiter Phase Adjustment | 80 |
| Procedure | 81 |
| A4 Linear Fidelity Adjustment | 81 |
| Procedure | 81 |
| A4 Log Fidelity Adjustment | 82 |
| Procedure | 82 |
| 6. Sampling Oscillator Adjustment | 84 |
| Assembly Adjusted | 84 |
| Related Performance Test | 84 |
| Description | 84 |
| Equipment | 84 |
| Procedure | 84 |
| Sampling Oscillator Adjustment | 85 |
| Sampler Match Adjustment | 85 |
| 7. YTO Adjustment | 87 |
| Assembly Adjusted | 87 |
| Related Performance Tests | 87 |
| Description | 87 |
| Equipment | 87 |
| Procedure | 88 |
| YTO Main Coil Adjustments | 88 |
| YTO FM Coil Adjustments | 90 |
| 8. First LO Distribution Amplifier Adjustment | 91 |
| Assembly Adjusted | 91 |
| Related Performance Test | 91 |
| Description | 91 |
| Equipment | 91 |
| Procedure | 92 |
| 9. Tracking Generator Power Level Adjustments (Option 002) | 94 |
| Assembly Adjusted | 94 |
| Related Performance Test | 94 |
| Description | 94 |

Contents

| | |
|---|-----|
| Equipment | 94 |
| Procedure | 95 |
| 10. Frequency Response Adjustment | 97 |
| Assembly Adjusted | 97 |
| Related Performance Tests | 97 |
| Description | 97 |
| Equipment | 98 |
| Procedure | 99 |
| 11. Calibrator Amplitude Adjustment | 101 |
| Assembly Adjusted | 101 |
| Related Performance Test | 101 |
| Description | 101 |
| Equipment | 101 |
| Procedure | 102 |
| 12. 10 MHz Reference Adjustment-TCXO (Option 103) | 103 |
| Assembly Adjusted | 103 |
| Related Performance Test | 103 |
| Description | 103 |
| Equipment | 104 |
| Procedure | 104 |
| 13. Demodulator Adjustment | 105 |
| Assembly Adjusted | 105 |
| Related Performance Test | 105 |
| Description | 105 |
| Equipment | 106 |
| Procedure | 106 |
| 14. External Mixer Bias Adjustment | 108 |
| Assembly Adjusted | 108 |
| Related Performance Test | 108 |
| Description | 108 |
| Equipment | 108 |
| Procedure | 109 |
| 15. External Mixer Amplitude Adjustment | 110 |
| Assembly Adjusted | 110 |
| Related Performance Test | 110 |
| Description | 110 |
| Equipment | 111 |
| Procedure | 111 |
| 16. Signal ID Oscillator Adjustment (serial prefix 3517A and below) | 114 |
| Assembly Adjusted | 114 |
| Related Performance Test | 114 |
| Description | 114 |
| Equipment | 115 |
| Procedure | 116 |
| 17. 10 MHz Reference Adjustment-OCXO (Non-Option 103) | 118 |
| Assembly Adjusted | 118 |
| Related Performance Test | 118 |
| Description | 118 |
| Equipment | 119 |

Contents

| | |
|---|-----|
| Procedure | 119 |
| 18. Tracking Oscillator Adjustment | |
| (Option 002) | 122 |
| Assembly Adjusted | 122 |
| Related Performance Test | 122 |
| Description | 122 |
| Equipment | 122 |
| Procedure | 123 |
| 19. 16 MHz PLL Adjustment | 126 |
| Assembly Adjusted | 126 |
| Related Performance Tests | 126 |
| Description | 126 |
| Equipment | 127 |
| Procedure | 127 |
| 20. 600 MHz Reference Adjustment | |
| (serial prefix 3406A and above) | 130 |
| Assembly Adjusted | 130 |
| Related Performance Test | 130 |
| Description | 130 |
| Equipment | 130 |
| Procedure | 130 |
| 2a. Adjustment Procedures: HP 3335A Source not Available | |
| What You'll Find in This Chapter | 132 |
| Required Test Equipment | 133 |
| 4a. IF Amplitude Adjustments | 134 |
| Assembly Adjusted | 134 |
| Related Performance Tests | 134 |
| Equipment | 134 |
| A4 Log Amp/Cal Oscillator Amplitude Adjustment | 135 |
| Procedure | 136 |
| A5 Reference Attenuator Adjustment | 137 |
| A5 Adjustment Verification | 137 |
| 5a. DC Log Amplifier Adjustments | 139 |
| Assembly Adjusted | 139 |
| Related Performance Tests | 139 |
| Equipment | 139 |
| A4 Limiter Phase Adjustment | 141 |
| Procedure | 141 |
| A4 Linear Fidelity Adjustment | 141 |
| Procedure | 142 |
| A4 Log Fidelity Adjustment | 143 |
| Procedure | 143 |
| 3. Assembly Replacement | |
| Introduction | 146 |
| Access to Internal Assemblies | 147 |
| Cable Color Code | 148 |

Contents

| | |
|--|-----|
| Procedure 1. Spectrum Analyzer Cover | 149 |
| Removal/Replacement | 149 |
| Procedure 2A. A1 Front Frame/A18 LCD (8560EC) | 150 |
| Removal of the Front Frame | 150 |
| Removal of the Display Driver Board, Inverter Board, and LCD | 152 |
| Removal of the Backlights | 153 |
| Removal of the Line Switch from the Front Panel | 153 |
| Removal of the Keyboard | 155 |
| Replacement of the Front Frame | 155 |
| Replacement of the Display Driver Board, Inverter Board, and LCD | 157 |
| Replacing the Backlights | 158 |
| Replacement of the Line Switch | 159 |
| Replacement of the Keyboard | 159 |
| Procedure 2B. A1 Front Frame/A18 CRT (8560E) | 160 |
| Removal | 160 |
| Replacement | 165 |
| Procedure 3. A1A1 Keyboard/Front Panel Keys | 169 |
| Removal | 169 |
| Replacement | 169 |
| Procedure 4. A1A2 RPG | 170 |
| Removal | 170 |
| Replacement | 170 |
| Procedure 5. A2, A3, A4, and A5 Assemblies | 171 |
| Removal | 171 |
| Replacement | 172 |
| Procedure 6A. A6 Power Supply Assembly (8560EC) | 178 |
| Removal | 178 |
| Replacement | 180 |
| Procedure 6B. A6 Power Supply Assembly (8560E) | 181 |
| Removal | 181 |
| Replacement | 182 |
| Procedure 7. A6A1 High Voltage Assembly (8560E only) | 185 |
| Removal | 185 |
| Replacement | 187 |
| Procedure 8. A7 through A13 Assemblies | 189 |
| A7 1st LO Distribution Amplifier | 191 |
| A8 Low Band Mixer | 192 |
| A9 Input Attenuator | 192 |
| A10 Tracking Generator (Option 002) | 194 |
| A11 YTO | 195 |
| A13 Second Converter | 196 |
| Procedure 9. A14 and A15 Assemblies | 197 |
| Removal | 197 |
| Replacement | 198 |
| Procedure 10. A16 FADC/A17 CRT Driver (8560E) | 200 |
| Removal | 200 |
| Replacement | 201 |
| Procedure 11. B1 Fan | 203 |
| Removal/Replacement | 203 |

Contents

| | |
|--|------|
| Procedure 12. BT1 Battery | .204 |
| Removal/Replacement | .204 |
| Procedure 13. Rear Frame/Rear Dress Panel | .205 |
| Removal | .205 |
| Replacement | .207 |
| Procedure 14. W3 Line Switch Cable (8560E) | .210 |
| Removal | .210 |
| Replacement (Using Contact Removal Tool, HP Part Number 8710-1791) | .215 |
| Replacement (without Contact Removal Tool) | .216 |
| Procedure 15. EEROM (A2U501 or A2U500) | .219 |
| Removal/Replacement | .219 |
| Procedure 16. A21 OCXO (Non-Option 103) | .221 |
| Removal | .221 |
| Replacement | .222 |
| | |
| 4. Replaceable Parts | |
| Introduction | .224 |
| Ordering Information | .225 |
| Direct Mail-Order System | .225 |
| Direct Phone-Order System | .225 |
| Parts List Format | .226 |
| Firmware-Dependent Part Numbers | .227 |
| | |
| 5. Major Assembly and Cable Locations | |
| Introduction | .268 |
| | |
| 6. General Troubleshooting | |
| Introduction | .282 |
| Assembly Level Text | .282 |
| Block Diagrams | .282 |
| Assembly Test Points | .282 |
| Ribbon Cables | .283 |
| Service Cal Data Softkey Menus | .288 |
| Troubleshooting to a Functional Section | .290 |
| Using the TAM | .292 |
| Diagnostic Functions | .292 |
| TAM Requirements | .292 |
| Test Connectors | .293 |
| Inconsistent Results | .293 |
| Erroneous Results | .294 |
| Blank Display (8560E only) | .294 |
| Automatic Fault Isolation | .294 |
| Manual Probe Troubleshooting | .296 |
| Cal Oscillator Troubleshooting Mode | .296 |
| Error Messages | .298 |
| Viewing Multiple Messages | .299 |
| Error Message Elimination | .299 |
| System Analyzer Programming Errors | |

Contents

| | |
|---|-----|
| (100 to 150) | 300 |
| ADC Errors (200 to 299) | 301 |
| LO and RF Hardware/Firmware Failures (300 to 399) | 302 |
| Automatic IF Errors (400 to 599) | 312 |
| System Errors (600 to 651) | 324 |
| Digital and Checksum Errors (700 to 799) | 324 |
| Battery Problem (718) | 326 |
| Model Number Error (719) | 326 |
| System Errors (750 to 759) | 326 |
| Fast ADC Error (760) | 327 |
| Option Module Errors (800 to 899) | 327 |
| User-Generated Errors (900 to 999) | 327 |
| Block Diagram Description | 329 |
| RF Section | 331 |
| Synthesizer Section | 333 |
| IF Section | 335 |
| ADC/Interface Section | 337 |
| Controller Section | 339 |
| Display/Power Supply Section | 340 |

7. ADC/Interface Section

| | |
|---|-----|
| Introduction | 354 |
| Troubleshooting Using the TAM | 357 |
| Automatic Fault Isolation | 357 |
| Keyboard/RPG Problems | 360 |
| Keyboard Interface | 360 |
| RPG Interface | 361 |
| Triggering or Video Gating Problems | 363 |
| Preselector Peaking Control (Real Time DAC) | 366 |
| Flatness Control (RF Gain DACs) | 367 |
| A3 Assembly Video Circuits | 369 |
| Log Offset/Log Expand | 371 |
| Video MUX | 372 |
| Video Filter | 372 |
| Video Filter Buffer Amplifier | 374 |
| Positive/Negative Peak Detectors | 374 |
| Peak Detector Reset | 376 |
| Rosenfell Detector | 377 |
| ADC MUX | 378 |
| Variable Gain Amplifier (VGA) | 380 |
| Track and Hold | 380 |
| A3 Assembly ADC Circuits | 381 |
| ADC Control Signals | 381 |
| ADC Start/Stop Control | 382 |
| ADC ASM | 383 |
| ADC | 383 |
| Ramp Counter | 384 |
| A3 Assembly Control Circuits | 385 |
| Analog Bus Drivers | 385 |

Contents

| | |
|--|-----|
| Analog Bus Timing | 386 |
| Interface Strobe Select | 387 |
| A16 Assembly Fast ADC Circuits | |
| (8560E with Option 007) | 389 |
| Video Input Scaling Amplifiers and Limiter | 389 |
| 8-Bit Flash ADC | 390 |
| Peak/Pit Detection | 391 |
| 32 K-Byte Static RAM | 392 |
| A16 Assembly Fast ADC Control Circuits (8560E with Option 007) | 393 |
| CPU Interface and Control Registers | 393 |
| Reference Clock | 397 |
| Clock and Sample Rate Generator | 397 |
| Trigger | 398 |
| 316-Bit Post-Trigger Counter | 398 |
| 15-Bit (32 K) Circular Address Counter | 399 |
| Video Trigger Comparator | 399 |
| | |
| 8. IF Section | |
| Introduction | 406 |
| Troubleshooting Using the TAM | 408 |
| Troubleshooting the Log Amplifier with the TAM | 409 |
| Troubleshooting A5 with the TAM | 409 |
| Troubleshooting the Cal Oscillator with the TAM | 413 |
| Automatic IF Adjustment | 415 |
| Parameters Adjusted | 416 |
| Requirements | 417 |
| Performance Test Failures | 419 |
| IF Gain Uncertainty Performance Test | 419 |
| Scale Fidelity Performance Test | 420 |
| Resolution Bandwidths Performance Tests | 420 |
| Log Amplifier Assembly (P/O A4) | 421 |
| Log Amplifier | 421 |
| Linear Amplifiers | 422 |
| Video Offset | 423 |
| Video Output | 424 |
| Frequency Counter Prescaler/Conditioner | 425 |
| AM/FM Demodulator | 425 |
| 4.8 kHz IF Filters | 426 |
| 10.7 MHz IF Filters | 426 |
| 4.8 kHz and 10.7 MHz IF Filters | 427 |
| 10.6952 MHz VCXO | 428 |
| Input Switch | 428 |
| LO Switch | 428 |
| Synchronous Detector | 429 |
| Log Offset/Gain Compensation | 430 |
| Video MUX | 431 |
| A5 IF Assembly | 432 |
| IF Signature | 433 |
| Common IF Signature Problems | 441 |

Contents

| | |
|---|-----|
| 1 MHz Resolution Bandwidth Problems | 445 |
| 30 kHz Resolution Bandwidth Problems | 447 |
| 3 kHz and 10 kHz Resolution Bandwidth Problems | 448 |
| Step Gains | 449 |
| Cal Oscillator Assembly (P/O A4) | 450 |
| Cal Oscillator Unlock at Beginning of IF Adjust | 451 |
| Inadequate CAL OSC AMPTD Range | 452 |
| 300 Hz to 3 kHz Resolution Bandwidth Out of Specification | 453 |
| Low-Pass Filter | 459 |
| Sweep Generator | 460 |
| AM/FM Demodulation, Audio Amplifier, and Speaker | 460 |
| | |
| 9. Controller Section | |
| Introduction | 470 |
| Troubleshooting Using the TAM (8560E) | 471 |
| Blank Display | 471 |
| Digital Signature Analysis –DSA (8560E) | 474 |
| Display Problems (8560E) | 475 |
| Line Generators | 475 |
| Blanking | 476 |
| Display Jumbled or Trace Off Screen | 478 |
| Intensity | 482 |
| Bad Characters or Graticule | 483 |
| Long Lines Dimmer than Short Lines | 483 |
| Analog Zero-Span Problems (8560E only) | 486 |
| Frequency-Count Marker Problems (8560EC) | 487 |
| Frequency-Count Marker Problems (8560E) | 488 |
| Frequency Counter (8560EC) | 489 |
| Frequency Counter (8560) | 491 |
| Video Input Scaling Amplifiers and Limiter (8560EC) | 493 |
| 12-Bit Flash ADC (8560EC) | 495 |
| 32 K-Byte Static RAM (8560EC) | 496 |
| Reference Clock (8560EC) | 497 |
| 16 MHz Harmonic Filter (8560EC) | 498 |
| State- and Trace-Storage Problems | 499 |
| Keyboard Problems | 500 |
| | |
| 10. Synthesizer Section | |
| Introduction | 506 |
| Synthesizer Troubleshooting Section | 508 |
| Test Setup Troubleshooting | 514 |
| Troubleshooting Using the TAM | 515 |
| General PLL Troubleshooting | 520 |
| PLL Locked at Wrong Frequency | 520 |
| Unlocked PLL | 521 |
| Unlocked Reference PLL (100 MHz VCXO) | 524 |
| Operation (100 MHz VCXO) | 524 |
| Troubleshooting (100 MHz VCXO) | 524 |

Contents

| | |
|--|------|
| Third LO Driver Amplifier (100 MHz VCXO) | .528 |
| Unlocked Reference PLL (600 MHz SAWR) | .529 |
| Operation (600 MHz SAWR) | .529 |
| Troubleshooting (600 MHz SAWR) | .529 |
| Third LO driver amplifier (600 MHz SAWR) | .533 |
| Unlocked Offset Lock Loop (Sampling Oscillator) | .534 |
| Operation | .534 |
| Troubleshooting | .534 |
| Unlocked YTO PLL | .538 |
| Operation | .538 |
| Troubleshooting an Unlocked YTO PLL | .540 |
| Unlocked Fractional N PLL | .547 |
| Operation | .547 |
| Confirming an Unlocked Condition | .547 |
| Fractional N PLL | .548 |
| Frequency Span Accuracy Problems | .555 |
| Determining the First LO Span | .555 |
| Confirming Span Problems | .556 |
| YTO Main Coil Span Problems (LO spans >20 MHz) | .556 |
| YTO FM Coil Span Problems (LO spans 2.01 MHz to 20 MHz) | .557 |
| Fractional N Span Problems (LO spans \leq 2 MHz) | .559 |
| First LO Span Problems (All Spans) | .559 |
| Phase Noise Problems | .561 |
| Phase Noise in Locked versus Lock-and-Roll Spans | .561 |
| Reference versus Reference PLL Phase Noise | .562 |
| Fractional N versus Offset PLL or YTO PLL Phase Noise | .562 |
| Fractional N PLL Phase Noise (08560-60062 and below only) | .562 |
| Sampler and Sampler IF | .563 |
| Sweep Generator Circuit (for Spectrum Analyzers with 100 s max. Sweep Time) | .565 |
| Sweep Generator Circuit (for Spectrum Analyzers with 2000 s max. Sweep Time) | .568 |
| A21 OCXO | .574 |

11. RF Section

| | |
|--------------------------------------|------|
| Introduction | .582 |
| Troubleshooting Using the TAM | .584 |
| Low Band Problems (30 Hz to 2.9 GHz) | .587 |
| Low Band Problems | .588 |
| A7 LODA (LO Distribution Amplifier) | .589 |
| A8 Low Band Mixer | .591 |
| A9 Input Attenuator | .592 |
| A13 Second Converter | .594 |
| A14 Frequency Control Assembly | .596 |
| A7 LODA Drive | .596 |
| A15 RF Assembly | .598 |
| Confirming a Faulty Third Converter | .598 |
| Confirming a Third Converter Output | .598 |
| Third Converter | .599 |
| Flatness Compensation Control | .600 |

Contents

| | |
|--|-----|
| Control Latches | 601 |
| SIG ID Oscillator (Option 008) | 602 |
| 10 MHz Reference | 603 |
| A10 Tracking Generator (Option 002) | 607 |
| Block Diagram Description | 607 |
| Output Goes Unleveled (ERR 900 or ERR 901) | 608 |
| Excessive Residual FM | 610 |
| Flatness Out-of-Tolerance | 610 |
| Vernier Accuracy Out-of-Tolerance | 611 |
| Harmonic/Spurious Outputs Too High | 612 |
| Power Sweep Not Functioning Properly | 613 |
| No Power Output | 613 |
| | |
| 12. Display/Power Supply Section | |
| Introduction | 618 |
| LCD Display (8560EC) | 619 |
| Overview of A17 Display Driver Board | 620 |
| Troubleshooting the LCD Display | 621 |
| Blank Display | 621 |
| Dim Display | 622 |
| Troubleshooting using the VGA port | 622 |
| Troubleshooting using part substitution | 622 |
| CRT Display (8560E) | 624 |
| Troubleshooting Using the TAM | 626 |
| Blank Display (Using the TAM) | 628 |
| Blank Display | 629 |
| Blanking Signal | 631 |
| Display Distortion | 632 |
| Focus Problems | 634 |
| Intensity Problems | 636 |
| Power Supply | 638 |
| Troubleshooting Using the TAM (8560E only) | 641 |
| A6 Power Supply Assembly | 642 |
| Dead Power Supply | 642 |
| Line Fuse Blowing | 644 |
| Supply Restarting Every 1.5 Seconds (Kick Start) | 644 |
| Low Voltage Supplies | 644 |
| High Voltage Supplies (8560E) | 645 |
| CRT Supply Dropping Out (8560E) | 646 |
| Blanking Signal (8560E) | 647 |
| Buck Regulator Control | 647 |
| DC-DC Converter Control | 648 |
| Power Up | 648 |
| | |
| 13. Component-Level Information Packets | |
| Introduction | 654 |

Figures

| | |
|---|-----|
| Figure 1-1 . Serial Number Label Example | 29 |
| Figure 1-2 . Earlier Serial Number Label Example | 30 |
| Figure 1-3 . Example of a Static-Safe Workstation | 41 |
| Figure 1-4 . HP 8560E/EC Shipping Container and Cushioning Materials | 45 |
| Figure 2-1 . High Voltage Power Supply Adjustment Setup | 61 |
| Figure 2-2 . Display Adjustment Setup | 63 |
| Figure 2-3 . CRT Adjust Pattern | 66 |
| Figure 2-4 . A2 Display Adjustment Locations | 67 |
| Figure 2-5 . IF Bandpass Adjustment Setup | 70 |
| Figure 2-6 . IF Amplitude Adjustment Setup | 75 |
| Figure 2-7 . IF Amplitude Adjustment Locations | 76 |
| Figure 2-8 . Sampler Adjustment Setup | 84 |
| Figure 2-9 . TAM Connector Pin Locations | 85 |
| Figure 2-10 . YTO Adjustment Setup | 87 |
| Figure 2-11 . YTO Adjustment Locations | 90 |
| Figure 2-12 . First LO Distribution Amplifier Adjustment Setup | 91 |
| Figure 2-13 . TAM Connector Pin Locations | 92 |
| Figure 2-14 . Tracking Generator Power Setup and Adjustment Locations | 95 |
| Figure 2-15 . Frequency Response Adjustment Setup | 98 |
| Figure 2-16 . Calibrator Amplitude Adjustment Setup | 101 |
| Figure 2-17 . 10 MHz Frequency Reference Adjustment Setup | 103 |
| Figure 2-18 . Demodulator Adjustment Setup | 105 |
| Figure 2-19 . Demodulator Adjustment Locations | 107 |
| Figure 2-20 . External Mixer Bias Adjustment Setup | 108 |
| Figure 2-21 . External Mixer Amplitude Adjustment Setup | 110 |
| Figure 2-22 . Signal ID Oscillator Adjustment Setup | 115 |
| Figure 2-23 . Signal ID Oscillator Adjustment Jumper Location | 116 |
| Figure 2-24 . 10 MHz Reference Adjustment Setup and Adjustment Location | 119 |
| Figure 2-25 . Tracking Oscillator Adjustment Setup | 123 |
| Figure 2-26 . 16 MHz PLL Adjustment Setup | 127 |
| Figure 2-27 . 16 MHz PLL Adjustment Location | 128 |
| Figure 2a-1 . IF Amplitude Adjustment Setup | 134 |
| Figure 2a-2 . IF Amplitude Adjustment Locations | 135 |
| Figure 2a-3 . IF Amplitude Adjustment Setup | 140 |
| Figure 2a-4 . IF Amplitude Adjustment Locations | 140 |
| Figure 3-1 . Hinged Assemblies | 149 |
| Figure 3-2 . LCD Assembly - Exploded View | 154 |
| Figure 3-3 . Discharging High Voltage on the CRT | 162 |
| Figure 3-4 . A9, A18, and Line Switch Assembly Mounting Screws | 163 |
| Figure 3-5 . Front Frame Mounting Screws | 164 |
| Figure 3-6 . Installing the CRT and front Frame Assemblies | 165 |
| Figure 3-7 . Placing the CRT into the Front Frame | 166 |
| Figure 3-8 . A2, A3, A4, and A5 Assembly Removal | 172 |
| Figure 3-9 . Assembly Cables (1 of 3) – EC-Series | 173 |
| Figure 3-10 . Assembly Cables (2 of 3) – EC-series | 174 |
| Figure 3-11 . Assembly Cables (3 of 3)– E-series | 174 |
| Figure 3-12 . Coaxial Cable Clip – EC-Series | 175 |
| Figure 3-13 . Coaxial Cable Clip – E-Series | 176 |
| Figure 3-14 . HP-IB and A1A1 W1 Cable Placement | 177 |
| Figure 3-15 . Power Supply Cover | 179 |
| Figure 3-16 . Power Supply Cover | 180 |
| Figure 3-17 . A6 Power Supply Connections | 183 |
| Figure 3-18 . Power Supply Cover | 184 |

Figures

| | |
|---|-----|
| Figure 3-19 . A17 CRT Driver Mounting Screws | 187 |
| Figure 3-20 . Assembly Locations | 190 |
| Figure 3-21 . RF Section Bias Connections | 191 |
| Figure 3-22 . A9 Mounting Screws at Right Frame | 193 |
| Figure 3-23 . A10 Tracking Generator Mounting Screws | 194 |
| Figure 3-24 . A11 Mounting Screws | 195 |
| Figure 3-25 . A14 and A15 Assembly Removal | 197 |
| Figure 3-26 . A14 and A15 Assembly Cables | 199 |
| Figure 3-27 . A16 and A17 Mounting Screws | 201 |
| Figure 3-28 . A16 Cable Routing | 202 |
| Figure 3-29 . Main Deck Screws | 207 |
| Figure 3-30 . A6 Power Supply Cover | 209 |
| Figure 3-31 . W3 Dress and Connection to A6 Power Supply | 212 |
| Figure 3-32 . Line Switch Mounting Screw and Cable Dress | 213 |
| Figure 3-33 . W3 Cable Connector | 214 |
| Figure 3-34 . Side Frame Mounting Screws | 217 |
| Figure 3-35 . A21 OCXO Mounting Screws | 222 |
| Figure 4-1 . Parts Identification, Assembly Mounting | 241 |
| Figure 4-2 . Parts Identification, Cover Assembly | 249 |
| Figure 4-3 . Parts Identification, Main Chassis (8560E) | 251 |
| Figure 4-4 . Parts Identification, RF Section | 253 |
| Figure 4-5 . Parts Identification, Front Frame (1 of 2), 8560E | 255 |
| Figure 4-5 . Parts Identification, Front Frame (2 of 2), Option 002 | 257 |
| Figure 4-6 . Parts Identification, Rear Frame (8560E) | 259 |
| Figure 4-7 . Parts Identification, Chassis (8560EC) | 261 |
| Figure 4-8 . Parts Identification, Front Frame (8560EC) | 263 |
| Figure 4-9 . Parts Identification, Rear Frame (8560EC) | 265 |
| Figure 5-1 . Hinged Assemblies | 270 |
| Figure 5-2 . Top View (A2 and A3 Unfolded) – EC-Series | 271 |
| Figure 5-3 . Top View (A2, A3, A4, and A5 Unfolded) – EC-Series | 272 |
| Figure 5-4 . Top View (A2 Unfolded) – E-Series | 273 |
| Figure 5-5 . Top View (A2 and A3 Unfolded) – E-Series | 274 |
| Figure 5-6 . Top View (A2, A3, A4, and A5 Unfolded) – E-Series | 275 |
| Figure 5-7 . Bottom View (A15 Unfolded) | 276 |
| Figure 5-8 . Bottom View (A15 and A14 Unfolded) | 277 |
| Figure 5-9 . Front End | 278 |
| Figure 5-10 . Rear View EC-Series | 279 |
| Figure 5-11 . Rear View E-Series | 279 |
| Figure 6-1 . Assembly Test Points | 284 |
| Figure 6-2 . Ribbon Cable Connections (1 of 3) | 285 |
| Figure 6-3 . Ribbon Cable Connections (2 of 3) | 286 |
| Figure 6-4 . Ribbon Cable Connections (3 of 3) - EC-Series Only | 287 |
| Figure 6-5 . Service Cal Data Menu | 289 |
| Figure 6-6 . Functional Sections | 330 |
| Figure 6-7 . Phase Lock Loops | 335 |
| Figure 6-8 . Simplified Block Diagram | 341 |
| Figure 6-9 . Overall Block Diagram (1 of 5) | 343 |
| Figure 6-9 . Overall Block Diagram (2 of 5) | 345 |
| Figure 6-9 . Overall Block Diagram (3 of 5) | 347 |
| Figure 6-9 . Overall Block Diagram (4 of 5) | 349 |
| Figure 6-9 . Overall Block Diagram (5 of 5) | 351 |
| Figure 7-1 . A3 Test Connectors | 357 |
| Figure 7-2 . A3 Interface Assembly Block Diagram | 401 |

Figures

| | |
|--|-----|
| Figure 7-3 . Fast ADC Block Diagram (Option 007 in E-series instruments) | 403 |
| Figure 8-1 . A4 and A5 Test Connectors | 408 |
| Figure 8-2 . IF Section Troubleshooting with the TAM | 412 |
| Figure 8-3 . IF Adjust Signature | 435 |
| Figure 8-4 . Detailed IF Adjust Signature (1) | 436 |
| Figure 8-5 . Detailed IF Adjust Signature (2) | 437 |
| Figure 8-6 . Detailed IF Adjust Signature (3) | 438 |
| Figure 8-7 . Detailed IF Adjust Signature (4) | 439 |
| Figure 8-8 . Detailed IF Adjust Signature (5) | 440 |
| Figure 8-9 . Noisy Signature | 442 |
| Figure 8-10 . Noise with Correct Shape | 443 |
| Figure 8-11 . Region B Amplitude Variation | 444 |
| Figure 8-12 . Region B Amplitude Offset | 445 |
| Figure 8-13 . Faulty Crystal Short | 446 |
| Figure 8-14 . Faulty LC Pole | 447 |
| Figure 8-15 . Faulty Crystal Symmetry | 448 |
| Figure 8-16 . Output Waveform, 10 kHz Resolution Bandwidth | 455 |
| Figure 8-17 . Output Waveform, 3 kHz Resolution Bandwidth | 456 |
| Figure 8-18 . Output Waveform, 1 kHz Resolution Bandwidth | 457 |
| Figure 8-19 . Output Waveform, 300 Hz Resolution Bandwidth | 458 |
| Figure 8-20 . Failed Crystal Set Symptoms | 459 |
| Figure 8-21 . A4 Log Amplifier/Cal Oscillator Block Diagram (1 of 2) | 463 |
| Figure 8-21 . A4 Log Amplifier/Cal Oscillator Block Diagram (2 of 2) | 465 |
| Figure 8-22 . A5 IF Assembly Block Diagram | 467 |
| Figure 9-1 . A2 Test Connectors | 472 |
| Figure 9-2 . Line Generator Output Waveforms | 476 |
| Figure 9-3 . Blanking Waveforms | 477 |
| Figure 9-4 . Expanded Blanking Waveforms | 478 |
| Figure 9-5 . Switch Driver Waveform LCHAR | 479 |
| Figure 9-6 . Distorted X/Y Line Generator Waveforms | 481 |
| Figure 9-7 . Expanded X/Y Line Generator Waveforms | 481 |
| Figure 9-8 . Normal X/Y Line Generator Waveforms | 482 |
| Figure 9-9 . Delta X Waveform | 484 |
| Figure 9-10 . Delta Y Waveform | 485 |
| Figure 9-11 . DEF1 Synchronization | 486 |
| Figure 9-12 . A2 Controller Block Diagram (E-Series) | 501 |
| Figure 9-13 . A2 Controller Block Diagram (EC-Series) | 503 |
| Figure 10-1 . YTO Loop Test Setup | 511 |
| Figure 10-2 . Sampler and Sampling Oscillator Test Setup | 512 |
| Figure 10-3 . A14 and A15 Test Connectors | 515 |
| Figure 10-4 . TAM Connector Pin Locations | 516 |
| Figure 10-5 . PLL Locked at Wrong Frequency | 521 |
| Figure 10-6 . Unlocked PLL | 522 |
| Figure 10-7 . Troubleshooting an Unlocked YTO PLL | 541 |
| Figure 10-8 . VCO Bias Voltages for A14 Assemblies 08560-60069 and Above | 551 |
| Figure 10-8a . VCO Bias Voltages for A14 boards(08560-60062 and below) | 552 |
| Figure 10-9 . Simplified Sweep Generator | 566 |
| Figure 10-10 . Simplified Sweep Generator during Retrace | 567 |
| Figure 10-11 . Simplified Synthesizer Section | 570 |
| Figure 10-12 . Simplified A14 Assembly Block Diagram | 571 |
| Figure 10-13 . Simplified A15 Assembly Block Diagram (100 MHz PLL) | 572 |
| Figure 10-13a . Simplified A15 Assembly Block Diagram (600 MHz PLL) | 573 |
| Figure 10-14 . Frequency Control Block Diagram | 575 |

Figures

| | |
|---|-----|
| Figure 10-15 . RF Block Diagram (for A15 08563-60054, 08563-60055, or 08563-60056) | 577 |
| Figure 10-16 . RF Block Diagram (for A15 <08563-60054, 08563-60055, or 08563-60056) | 579 |
| Figure 11-1 . A14 and A15 Test Connectors | 584 |
| Figure 11-2 . A7 LODA Drive | 597 |
| Figure 11-3 . 10 MHz Reference at A15J302 | 604 |
| Figure 11-4 . 10 MHz TTL Reference at U304 Pin 13 | 605 |
| Figure 11-5 . HP 8560E RF Section Troubleshooting Block Diagram | 615 |
| Figure 12-1 . Simplified Section Block Diagram | 620 |
| Figure 12-2 . Probe Power Socket | 621 |
| Figure 12-3 . Location of +5V supply pins on J1 of A17 and J8 of A2 | 623 |
| Figure 12-4 . Power Supply and CRT Block Diagram | 625 |
| Figure 12-5 . A17 Test Connector | 627 |
| Figure 12-6 . Probe Power Socket | 629 |
| Figure 12-7 . Simplified Power Supply Block Diagram | 639 |
| Figure 12-8 . Buck Regulator Waveform | 643 |
| Figure 12-9 . A17 CRT Driver Block Diagram | 649 |
| Figure 12-10 . A6 Power Supply Block Diagram | 651 |
| Figure 13-1 . HP 8560 EC-Series Interconnect Block Diagram | 657 |
| Figure 13-2 . HP 8560 E-Series Interconnect Block Diagram | 659 |

| | |
|---|-----|
| Table 1-1 . Instrument Variations | 27 |
| Table 1-2 . Service Kit Contents | 32 |
| Table 1-3 . Recommended Test Equipment | 34 |
| Table 1-4 . Static-Safe Accessories | 42 |
| Table 1-5 . Static-Safe Accessories | 45 |
| Table 1-6 . Hewlett-Packard Sales and Service Offices | 47 |
| Table 2-1 . Related Adjustments | 52 |
| Table 2-2 . Adjustable Components | 54 |
| Table 2-3 . Factory Selected Components | 56 |
| Table 2-4 . TAM Adjustments | 58 |
| Table 2-5 . Required Test Equipment for TAM | 58 |
| Table 2-6 . Factory-Selected LC Filter Capacitors | 72 |
| Table 2-7 . LC Factory-Selected Capacitor Selection | 72 |
| Table 2-8 . Factory-Selected XTAL Filter Capacitors | 73 |
| Table 2-9 . XTAL Factory-Selected Capacitor Selection | 74 |
| Table 2-10 . Capacitor Part Numbers | 74 |
| Table 2-11 . Sampling Adjustments | 86 |
| Table 2-12 . Conversion Loss Data | 112 |
| Table 2-13 . Tracking Oscillator Range Centering | 125 |
| Table 2a-1 . Recommended Test Equipment | 133 |
| Table 3-1 . Required Tools | 148 |
| Table 4-1 . Reference Designations | 227 |
| Table 4-2 . Abbreviations | 228 |
| Table 4-3 . Reference Designations, Abbreviations, and Multipliers (4 of 4) | 232 |
| Table 4-4 . Replaceable Parts | 233 |
| Table 4-5 . Assembly Mounting (see Figure 4-1) | 241 |
| Table 4-6 . Parts List, Cover Assembly (See Figure 4-2) – 8560E and 8560EC | 242 |
| Table 4-7 . Parts List, Main Chassis – 8560EC (see Figure 4-8) | 242 |
| Table 4-8 . Parts List, Main Chassis (See Figure 4-3) – 8560E | 243 |
| Table 4-9 . Parts List, RF Section – 8560E and 8560EC (see Figure 4-4) | 245 |
| Table 4-10 . Parts List, Front Frame – 8560EC (see Figure 4-9) | 245 |
| Table 4-11 . Parts List, Front Frame – 8560E (see Figure 4-5) | 246 |
| Table 4-12 . Parts List, Rear Frame – 8560EC (see Figure 4-10) | 247 |
| Table 4-13 . Parts List, Rear Frame – 8560E (see Figure 4-7) | 248 |
| Table 6-1 . Location of Assembly Troubleshooting Text | 291 |
| Table 6-2 . Location of Assembly Troubleshooting Text | 333 |
| Table 7-1 . W2 Control Cable Connections | 355 |
| Table 7-2 . Automatic Fault Isolation References | 358 |
| Table 7-3 . TAM Tests versus A3 Test Connectors | 359 |
| Table 7-4 . Keyboard Matrix | 360 |
| Table 7-5 . Counter Frequencies | 362 |
| Table 7-6 . Trigger MUX Truth Table | 363 |
| Table 7-7 . A3U102 Latch Outputs | 374 |
| Table 7-8 . HMUX_SELO/1 versus Detector Mode | 377 |
| Table 7-9 . Logic Levels at A3U108 | 379 |
| Table 7-10 . Demultiplexer A3U410 Truth Table | 387 |
| Table 7-11 . Demultiplexer A3U500 Truth Table | 388 |
| Table 7-12 . LP/Q Truth Table | 392 |
| Table 7-13 . Control Word at Primary Address (U3 and U4) | 394 |
| Table 8-1 . Automatic Fault Isolation References | 408 |
| Table 8-2 . TAM Tests versus Test Connectors | 410 |
| Table 8-3 . Sweep Width Settings | 414 |
| Table 8-4 . IF Gain Application Guidelines (ATTEN=10 dB) | 423 |

Tables

| | |
|---|-----|
| Table 9-1 . TAM Tests versus Test Connectors. | 471 |
| Table 9-2 . Gate Times. | 490 |
| Table 9-3 . Gate Times. | 492 |
| Table 10-1 . Center Frequency Tuning Values | 509 |
| Table 10-2 . Sampling Oscillator Test Frequencies | 513 |
| Table 10-3 . Measured Signal Line Location. | 516 |
| Table 10-4 . Automatic Fault Isolation References | 516 |
| Table 10-5 . TAM Tests versus Test Connectors. | 517 |
| Table 10-6 . TAM Tests versus Test Connectors. | 522 |
| Table 10-7 . Sampling Oscillator PLL Divide Numbers | 535 |
| Table 10-8 . Amplifier Polarities | 539 |
| Table 10-9 . Voltages in FM Coil and Main Loop Drivers | 545 |
| Table 10-10 . Main Coil Coarse and Fine DACs Voltages | 546 |
| Table 10-11 . Postscaler Divide Numbers | 548 |
| Table 10-12 . Unlocked Fractional N Troubleshooting Areas (08560-60069 and Above) | 549 |
| Table 10-13 . Unlocked Fractional N Troubleshooting Areas (08560-60062 and below) | 549 |
| Table 10-14 . Divider and Integrator Troubleshooting | 553 |
| Table 10-15 . Sweep Signal Destination versus Span | 555 |
| Table 10-16 . Harmonic Mixing Number versus Center Frequency | 556 |
| Table 10-17 . Settings of Sweep Switches. | 558 |
| Table 10-18 . Settings of Sweep Switches. | 561 |
| Table 11-1 . Automatic Fault Isolation References | 584 |
| Table 11-2 . TAM Tests versus Test Connectors. | 585 |
| Table 11-3 . Attenuator Pin Values | 593 |
| Table 11-4 . RF Section Mnemonic Table. | 606 |
| Table 12-1 . Automatic Fault Isolation References | 626 |
| Table 12-2 . TAM Tests versus Test Connectors. | 627 |
| Table 12-3 . W1 Power-Cable Connections. | 640 |
| Table 12-4 . Automatic Fault Isolation References | 641 |
| Table 13-1 . CLIPs Available for HP 8560E and 8560EC Spectrum Analyzers. | 655 |

1 **General Information**

Introduction

This *HP 8560E and 8560EC Spectrum Analyzer Service Guide* contains information required to adjust and service the HP 8560E and 8560EC to the assembly level.

| | |
|---|---------|
| How to Use this Guide | page 25 |
| Differences between HP 8560 EC-series and E-series Spectrum Analyzers | page 26 |
| Instrument Variations | page 27 |
| Serial Number and Repair Information..... | page 29 |
| HP 85629B Test and Adjustment Module | page 31 |
| Service Kit | page 32 |
| Recommended Test Equipment..... | page 33 |
| Electrostatic Discharge..... | page 33 |
| Returning Instrument for Service..... | page 43 |

How to Use this Guide

Chapters 1 through 5 contain adjustments and parts information that can be used to help you fix problems.

Chapter 6, “General Troubleshooting”, can be used to isolate the location of a problem to a board or to a functional area in the spectrum analyzer.

Chapters 7 through 13, which cover functional areas, can then be used to help you localize the problem further.

Conventions followed in this guide:

| | |
|-------------|---|
| Screen Text | This font indicates text displayed on the screen |
| Key | This font indicates a softkey or a front panel key |
| HP 8560E/EC | This term is used to refer to both HP 8560 E-series and HP 8560 EC-series instruments |

Documentation Outline

HP 8560 E-Series Spectrum Analyzer Calibration Guide and HP 8560 EC-Series Calibration Guide

- Tells you how to run verification software.
- Tells you what your spectrum analyzer’s specifications are.
- Tells you how to test your spectrum analyzer.

HP 8560 E-Series and EC-Series User’s Guide

- Tells you how to make measurements with your spectrum analyzer.
- Tells you how to install your spectrum analyzer.
- Tells you how to program your spectrum analyzer.

HP 8560 E-Series and EC-Series Spectrum Analyzer Quick Reference Guide

- Provides an abbreviated version of the *HP 8560 E-Series and EC-Series Spectrum Analyzer’s User’s Guide*.
- Provides you with a listing of all remote programming commands.

HP 8560 E-Series Spectrum Analyzer Component Level Information

- Provides schematics, component location diagrams, and parts lists for the instrument.

Differences between HP 8560 EC-Series and E-Series Spectrum Analyzers

| Features | HP 8560 EC-Series | HP 8560 E-Series |
|---|---|--|
| Display | <ul style="list-style-type: none"> — LCD display — color — display not adjustable — backlight bulbs are replaceable (replace both bulbs when display is dim) — requires A17 LCD driver board | <ul style="list-style-type: none"> — CRT display — monochrome — display adjustable for intensity, focus, and quadrature — requires high voltage module (HVM), which is located in the A6 power supply — requires A17 CRT driver board |
| Fast ADC sweep times (FADC) enables sweep times of 30 ms to 50 μ s | <ul style="list-style-type: none"> — FADC is standard — FADC circuitry integrated into A2 controller board | <ul style="list-style-type: none"> — FADC is available as an option (Option 007) — separate A16 FADC board required |
| VGA port | <ul style="list-style-type: none"> — located on rear panel — always active — does not require user interface | Not available |

In all other operational respects the EC-series and E-series are identical. Unless otherwise noted, the information in this manual applies to all 8560EC and 8560E instruments.

NOTE

FADC is a standard feature, and not an option in HP 8560 EC-series instruments. However, it is still necessary that option “007” be in the instrument’s serial ID string. For this reason, if you press the **Datecode & Options** key, the message shown on the display will indicate that option 007 is present. In addition, a statement on the rear panel of the instrument reads “Option 007 must be in serial ID string”.

NOTE

Diagrams that illustrate features common to E-series and EC-series instruments are shown with E-series instruments. Where there are differences between E-series and EC-series features, separate diagrams are provided for E-series and for EC-series instruments.

Instrument Variations

There are options available to the HP 8560E/EC spectrum analyzer. The following table lists these options and identifies the assemblies which are unique to them.

Table 1-1 Instrument Variations

| Option | Added | Deleted |
|--|--|---|
| HP 8560E/EC Option 001 (2nd IF Output) | W19 Cable Assembly Rear Panel J10 | |
| HP 8560E/EC Option 002 (Tracking Generator) | A10 Tracking Generator Assembly Front Dress Panel (Opt 002) W14 Cable Assembly W16 Cable Assembly W43 Cable Assembly W46 Cable Assembly W47 Cable Assembly W48 Cable Assembly Rear panel J11 Front-panel J6 | Front Dress Panel (Standard) W36 Cable Assembly W42 Cable Assembly Front-panel J3 |
| HP 8560E/EC Option 005 (Add Alternate Sweep Output) | W58 Cable Assembly | |
| HP 8560E Option 007 (Fast ADC) -Fast ADC is available as an option for 8560E instruments -Fast ADC is a standard feature of 8560EC instruments and does not require additional assemblies | A16 Fast ADC Assembly A3 Interface Assembly (Opt 007) W20 Cable Assembly (Opt 007) W59 Cable Assembly | A3 Interface Assembly (Standard) W20 Cable Assembly (Standard) |
| HP 8560E/EC Option 008 (SIG ID) | A15 RF Assembly (Opt 008) | A15 RF Assembly (Std) |

Table 1-1 Instrument Variations

| Option | Added | Deleted |
|--|---------------------------|---|
| HP 8560E/EC Option 103 (Delete OCXO) | A15 RF Assembly (Opt 103) | W49 Cable Assembly W50 Cable Assembly A15 RF Assembly (Std) A21 OCXO |
| HP 8560E/EC Option 104 (Delete HP 85620A) | | HP 85620A Mass Memory Module |
| HP 8560E/EC Option 327 (Delete IF Input and Video Output) | | W24 Cable Assembly W36 Cable Assembly Front-panel J3 Rear-panel J4 |

Serial Numbers and Repair Information

Hewlett-Packard makes frequent improvements to its products to enhance performance, usability, or reliability. Hewlett-Packard service personnel have access to complete records of design changes to each type of equipment, based on the equipment serial number. Whenever you contact Hewlett-Packard about a product, have the complete serial number available to ensure obtaining the most complete and accurate information possible.

The serial number label is usually attached to the rear of the product. The serial number has two parts: the prefix (two letters and the first four numbers), and the suffix (the last four numbers).

Figure 1-1 Serial Number Label Example

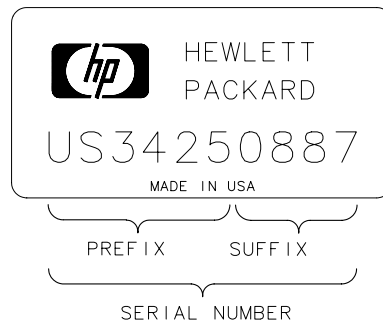

sz155e

The two letters identify the country in which the unit was manufactured. The four numbers of the prefix are a code identifying the date of the last major design change incorporated in your Hewlett-Packard product. The four-digit suffix is a sequential number and, coupled with the prefix, provides a unique identification for each unit produced. Whenever you list the serial number or refer to it in obtaining information about your Hewlett-Packard product, be sure to use the complete number, including the full prefix and the suffix.

Units which were produced before the serial number format was changed may also be covered by this documentation. On earlier serial number labels, the prefix consists of the first four numbers and a single letter. The suffix is a five-digit sequential number.

Figure 1-2 **Earlier Serial Number Label Example**



sz156e

It is important that you realize that the new serial number format (US00000000) is always considered "above" the earlier format (0000A00000) when you encounter change information such as "...serial prefix 3425A and above" or "...serial number 3425A00564 and above."

HP 8529B Test and Adjustment Module

When attached to the spectrum analyzer rear panel, the HP 85629B Test and Adjustment Module (TAM) provides diagnostic functions for the HP 8560E/EC. Because the TAM connects directly to the spectrum analyzer internal data and address bus, it controls the spectrum analyzer hardware directly. It would be impossible to control the hardware to the same extent either from the spectrum analyzer front panel or over the HP-IB.

The TAM measures voltages at key points in the circuitry and flags a failure whenever the voltage falls outside the limits. The TAM locates the failure to a small functional area which can be examined manually.

Service Kit

The Service Kit (HP part number 08562-60021) contains service tools required to repair the instrument. Refer to [Table 1-2](#) for a list of items in the service kit.

Table 1-2 **Service Kit Contents**

| Description | Quantity | HP Part Number |
|------------------------------|-----------------|-----------------------|
| Cable Puller | 1 | 5021-6773 |
| PC Board Prop | 1 | 5021-7459 |
| Line Filter Assembly | 1 | 5061-9032 |
| Line Switch Cable | 1 | 5062-0728 |
| Extender Cable | 1 | 5062-0737 |
| BNC to SMB (snap-on) Cable | 2 | 85680-60093 |
| Connector Extractor Tool Kit | 1 | 8710-1791 |

Recommended Test Equipment

Equipment required for operation verification, performance tests, adjustments, troubleshooting, and the Test and Adjustment Module is listed in [Table 1-3 on page 34](#). Other equipment may be substituted if it meets or exceeds the critical specifications listed in the table. Refer to the *HP 8560 E-Series and EC-Series Spectrum Analyzer Calibration Guide* for the performance tests.

Table 1-3 Recommended Test Equipment

| Instrument | Critical Specifications for Equipment Substitution | Recommended Model | Use |
|--|--|--|---------------|
| Sources | | | |
| Synthesized sweeper (two required) | Frequency range: 10 MHz to 12.0 GHz Frequency accuracy (CW): 1×10^{-9} /day Leveling modes: Internal & External Modulation modes: AM & Pulse Power level range: -80 to +16 dBm | HP 8340A/B* HP 83630A Opt 001, 008 | P,A,T, M,V |
| Synthesizer/ level generator | Frequency range: 200 Hz to 80 MHz Frequency accuracy: 1×10^{-7} /month Flatness: ± 0.15 dB Attenuator accuracy: $< \pm 0.09$ dB External 10 MHz reference input Frequency resolution: 1 Hz | HP 3335A*, [†] | P,A,T, M,V |
| Synthesized signal generator | Frequency range: 100 kHz to 2.5 GHz Residual SSB phase noise at 1 GHz: <-73 dBc/Hz at 10 Hz offset <-107 dBc/Hz at 1 kHz offset <-124 dBc/Hz at 10 kHz offset <-124 dBc/Hz at 100 kHz offset | HP 8663A | P,V |
| Pulse/function generator | Frequency range: 10 kHz to 50 MHz Pulse width: 200 ns Output amplitude: 5 V peak-to-peak Functions: pulse & triangle Pulse rise time: <100 ns TTL sync output | HP 8116A | P,A |
| AM/FM signal generator | Frequency range: 1 MHz to 200 MHz Frequency modulation mode Modulation oscillator frequency: 1 kHz FM peak deviation: 5 kHz | HP 8640B HP 8642A | A |
| <p>* Part of microwave workstation;[†]If an HP 3335A is not available, see chapter 2a for performance tests using alternate equipment. P = performance tests; A = adjustments; M = test & adjustment module T = troubleshooting; V = operation verification</p> | | | |

Table 1-3 Recommended Test Equipment

| Instrument | Critical Specifications for Equipment Substitution | Recommended Model | Use |
|--|---|-------------------------|---------------|
| Counters | | | |
| Frequency standard | Output frequency: 10 MHz Accuracy: $<1 \times 10^{-10}$ | HP 5061B | P,A |
| Microwave frequency counter | Frequency range: 9 MHz to 26.5 GHz Timebase accuracy (aging): $<5 \times 10^{-10}$ /day External frequency reference input | HP 5343A* Option 001 | P,A,M,V |
| Universal counter | Modes: TI A→B, frequency count Time interval measurement range: 100 ns to 120 s Frequency count range: 400 Hz to 11 MHz Frequency resolution: 1 mHz Timebase accuracy (aging): $<3 \times 10^{-7}$ /month External 10 MHz reference input | HP 5334A/B | P |
| Receivers | | | |
| Spectrum analyzer (for HP 8560E/EC Option 002) | Frequency range: 300 kHz to 7 GHz Relative amplitude accuracy: 300 kHz to 2.7 GHz: $<\pm 1.8$ dB 300 kHz to 7 GHz: $<\pm 4.0$ dB Absolute amplitude accuracy: 3.9 GHz to 6.9 GHz: $<\pm 2.7$ dB Frequency accuracy: $<\pm 10$ kHz at 7 GHz | HP 8566B* | P,A,T |
| Spectrum analyzer | Frequency range: 300 kHz to 7 GHz Amplitude range: -70 dBm to +20 dBm | HP 8566B* | A,T |
| Measuring receiver | Compatible w/power sensors dB relative mode Resolution: 0.01 dB Reference accuracy: $<\pm 1.2\%$ | HP 8902A* | P,A,T, M,V |

* Part of microwave workstation

P = performance tests; A = adjustments; M = test & adjustment module;

T = troubleshooting;

V = operation verification

Table 1-3 Recommended Test Equipment

| Instrument | Critical Specifications for Equipment Substitution | Recommended Model | Use |
|---|--|--|---------------|
| Sensors | | | |
| Power sensor | Frequency range: 10 MHz to 12 GHz Maximum SWR: 1.40 (10 to 30 MHz) 1.18 (30 to 50 MHz) 1.10 (50 MHz to 2 GHz) 1.18 (2 to 12.4 GHz) | HP 8481A* | P,A,T, M,V |
| Power sensor | Frequency range: 250 MHz to 350 MHz Power range: 100 nW to 10 μ W Maximum SWR: 1.15 (250 to 350 MHz) | HP 8481D | P,A |
| Power sensor | Frequency range: 100 kHz to 2.9 GHz Maximum SWR: 1.1 (1 MHz to 2.0 GHz) 1.30 (2.0 GHz to 2.9 GHz) | HP 8482A* | P,A,T, M,V |
| Other Equipment | | | |
| Controller | Required to run operation verification software and adjustment/diagnostic software (HP 8564E/HP 8565E) | HP 9816A, HP 9836A/C, HP 310, 320 HP 332, 360 | V |
| Oscilloscope | Bandwidth (3 dB): dc to 100 MHz Two channels Minimum vertical deflection factor: ≤ 5 mV/div Minimum timebase setting: < 100 ns Digitizing display with time cursors Delta-t cursor accuracy in 500 ns/Div: < 0.1 μ s | HP 54501A* | P,A,T |
| Amplifier | Frequency range: HP 8560E/EC, 2.0 to 2.9 GHz HP 8561E, 2.0 to 6.5 GHz HP 8563E, 2.0 to 8.0 GHz HP 8564E, 2.0 to 8.0 GHz HP 8565E, 2.0 to 8.0 GHz Minimum output power (leveled) 2.0 to 8.0 GHz: +16 dBm | HP 11975A | P |
| * Part of microwave workstation P = performance tests; A = adjustments; M = test & adjustment module; T = troubleshooting; V = operation verification | | | |

Table 1-3 Recommended Test Equipment

| Instrument | Critical Specifications for Equipment Substitution | Recommended Model | Use |
|-----------------------|---|-------------------|-----|
| Power supply | Output SWR (leveled): <1.7 Output voltage: ≥ 24 Vdc Output voltage accuracy: $< \pm 0.2$ V | HP 6114A | A |
| Signature multimeter | Clock frequency >10 MHz Time interval function | HP 5005A/B | T |
| Digital voltmeter | Range: -15 Vdc to +120 Vdc Accuracy: $< \pm 1$ mV on 10 V range Input impedance: ≥ 1 M Ω | HP 3456A* | A,T |
| Probes | | | |
| DVM test leads | ≥ 36 inches, alligator clips, probe tips | HP 34118A | A,T |
| High-frequency probe | No substitute | HP 85024A | T |
| High-voltage probe | Voltage division ratio: 1000:1 | HP 34111A | T |
| Accessories | | | |
| Directional bridge | Frequency range: 1 to 80 MHz Coupling: 6 dB (nominal) Maximum coupling deviation: <1 dB (nominal) Directivity: 40 dB minimum Impedance: 50 Ω (nominal) | HP 8721A | P |
| Directional coupler | Frequency range: 2.0 to 6.5 GHz Coupling: 16.0 dB (nominal) Maximum coupling deviation: ± 1 dB (nominal) Directivity: 14 dB minimum Flatness: 0.75 dB maximum VSWR: <1.45 Insertion loss: <1.3 dB | 0955-0098 | P |
| 10 dB step attenuator | Attenuation range: 30 dB Frequency range: dc to 80 MHz Connectors: BNC(f) | HP 355D | P,V |
| 1 dB step attenuator | Attenuation range: 12 dB Frequency range: dc to 80 MHz | HP 355C | P,V |

* Part of microwave workstation

V = operation verification

P = performance tests; A = adjustments; M = test & adjustment module; T = troubleshooting;

Table 1-3 Recommended Test Equipment

| Instrument | Critical Specifications for Equipment Substitution | Recommended Model | Use |
|---|---|------------------------|---------|
| 20 dB fixed attenuator | Connectors: BNC(f) Frequency range: dc to 18 GHz Attenuation accuracy: ± 1 dB Maximum SWR: 1.2 (dc to 2.9 GHz) | HP 8491B Option 020 | P,V |
| 10 dB fixed attenuator | Frequency range: dc to 18 GHz Attenuation accuracy: ± 0.6 dB Maximum SWR: 1.2 (dc to 2.9 GHz) | HP 8491B Option 010 | P,V |
| Reference attenuator | supplied with HP 8481D | HP 11708A | P,A |
| Termination | Frequency range: dc to 2.9 GHz Impedance: 50 Ω Maximum SWR: <math>< 1.10</math> Connector: Type N(m) | HP 908A | P,M,V |
| Low-pass filter | Cutoff frequency: 50 MHz Rejection at 65 MHz: >40 dB Rejection at 75 MHz: >60 dB | 0955-0306 | P,M,V |
| Power splitter | Frequency range: 1 kHz to 12 GHz Insertion loss: 6 dB (nominal) Output tracking: <math>< 0.25</math> dB Equivalent output SWR: <math>< 1.22</math> | HP 11667A | P,A,M,V |
| Service accessory kit | No substitute | 08562-60021 | A,T |
| Tuning tool | No substitute | 8710-1010 | A |
| Cables | | | |
| Test cable | Connectors: BNC (m)-to-SMB (f) Length: ≥ 61 cm (24 in.) | 85680-60093 | A,M |
| Cable, RG-214/U | Connectors: Type N (m) Length: ≥ 91 cm (36 in.) | HP 11500A | P,V |
| Cable | Connectors: SMA (m) Length: 24 to 36 inches | 8120-1578 | P |
| * Part of microwave workstation P = performance tests; A = adjustments; M = test & adjustment module; T = troubleshooting; V = operation verification | | | |

Table 1-3 Recommended Test Equipment

| Instrument | Critical Specifications for Equipment Substitution | Recommended Model | Use |
|--|--|-------------------|---------|
| Cable, 50 Ω coaxial <i>(five required)</i> | Connectors: BNC (m) Length: \geq 122 cm (48 in.) | HP 10503A | P,A,V |
| Cable <i>(two required)</i> | Frequency range: 30 Hz to 26.5 GHz Maximum SWR: <1.4 at 26.5 GHz Maximum insertion loss: 3 dB Connectors: APC 3.5 (m), both ends Length: \geq 61 cm (24 in.) | 8120-4921 | P,A,M,V |
| Cable <i>(for HP 8564E and HP 8565E)</i> | Frequency range: 30 Hz to 50 GHz Maximum SWR: <1.55 at 50 GHz Maximum insertion loss: 5.75 dB Connectors: 2.4 mm (f) to 2.4 mm (m) Length: \geq 1 m (39 in.) | 8120-6164 | P,A,V,T |
| Cable, HP-IB <i>(eight required)</i> | Required w/operation verification software Required w/HP 85629B test & adjustment module Length: 2 m (6.6 ft.) | HP 10833B | P,A,M |
| Adapters | | | |
| Adapter | Type N(f)-to-BNC(m) | 1250-1477 | P,A |
| Adapter <i>(three required)</i> | Type N(m)-to-BNC(f) | 1250-1476 | P,A,V |
| Adapter | Type N(f)-to-BNC(f) | 1250-1474 | P,V |
| Adapter | Type N(m)-to-N(m) | 1250-1475 | P |
| Adapter | Type N(f)-to-APC 3.5(m) | 1250-1750 | A |
| Adapter <i>(two required)</i> | Type N(m)-to-APC 3.5(m) | 1250-1743 | P,M,V |
| Adapter | Type N(m)-to-APC 3.5(f) | 1250-1744 | P,V |

* Part of microwave workstation

P = performance tests; A = adjustments; M = test & adjustment module; T = troubleshooting;

V = operation verification

Table 1-3 Recommended Test Equipment

| Instrument | Critical Specifications for Equipment Substitution | Recommended Model | Use |
|---|--|-------------------|---------|
| Adapter | Type N(m)-to-BNC(m) | 1250-1473 | P |
| Adapter | Type N(m)-to-N(f) | 1250-1472 | P |
| Adapter <i>(two required)</i> | Type N(f)-to-APC 3.5(f) | 1250-1745 | P,V |
| Adapter <i>(two required)</i> | Type N(m)-to-SMA(f) | 1250-1250 | P,V |
| Adapter | Type N(f)-to-SMA(f) | 1250-1772 | P |
| Adapter | BNC(f)-to-BNC(f) | 1250-0059 | A |
| Adapter | BNC tee(f)(m)(f) | 1250-0781 | P,A,M,V |
| Adapter | BNC(f)-to-SMA(m) | 1250-1200 | P,A,V |
| Adapter | BNC(f)-to-dual banana plug | 1251-2816 | A,T |
| Adapter <i>(two required)</i> | APC 3.5(f)-to-APC 3.5(f) | 5061-5311 | P,M,V |
| Adapter <i>(two required)</i> | APC 3.5(m)-to-APC 3.5(m) | 1250-1748 | P,V |
| Adapter | 2.4 mm(f)-to-2.4 mm(f) | HP 11900B | P,A,T,V |
| Adapter | APC 3.5(f)-to-2.4 mm(f) | HP 11901B | P |
| Adapter | APC 3.5(m)-to-2.4 mm(f) | HP 11901D | P |
| Adapter | Type N(f)-to-2.4 mm(f) | HP 11903B | P,A,T,V |
| Adapter | Type N(f)-to-2.4 mm(m) | HP 11903C | P |
| <p>* Part of microwave workstation P = performance tests; A = adjustments; M = test & adjustment module; T = troubleshooting; V = operation verification</p> | | | |

Electrostatic Discharge

Electrostatic discharge (ESD) can damage or destroy electronic components. Therefore, all work performed on assemblies consisting of electronic components should be done at a static-free workstation.

Figure 1-3 is an example of a static-safe workstation using two kinds of ESD protection:

- Conductive table mat and wrist-strap combination.
- Conductive floor mat and heel-strap combination.

These methods may be used together or separately.

Figure 1-3 Example of a Static-Safe Workstation

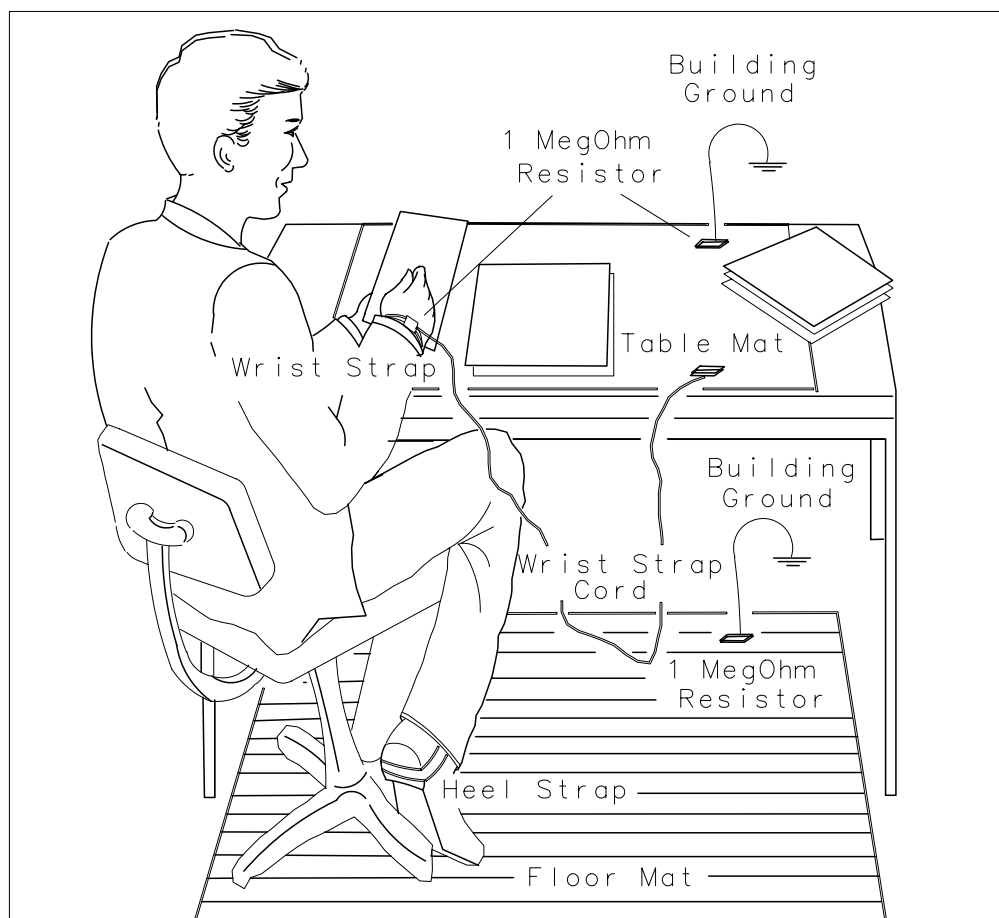

Reducing Potential for ESD Damage

The suggestions that follow may help reduce ESD damage that occurs during instrument testing and servicing:

- Before connecting any coaxial cable to a spectrum analyzer connector for the first time each day, momentarily ground the center and outer connectors of the cable.
- Personnel should be grounded with a resistor-isolated wrist strap before touching the center in of any connector and before removing any assembly from the unit.
- Be sure all instruments are properly earth-grounded to prevent build-up of static discharge.

Static-Safe Accessories

Table 1-4

Static-Safe Accessories

| HP Part Number | Description |
|----------------|---|
| 9300-0797 | Set includes: 3M static control mat 0.6 m × 1.2 m (2 ft × 4 ft) and 4.6 cm (15 ft) ground wire. (The wrist-strap and wrist-strap cord are not included. They must be ordered separately.) |
| 9300-0980 | Wrist-strap cord 1.5 m (5 ft) |
| 9300-1383 | Wrist-strap, color black, stainless steel, without cord, has four adjustable links and a 7 mm post-type connection. |
| 9300-1169 | ESD heel-strap (reusable 6 to 12 months). |

Returning Instruments for Service

Service Tag

If you are returning the instrument to Hewlett-Packard for servicing, fill in and attach a blue service tag. Service tags are supplied in the back of this chapter.

Please be as specific as possible about the nature of the problem. If you have recorded any error messages that appeared on the screen, or have completed a performance test record, or have any other specific data on the performance of the spectrum analyzer, please send a copy of this information with the unit.

Original Packaging

Before shipping, pack the unit in the original factory packaging materials if they are available. If the original materials are unavailable, identical packaging materials may be acquired through any Hewlett-Packard Sales and Service Office. Descriptions of the packaging materials are listed in [Figure 1-4 on page 45](#).

Other Packaging

CAUTION

Spectrum analyzer damage can result from using packaging materials other than those specified. Never use styrene pellets in any shape as packaging materials. They do not adequately cushion the equipment or prevent it from shifting in the carton. They cause equipment damage by generating static electricity and by lodging in the spectrum analyzer fan.

Repackage the spectrum analyzer in the original packaging materials or with commercially available materials described in steps 4 and 5, below.

1. Attach a completed service tag to the instrument.
2. Install the front-panel cover on the instrument.
3. Wrap the instrument in antistatic plastic to reduce the possibility of damage caused by electrostatic discharge.

4. Use the original materials or a strong shipping container that is double-walled, corrugated cardboard carton with 159 kg (350 lb) bursting strength. The carton must be both large enough and strong enough to accommodate the spectrum analyzer and allows at least 3 to 4 inches on all sides of the spectrum analyzer for packing material.
5. Surround the equipment with at least 3 to 4 inches of packing material, or enough to prevent the equipment from moving in the carton. If packing foam is unavailable, the best alternative is SD-240 Air Cap™ from Sealed Air Corporation (Commerce, CA 90001). Air Cap looks like a plastic sheet covered with 1-1/4 inch air-filled bubbles. Use the pink-colored Air Cap to reduce static electricity. Wrap the equipment several times in this material to both protect the equipment and prevent it from moving in the carton.
6. Seal the shipping container securely with strong nylon adhesive tape.
7. Mark the shipping container "FRAGILE, HANDLE WITH CARE" to assure careful handling.
8. Retain copies of all shipping papers.

Figure 1-4 HP 8560E/EC Shipping Container and Cushioning Materials

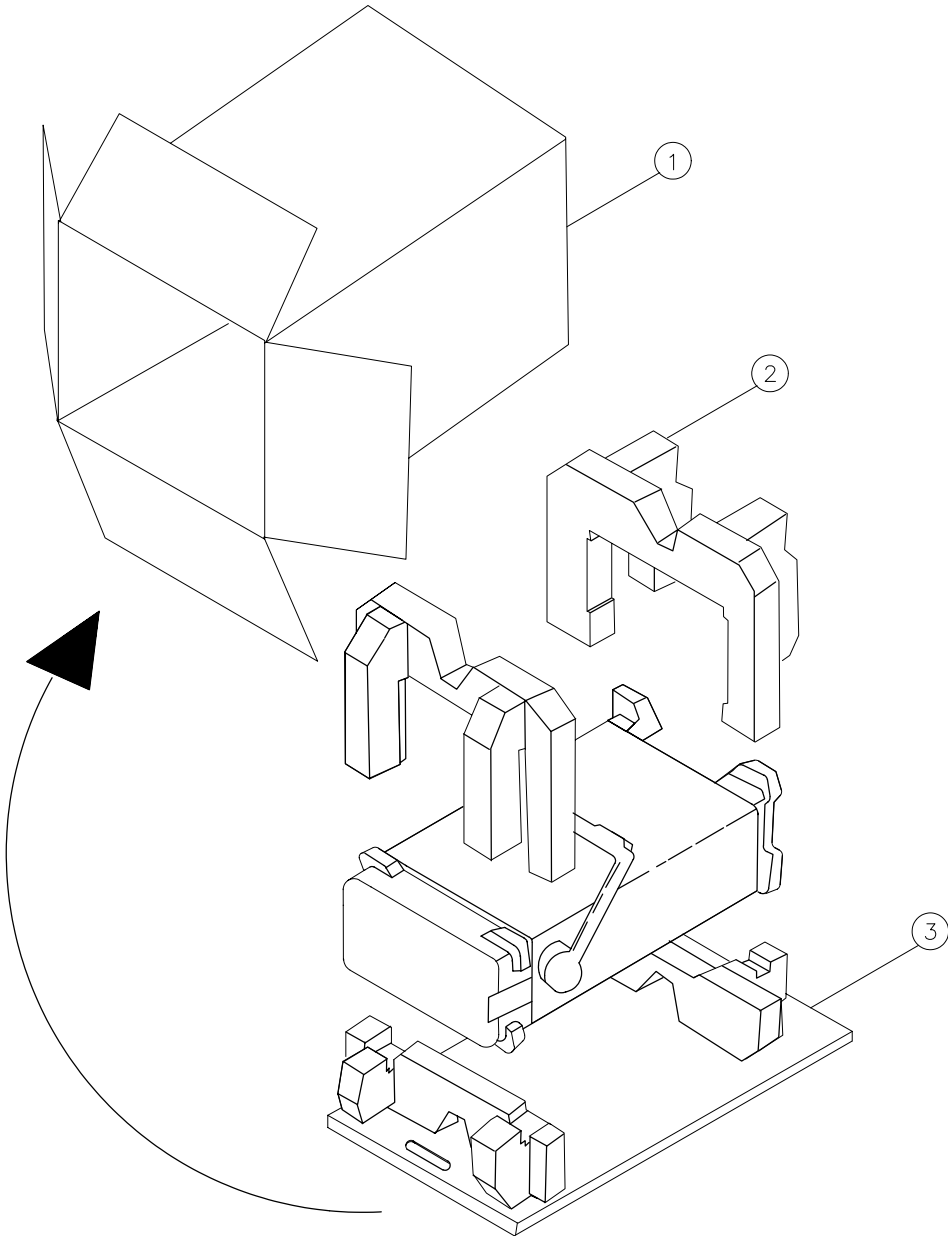

FORMAT69

Table 1-5

Static-Safe Accessories

| Item | Description | HP Part Number |
|------|-------------|----------------|
| 1 | 9211-5636 | Outer Carton |
| 2 | 08590-80013 | Pads (2) |
| 3 | 08590-80014 | Bottom Tray |

Sales and Service Offices

Hewlett-Packard has sales and service offices around the world providing complete support for Hewlett-Packard products. To obtain servicing information, or to order replacement parts, contact the nearest Hewlett-Packard Sales and Service Office listed in [Table 1-6 on page 47](#). In any correspondence, be sure to include the pertinent information about model numbers, serial numbers, and assembly part numbers.

NOTE

Within the USA, a toll-free phone number is available for ordering replacement parts. Refer to the section entitled, "Ordering Information" in Chapter 4, "Replaceable Parts," for the phone number and more information.

Table 1-6 Hewlett-Packard Sales and Service Offices

| UNITED STATES | | |
|--|---|---|
| Instrument Support Center Hewlett-Packard Company (800) 403-0801 | | |
| EUROPEAN FIELD OPERATIONS | | |
| Headquarters Hewlett-Packard S.A. 150, Route du Nant-d'Avril 1217 Meyrin 2/ Geneva Switzerland (41 22) 780.8111 | France Hewlett-Packard France 1 Avenue Du Canada Zone D'Activite De Courtaboeuf F-91947 Les Ulis Cedex France (33 1) 69 82 60 60 | Germany Hewlett-Packard GmbH Hewlett-Packard Strasse 61352 Bad Homburg v.d.H Germany (49 6172) 16-0 |
| Great Britain Hewlett-Packard Ltd. Eskdale Road, Winnersh Triangle Wokingham, Berkshire RG41 5DZ England (44 118) 9696622 | | |
| INTERCON FIELD OPERATIONS | | |
| Headquarters Hewlett-Packard Company 3495 Deer Creek Rd. Palo Alto, CA 94304-1316 USA (415) 857-5027 | Australia Hewlett-Packard Australia Ltd. 31-41 Joseph Street Blackburn, Victoria 3130 (61 3) 895-2895 | Canada Hewlett-Packard (Canada) Ltd. 17500 South Service Road Trans-Canada Highway Kirkland, Quebec H9J 2X8 Canada (514) 697-4232 |
| Japan Hewlett-Packard Japan, Ltd. 9-1 Takakura-Cho, Hachioji Tokyo 192, Japan (81 426) 60-2111 | Singapore Hewlett-Packard Singapore (Pte.) Ltd. 150 Beach Road #29-00 Gateway West Singapore 0718 (65) 291-9088 | Taiwan Hewlett-Packard Taiwan 8th Floor, H-P Building 337 Fu Hsing North Road Taipei, Taiwan (886 2) 712-0404 |
| China China Hewlett-Packard Co. 38 Bei San Huan X1 Road Shuang Yu Shu Hai Dian District Beijing, China (86 1) 256-6888 | | |

2

Adjustment Procedures

Introduction

This chapter contains information on automated and manual adjustment procedures for the HP 8560E/EC spectrum analyzer. Perform the automated procedures using the HP 85629B Tests and Adjustment Module (TAM). Never perform adjustments as routine maintenance. Adjustments should be performed after a repair or performance test failure.

| | |
|---|----------|
| Introduction..... | page 50 |
| Safety Considerations..... | page 51 |
| Which Adjustments Should Be Performed?..... | page 51 |
| Test Equipment..... | page 51 |
| Adjustable and Factory-Selected Components..... | page 51 |
| Adjustment Tools..... | page 52 |
| Instrument Service Position..... | page 52 |
| Using the TAM..... | page 57 |
| Test Equipment..... | page 51 |
| Adjustment Indicator..... | page 57 |
| 1. High Voltage Power Supply Adjustment (8560E)..... | page 60 |
| 2. Display Adjustment (8560E)..... | page 63 |
| 3. IF Bandpass Adjustment..... | page 70 |
| 4. IF Amplitude Adjustments..... | page 75 |
| 5. DC Log Amplifier Adjustments..... | page 80 |
| 6. Sampling Oscillator Adjustment..... | page 84 |
| 7. YTO Adjustment..... | page 87 |
| 8. First LO Distribution Amplifier Adjustment..... | page 91 |
| 9. Tracking Generator Power Level Adjustments (002).... | page 94 |
| 10. Frequency Response Adjustment..... | page 97 |
| 11. Calibrator Amplitude Adjustment..... | page 101 |
| 12. 10 MHz Reference Adjustment-TCXO (Option 103) . | page 103 |
| 13. Demodulator Adjustment..... | page 105 |
| 14. External Mixer Bias Adjustment..... | page 108 |
| 15. External Mixer Amplitude Adjustment..... | page 110 |
| 16. Signal ID Oscillator Adjustment (prefix<3517A)..... | page 114 |
| 17. 10 MHz Reference Adjustment-OCXO..... | page 118 |
| 18. Tracking Oscillator Adjustment (Option 002)..... | page 122 |
| 19. 16 MHz PLL Adjustment..... | page 126 |
| 20. 600 MHz Reference Adjustment (prefix> 3406A)..... | page 130 |

NOTE

Before performing any adjustments, allow the instrument to warm up for 5 minutes.

Safety Considerations

Although this instrument has been designed in accordance with international safety standards, this manual contains information, cautions, and warnings which must be followed to ensure safe operation and to prevent damage to the instrument. Service and adjustments should be performed only by qualified service personnel.

| | |
|---------|--|
| WARNING | Adjustments in this section are performed with power supplied to the instrument and protective covers removed. There are voltages at many points in the instrument which can, if contacted, cause personal injury. Be extremely careful. Adjustments should be performed only by trained service personnel. |
| WARNING | Power is still applied to this instrument with the LINE switch in the off position. Before removing or installing any assembly or printed circuit board, remove the line-power cord. |
| WARNING | Capacitors inside the instrument may still be charged, even if the instrument has been disconnected from its source of supply. |
| WARNING | Use a nonmetallic adjustment tool whenever possible. |

Which Adjustments Should Be Performed?

[Table 2-1 on page 52](#) lists the manual adjustments that should be performed when an assembly is repaired or changed. It is important to perform the adjustments in the order indicated to ensure that the instrument meets its specifications.

Test Equipment

The equipment required for the manual adjustment procedures is listed in [Table 2-1 on page 52](#), "Recommended Test Equipment." Any equipment that satisfies the critical specifications given in the table may be substituted for the preferred test equipment.

If an HP 3335A is not available for performance tests, tests using alternate test equipment are available. See [Chapter 2a, "Adjustment Procedures: HP 3335A Source not Available," on page 131](#).

Adjustable and Factory-Selected Components

[Table 2-2 on page 54](#) lists the adjustable components by reference designation and name. For each component, the table provides a description and lists the adjustment number.

Refer to [Table 2-3 on page 56](#) for a complete list of factory-selected components used in the instrument along with their functions. Factory-selected components are identified with an asterisk on the schematic diagrams.

Adjustment Tools

For adjustments requiring a nonmetallic tuning tool, use fiber tuning tool, HP part number 8170-0033.

Two different tuning tools may be necessary for IF bandpass adjustments, depending upon the type of tuning slug used in the slug-tuned inductors. If the tuning slug requires a slotted tuning tool, use HP part number 8710-1010. If the tuning slug requires a forked tuning tool, use HP part number 8710-0772.

Never try to force an adjustment control. This is especially critical when tuning variable capacitors or slug-tuned inductors. Required service accessories, with part numbers, are listed under "Service Kit" in Chapter 1.

Instrument Service Position

Refer to Chapter 3 for information on removing the spectrum analyzer cover assembly and accessing all internal assemblies.

Table 2-1 Related Adjustments

| Assembly Changed or Repaired | Perform the Following Related Adjustments in the Order Listed | Adjustment Number |
|-------------------------------------|---|--------------------------|
| A1A1 Keyboard | No related adjustment | |
| A1A2 RPG | No related adjustment | |
| A2 Controller | 16 MHz PLL Adjustment | 19 |
| | Display Adjustment (8560E only) | 2 |
| | If the old EEROM cannot be used in a new A2 or if an EEROM must be replaced, the following adjustments must be performed: | |
| | First LO Distribution Amplifier Adjustment | 8 |
| | External Mixer Amplitude Adjustment | 15 |
| A3 Interface | Frequency Response Adjustment | 10 |
| | Display Adjustment (fast zero span) (8560E only) | 2 |
| | Frequency Response Adjustment | 10 |
| A4 Log Amp/Cal Osc | Display Adjustment (fast zero span) (8560E only) | 2 |
| | Demodulator Adjustment | 13 |
| | IF Amplitude Adjustment | 4 |
| | DC Log Amplifier Adjustment | 5 |

Table 2-1 Related Adjustments

| Assembly Changed or Repaired | Perform the Following Related Adjustments in the Order Listed | Adjustment Number |
|-------------------------------------|---|--------------------------|
| A5 IF | IF Bandpass Adjustment | 3 |
| | IF Amplitude Adjustment | 4 |
| A6 Power Supply | High Voltage Power Supply Adjustment (8560E only) | 1 |
| | Display Adjustment (8560E only) | 2 |
| A6A1 HV Module | High Voltage Power Supply Adjustment (8560E only) | 1 |
| | Display Adjustment (8560E only) | 2 |
| A7 1ST LO Distribution Amplifier | First LO Distribution Amplifier Adjustment | 8 |
| | Frequency Response Adjustment (or perform the Frequency Response Performance Test in the <i>HP 8560 E-Series and EC-Series Spectrum Analyzer Calibration Guide</i> . The adjustment must be performed if the performance test fails.) | 10 |
| A8 Low Band Mixer | Frequency Response Adjustment | 10 |
| A9 Input Attenuator | Frequency Response Adjustment (or perform the Frequency Response Performance Test in the <i>HP 8560 E-Series and EC-Series Spectrum Analyzer Calibration Guide</i> . The adjustment must be performed if the performance test fails.) | 10 |
| A10 Tracking Generator | Tracking Generator Power Level Adjustment | 9 |
| A11 YTO | Frequency Response Adjustment | 10 |
| | YTO Adjustment | 7 |
| | Frequency Response Adjustment (or perform the Frequency Response Performance Test in the <i>HP 8560 E-Series and EC-Series Spectrum Analyzer Calibration Guide</i> . The adjustment must be performed if the performance test fails.) | 10 |
| A13 2nd Converter | Frequency Response Adjustment | 10 |
| A14 Frequency Control | Display Adjustment (fast zero span) | 2 |
| | YTO Adjustment | 7 |
| A15 RF | First LO Distribution Amplifier Adjustment | 8 |
| | Frequency Response Adjustment | 10 |
| | 10 MHz Reference Adjustment (Option 103) | 12 |
| | Calibrator Amplitude Adjustment | 11 |
| | External Mixer Bias Adjustment | 14 |
| | Sampling Oscillator Adjustment | 6 |
| | Signal ID Oscillator Adjustment | 16 |
| External Mixer Amplitude Adjustment | 15 | |

Table 2-1 Related Adjustments

| Assembly Changed or Repaired | Perform the Following Related Adjustments in the Order Listed | Adjustment Number |
|------------------------------|---|-------------------|
| A15U100 Sampler | Frequency Response Adjustment | 10 |
| A17 CRT Driver | Sampling Oscillator Adjustment | 6 |
| A18V1 CRT | Display Adjustment (8560E only) | 2 |
| A19 HP-IB | Display Adjustment (8560E only) | 2 |
| A21 OCXO | No related adjustment | |
| | 10 MHz Reference Adjustment (OCXO) | 17 |

Table 2-2 Adjustable Components

| Reference Designator | Adjustment Name | Adjustment Number | Description |
|----------------------|------------------|-------------------|---|
| A2R152 | 16 MHz PLL ADJ | 19 | Adjusts the free-running frequency of the 16 MHz CPU clock. |
| A2R206 | DGTL X GAIN | 2 | Adjusts the horizontal gain in the X line generator. |
| A2R209 | SWEEP OFFSET | 2 | Adjusts the beginning of the trace to the leftmost vertical graticule line in fast-analog, zero-span mode. |
| A2R215 | DGTL Y GAIN | 2 | Adjusts the vertical gain in the Y line generator. |
| A2R218 | VIDEO OFFSET | 2 | Adjusts the vertical position in fast-analog, zero-span to match the digital zero-span input. |
| A2R262 | STOP BLANK | 2 | Adjusts the blanking at the end of a vector on the display. |
| A2R263 | START BLANK | 2 | Adjusts the blanking at the start of a vector on the display. |
| A2R268 | VIDEO GAIN | 2 | Adjusts the vertical gain in fast-analog, zero-span to match with the digital zero-span input |
| A2R271 | SWEEP GAIN | 2 | Adjusts the end of the trace to the rightmost vertical-graticule line in fast-analog, zero-span mode. |
| A4C707 | FM DEMOD | 13 | Adjusts the FM demodulation for a peak response. |
| A4R445 | LIMITER PHASE | 5 | Adjusts Limiter Phase for peak response |
| A4R531 | LOG AMP TOS | 5 | Minimizes Log error near Top of Screen. |
| A4R544 | LIN FIDELITY BOW | 5 | Minimizes Linearity Fidelity error. |
| A4R826 | CAL OSC AMPTD | 4 | Sets calibration oscillator output power. (nominally -35 dBm). This power is injected into the IF during the AUTO IF ADJUST routines. |
| A5L300 | LC CTR 1 | 3 | Adjusts center frequency of first stage of LC bandwidth filter to 10.7 MHz. |
| A5L301 | LC CTR 2 | 3 | Adjusts center frequency of second stage of LC bandwidth filter to 10.7 MHz. |
| A5L700 | LC CTR 3 | 3 | Adjusts center frequency of third stage of LC bandwidth filter to 10.7 MHz. |

Table 2-2 Adjustable Components

| Reference Designator | Adjustment Name | Adjustment Number | Description |
|----------------------|-----------------|-------------------|--|
| A5L702 | LC CTR 4 | 3 | Adjusts center frequency of fourth stage of LC bandwidth filter to 10.7 MHz. |
| A5R343 | 15 DB ATT | 4 | Adjusts the attenuation of the Reference 15 dB attenuator for 15 dB between minimum and maximum attenuation. |
| A5T200 | XTAL CTR 1 | 3 | Adjusts center frequency of first stage of crystal bandwidth filter to 10.7 MHz. |
| A5T202 | XTAL CTR 2 | 3 | Adjusts center frequency of second stage of crystal bandwidth filter to 10.7 MHz. |
| A5T500 | XTAL CTR 3 | 3 | Adjusts center frequency of third stage of crystal bandwidth filter to 10.7 MHz. |
| A5T502 | XTAL CTR 4 | 3 | Adjusts center frequency of fourth stage of crystal bandwidth filter to 10.7 MHz. |
| A6R410 | HV ADJ | 1 | Adjusts the voltage between A6TP405 and A6TP401 to the voltage marked on the A6A1 High Voltage Module. |
| A10R13 | -10 dB ADJ | 9 | Offsets power level range of A10 Tracking Generator. |
| A10R18 | 0 dB ADJ | 9 | Adjusts gain of power level range of A10 Tracking Generator. |
| A10C3 | TRK OSC CTR | 20 | Centers range of the A10 Tracking Generator tracking oscillator. |
| A14R42 | 6.01 GHz | 7 | Adjusts the main coil tune driver current at a YTO frequency of 6.01 GHz (near the upper YTO frequency limit) |
| A14R76 | FM SPAN | 7 | Adjusts the FM span accuracy by affecting the sensitivity of the FM coil driver. |
| A14R93 | 3.2 GHz | 7 | Adjusts the main coil fixed driver current at a YTO frequency of 3.2 GHz (near the lower YTO frequency limit). |
| A15C100 | SMPL MATCH 1 | 6 | Transforms the sampler input impedance to 50 ohms over the 280 to 298 MHz range |
| A15C210 | VCO RANGE | 6 | Adjusts the VCO tank capacitance so that 21 V on the VCO tune line equals 298 MHz VCO frequency. |
| A15C629 | 298 MHz ADJ | 17 | Fine adjusts the 298 MHz SIG ID Oscillator (Opt. 008) frequency to optimize its performance. |
| A15U302 | 10 MHz ADJ | 12 | Adjusts frequency of the temperature compensated crystal oscillator (TCXO) to 10 MHz. |
| A15R561 | CAL AMPTD | 11 | Adjusts amplitude of the 300 MHz calibrator signal to -10.0 dBm. |
| A15R926 | EXT BIAS ZERO | 14 | Adjusts zero bias point of external mixer bias. |
| A17R4 | Z GAIN | 2 | Adjusts maximum intensity. |
| A17R11 | CUTOFF | 2 | Adjusts intensity to turn off blanked lines. |
| A17R21 | Z FOCUS | 2 | Adjusts focus for lines of different brightness. |

Table 2-2 Adjustable Components

| Reference Designator | Adjustment Name | Adjustment Number | Description |
|----------------------|-----------------|-------------------|---|
| A17R26 | X FOCUS | 2 | Adjusts focus at the left and right corners of the display. |
| A17R34 | COARSE FOCUS | 2 | Adjusts focus at the center of the display. |
| A17R55 | X GAIN | 2 | Adjusts the horizontal-deflection amplifier gain. |
| A17R57 | X POSN | 2 | Adjusts the CRT horizontal position. |
| A17R75 | Y GAIN | 2 | Adjusts the vertical-deflection amplifier gain. |
| A17R77 | Y POSN | 2 | Adjusts the CRT vertical position. |
| A17R90 | TRACE ALIGN | 2 | Adjusts the display axis rotation. |
| A17R92 | DDD | 2 | Adjusts focus of the center of the display. |
| A17R93 | ASTIG | 2 | Adjusts for the spot roundness on the CRT display. |

Table 2-3 Factory Selected Components

| Reference Designator | Adjustment Number | Basis of Selection |
|----------------------|-------------------|--|
| A5C204 | 3 | Selected to optimize center frequency of LC tank that loads the crystal. |
| A5C216 | 3 | Selected to optimize center frequency of LC tank that loads the crystal. |
| A5C326 | 3 | Selected to optimize LC pole center frequency. |
| A5C327 | 3 | Selected to optimize LC pole center frequency. |
| A5C505 | 3 | Selected to optimize center frequency of LC tank that loads the crystal. |
| A5C516 | 3 | Selected to optimize center frequency of LC tank that loads the crystal. |
| A5C717 | 3 | Selected to optimize LC pole center frequency. |
| A5C718 | 3 | Selected to optimize LC pole center frequency. |
| A15U802 | 16 | Selected to set the gain of the second IF to 12 dB. |

Using the TAM

The HP 85629B TAM can be used to perform approximately half of the HP 8560E/EC adjustment procedures. [Table 2-4 on page 58](#) lists the TAM adjustments and their corresponding manual adjustments.

The TAM adjustments do not include procedures for choosing factory-selected components. If an adjustment cannot be made and a factory-selected component must be changed, refer to the corresponding manual adjustment.

To select an adjustment, press **MODULE** to display the TAM main menu, then press **ADJUST**. Position the pointer next to the desired adjustment using either the knob or step keys. Press **EXECUTE**, then follow the instructions displayed on the screen.

Test Equipment

During the TAM adjustments, instructions for setting test equipment controls are displayed, with the exclusion of the test listed below. Test equipment for this adjustment is controlled automatically.

Test 8. Low Band Flatness

[Table 2-5 on page 58](#) lists the test equipment needed to perform each TAM adjustment. Required models must be used. Substitutions may be made for recommended models. Substitute sources must operate over the frequency ranges indicated. Recommended substitutes are listed in the Configuration Menu. If you must substitute the source with a user-defined model, the adjustments run faster using a synthesized source rather than an unsynthesized source.

NOTE

When connecting signals from the HP 8340A/B (or any microwave source) to the adjustment setup, use a high frequency test cable with minimum attenuation to 2.9 GHz. HP part number 8120-4921 is recommended for its ruggedness, repeatability, and low insertion loss.

Adjustment Indicator

To aid in making adjustments, the TAM displays an "Analog Voltmeter Display Box" along the left-hand side of the display. A horizontal line moves inside the box to represent the needle of an analog voltmeter. A digital readout appears underneath the box. Tick marks are often displayed on the inside edges of the box indicating the desired needle position. (The tick marks and needle are intensified when the needle is within this acceptable region.) During some adjustments, an arrow appears along the right edge of the box. This arrow always indicates the highest position the needle has reached. The arrow is useful when a

component must be adjusted for a peak response; if the peak is overshoot, the arrow indicates where the peak was. The component can be readjusted until the needle is at the same position as the arrow.

Table 2-4 TAM Adjustments

| TAM Adjustment | Corresponding Manual Adjustment | Adjustment Number |
|---------------------------------|--|-------------------|
| 1. IF Bandpass, LC Poles | IF Bandpass Adjustment | 3 |
| 2. IF Bandpass, Crystal Poles | IF Bandpass Adjustment | 3 |
| 3. IF Amplitude | IF Amplitude Adjustment | 4 |
| 4. Limiter Phase | DC Log Amplifier Adjustments, A4 Limiter Phase | 5 |
| 5. Linear Fidelity | DC Log Amplifier Adjustments, A4 Linear Fidelity | 5 |
| 6. Log Fidelity | DC Log Amplifier Adjustments, A4 Log Fidelity | 5 |
| 7. Sampling Oscillator | Sampling Oscillator Adjustment | 6 |
| 8. YTO | YTO Adjustment | 7 |
| 9. LO Distribution Amp | First LO Distribution Amplifier Adjustment | 8 |
| 10. Low Band Flatness | Frequency Response Adjustment | 10 |
| 11. Calibrator Amplitude | Calibrator Amplitude Adjustment | 11 |
| 12. 10 MHz Reference Oscillator | 10 MHz Reference Adjustment – TCXO (Option 103) | 12 |
| 13. External Mixer Bias * | External Mixer Bias Adjustment | 14 |
| 14. External Mixer Amplitude * | External Mixer Amplitude Adjustment | 15 |

* Adjustment excluded if the HP 8560E/EC is an Option 002.

Table 2-5 Required Test Equipment for TAM

| Adjustment | Equipment Used | Required Model | Recommended Model |
|-------------------------------|--|----------------|-------------------|
| 1. IF Bandpass, LC Poles | None | | |
| 2. IF Bandpass, Crystal Poles | None | | |
| 3. IF Amplitude | Synthesizer/Level Generator Test Cable (SMB to BNC) Manual Probe Cable | HP 3335A | 85680-60093 |
| 4. Limiter Phase | Synthesizer/Level Generator Test Cable BNC | HP 3335A | HP 10503A |
| 5. Linear Fidelity | Synthesizer/Level Generator Test Cable BNC | HP 3335A | HP 10503A |

Table 2-5 Required Test Equipment for TAM

| Adjustment | Equipment Used | Required Model | Recommended Model |
|---------------------------------|---|-----------------------|---|
| 6. Log Fidelity | Synthesizer/Level Generator Test Cable BNC | HP 3335A | HP 10503A |
| 7. Sampling Oscillator | Manual Probe Cable | | |
| 8. YTO | Frequency Counter (3 to 6.8 GHz) | | HP 5342A, HP 5343A |
| 9. LO Distribution Amplifier | Power Meter Power Sensor (3 to 6.8 GHz, 10 to 20 dBm) | | HP 8902A, HP 436A, HP 438A HP 8485A |
| 10. Low Band Flatness | Source (10 MHz to 2.9 GHz) Power Meter Power Sensor (10 MHz to 2.9 GHz) Power Splitter (10 MHz to 2.9 GHz) | | HP 8340A/B HP 8902A, HP 436A, HP438A HP 8482A, HP 8481A HP 11667B |
| 11. Calibrator Amplitude | Power Meter Power Sensor | HP 8482A, HP 8481A | HP 8902A, HP 436A, HP 438A |
| 12. 10 MHz Reference Oscillator | Frequency Counter (9 to 11 MHz) | | HP 5342A, HP 5343A |
| 13. External Mixer Bias | Manual Probe Cable | | |
| 14. External Mixer Amplitude | Power Meter Power Sensor (310.7 MHz, -25 to -35 dBm) Source (310.7 MHz, -30 dBm) | | HP 8902A, HP 436A, HP 438A HP 8481D, HP 8484A HP 8340A/B |

1. High Voltage Power Supply Adjustment (8560E only)

Assembly Adjusted

A6 power supply

Related Performance Test

There is no related performance test for this adjustment.

Description

The high voltage power supply is adjusted to the voltage marked on the A6A1 HV module. The A6A1 HV module is characterized in the factory to ensure that the display filament voltage is set to 6.0 V rms when the +110 Vdc (nominal) supply is set to the voltage marked on the HV module.

WARNING

To minimize shock hazard, use a nonmetallic adjustment tool when adjusting the A6 power supply.

WARNING

The following procedure probes voltages that, if contacted, could cause personal injury or death.

NOTE

Adjustment of the high voltage power supply should not be a routine maintenance procedure. Any adjustments should be done only if the A6 power supply, A6A1 HV module, or A18 CRT (display) is repaired or replaced.

NOTE

You must perform the display adjustments after this adjustment if either the display or HV module has been replaced.

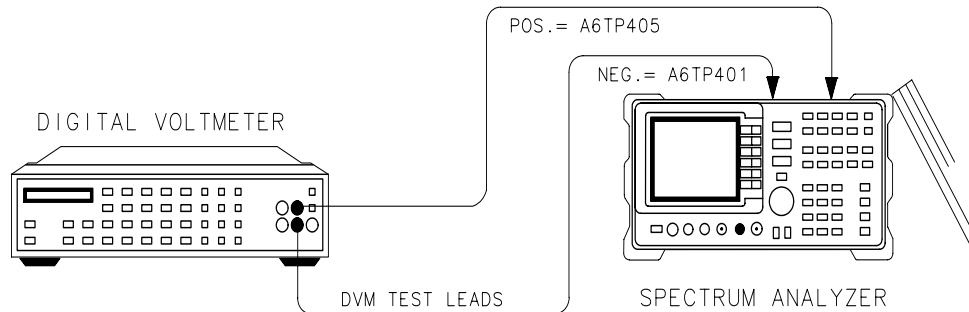
Figure 2-1 High Voltage Power Supply Adjustment Setup

SK11

Equipment

Digital multimeterHP 3456A
 DVM test leads HP 34118A

Procedure

WARNING

After disconnecting the ac power cord, allow capacitors in the high voltage supply to discharge for at least 30 seconds before removing the protective cover from the A6 power supply.

1. Press **LINE** to turn the spectrum analyzer off, disconnect the power cord, and remove the spectrum analyzer cover. Fold down the A2 controller, A3 interface, A4 log amplifier, and A5 IF assemblies. Remove the A6 power supply cover.
2. Position the HP 8560E/EC as shown in [Figure 2-1](#). Connect the negative DVM lead to A6TP401 and the positive DVM lead to A6TP405 (place the positive DVM lead on the inductor (L401) lead which is adjacent to the label that reads "U401"; a white square outlines the area on the PC board where this lead is inserted into the A6 board).
3. Set the HP 3456A controls as follows:

| | |
|----------------|------------|
| Function | DC VOLTS |
| Range | 1000 VOLTS |
4. Reconnect the power cord to the spectrum analyzer and press **LINE** to turn the spectrum analyzer on.
5. Record the voltage marked on the A6A1 HV module.

1. High Voltage Power Supply Adjustment (8560E only)

Voltage marked on A6A1 HV Module = Opt..... Vdc

6. Adjust A6R410 HV ADJ for a voltage equal to the voltage recorded in step 5.
7. Press **LINE** to turn the spectrum analyzer off and disconnect the power cord. Wait at least 30 seconds for the high voltage power supply capacitors to discharge.
8. Disconnect the DVM test leads from A6TP401 and A6TP405. Reinstall the power supply cover.

2. Display Adjustment (8560E only)

Assembly Adjusted

A2 controller A17 CRT driver

Related Performance Test

Sweep Time Accuracy (sweep times <30 ms)

Description

Coarse adjustment of the deflection amplifiers, Z-axis amplifiers, and line generators is done using the CRT adjust pattern. Fine adjustments use the graticule. The fast zero-span amplitude adjustments correct for differences between analog and digital display modes. The displayed sweep time accuracy is adjusted in fast zero-span sweep adjustments for non-Option 007 spectrum analyzers.

Figure 2-2 Display Adjustment Setup

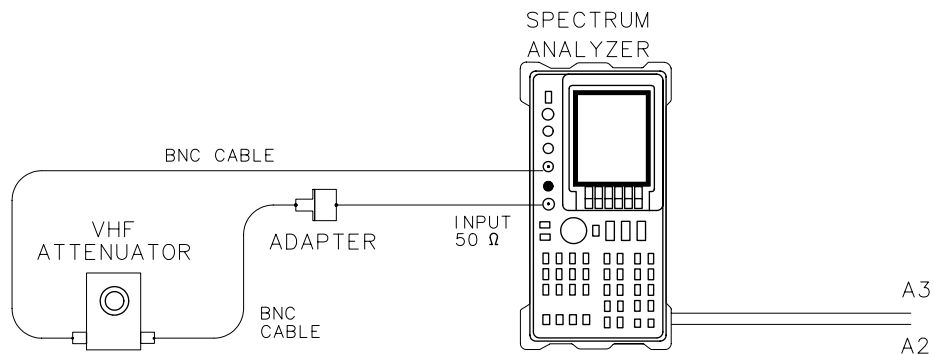

SK12

Equipment

10 dB VHF step attenuator routines..... HP 355D
Photometer/radiometer routines TEK J16-TV

Adapters

Type N (m) to BNC (f) 1250-1476

Cables

BNC, 122 cm (2 required)HP 10503A

Procedure

1. Press **LINE** to turn the spectrum analyzer off. Remove the spectrum analyzer cover and fold out the A2 Controller and A3 Interface assemblies as illustrated in [Figure 2-2 on page 63](#). Connect the CAL OUTPUT to the INPUT. Adjustment locations are shown on the CRT neck for A17 adjustments and in [Figure 2-4 on page 67](#) for the A2 adjustments.

Preliminary Adjustments

2. Set A17R55 X GAIN, A17R75 Y GAIN, A17R92 DDD, A17R93 ASTIG, A2R206 DGTL X GAIN, A2R215 DGTL Y GAIN, A2R262 STOP BLANK, and A2R263 START BLANK to midrange. Also set the rear panel X POSN, Y POSN, and TRACE ALIGN to midrange.
3. Set A17R21 Z FOCUS, A17R26 X FOCUS, and A17R11 CUTOFF fully counterclockwise.
4. Set A17R4 Z GAIN fully clockwise.
5. Turn the spectrum analyzer on and allow it to warm up for at least 3 minutes. Adjust A17R11 CUTOFF until the display is visible and A17R34 COARSE FOCUS for best possible focus.

Cutoff Adjustment

6. Press **PRESET, DISPLAY, INTENSITY, 255, ENTER, STORE INTENSITY, MORE 1 of 2, FOCUS, 127, ENTER, STORE FOCUS**, then **GRAT OFF**. Adjust A17R11 CUTOFF until the line between the bottom of trace A and the annunciators at the bottom of the display just disappears.

Deflection Adjustments

7. Press **GRAT ON, MORE 2 of 2, INTENSITY, 80 ENTER, STORE INTENSITY, CAL, MORE 1 of 2, and CRT ADJ PATTERN**. Fold up the A3 Interface assembly.
8. Refer to [Figure 2-3 on page 66](#) for locating the lines used for adjusting DGTL X GAIN and DGTL Y GAIN. Each of these lines is actually two lines adjusted for coincidence. The two lines will form an "X" if they are not adjusted properly.
9. Adjust A2R206 DGTL X GAIN until the two vertical lines near the left edge of the display appear to be one single line.
10. Adjust A2R215 DGTL Y GAIN until the two horizontal lines near the top edge of the display appear to be one single line.

11. Adjust A2R262 STOP BLANK and A2R263 START BLANK for the sharpest corners of the outer box in the test pattern. The intensity of the corners should be the same as the middle of the lines between the corners.
12. Adjust the rear panel TRACE ALIGN until the leftmost line of the test pattern is parallel with the CRT bezel. See [Figure 2-3 on page 66](#).
13. Adjust the rear panel X POSN and A17R55 X GAIN until the leftmost "@" characters and the softkey labels appear just inside the left and right edges of the CRT bezel.
14. Adjust the rear panel Y POSN and A17R75 Y GAIN until the softkey labels align with their appropriate softkeys.
15. Press **PRESET**. If necessary, readjust STOP BLANK and START BLANK for the best-looking intersection of the graticule lines. This will be most noticeable along the center vertical and horizontal graticule lines.

Intensity Adjustments

16. Press **AMPLITUDE** then set the REF LVL to -70 dB and the LOG dB/DIV to 1. This should almost completely fill the screen with the noise floor. Press **SGL SWP**. Adjust A17R4 Z GAIN until the intensity at the center of the screen is 15 NITs, as indicated by the TEK J16-TV Photometer/Radiometer.
17. Press **CAL**, **MORE 1 of 2**, and **CRT ADJ PATTERN**. Locate the dot just under the HP logo. Adjust A17R93 ASTIG for the smallest round dot possible.

Adjustment Procedures
2. Display Adjustment (8560E only)

Figure 2-3 CRT Adjust Pattern

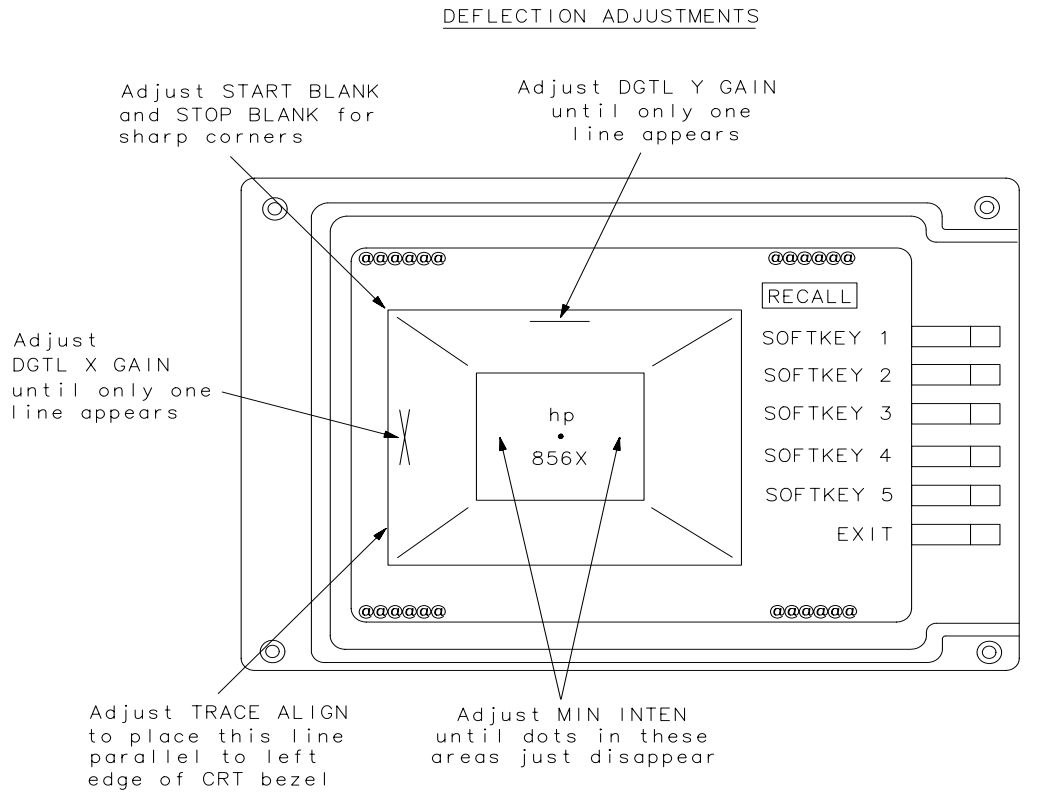

SK13

Figure 2-4 A2 Display Adjustment Locations

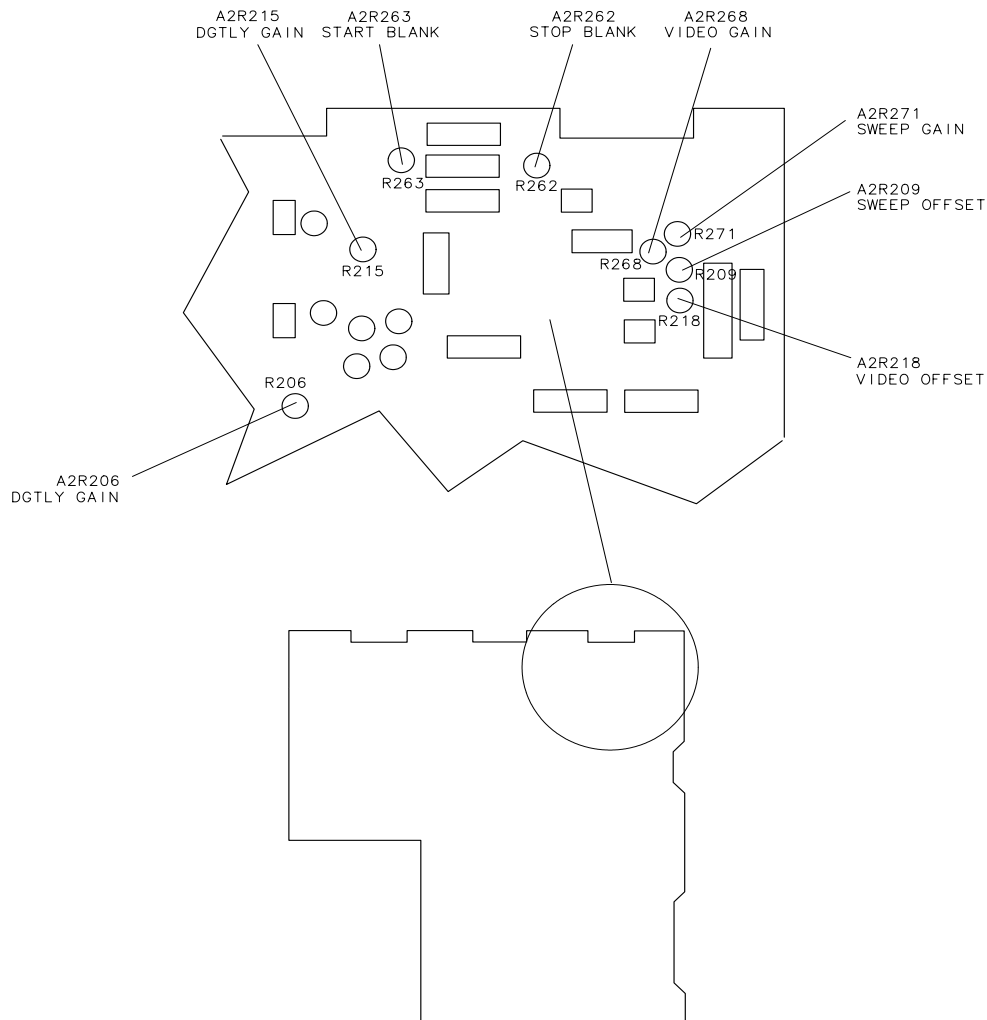

SK 14

18. Adjust A17R34 COARSE FOCUS and A17R92 DDD for the best focus of the characters at the center of the screen.
19. Adjust A17R21 Z FOCUS for the best focus of the outside box of the test pattern.
20. Adjust A17R26 X FOCUS for best focus of the "@" characters at the corners of the test pattern.
21. Repeat steps 17 through 20 to obtain the best overall focus quality.

Fast Zero Span Adjustments

NOTE

The following adjustments apply only to analyzers not equipped with Option 007, fast digitized time domain sweeps.

22. Set A2R209 SWEEP OFFSET, A2R218 VIDEO OFFSET, A2R268 VIDEO GAIN and A2R271 SWEEP GAIN to midrange. Adjustment locations are shown in [Figure 2-4 on page 67](#) for these A2 adjustments.

23. Set the HP 355D attenuator to provide 30 dB attenuation.

24. Press **PRESET** on the spectrum analyzer, and connect the equipment as shown in [Figure 2-2 on page 63](#). Set the HP 8560E/EC controls as follows:

| | |
|------------------------|---------|
| Center frequency | 300 MHz |
| Span | 0 Hz |
| Reference level | -40 dBm |
| Resolution BW | 1 kHz |
| Video BW | 300 Hz |
| Sweep time | 50 ms |

25. Press **MKR**, **MKR->**, and **MARKER-> REF LVL**. If the marker is not at the top graticule, press **MARKER-> REF LVL** again.

26. Press **SAVE**, **SAVE STATE**, and **STATE 0**.

27. Set the sweep time to 10 ms.

28. Press **SAVE**, **SAVE STATE**, and **STATE 1**.

29. Adjust A2R209 SWEEP OFFSET to place the beginning of the trace at the leftmost vertical graticule line.

30. Adjust A2R271 SWEEP GAIN to place the end of the trace at the tenth vertical graticule line (one division from the right edge of the graticule).

31. Press **AMPLITUDE** and press the \Downarrow key 7 times.

32. Press **SAVE**, **SAVE STATE**, and **STATE 2**.

33. Set the sweep time to 50 ms. Press **SAVE**, **SAVE STATE**, and **STATE 3**.

34. Press **RECALL**, **RECALL STATE**, and **STATE 1**.

35. Switch between **STATE 1** and **STATE 2**. Adjusting A2R268 and A2R218 so that in **STATE 1** the trace is lined up with the top graticule and in **STATE 2** the trace is lined up with the eighth graticule (from the top line). Repeat until they align to within ± 0.2 divisions.

36. Adjust A2R209 and A2R271 until the start of sweep is aligned to the leftmost vertical graticule line and the stop sweep is aligned with the right most vertical graticule line.
37. Press **STATE 2** and **STATE 3**. The two traces should be aligned within ± 0.1 divisions.
38. Press **STATE 0** and **STATE 1**. The two traces should be aligned within ± 0.1 divisions.

3. IF Bandpass Adjustment

Assembly Adjusted

A5 IF assembly

Related Performance Test

Resolution Bandwidth Accuracy and Selectivity

Description

The center frequency of each IF bandpass filter pole is adjusted by DAC-controlled varactor diodes and an inductor (for the LC poles) or a transformer (for the crystal poles). The inductors and transformers are for coarse tuning and the varactors are for fine tuning by the microprocessor. The inductors and transformers are adjusted such that the varactor diodes are biased near the middle of their capacitance range. The varactor diode bias is measured with the DVM.

NOTE This procedure is not a routine adjustment. It should be performed only if repairs to the A5 IF assembly are made. If the entire A5 IF assembly is replaced, the assembly arrives pre-adjusted from the factory and requires no further adjustment.

Figure 2-5 IF Bandpass Adjustment Setup

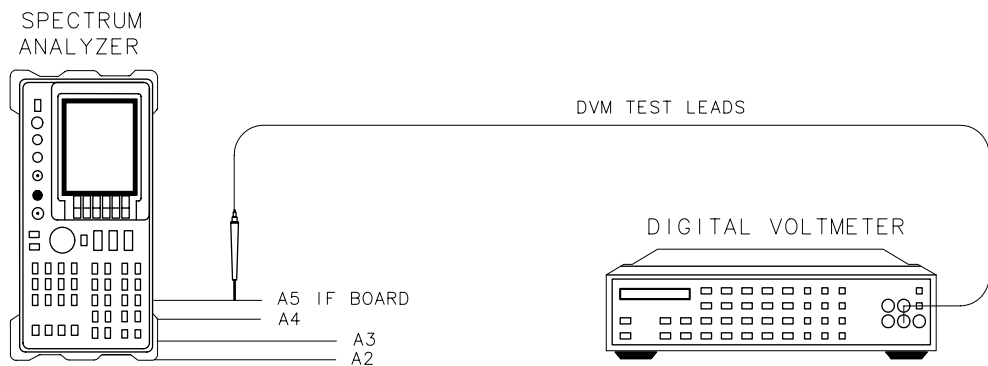

SK15

Equipment

| | |
|--|-----------|
| Digital voltmeter | HP3456A |
| DVM test leads | HP34118A |
| Special tuning tool (for slot-type tuning slugs) | 8710-1010 |
| Special tuning tool (for fork-type tuning slugs) | 8710-0772 |

Procedure

1. Press **LINE** to turn the spectrum analyzer off and disconnect the power cord. Remove the spectrum analyzer cover and fold down the A2 controller, A3 interface, A4 log amp, and A5 IF assemblies. Reconnect the power cord and press **LINE** to turn the spectrum analyzer on. Allow the spectrum analyzer to warm up for at least 30 minutes.
2. Connect the negative DVM lead to pin 6 of A5J6. See [Figure 2-5 on page 70](#). Set the HP 3456A controls as follows:

| | |
|----------------|----------|
| Function | DC VOLTS |
| Range | 10 V |

3. On the HP 8560E/EC, press **PRESET**, **SPAN**, **2**, **MHz**, **CAL**, and **IF ADJ OFF**.

LC Bandpass Adjustments

4. On the HP 8560E/EC, press **ADJ CURR IF STATE**. Wait for the **IF ADJUST STATUS** message to disappear before continuing with the next step.
5. Read the voltage on A5TP5 (this is an empty hole type of test point). If the voltage is less than +6.06 Vdc, turn A5L300 LC CTR 1 clockwise. If the voltage is greater than +6.26 Vdc, turn LC CTR 1 counterclockwise.
6. Repeat steps 4 and 5 until the voltage reads +6.16 Vdc \pm 100 mV.

NOTE

If the range for the LC CTR adjustment is insufficient, replace the appropriate factory-selected capacitor as listed in [Table 2-6 on page 72](#). To determine the correct replacement value, center the LC CTR adjustment and press **ADJ CURR IF STATE**. After the **IF ADJUST STATUS** message disappears, read the DVM display. Choose a capacitor value from [Table 2-7 on page 72](#), based on the DVM reading and the presently loaded capacitor value. [Table 2-10 on page 74](#) lists a few capacitor part numbers.

CAUTION

Press **LINE** to turn the spectrum analyzer off before removing or replacing any shield.

7. Move the positive DVM lead to A5TP6.

3. IF Bandpass Adjustment

8. Adjust A5L301 LC CTR 2 by repeating steps 4 through 6.
9. Move the positive DVM test lead to A5TP2 (this is a resistor-lead type of test point).
10. Adjust A5L700 LC CTR 3 by repeating steps 4 through 6.
11. Move the positive DVM test lead to A5TP1 (this is a resistor-lead type of test point).
12. Adjust A5L702 LC CTR 4 using the procedure in steps 4 through 6.

Table 2-6

Factory-Selected LC Filter Capacitors

| LC CTR Adjustment | Fixed Factory Select Capacitor |
|-------------------|--------------------------------|
| A5L300 LC CTR 1 | A5C326 |
| A5L301 LC CTR 2 | A5C327 |
| A5L700 LC CTR 3 | A5C717 |
| A5L702 LC CTR 4 | A5C718 |

Table 2-7

LC Factory-Selected Capacitor Selection

| DVM Reading (V) | Currently Loaded Capacitor Value (pF) | | | | | | |
|-----------------|---------------------------------------|----------------------|---------------------|---------------------|---------------------|---------------------|---------------------|
| | Replace 6.8 with: | Replace 8.2 with: | Replace 10 with: | Replace 12 with: | Replace 15 with: | Replace 18 with: | Replace 20 with: |
| 0 to 1.5 | * | * | * | * | * | * | * |
| 1.5 to 2.5 | 18 | 18 | * | * | * | * | * |
| 2.5 to 3.5 | 15 | 15 | 18 | 18 | * | * | * |
| 3.5 to 4.5 | 10 | 12 | 15 | 15 | 18 | * | * |
| 4.5 to 5.5 | 8.2 | 10 | 12 | 15 | 18 | * | * |
| 5.5 to 6.5 | no change | no change | no change | no change | no change | no change | no change |
| 6.5 to 7.5 | no change | no change | no change | no change | no change | no change | no change |
| 7.5 to 8.5 | * | 6.8 | 8.2 | 10 | 12 | 15 | 18 |
| 8.5 to 9.5 | * | * | 6.8 | 8.2 | 12 | 15 | 18 |
| 9.5 to 10 | * | * | 6.8 | 8.2 | 10 | 12 | 15 |

* Indicates a condition that should not exist; suspect broken hardware.

XTAL Bandpass Adjustments

13. On the HP 8560E/EC, press **SPAN**, **1**, **MHz**, and **CAL**.
14. Move the positive DVM test lead to A5TP7.
15. On the HP 8560E/EC, press **ADJ CURR IF STATE**. Wait for the **IF ADJUST STATUS** message to disappear before continuing to the next step.
16. Read the voltage displayed on the DVM. If the voltage is less than +6.06 Vdc, turn A5T200 XTAL CTR 1 clockwise. If the voltage is greater than +6.26 Vdc, turn XTAL CTR 1 counterclockwise.
17. Repeat steps 15 and 16 until the voltage reads +6.16 Vdc \pm 100 mV.

NOTE

If the range for the XTAL CTR adjustment is insufficient, replace the appropriate factory-selected capacitor as listed in [Table 2-9 on page 74](#). To determine the correct replacement value, center the XTAL CTR adjustment, and press **ADJ CURR IF STATE**. After the **IF ADJUST STATUS** message disappears, read the DVM display. Choose a capacitor value from [Table 2-10 on page 74](#), based on the DVM reading and the presently loaded capacitor value. [Table 2-10 on page 74](#) lists a few capacitor part numbers.

CAUTION

Press **LINE** to turn the spectrum analyzer off before removing or replacing any shield.

18. Move the positive DVM test lead to A5TP8.
19. Adjust A5T202 XTAL CTR 2 using steps 15 through 17.
20. Move the positive DVM test lead to A5TP3.
21. Adjust A5T500 XTAL CTR 3 using steps 15 through 17.
22. Move the positive DVM test lead to A5TP4.
23. Adjust A5T502 XTAL CTR 4 using steps 15 through 17.

Table 2-8

Factory-Selected XTAL Filter Capacitors

| XTAL CTR Adjustment | Fixed Factory Select Capacitor |
|---------------------|--------------------------------|
| A5T200 XTAL CTR 1 | A5C204 |
| A5T202 XTAL CTR 2 | A5C216 |
| A5T500 XTAL CTR 3 | A5C505 |
| A5T502 XTAL CTR 4 | A5C516 |

Table 2-9 XTAL Factory-Selected Capacitor Selection

| DVM Reading (V) | Currently Loaded Capacitor Value (pF) | | | | | |
|-----------------|---------------------------------------|------------------|------------------|------------------|------------------|------------------|
| | Replace 15 with: | Replace 18 with: | Replace 20 with: | Replace 22 with: | Replace 24 with: | Replace 27 with: |
| 0 to 1.5 | * | * | * | * | * | * |
| 1.5 to 2.5 | 27 | * | * | * | * | * |
| 2.5 to 3.5 | 22 | 27 | 27 | * | * | * |
| 3.5 to 4.5 | 18 | 22 | 24 | 27 | 27 | * |
| 4.5 to 5.5 | 18 | 20 | 22 | 24 | 27 | * |
| 5.5 to 6.5 | no change | no change | no change | no change | no change | no change |
| 6.5 to 7.5 | no change | no change | no change | no change | no change | no change |
| 7.5 to 8.5 | * | 15 | 18 | 18 | 22 | 24 |
| 8.5 to 9.5 | * | 15 | 15 | 18 | 20 | 24 |
| 9.5 to 10 | * | * | 15 | 18 | 20 | 24 |

* Indicates a condition that should not exist; suspect broken hardware.

Table 2-10 Capacitor Part Numbers

| Capacitor Value (pF) | HP Part Number |
|----------------------|----------------|
| 6.8 | 0160-4793 |
| 8.2 | 0160-4792 |
| 10 | 0160-4791 |
| 12 | 0160-4790 |
| 15 | 0160-4789 |
| 18 | 0160-4788 |
| 20 | 0160-5699 |
| 22 | 0160-4787 |
| 24 | 0160-5903 |
| 27 | 0160-4786 |

4. IF Amplitude Adjustments

The IF Amplitude Adjustments consist of the Cal Oscillator Amplitude adjustment and the Reference 15 dB Attenuator adjustment.

Assembly Adjusted

A4 log amp/cal oscillator A5 IF assembly

Related Performance Tests

IF Gain Uncertainty Scale Fidelity

Equipment

Frequency synthesizer HP3335A

Adapters

Type N (m) to BNC (f) 1250-1476

Cables

BNC, 122 cm (48 in) HP10503A

Test cable 85680-60093

Figure 2-6 IF Amplitude Adjustment Setup

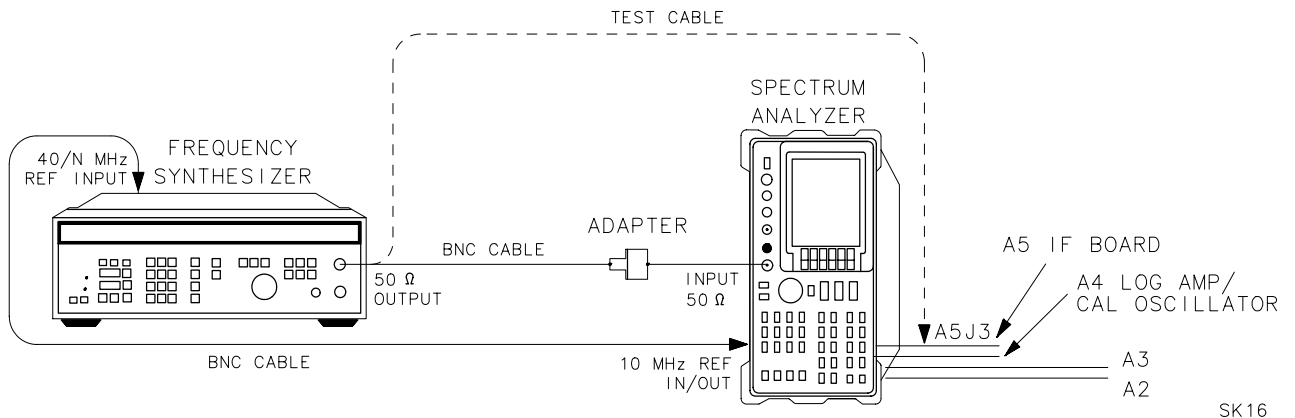
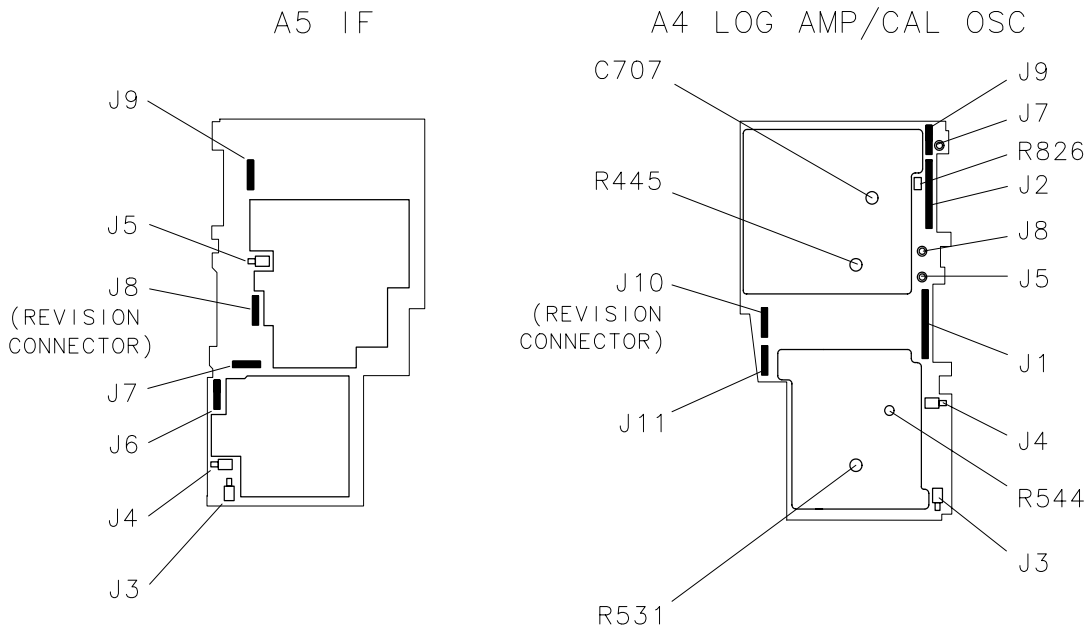

Figure 2-7 IF Amplitude Adjustment Locations



sj11e

A4 Log Amp/Cal Oscillator Amplitude Adjustment

This adjustment sets the output amplitude of the cal oscillator on the A4 assembly, and the absolute amplitude of the reference 15 dB attenuator.

The output of the cal oscillator is adjusted so that a -55 dBm signal applied to the 10.7 MHz IF input on the A5 IF assembly (A5J3) causes a displayed signal of -60 dBm. The effect of this adjustment is visible only after the **ADJ CURR IF STATE** sequence is complete. **ADJ CURR IF STATE** causes the IF gain adjustment to use the "new" output amplitude from the cal oscillator. When the adjustment sequence is complete, the result of the adjustment should cause the -35 dBm signal at A5J5 to be displayed at -60 dBm.

This procedure also sets the attenuator of the reference 15 dB attenuator so that a source amplitude change of 50 dB combined with a spectrum analyzer reference level change of 50 dB displays an amplitude difference of 50 dB.

NOTE The 15 dB reference attenuator adjustment is preset at the factory and need not be done if the entire A5 IF assembly is replaced.

Procedure

1. Press **LINE** to turn the spectrum analyzer off. Remove the spectrum analyzer cover and place the spectrum analyzer in the service position as illustrated in [Figure 2-6 on page 75](#). See [Figure 2-7 on page 76](#) for adjustment location.
2. Disconnect W29, violet coax cable, from A5J3. Connect the test cable between A5J3 and the 50 Ω output of the HP 3335A. Press **LINE** to turn the spectrum analyzer on.

3. Set the HP 8560E/EC controls as follows:

| | |
|------------------------|----------------|
| Center frequency | 10.7 MHz |
| Span | 200 kHz |
| Reference level | -60 dBm |
| Attenuator | 0 dB |
| Log/division | 1 Log/division |
| Resolution BW | 300 kHz |
| Video BW | 100 Hz |

4. On the HP 8560E/EC, press **MKR**, **CAL**, and **IF ADJ OFF**.

5. Set the HP 3335A controls as follows:

| | |
|-----------------|----------|
| Frequency | 10.7 MHz |
| Amplitude | -55 dBm |

6. Note the marker value. Ideally it should read $-60 \text{ dBm} \pm 0.1 \text{ dB}$.
7. If the marker reads less than -60.1 dBm , rotate A4R826 CAL OSC AMPTD one-third turn counter-clockwise for every 0.1 dB less than -60 dBm . See [Figure 2-7 on page 76](#) for the location of A4R826.
8. If the marker reads greater than -59.9 dBm , rotate A4R826 CAL OSC AMPTD one-third turn clockwise for every 0.1 dB greater than -60 dBm . A change in the displayed amplitude will not be seen at this point.

NOTE

If A4R826 has inadequate range, refer to "Inadequate CAL OSC AMPTD Range" in Chapter 9.

9. Press **ADJ CURR IF STATE**. After allowing the spectrum analyzer time to complete the adjustments, the displayed amplitude and marker reading should change.
10. Repeat steps 7 and 8 until the marker reads $-60 \text{ dBm} \pm 0.1 \text{ dB}$.
11. Disconnect the test cable from A5J3 and reconnect W29 to A5J3.

A5 Reference Attenuator Adjustment

1. Set the HP 3335A **AMPLITUDE** to -60 dBm.
2. Connect a BNC cable between the $50\ \Omega$ output of the HP 3335A and the HP 8560E/EC **INPUT $50\ \Omega$**
3. On the HP 8560E/EC, press **CAL** and **REF LEVEL ADJUST**. Use the front panel knob or step keys to place the peak of the displayed signal 3 dB to 5 dB below the reference level.
4. On the HP 8560E/EC, press **PEAK SEARCH** and **MARKER DELTA**. Set the spectrum analyzer reference level to -10 dBm.
5. Change the HP 3335A **AMPLITUDE** to -10 dBm.
6. On the HP 8560E/EC, press **CAL**.
7. Note the Δ MKR amplitude. Ideally, it should read $50.00\ \text{dB} \pm 0.1\ \text{dB}$.
8. If the Δ MKR amplitude is less than $49.9\ \text{dB}$, rotate A5R343 (15 dB **ATTEN**) one-half turn counterclockwise for each $0.1\ \text{dB}$ less than $50.00\ \text{dB}$. If the Δ MKR amplitude is greater than $50.1\ \text{dB}$, rotate A5R343 one-half turn clockwise for each $0.1\ \text{dB}$ greater than $50.00\ \text{dB}$. Do not adjust A5R343 more than five turns before continuing with the next step.
9. On the HP 8560E/EC, press **ADJ CURR IF STATE**. Note the Δ MKR amplitude reading.
10. Set the HP 8560E/EC reference level to -60 dBm and press **MKR** and **MARKERS OFF**.
11. Repeat steps 12 through 21 until the Δ MKR amplitude reading is $50.00\ \text{dB} \pm 0.1\ \text{dB}$.

A5 Adjustment Verification

1. On the HP 8560E/EC, disconnect W29 from A5J3. Connect the test cable between A5J3 and the $50\ \Omega$ output of the HP 3335A.
2. Set the HP 8560E/EC reference level to -10 dBm.
3. Set the HP 3335A **AMPLITUDE** to -5 dBm.
4. On the HP 8560E/EC press **MKR** and **MARKER NORMAL**.
5. The **MARKER** amplitude should read $-10\ \text{dBm} \pm 0.13\ \text{dB}$. If the reading is outside of this range, repeat steps 3 through 21.

6. On the HP 8560E/EC, reconnect W29 to A5J3. Press **PRESET** and set the controls as follows:

Center frequency 300 MHz
Span 0 Hz
Reference level -10 dBm
Resolution BW 300 kHz

7. Connect a BNC cable between the HP 8560E/EC CAL OUTPUT and INPUT 50Ω
8. On the HP 8560E/EC, press **MKR**, **CAL**, and **REF LVL ADJ**.
9. Use the knob or step keys to adjust the REF LEVEL CAL setting until the MKR reads -10.00 dBm ±0.1 dB.
10. On the HP 8560E/EC, press **STORE REF LVL**.

5. DC Log Amplifier Adjustments

There are three DC Log adjustments; Limiter Phase, Linear Fidelity, and Log Fidelity.

These adjustments need only be done under the following conditions:

Limiter Phase Only if a repair is made to blocks F, G, H, I, or J.

Linear Fidelity Only if a repair is made to blocks C, D, F, G, H, I, J, K, O, IF Gain Accuracy, RBW switching, or Log Fidelity.

Log Fidelity Only if a repair is made to blocks D, F, H, K, IF Gain Accuracy, RBW switching, or Log Fidelity.

If multiple adjustments are required, they should be done in the following order:

1. Limiter Phase
2. Linear Fidelity
3. Log Fidelity

All adjustments should be made with all of the shields on and only after allowing at least a 20-minute warmup.

Assembly Adjusted

A4 log amplifier

Related Performance Tests

IF Gain Uncertainty Scale Fidelity

Equipment

Frequency synthesizer HP 3335A

Adapters

Type N (m) to BNC (f) 1250-1476

Cables

BNC, 122 cm (48 in)HP10503A

Test cable85680-60093

A4 Limiter Phase Adjustment

This adjustment consists of adjusting A4R445 for maximum on screen amplitude under the following conditions.

Procedure

1. Press **LINE** to turn the spectrum analyzer off. Remove the spectrum analyzer cover and place the spectrum analyzer in the service position as illustrated in [Figure 2-8 on page 84](#). See [Figure 2-9 on page 85](#) for adjustment location.
2. Connect the HP 3335A 50 Ω output to the HP 8560E/EC 50 Ω input. Press **LINE** to turn the spectrum analyzer on.
3. Set the HP 8560E/EC controls as follows:

| | |
|------------------------|----------------|
| Center frequency | 15 MHz |
| Span | 0 |
| Reference level | -10 dBm |
| Log/division | 1 Log/division |
| Resolution BW | 300 kHz |
| IF Adjust | off |
4. Set up an HP 3335A as follows:

| | |
|-----------------|---------|
| Frequency | 15 MHz |
| Amplitude | -18 dBm |
5. Press **CAL** and **ADJ CURR IF STATE**, wait for the spectrum analyzer to complete adjustments, then press **MKR**.
6. Adjust A4R445 for maximum on-screen amplitude. Refer to [Figure 2-7 on page 76](#) for the location of A4R445.

A4 Linear Fidelity Adjustment

This adjustment consists of adjusting A4R544 until the delta marker reads -40 dB under the following conditions.

Procedure

1. Press **LINE** to turn the spectrum analyzer off. Remove the spectrum analyzer cover and place the spectrum analyzer in the service position as illustrated in [Figure 2-6 on page 75](#). See [Figure 2-7 on page 76](#) for adjustment location.
2. Connect the HP 3335A 50 Ω output to the HP 8560E/EC 50 Ω input. Press **LINE** to turn the spectrum analyzer on.
3. Press **PRESET**, **AMPLITUDE**, **LINEAR**, **MORE 1 of 3**, **AMPD UNITS**, **dBm**, **CAL**, and **IF ADJ OFF**.
4. Set the HP 8560E/EC controls as follows:

| | |
|------------------------|---------|
| Center frequency | 15 MHz |
| Span | 5 MHz |
| Resolution BW | 300 kHz |
| Reference level..... | -10 dBm |

5. Set up an HP 3335A as follows:

Frequency 15 MHz
Amplitude -18 dBm

6. Press **PEAK SEARCH** and **MARKER DELTA**.
7. Reduce the input power by 40 dB, to -58 dBm (use an attenuator or a source with a good relative amplitude accuracy).
8. If the signal is lower on the screen than expected (delta marker reads a change of greater than 40 dB, such as -41dB), then adjust A4R544 (see <Undefined Cross-Reference>) for an even lower level and press **CAL** and **ADJ CURR IF STATE**. Allow sufficient time for the spectrum analyzer to complete the adjustment.
9. If the signal is higher on the screen than expected (delta marker reads a change of less than 40 dB, such as reads -39 dB), then adjust A4R544 for an even higher level signal and press **CAL** and **ADJ CURR IF STATE**. Allow sufficient time for the spectrum analyzer to complete the adjustment.
10. Repeat the adjustment and adjust current state until the delta marker reads -40 dB \pm 2 dB.

A4 Log Fidelity Adjustment

This adjustment consists of adjusting A4R531 until the error is adjusted to zero.

Procedure

1. Press **LINE** to turn the spectrum analyzer off. Remove the spectrum analyzer cover and place the spectrum analyzer in the service position as illustrated in [Figure 2-6 on page 75](#). See [Figure 2-7 on page 76](#) for adjustment location.
2. Connect the HP 3335A 50 Ω output to the HP 8560E/EC 50 Ω input. Press **LINE** to turn the spectrum analyzer on.
3. Press **PRESET**, **CAL**, **IF ADJ OFF** and **ADJ CURR IF STATE**.
4. Set the HP 8560E/EC controls as follows:

Center frequency 15 MHz
Span 0
Resolution BW 300 kHz
Reference level -10 dBm
5. Set up an HP 3335A as follows:

Frequency 15 MHz
Amplitude -10 dBm

6. Press **MKR**, **MARKER DELTA** and decrease the source power to -26 dBm.
7. Calculate the error. The error = Delta Marker reading + 16 (in dB).
8. Set the source power to -10 dBm.
9. Adjust A4R531 (see [Figure 2-7 on page 76](#)) to read 2 times the error, press **CAL** and **ADJ CURR IF STATE**.
10. Repeat to check. Readjust as necessary to get error adjusted to zero.

6. Sampling Oscillator Adjustment

Assembly Adjusted

A15 RF assembly

Related Performance Test

There is no related performance test for this adjustment procedure.

Description

The sampling oscillator tank circuit is adjusted for a tuning voltage of 5.05 Vdc when the sampling oscillator is set to 297.222 MHz. The voltage monitored is actually the tuning voltage divided by 4.05. The setting is then checked at other frequencies for the full tuning range of the sampling oscillator.

Figure 2-8 **Sampler Adjustment Setup**

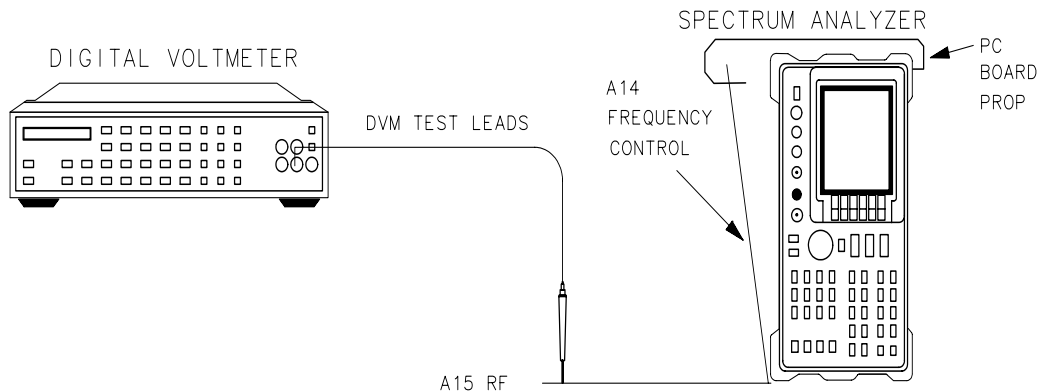

SK17

Equipment

Digital voltmeter HP 3456A
DVM test leads HP 34118A

Procedure

1. Press **LINE** to turn the spectrum analyzer off and disconnect the line power cord. Remove the spectrum analyzer cover and fold down the A15 RF and A14 frequency control assemblies. Prop up the A14 frequency control assembly. Reconnect the line power cord and press **LINE** to turn the spectrum analyzer on. Connect the equipment as illustrated in [Figure 2-8 on page 84](#).

2. Press **PRESET** on the HP 8560E/EC and set the controls as follows:

Center frequency2126 MHz
Span 0 Hz

3. Set the HP 3456A controls as follows:

Function DC VOLTS
Range10V,MANUAL

Sampling Oscillator Adjustment

1. Connect the negative DVM test lead to A15J200 pin 6. Connect the positive DVM lead to A15J200 pin 13.
2. Adjust A15C210 VCO RANGE for a DVM reading of 5.05 V \pm 0.05 V.

Figure 2-9 TAM Connector Pin Locations

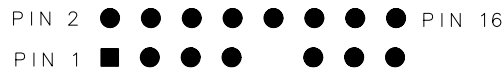

SP1

Sampler Match Adjustment

1. Connect the negative DVM test lead to A15J400 pin 6, and the positive DVM test lead to A15J400 pin 1.
2. Press **FREQUENCY** and set the HP 8560E/EC center frequency to 2302.3 MHz. This sets the sampling oscillator to 291.667 MHz.
3. Adjust A15C100 SMPL MATCH to peak the voltage displayed on the DVM.
4. Record the displayed voltage in [Table 2-11 on page 86](#) as the displayed voltage for the sampling oscillator frequency of 291.667 MHz.
5. Press **FREQUENCY** on the HP 8560E/EC. Use the keypad to set the spectrum analyzer center frequency to the frequencies listed in [Table 11 on page 86](#). At each listed frequency, record the displayed voltage in the table.

6. Sampling Oscillator Adjustment

6. If the difference between the maximum and minimum voltages is less than 0.50 V, and all voltage readings are between +0.5 and +2.5 Vdc, proceed to step 15.
7. Locate the center frequency at which the voltage is lowest. Use the keypad to set the HP 8560E/EC to this frequency.
8. Readjust SMPL MATCH to set the displayed voltage to 0.8 ± 0.1 Vdc.
9. Set the HP 8560E/EC center frequency to 2302.3 MHz and repeat steps 9 through 13.
10. Move the positive DVM test lead to A15J400 pin 3. Check that the measured voltage is the negative of the voltage at pin 1, within ± 0.1 Vdc.
11. Disconnect the DVM probes from A15J400.

Table 2-11

Sampling Adjustments

| Center Frequency (MHz) | Sampling Oscillator (MHz) | Displayed Voltage (Vdc) | | | | |
|------------------------|---------------------------|-------------------------|-----------|-----------|-----------|-----------|
| | | 1st Trial | 2nd Trial | 3rd Trial | 4th Trial | 5th Trial |
| 2156.3 | 285.000 | | | | | |
| 2176.3 | 286.364 | | | | | |
| 2230.3 | 288.462 | | | | | |
| 2263.3 | 290.000 | | | | | |
| 2302.3 | 291.667 | | | | | |
| 2158.3 | 293.478 | | | | | |
| 2196.3 | 295.000 | | | | | |
| 2378.3 | 296.471 | | | | | |
| 2422.3 | 297.222 | | | | | |

7. YTO Adjustment

Assembly Adjusted

A14 frequency control assembly

Related Performance Tests

Frequency Span Accuracy Frequency Readout Accuracy and Frequency Count Marker Accuracy

Description

The YTO main coil adjustments are made with the phase-lock loops disabled. The YTO endpoints are adjusted to bring these points within the capture range of the main loop. The YTO FM coil is adjusted to place the 300 MHz CAL OUTPUT signal at the center vertical graticule in a 20 MHz span.

Figure 2-10 YTO Adjustment Setup

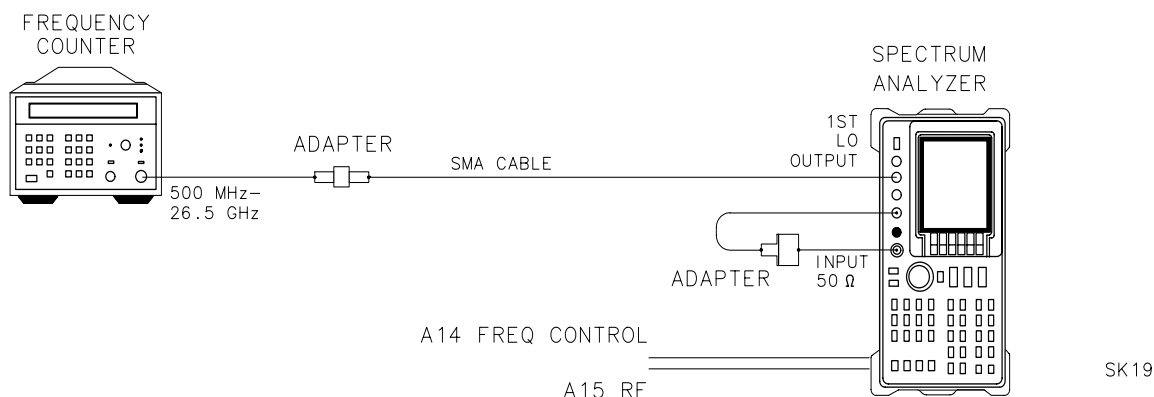

Equipment

Microwave frequency counter..... HP 5343A Option 001

Adapters

Type N (m) to BNC (f) 1250-1476
 Type N (f) to APC 3.5 (f) (*Option 026 only*) 1250-1745
 APC 3.5 (f) to APC 3.5 (f) 5061-5311

Cables

BNC, 122 cm (48 in) HP 10503A
 SMA, 61 cm (24 in) 8120-1578

Procedure

NOTE This adjustment cannot be performed if the spectrum analyzer preselected external mixer mode is selected.

YTO Main Coil Adjustments

1. Press **LINE** to turn the spectrum analyzer off. Remove the spectrum analyzer cover and fold down the A15 RF and A14 frequency control assemblies.
2. Disconnect the 50 Ω termination from the 1ST LO OUTPUT. Connect the equipment as shown in [Figure 2-10 on page 87](#). Press **LINE** to turn the spectrum analyzer on.
3. Move the jumper on A14J23 from the NORM position (pins 1 and 2 jumpered) to the TEST position (pins 2 and 3 jumpered).
4. If the HP 8560E/EC spectrum analyzer does not have Option 002, press the following keys:

CONFIG, EXT MXR PRE UNPR, (UNPR)

AUX CTRL, EXTERNAL MIXER, LOCK HARMONIC, 6 Hz

SPAN, ZERO SPAN

FREQUENCY, CENTER FREQ, 18.8893 GHz, SGL SWP

SAVE, SAVE STATE, STATE 0

FREQUENCY, 35.7493 GHz

SAVE, SAVE STATE, STATE 1

RECALL, RECALL STATE, STATE 0.

5. If the HP 8560E/EC spectrum analyzer has Option 002, press the following keys:

SPAN, ZERO SPAN

FREQUENCY, CENTER FREQ, 300 KHz

SAVE, SAVE STATE, STATE 0

FREQUENCY, 2.0993 GHz

SAVE, SAVE STATE, STATE 1

RECALL, RECALL STATE, STATE 0.

6. On the HP 5343A, press **SHIFT 7** and set the controls as follows:

SAMPLE RATE Fully Counterclockwise

10 Hz — 500 MHz/500 MHz — 26.5 GHz SWITCH 500 MHz — 26.5 GHz

7. Adjust A14R93 3.2 GHz for the appropriate frequency counter reading:
 - 3.200 GHz \pm 1 MHz
 - 3.911 GHz \pm 1 MHz if Option 002
8. On the HP 8560E/EC, press **STATE 1**.
9. Adjust A14R42 6.01 GHz for a frequency counter reading of 6.010 GHz \pm 1 MHz.
10. On the HP 8560E/EC, press **STATE 0**.
11. Repeat steps 6 through 9 until both of these interacting adjustments meet their tolerances.
12. Place the jumper on A14J23 in the NORM position (pins 1 and 2 jumpered).
13. Disconnect the SMA cable from the 1ST LO OUTPUT jack and reconnect the 50 Ω termination on the 1ST LO OUTPUT.

Figure 2-11 YTO Adjustment Locations

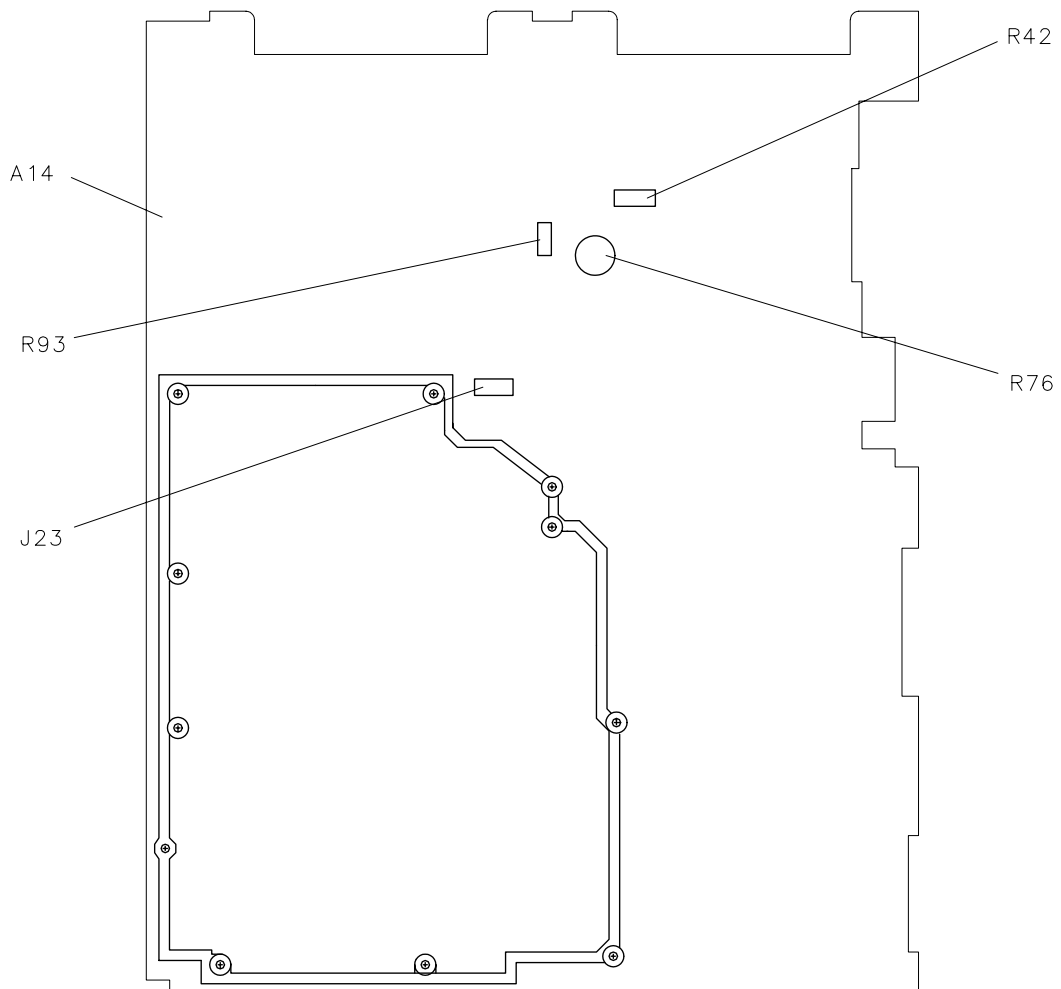

sp116e

YTO FM Coil Adjustments

1. On the HP 8560E/EC, press **PRESET** and set the controls as follows:
Center frequency 300 MHz
Span 20 MHz
2. Adjust A14R76 FM SPAN until the 300 MHz CAL OUTPUT SIGNAL is aligned with the center vertical graticule line.

8. First LO Distribution Amplifier Adjustment

Assembly Adjusted

A14 frequency control assembly

Related Performance Test

First LO OUTPUT Amplitude

Description

The gate bias and SENSE voltages for the A7 switched LO distribution amplifier is adjusted to the value specified on the label of A7.

Figure 2-12 First LO Distribution Amplifier Adjustment Setup

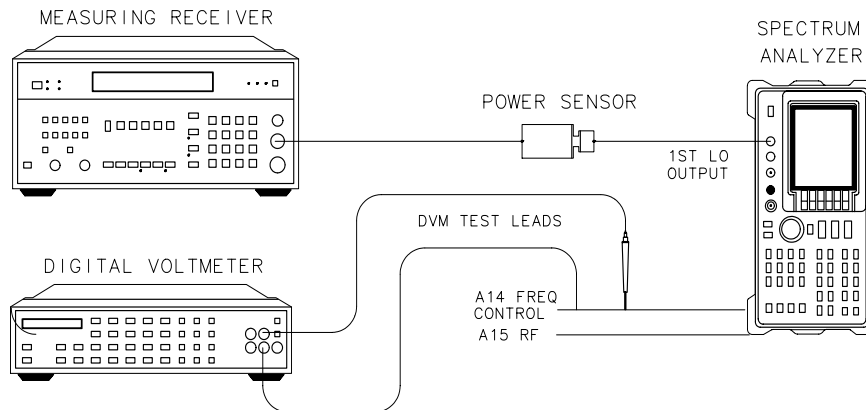

SK110

Equipment

| | |
|-------------------------|-----------|
| Measuring receiver..... | HP 8902A |
| DVM | HP 3456A |
| Power sensor | HP 8485A |
| DVM test leads | HP 34118A |

Procedure

1. Press **LINE** to turn the spectrum analyzer off and disconnect the line cord. Remove the cover and fold down the A15 RF and A14 Frequency Control assemblies.
2. Move the jumper on A2J12 from the WR PROT to the WR ENA position. The jumper is on the edge of the A2 board assembly and can be moved without folding the board down.
3. Reconnect the line cord and turn on the spectrum analyzer.
4. Set the HP 8560E/EC controls as follows:
 - Center frequency 1.45 GHz
 - Span 0 Hz
5. On the HP 8560E/EC, press **CAL, MORE 1 OF 2, SERVICE CAL DATA, LO LEVELS,** and **INT LO LEVEL.**
6. Use the knob or key pad to enter the value 32. This sets the LO power to a low level.
7. To set the gate bias, connect the positive lead of the DVM to A14J18 pin 15 and the negative lead to A14J18 pin 6. See [Figure 2-13 on page 92](#) for a pin location drawing.

Figure 2-13 TAM Connector Pin Locations

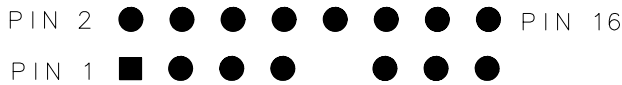

8. On the HP 8560E/EC, press **LO GATE LEVEL.**
9. Note the Gate Bias voltage printed on the A7 LO distribution amp label. Use the knob or keypad to change the displayed DAC value so the DVM reading is equal to the label voltage, ± 10 mV.
10. To set the low band sense voltage, connect the positive lead of the DVM to A14J18 pin 13 and the negative lead to A14J18 pin 6.
11. On the HP 8560E/EC press **INT LO LEVEL.** The message **DRIVE FOR BAND# 0** will be displayed.
12. Note the Sense voltage printed on the A7 LO distribution amp label. Use the knob or keypad, and press enter, to change the displayed DAC value so the DVM reading is equal to the label voltage, ± 5 mV.
13. Record the DAC value:

DAC value for 1.45 GHz = _____

14. Set the "Sense EXT" value by pressing **EXT LO LEVEL**.
15. Use the knob or keypad to enter the DAC value for 1.45 GHz from the band 0 sense voltage adjustment above.
16. Save the adjustment values by pressing **PREV MENU**, **STORE DATA**, and **YES**.
17. Move the jumper on A2J12 from WR ENA back to the WR PROT position.

9. Tracking Generator Power Level Adjustments (Option 002)

Assembly Adjusted

A10 tracking generator assembly

Related Performance Test

Absolute Amplitude and Vernier Accuracy

Description

The A10 tracking generator has two adjustments for setting the output power. A10R13 -10 dB ADJ sets the power level when the TRK GEN RF POWER is set to -10 dBm and A10R18 0 dB ADJ sets the power level when the TRK GEN RF POWER is set to 0 dBm. The -10 dB ADJ acts as an offset adjustment while 0 dB ADJ acts as a gain adjustment.

These adjustments are set in the factory for a 10 dB difference in output power between the -10 dBm and 0 dBm TRK GEN RF POWER settings. When installing a replacement tracking generator, it should only be necessary to adjust -10 dB ADJ (the offset adjustment) to account for variations in cable loss from the tracking generator to the RF OUT 50Ω connector. This adjustment is done at a 0 dBm TRK GEN RF POWER setting. This ensures that the absolute power level with a 0 dBm TRK GEN RF POWER setting is 0 dBm with little effect, if any, on the vernier accuracy.

In some cases, the power level at the -10 dBm TRK GEN RF POWER setting might be out of tolerance. In such cases, the -10 dB ADJ is set at a TRK GEN RF POWER of -10 dBm and the 0 dB ADJ is set at a TRK GEN RF POWER of 0 dBm. These two adjustments must be iterated until the power level at the two settings are within the given tolerance.

Equipment

| | |
|--------------------------|----------|
| Measuring receiver | HP 8902A |
| Power sensor | HP 8482A |

Cable

| | |
|-----------------------------|-------------|
| Type N, 62 cm (24 in) | HP 11500B/C |
|-----------------------------|-------------|

Procedure

1. Press **LINE** to turn the spectrum analyzer off. Remove the spectrum analyzer cover and place the spectrum analyzer in the service position as illustrated in [Figure 2-14 on page 95](#).

Figure 2-14 Tracking Generator Power Setup and Adjustment Locations

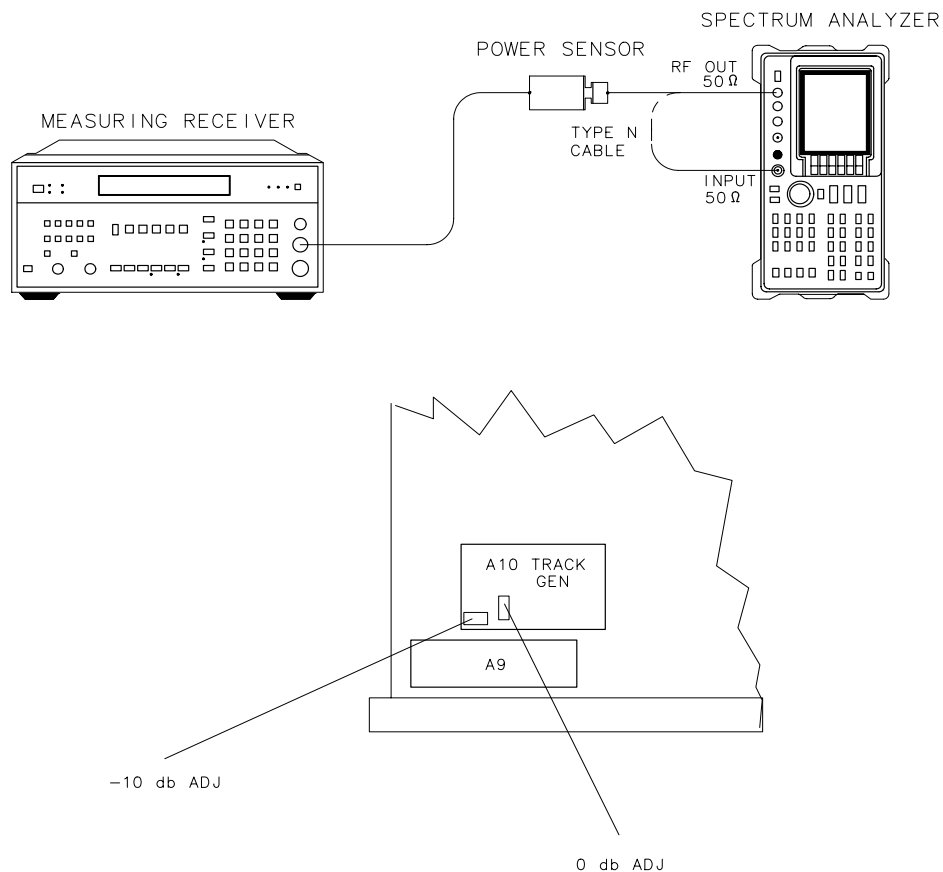

SJ11

2. Connect the Type N cable between the RF OUT 50Ω and RF INPUT 50Ω connectors on the HP 8560E/EC.
3. Press **PRESET** on the HP 8560E/EC and set the controls as follows:

| | |
|------------------------|---------|
| Center frequency | 300 MHz |
| Span..... | 0 Hz |

9. Tracking Generator Power Level Adjustments (Option 002)

4. On the HP 8560E/EC, press **MKR, AUX CTRL, TRACKING GENERATOR, SRC PWR ON, 0, and dBm**.
5. On the HP 8560E/EC, press **MORE 1 OF 3, TRACKING PEAK**. Wait for the **PEAKING** message to disappear.
6. Zero and calibrate the measuring receiver/power sensor combination in log mode (power levels readout in dBm). Enter the power sensor 300 MHz Cal Factor into the measuring receiver.
7. Disconnect the Type N cable from the RF OUT 50 Ω and connect the power sensor to the RF OUT 50 Ω .
8. On the HP 8560E/EC, press **0, dBm, and SGL SWP**.
9. Adjust A10R13 -10 dB ADJ for a 0 dBm ± 0.05 dB reading on the measuring receiver.
10. Set the TRK GEN RF POWER to -10 dBm. Note the power displayed on the measuring receiver.
11. Proceed with steps 12 through 14 only if the power level noted in the previous step was outside the range of -10 dBm ± 0.23 dB.
12. With the TRK GEN RF POWER set to -10 dBm, adjust A10R13 -10 dB ADJ for a -10 dBm ± 0.1 dB reading on the measuring receiver. Refer to [Figure 2-14 on page 95](#) for adjustment location.
13. Set the TRK GEN RF POWER to 0 dBm. Adjust A10R18 0 dB ADJ for a 0 dBm ± 0.2 dB reading on the measuring receiver. Refer to [Figure 2-14 on page 95](#) for adjustment location.

Sampling Adjustments

Power at -10 dBm Setting _____ dBm

14. Repeat steps 12 and 13 until the output power level is within the tolerances indicated at both the -10 dBm and 0 dBm TRK GEN RF POWER settings. Adjust -10 dB ADJ only with the TRK GEN RF POWER set to -10 dBm and adjust 0 dB ADJ only with the TRK GEN RF POWER set to 0 dBm.

10. Frequency Response Adjustment

Assembly Adjusted

A15 RF assembly

Related Performance Tests

Displayed Average Noise Level Frequency Response

Description

A signal of the same known amplitude is applied to the spectrum analyzer at several different frequencies. At each frequency, the DAC controlling the flatness compensation amplifiers is adjusted to place the peak of the displayed signal at the same place on the screen. With firmware revisions greater than 920528, there are correction points at 2 MHz and 6 MHz. These points are outside frequency range of the synthesized sweeper. The DAC values for these two points are set to a fixed offset from the DAC value at 10 MHz. The DAC values are stored in EEROM.

Figure 2-15 Frequency Response Adjustment Setup

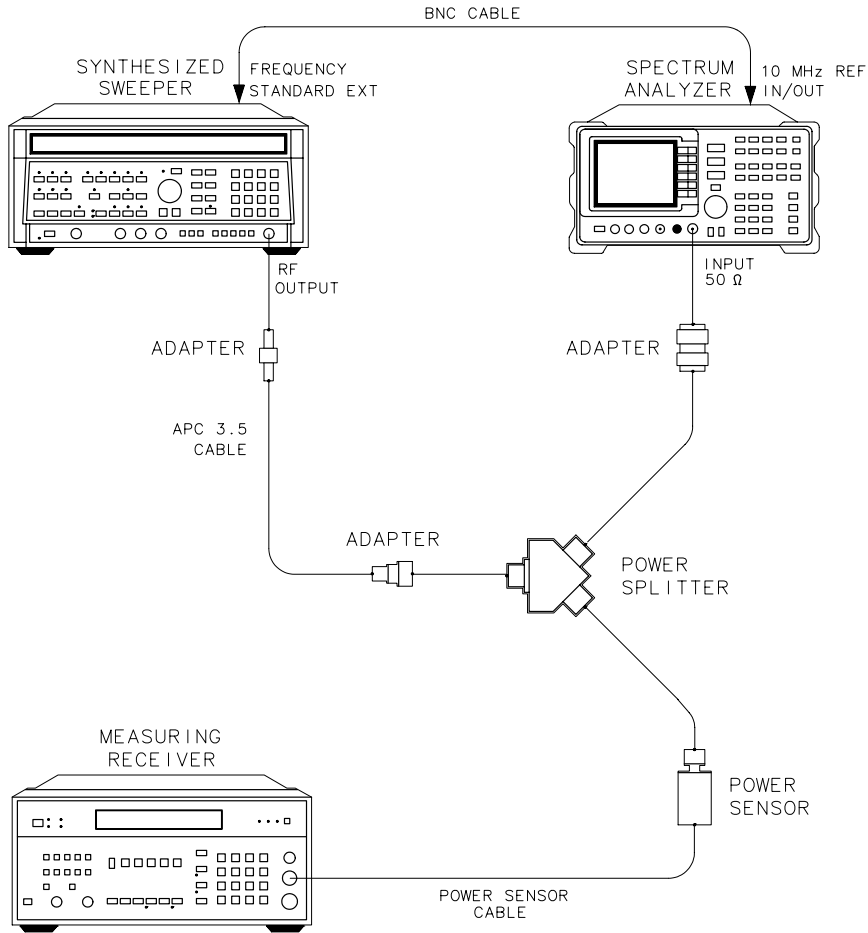

sj1

Equipment

- Synthesized sweeper HP 8340A/B
- Measuring receiver HP 8902A
- Power sensor HP 8482A
- Power splitter HP 11667A

Adapters

- Type N (m) to Type N (m) 1250-1475
- Type N (m) to APC 3.5 (f) 1250-1744
- Type APC 3.5 (f) to APC 3.5 (f) 5061-5311

Cables

- BNC, 122 cm (48 in) HP 10503A
- APC 3.5, 91 cm (36 in) 8120-4921

Procedure

1. Connect the equipment as shown in [Figure 2-15 on page 98](#). Do not connect the HP 8482A Power Sensor to the HP 11667B Power Splitter.
2. Zero and calibrate the HP 8902A/HP 8482A combination in log mode (power levels read out in dBm) and connect the power sensor through an adapter to the power splitter.
3. Place the WR PROT/WR ENA jumper on the A2 Controller assembly in the WR ENA position.
4. Press **PRESET** on the HP 8560E/EC and set the controls as follows:

| | |
|------------------------|---------|
| Center frequency | 10 MHz |
| Span | 0 Hz |
| Resolution BW | 300 kHz |
| Log/division | 2 dB |
5. Press **INSTR PRESET** on the HP 8340A/B and set the controls as follows:

| | |
|-------------------|--------|
| CW | 10 MHz |
| Power level | -4 dBm |
6. Set ref level cal DAC to zero. Press **CAL**, **REF LVL ADJ** and use the knob to set the value to 0. Press **STORE REF LVL**.
7. On the HP 8560E/EC, press **MKR**, **CAL**, **MORE 1 OF 2**, **SERVICE CAL DATA**, then **FLATNESS**. The current value of the RF Gain DAC should be displayed in the active function area. If the frequency displayed in the active function area is not 10 MHz, press \downarrow or \uparrow until 10 MHz is displayed.
8. Enter the appropriate Power Sensor Calibration factor into the HP 8902A.
9. Set the HP 8340A/B **CW** output to the frequency indicated in the active function area of the HP 8560E/EC display. Adjust the HP 8340A/B **POWER LEVEL** for a -10 dBm reading on the HP 8902A.

10. Frequency Response Adjustment

10. On the HP 8560E/EC spectrum analyzer, adjust the RF Gain DAC value using the front panel knob or keypad until the marker reads $-10 \text{ dBm} \pm 0.10 \text{ dB}$. Each DAC count yields an approximate 0.01 dB change.
11. On the spectrum analyzer, press \Downarrow to proceed to the next frequency.
12. Repeat steps 7 through 10 for all low-band frequencies $\geq 10 \text{ MHz}$.
13. If the firmware revision is later than 920528, perform steps 13 through 17. Otherwise, skip to step 18.
14. Press \Downarrow until 10 MHz is displayed in the active function block. Record the RF gain DAC value at 10 MHz.
10 MHz RF gain DAC value _____
15. Add 67 to the 10 MHz RF gain DAC value and record as the 2 MHz RF gain DAC value.
2 MHz RF gain DAC value _____
16. Add 62 to the 10 MHz RF gain DAC value and record as the 6 MHz RF gain DAC value.
6 MHz RF gain DAC value _____
17. Press \Downarrow until 2 MHz is displayed in the active function block. Use the DATA keys to enter the 2 MHz RF gain DAC value recorded in step 14.
18. Press \Downarrow until 6 MHz is displayed in the active function block. Use the DATA keys to enter the 6 MHz RF gain DAC value recorded in step 15.
19. Press **PREV MENU STORE DATA**, then **YES** on the HP 8560E/EC.
20. Place the WR PROT/WR ENA jumper on the A2 Controller assembly in the WR PROT position.

11. Calibrator Amplitude Adjustment

Assembly Adjusted

A15 RF assembly

Related Performance Test

Calibrator Amplitude and Frequency Accuracy

Description

The CAL OUTPUT amplitude is adjusted for -10.00 dBm measured directly at the front panel CAL OUTPUT connector.

Figure 2-16 Calibrator Amplitude Adjustment Setup

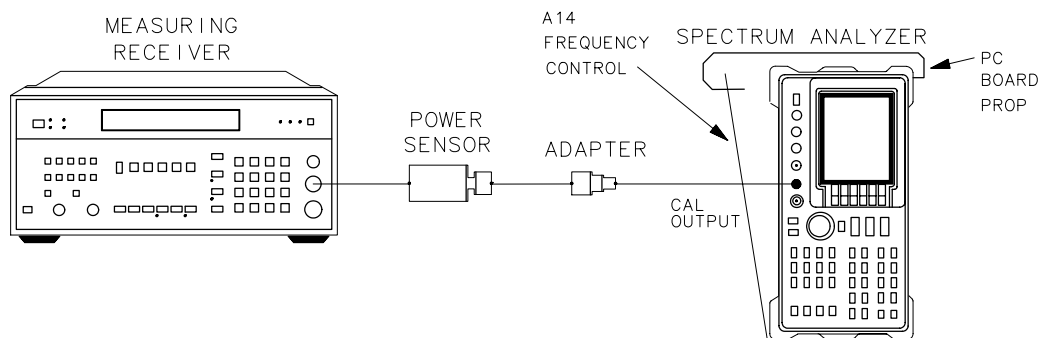

SK113

Equipment

Measuring receiver HP 8902A
Power sensor HP 8482A

Adapters

Type N (f) to BNC (m) 1250-1477

Procedure

NOTE

The HP 8560E/EC should be allowed to warm up for at least 30 minutes before performing this adjustment.

1. Place the HP 8560E/EC in the service position shown in [Figure 2-16 on page 101](#). Prop the A14 Frequency Control Board assembly in the service position.
2. Zero and calibrate the HP 8902A/HP 8482A combination in log display mode. Enter the power sensor 300 MHz Cal Factor into the HP 8902A.
3. Connect the HP 8482A through an adapter directly to the HP 8560E/EC CAL OUTPUT connector.
4. Adjust A15R561 CAL AMPTD for a -10.00 dBm reading on the HP 8902A display.

12. 10 MHz Reference Adjustment-TCXO (Option 103)

Assembly Adjusted

A15 RF assembly

Related Performance Test

10 MHz Reference Output Accuracy

Description

The frequency counter is connected to the CAL OUTPUT, which is locked to the 10 MHz reference. This yields better effective resolution. The temperature-compensated crystal oscillator (TCXO) is adjusted for a frequency of 300 MHz as read by the frequency counter.

Figure 2-17 10 MHz Frequency Reference Adjustment Setup

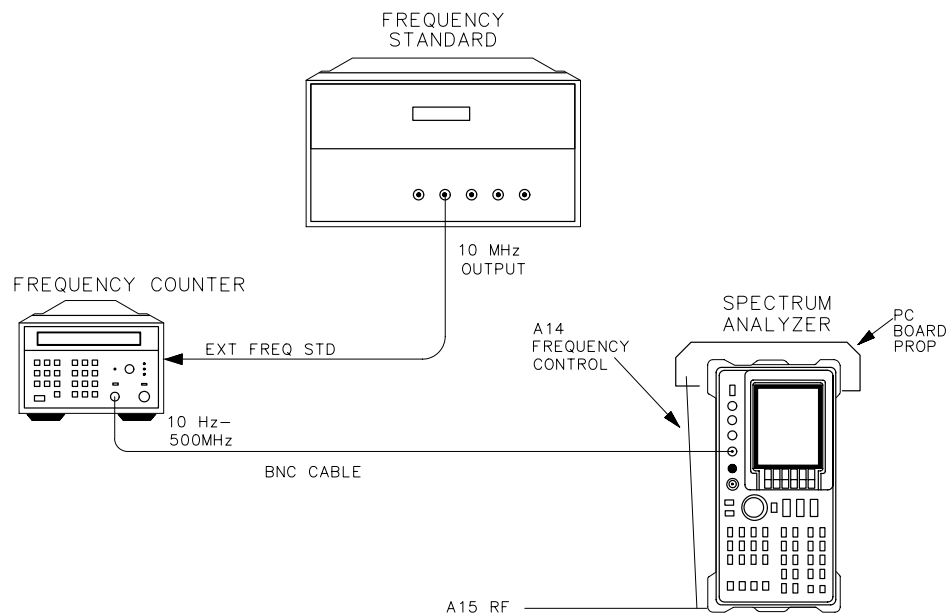

SP11E

Equipment

Microwave frequency counter HP 5343A Option 001
 Frequency standard HP 5061B Cesium Beam Standard
 (or any 10 MHz frequency standard with accuracy $<\pm 1 \times 10^{-10}$)

Cables

BNC, 122 cm (2 required) HP 10503A

Procedure

NOTE

Allow the HP 8560E/EC spectrum analyzer to warm up for at least 30 minutes before performing this adjustment.

1. Connect the equipment as shown in [Figure 2-17 on page 103](#). Prop up the A14 Frequency Control Assembly.
2. Set the HP 5343A controls as follows:

| | |
|---|-----------------|
| SAMPLE RATE | Midrange |
| 50 Ω — 1 M Ω SWITCH | 50 Ω |
| 10 Hz — 500 MHz/500 MHz — 26.5 GHz SWITCH | 10 Hz — 500 MHz |
3. Press **AUX CTRL**, **REAR PANEL**, and ensure that the 10 MHz reference is set to **10 MHz INT**.

NOTE

When the 10 MHz reference is set to **10 MHz EXT**, the TCXO is not operating and warmed up. If the reference is set to **10 MHz EXT**, set the reference to **10 MHz INT** and allow 30 minutes for the TCXO to warm up.

4. Remove dust cap from A15U302, TCXO. The dust cap is toward the rear of the spectrum analyzer.
5. Adjust 10 MHz ADJ on A15U302 for a frequency counter reading of 300.000000 MHz ± 30 Hz.
6. Replace the dustcap on A15U302.

13. Demodulator Adjustment

Assembly Adjusted

A4 log amplifier assembly

Related Performance Test

There is no related performance test for this adjustment procedure.

Description

A 5 kHz peak deviation FM signal is applied to the INPUT 50Ω. The detected audio is monitored by an oscilloscope. FM DEMOD is adjusted to peak the response displayed on the oscilloscope.

Figure 2-18 Demodulator Adjustment Setup

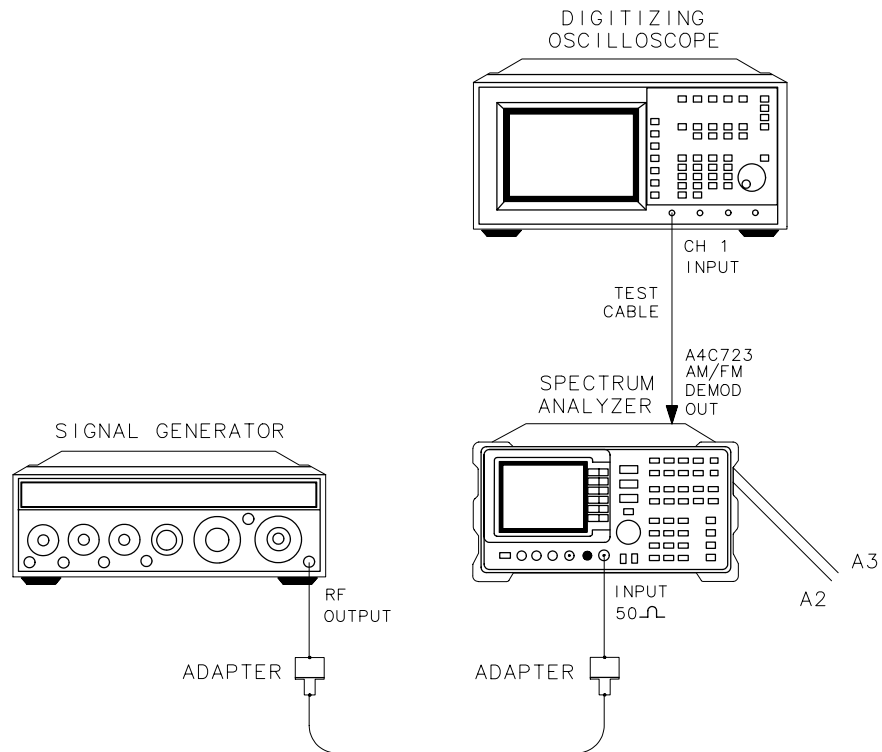

s

Equipment

AM/FM signal generator HP 8640B
Oscilloscope HP 1980A/B

Adapters

Type N (m) to BNC (f) (*2 required*)..... 1250-1476

Cables

BNC, 122 cm (48 in) HP 10503A
Oscilloscope probe HP 10432A

Procedure

1. Press **LINE** to turn the spectrum analyzer off. Place the spectrum analyzer in the service position as illustrated in [Figure 2-18 on page 105](#).
2. Connect the oscilloscope probe from the oscilloscope channel 1 input to probe A4C723 (the end closest to A4U707) as in [Figure 2-19 on page 107](#). Press **LINE** to turn the spectrum analyzer on. Connect the HP 8640B RF OUTPUT to the HP 8560E/EC INPUT 50 Ω .
3. Set the HP 8640B controls as follows:

Range MHz 61 to 128
Frequency 100.000 MHz
Output level -10 dBm
RF..... ON
AM OFF
FM INT
Modulation frequency 1000 Hz
Peak deviation 5 kHz
Scale FM (k/MHz)

4. Adjust the HP 8640B FM deviation vernier for a full-scale reading on the meter. Set the FM to off.
5. Set the oscilloscope controls as follows:

Channel 1 on
Channel 2 off
Channel 1 50 mV/div
Channel 1 ac
Channel 1 BW lim
Time base 1.0 ms/div
Trigger auto
Trigger source 1
Trigger level 0.0 V

6. On the HP 8560E/EC, press **PRESET** and set the controls as follows:
Center frequency 100 MHz
Span 5 MHz
Ref level -10 dBm
Resolution BW 100 kHz
7. On the HP 8560E/EC press: **PEAK SEARCH, MARKER** →
CF SPAN, ZERO SPAN AUX CTRL, AM/FM DEMOD, FM DEMOD ON OFF
(ON) **CAL, IF ADJ ON OFF (OFF) TRIG**, and **SWEEP CONT SGL (SGL)**.
Set the volume control to midrange.
8. Set the HP 8640B FM to INT.
9. A 1 kHz sine wave should be observed on the oscilloscope. Rotate the volume knob on the front panel of the spectrum analyzer until the amplitude of the 1 kHz signal is at about 150 mV (3 divisions on the oscilloscope).
10. Adjust A4C707 FM DEMOD for a maximum peak-to-peak response on the oscilloscope.
11. Press **LINE** to turn the spectrum analyzer off. Disconnect the test cable from A4C723.

Figure 2-19 Demodulator Adjustment Locations

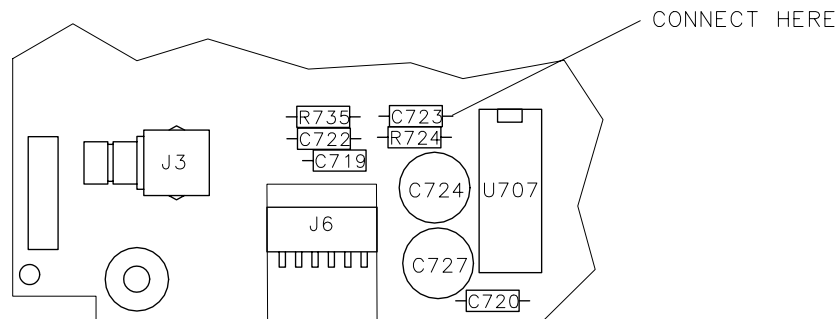

SP115E

14. External Mixer Bias Adjustment

(Non-Option 002 and Non-Option 327)

Assembly Adjusted

A15 RF assembly

Related Performance Test

There is no related performance test for this adjustment procedure.

Description

A voltmeter is connected to the HP 8560E/EC IF INPUT with the external mixer bias set to off. The bias is adjusted for a 0 Vdc output.

Figure 2-20 External Mixer Bias Adjustment Setup

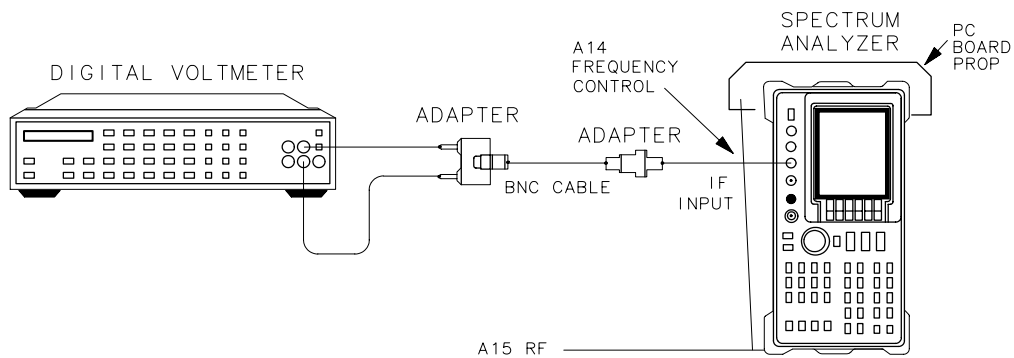

SK116

Equipment

DVM..... HP 3456A

Adapters

Type BNC (f) to SMA (m) 1250-1200

Type BNC (f) to dual banana plug 1251-2816

Cables

BNC, 122 cm (48 in)..... HP 10503A

Procedure

1. Press **LINE** to turn the spectrum analyzer off and disconnect the ac power cord. Remove the spectrum analyzer cover and connect the equipment as illustrated in [Figure 2-20 on page 108](#). Reconnect the power cord and press **LINE** to turn the spectrum analyzer on.
2. Set the HP 3456A controls as follows:
Function..... DC VOLTS
Range 0.1 V
Resolution 100 mV
3. On the HP 8560E/EC, press **AUX CTRL**, **EXTERNAL MIXER**, **BIAS**, then **BIAS OFF**.
4. Adjust A15R926 EXT BIAS ZERO for a DVM reading of 0.000 Vdc ± 12.5 mV.

15. External Mixer Amplitude Adjustment

Assembly Adjusted

A15 RF assembly

Related Performance Test

IF Input Amplitude Accuracy

Description

The slope of the flatness compensation amplifiers is determined. The user-loaded conversion losses for K-band are recorded and reset to 30 dB. A 310.7 MHz signal is applied to the power sensor and the power level of the source is adjusted for a -30 dBm reading. The signal is then applied to the IF INPUT. The flatness compensation amplifiers are then adjusted (via DACs) to place the displayed signal at the reference level. Only the determination of the Flatness Compensation Amplifier slope is performed if the HP 8560E/EC has Option 002.

Figure 2-21 External Mixer Amplitude Adjustment Setup

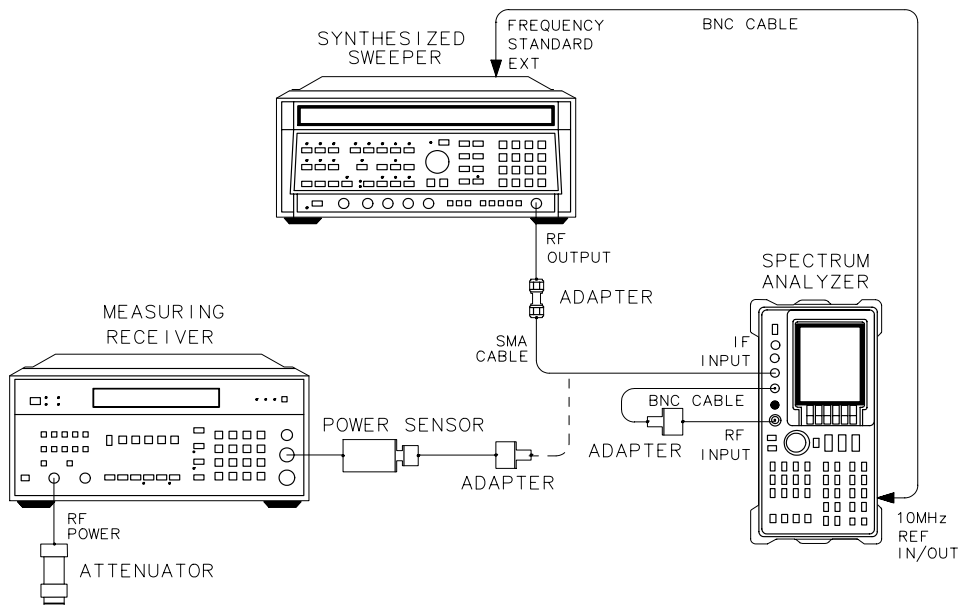

SK117

Equipment

| | |
|-----------------------------------|---------------------------------------|
| Synthesized sweeper | HP 8340A/B |
| Measuring receiver | HP 8902A |
| Power sensor. | HP 8484A, 8481D |
| 50 MHz reference attenuator | HP 11708A (supplied with HP 8481D) |

Adapters

| | |
|---------------------------------------|-----------|
| Type N (f) to SMA (f) | 1250-1772 |
| Type N (m) to BNC (f) | 1250-1476 |
| Type APC 3.5 (f) to APC 3.5 (f) | 5061-5311 |

Cables

| | |
|---------------------------|-----------|
| BNC, 122 cm (48 in) | HP 10503A |
| SMA, 61 cm (24 in) | 8120-1578 |

Procedure

1. Press **LINE** to turn the spectrum analyzer off and disconnect the power cord. Remove the spectrum analyzer cover and reconnect the power cord.
2. Set up the equipment as illustrated in [Figure 2-21 on page 110](#). Do not connect the SMA cable to the HP 8560E/EC.
3. Move the WR PROT/WR ENA jumper on the A2 Controller assembly to the WR ENA position. (The jumper is on the edge of the A2 controller assembly and can be moved without folding the board down.) Press **LINE** to turn the spectrum analyzer on.
4. On the HP 8560E/EC, press **AUX CTRL**, **EXTERNAL MIXER**, **AMPTD CORRECT**, then **CNV LOSS VS FREQ**.
5. On the HP 8560E/EC, press **CAL**, **MORE 1 OF 2**, **SERVICE CAL DATA**, **3RD IF AMP**, and **CAL 3RD AMP GAIN**. Wait until the message **ADJUSTMENT-DONE** appears in the active function block.

NOTE

Perform steps 6 through 13 only if the HP 8560E/EC does not have Option 002.

6. Press \Downarrow or \Downarrow to display the conversion loss value for each frequency listed in [Table 2-12 on page 112](#). Record any conversion loss reading *not equal* to 30 dB in [Table 2-12 on page 112](#) at the appropriate frequency.
7. If all conversion loss values equal 30 dB, skip to step 8, otherwise continue to step a.
 - a. Refer to [Table 2-12 on page 112](#) and press \Downarrow or \Downarrow to select a frequency at which the conversion loss value does not equal 30 dB.

15. External Mixer Amplitude Adjustment

- b. Use the spectrum analyzer front panel keys to set the conversion loss value to 30 dB.
 - c. Repeat steps a and b for all frequencies having a conversion loss value other than 30 dB.
8. Press **INSTR PRESET** on the HP 8340A/B and set the controls as follows:

CW frequency 310.7 MHz
 Power level -30 dBm

Table 2-12

Conversion Loss Data

| Frequency (GHz) | Conversion Loss (dB) ($\neq 30$ dB) |
|-----------------|--------------------------------------|
| 18 | |
| 20 | |
| 22 | |
| 24 | |
| 26 | |
| 27 | |

9. Connect the power sensor to the HP 11708A attenuator already connected to the HP 8902A RF power connector. Zero and calibrate the HP 8902A/power sensor combination in log mode. Enter the power sensor 50 MHz Cal Factor into the HP 8902A. Connect the power sensor, through an adapter, to the SMA cable.
10. Adjust the HP 8340A **POWER LEVEL** until the power displayed on the HP 8902A reads -30 dBm ± 0.05 dB.
11. Disconnect the SMA cable from the power sensor/adapter and connect the cable to the HP 8560E/EC IF INPUT.
12. On the HP 8560E/EC, press **CAL, MORE 1 OF 2, SERVICE CAL DATA, 3RD IF AMP**, then **EXT MXR REF CAL**.

13. Use the HP 8560E/EC front panel knob, step keys, or keypad to change the amplitude of the displayed signal until the marker reads 0 dBm \pm 0.17 dB.
14. Press **PREV MENU**, **STORE DATA** and **YES** on the HP 8560E/EC.
15. Place the WR PROT/ WR ENA jumper on the A2 Controller assembly in the WR PROT position.

NOTE

The following steps should only be performed if you need to replace the 30 dB conversion loss values with those recorded in [Table 2-12 on page 112](#).

16. Press **AUX CTRL**, **EXTERNAL MIXER**, **AMPTD CORRECT**, then **CNV LOSS VS FREQ** on the HP 8560E/EC.
17. Press **▲** or **▼** to select frequencies where the conversion loss value was recorded in [Table 2-12 on page 112](#).
18. Use the spectrum analyzer front panel keys to enter the conversion loss values recorded for the frequency.

16. Signal ID Oscillator Adjustment (serial prefix 3517A and below)

Assembly Adjusted

A15 RF assembly

Related Performance Test

There is no related performance test for this adjustment.

Description

NOTE

This adjustment applies only to spectrum analyzers with A15 RF assembly 08563- 60083 or earlier (serial prefix 3517A and below). Later A15 RF assemblies have no 298 MHz adjustment. This procedure is required for spectrum analyzers with a serial prefix less than 3310A (standard and all options), or from 3310A through 3517A with Option 008 installed.

The frequency range of the 298 MHz signal ID oscillator is determined by counting the 10.7 MHz IF as A15C629 is rotated through its range of adjustment. The SIG ID oscillator is then set to the frequency determined by the following equation:

$$\text{Oscillator frequency} = 12.7 \text{ MHz} + \left(\frac{\text{Oscillator frequency range}}{4} \right)$$

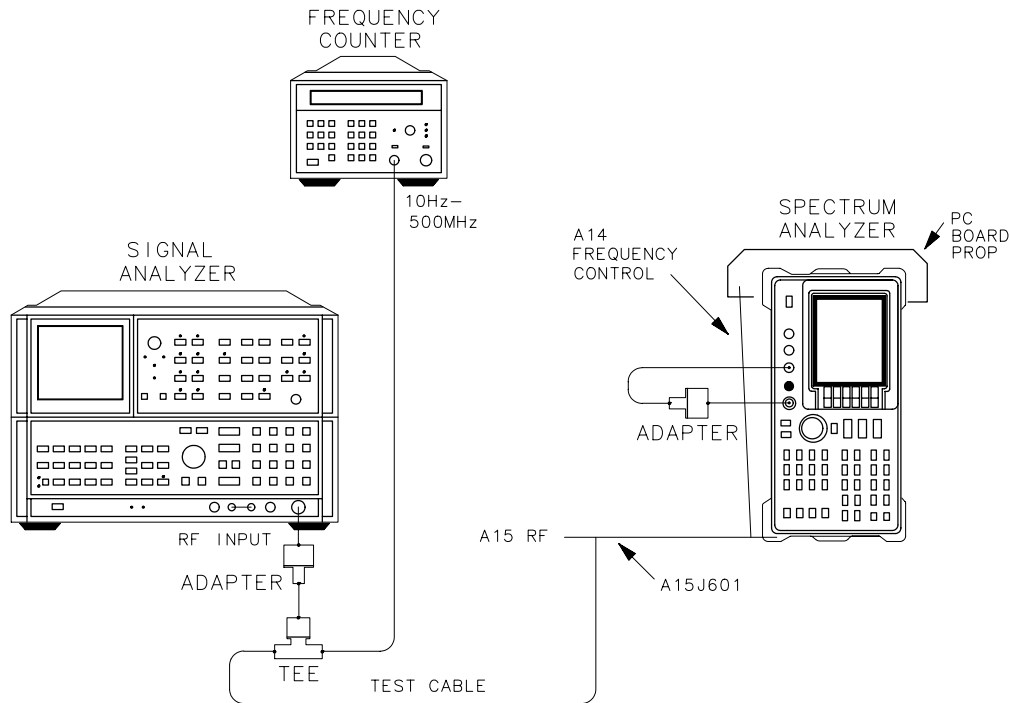
Figure 2-22 Signal ID Oscillator Adjustment Setup

SK119

Equipment

Microwave frequency counterHP 5343A
 Spectrum analyzer HP 8566A/B

Adapters

Type N (m) to BNC (f) (2 required) 1250-1476
 BNC tee (f, m, f)1250-0781

Cables

Test cable, BNC (m) to SMB (f) 85680-60093
 BNC, 122 cm (48 in) (2 required) HP 10503A

Procedure

1. Press **LINE** to turn the spectrum analyzer off, disconnect the power cord, and remove the spectrum analyzer cover. Fold down the A15 RF and A14 frequency control assemblies. Prop up the A14 frequency control assembly.
2. Connect the HP 8560E/EC CAL OUTPUT to the INPUT 50Ω using an adapter. Disconnect the W29 cable from A15J601 (10.7 MHz IF out) and connect the SMB end of the test cable to A15J601. Connect the rest of the equipment as shown in [Figure 2-22 on page 115](#).
3. Remove the four screws holding the brace on the A15 RF assembly (near J2).
4. Connect a jumper between the leads of A15R914 and A15C904 (the ends near U908). See [Figure 2-23 on page 116](#) for the location of the components.
5. Reconnect the power cord and press **LINE** to turn the spectrum analyzer on. After the power-on sequence is complete, set the HP 8560E/EC controls as follows:

Center frequency 300 MHz

Span 0 Hz

6. Press **CAL, IF ADJ ON OFF (OFF)**, and **SGL SWP**.

Figure 2-23 Signal ID Oscillator Adjustment Jumper Location

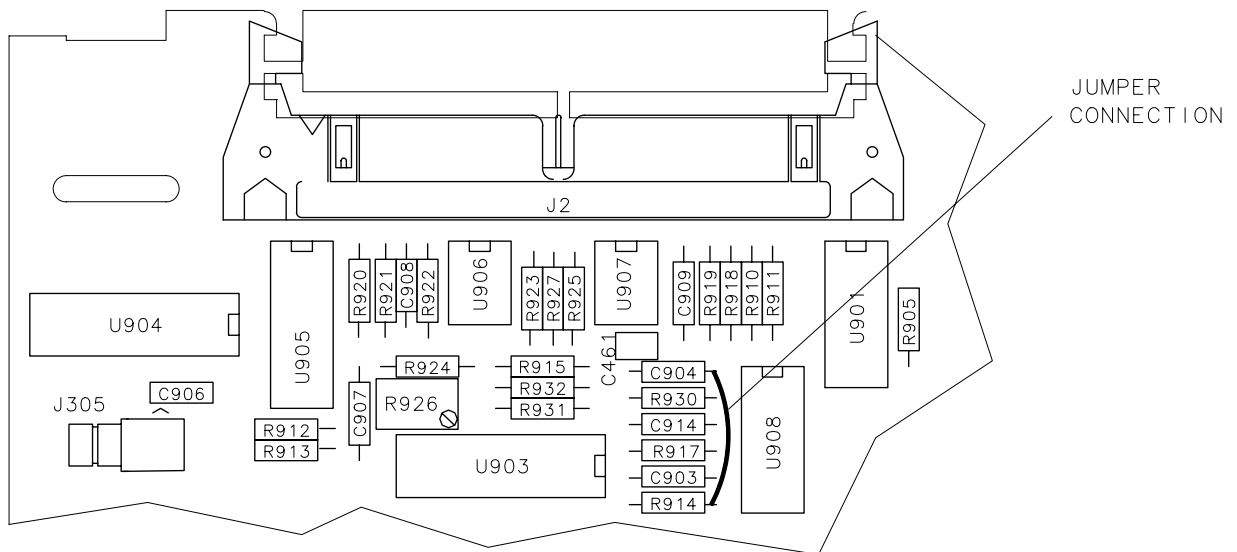

sp117e

16. Signal ID Oscillator Adjustment (serial prefix 3517A and below)

7. Press **INSTR PRESET** on the HP 8566A/B and set the controls as follows:

Center frequency 12.7 MHz
Span 500 kHz

8. Set the HP 5343A controls as follows:

Sample rate Fully counterclockwise
50 Ω — 1 M Ω SWITCH 50 Ω
10 Hz — 500 MHz/500 MHz — 26.5 GHz switch 10 Hz — 500 MHz

9. If no signal is displayed on the HP 8566A/B, adjust A15C629 SIG ID until a signal is displayed.

NOTE

If the 298 MHz SIG ID oscillator is severely mistuned, it might be necessary to widen the span on the HP 8566A/B to see the IF signal.

10. Rotate A15C629 SIG ID slightly while observing the HP 8566A/B display.

NOTE

The nominal counted frequency should be 12.7 MHz, not 10.7 MHz.

11. While observing the HP 8566A/B display, adjust A15C629 SIG ID for the highest obtainable frequency, with less than 3 dB decrease in amplitude from maximum. Read this frequency from the frequency counter and record as $F_{3 \text{ dB HIGH}}$.

$F_{3 \text{ dB HIGH}} =$ _____ MHz

12. Observe the HP 8566A/B display as you adjust A15C629 SIG ID for the lowest obtainable frequency, with less than 3 dB decrease in amplitude from maximum. Record the frequency counter reading as $F_{3 \text{ dB LOW}}$.

$F_{3 \text{ dB LOW}} =$ _____ MHz

13. Calculate the difference between $F_{3 \text{ dB HIGH}}$ and $F_{3 \text{ dB LOW}}$, then divide results by four. Enter the result as F_{OFFSET} .

$F_{\text{OFFSET}} =$ _____ kHz

14. Add F_{OFFSET} to $F_{3 \text{ dB LOW}}$ recorded in step 10 and record the result as F_{SIGID} .

$F_{\text{SIGID}} =$ _____ MHz

15. Adjust A15C629 for a frequency counter reading equaling F_{SIGID} . The final adjusted frequency must equal 12.7 MHz \pm 50 kHz.

17. 10 MHz Reference Adjustment-OCXO (Non-Option 103)

Assembly Adjusted

A21 OCXO assembly

NOTE

Replacement oscillators are factory adjusted after a complete warmup and after the specified aging rate has been achieved. Thus, readjustment should typically not be necessary after oscillator replacement and is generally not recommended.

Related Performance Test

10 MHz Reference Accuracy

Description

The frequency of the internal 10 MHz frequency reference is compared to a known frequency standard and adjusted for minimum frequency error. This procedure does not adjust the short-term stability or long-term stability of the A21 10 MHz ovenized crystal oscillator (OCXO). Stability is determined by the characteristics of the particular oscillator and the environmental and warmup conditions to which it has been recently exposed. The spectrum analyzer must be on continuously for at least 24 hours immediately prior to oscillator adjustment to allow both the temperature and frequency of the oscillator to stabilize.

Figure 2-24 10 MHz Reference Adjustment Setup and Adjustment Location

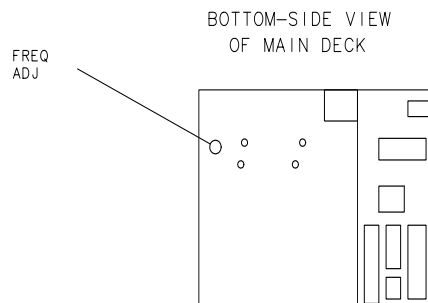
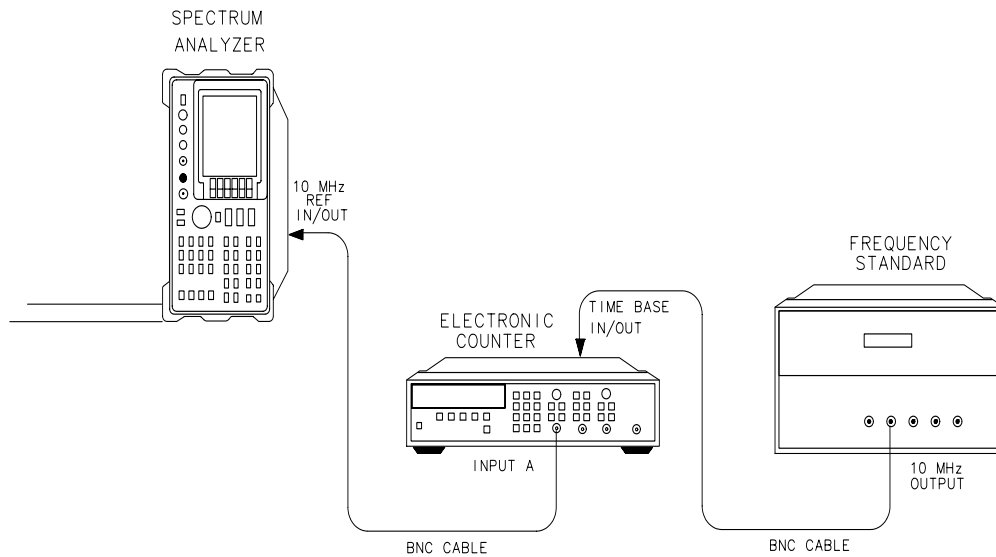

SK120

Equipment

Frequency counter HP 5334A/B
 Frequency standard..... HP 5061B Cesium Beam Standard
 (or any 10 MHz frequency standard with accuracy $<\pm 1 \times 10^{-10}$)

Cable

BNC, 122 cm (2 required)..... HP 10503A

Procedure

NOTE

Failure to allow a 24 hour minimum warmup time for OCXO frequency and temperature stabilization may result in oscillator misadjustment.

17. 10 MHz Reference Adjustment-OCXO (Non-Option 103)

1. Connect equipment as shown in [Figure 2-24 on page 119](#). Perform the following steps:
 - a. Press **LINE** to turn the spectrum analyzer on. After the automatic power-on adjustment sequence is complete, press **PRESET** to ensure that the frequency reference is set to internal.
 - b. Allow the spectrum analyzer to remain powered on continuously for at least 24 hours to ensure that the A21 OCXO temperature and frequency stabilize.

NOTE

If the reference is set to **10 MHz EXT**, press **10 MHz INT**. Allow the 24-hour warmup for the OCXO before continuing. When the 10 MHz reference is set to **10 MHz EXT**, the OCXO is not operating or warmed up.

- c. Connect the frequency standard to the frequency counter rear panel TIMEBASE IN/OUT connector.
 - d. Connect a BNC cable between the spectrum analyzer rear panel 10 MHz REF IN/OUT connector and INPUT A on the frequency counter.
2. Set the frequency counter controls as follows:

| | |
|--------------------------------|----------------------------|
| Function/data | freqA |
| Input | A |
| ×10 Attenuator | OFF |
| AC..... | OFF (DC coupled) |
| 50Ω | OFF (1 MΩ input impedance) |
| Auto trigger .. | ON |
| 100 kHz filter A .. | OFF |
| INT/EXT switch (rear panel) .. | EXT |
3. Select a 1 second gate time on the HP 5334A/B frequency counter by pressing **GATE TIME**, 1, and **GATE TIME**.
4. To offset the displayed frequency by -10.0 MHz, press **MATH SELECT/ENTER**, **CHX/EEX**, 10, **CHS/EEX**, 6, **SELECT/ENTER**, **SELECT/ENTER**. The frequency counter should now display the difference between the frequency of the INPUT A signal and 10.0 MHz with a displayed resolution of 0.010 Hz (10 MHz).
5. Locate the **FREQ ADJ** control on the HP 8560E/EC. This control is accessible through the center deck of the spectrum analyzer. See [Figure 2-24 on page 119](#).
6. Remove the dust-cap screw.
7. Use a nonconductive adjustment tool to adjust the **FREQ ADJ** control on the A21 OCXO for a frequency counter reading of 0.00 Hz.
8. On the HP 5334A/B frequency counter, select a 10-second gate time by pressing **GATE TIME**, 10, **GATE TIME**. The frequency counter should

now display the difference between the frequency of the INPUT A signal and 10.0 MHz with a resolution of 0.001 Hz (1 MHz).

9. Wait at least two gate periods for the frequency counter to stabilize, then adjust the FREQ ADJ control on A21 OCXO for a stable frequency counter reading of 0.000 Hz \pm 0.010 Hz.
10. Replace the dust-cap screw to A21 OCXO.

18. Tracking Oscillator Adjustment (Option 002)

NOTE This is *not* a routine adjustment. This adjustment should only be performed if there is insufficient tracking adjustment range.

Assembly Adjusted

A10 tracking generator assembly

Related Performance Test

Tracking Adjustment Range

Description

The centering of the tracking oscillator range is adjusted in the factory to ensure that the tracking adjustment functions properly. Over a period of 5 years, however, the center frequency of the tracking oscillator range may drift outside of acceptable limits. This adjustment should only be performed if there is insufficient tracking adjustment range.

This adjustment recenters the tracking oscillator range. The A10 tracking generator is partially removed from the spectrum analyzer to perform this adjustment. A synthesized sweeper is used as the first local oscillator signal. A frequency counter is used to measure the output frequency.

Equipment

Synthesized sweeper..... HP 8340A/B
Microwave frequency counter HP 5343A
50 Ω termination 1810-0118
Alignment tool, non-metallic ... 8710-0033

Cables

SMA, 91 cm (36 in) 5061-5458
BNC, 122 cm (48 in) (3 required) HP 10503A

Adapters

APC 3.5 (f) to APC 3.5 (f) 5061-5311 .
SMA (m) to BNC (f) 1250-1200
BNC tee 1250-0781

Procedure

1. Remove the A10 tracking generator assembly as described in Chapter 3. With the A10 tracking generator positioned next to the HP 8560E/EC, reconnect W14 (10-wire ribbon cable) to A10J1. Reconnect W48 to A10J8. Connect the 50 Ω termination to A10J3.
2. Connect the equipment as shown in Figure 2-25 on page 123. The frequency counter provides the frequency reference for the synthesized sweeper and the HP 8560E/EC.

Figure 2-25 Tracking Oscillator Adjustment Setup

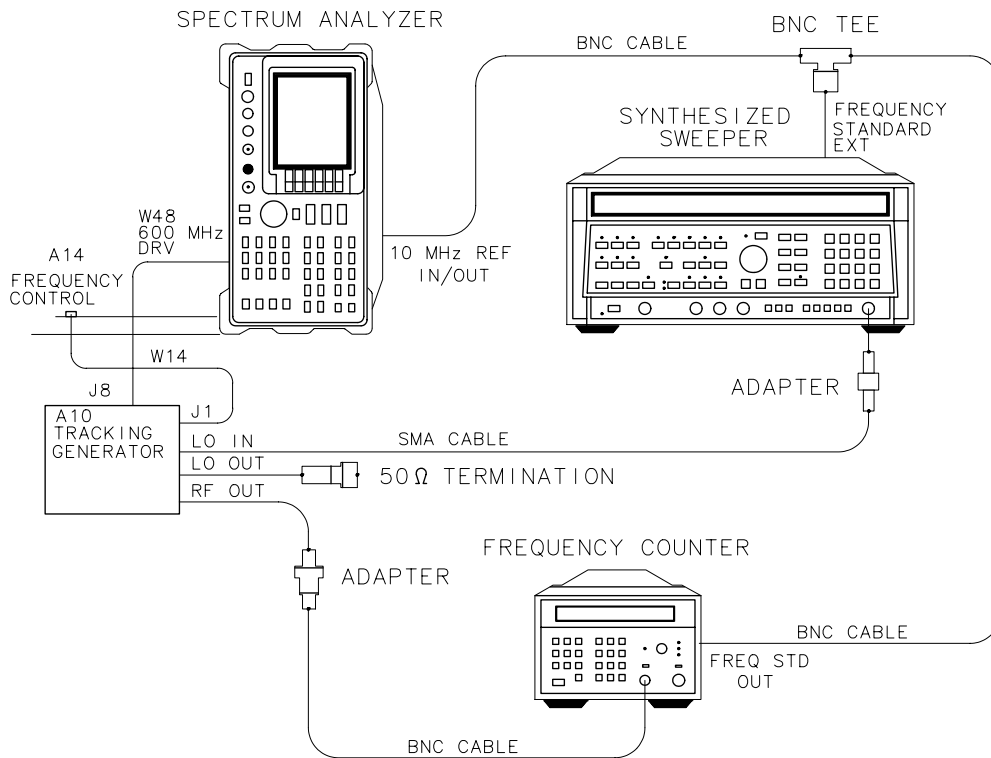

18. Tracking Oscillator Adjustment (Option 002)

- Press **LINE** to turn the spectrum analyzer on. Press **AUX CTRL**, **TRACKING GENERATOR**, **SRC PWR ON**, **AUX CTRL**, **REAR PANEL**, and **10 MHz EXT**. Allow the HP 8560E/EC to warm up for at least 5 minutes. Set the controls as follows:

Center frequency 300 MHz
Span..... 0 Hz

- Press **INSTR PRESET** on the synthesized sweeper and set the controls as follows:

CW 4.2107 GHz
Power level +12 dBm
Frequency standard switch (rear panel) EXT

- Set the frequency counter controls as follows:

SAMPLE RATE Fully CCW
10 Hz — 500 MHz / 500 MHz — 26.5 GHz Switch 10 Hz500 MHz
50 Ω — 1 MΩ Switch 50 Ω

- Remove the dust cap screw used to seal the tracking oscillator adjustment.
- On the HP 8560E/EC, press **AUX CTRL**, **TRACKING GENERATOR**, **MORE 1 OF 3**, **MAN TRK ADJ**, **0**, and **Hz**. Rotate the knob counterclockwise until **FINE TRACK ADJ** is set to 0.
- Record the frequency counter reading in [Table 2-13 on page 125](#) as F1.
- On the HP 8560E/EC, press **MAN TRK ADJ**, **255**, and **Hz**. Rotate the knob clockwise until the **FINE TRACK ADJ** is set to 255.
- Record the frequency counter reading in [Table 2-13 on page 125](#) as F2.
- Calculate F_{center} as shown below and record in [Table 2-13 on page 125](#).

$$F_{\text{center}} = (F1 + F2) / 2$$

- Set **COARSE TRACK ADJ** to 25. This sets the tracking oscillator near the center of its frequency range (the relationship between the **COARSE TRACK ADJ** dac number and the output frequency is nonlinear). Adjust **COARSE TRACK ADJ** and **FINE TRACK ADJ** until the frequency counter reads $F_{\text{center}} \pm 100$ Hz.
- Record the values of **COARSE TRACK ADJ** and **FINE TRACK ADJ** in [Table 2-13 on page 125](#).

14. Adjust A10C3 TRK OSC CTR until the frequency counter reads 300 MHz \pm 500 Hz.
15. Repeat steps 7 through 14 at least once more until no further adjustment of A10C3 TRK OSC CTR is necessary.
16. Press **LINE** to turn the spectrum analyzer off. Replace the dust cap screw on A10. Disconnect all cables from A10.
17. Reinstall A10 in the HP 8560E/EC.

Table 2-13**Tracking Oscillator Range Centering**

| N | F1 (MHz) | F2 (MHz) | F _{center} (MHz) | TRACK ADJ DAC Settings | |
|---|----------|----------|---------------------------|------------------------|------|
| | | | | COARSE | FINE |
| 1 | | | | | |
| 2 | | | | | |
| 3 | | | | | |
| 4 | | | | | |
| 5 | | | | | |

19. 16 MHz PLL Adjustment

| | |
|-------------|--|
| NOTE | This adjustment applies only to spectrum analyzers with A2 controller assemblies other than 08563-60017. |
|-------------|--|

Assembly Adjusted

A2 controller assembly

Related Performance Tests

Sweep Time Accuracy Gate Delay Accuracy and Gate Length Accuracy
Delayed Sweep Accuracy Fast Sweep Time Accuracy (Option 007)

Description

In spectrum analyzers with serial prefix numbers greater than or equal to 3310A, the 16MHz CPU clock is phase locked to the 10 MHz reference. The output of the 16 MHz PLL loop integrator is adjusted for a clock frequency of approximately 14.4 MHz with the loop unlocked. This ensures that the CPU will still function and the display annotation will be distorted but readable, even if the 10 MHz reference to A2 is absent.

| | |
|-------------|--|
| NOTE | If necessary, perform the display adjustments after performing the following adjustment. |
|-------------|--|

Figure 2-26 16 MHz PLL Adjustment Setup

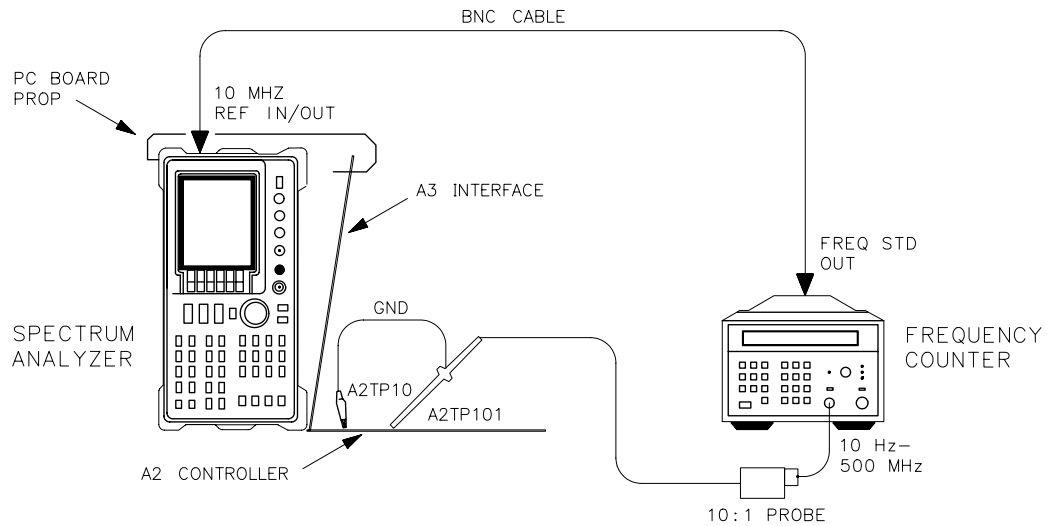

sj140e

Equipment

Microwave frequency counter HP 5343A
 10:1 probe HP 10432A

Procedure

1. Press **LINE** to turn the spectrum analyzer off. Remove the spectrum analyzer cover and fold out the A2 controller and A3 interface assemblies. Use a pc board prop to hold up the A3 interface assembly, as shown in [Figure 2-26 on page 127](#).
2. Connect the equipment as shown in [Figure 2-26 on page 127](#). The 10:1 probe ground lead connects to A2TP10 and the probe tip connects to A2TP101.
3. The 16 MHz PLL adjustment location is shown in [Figure 2-27 on page 128](#).

Figure 2-27 16 MHz PLL Adjustment Location

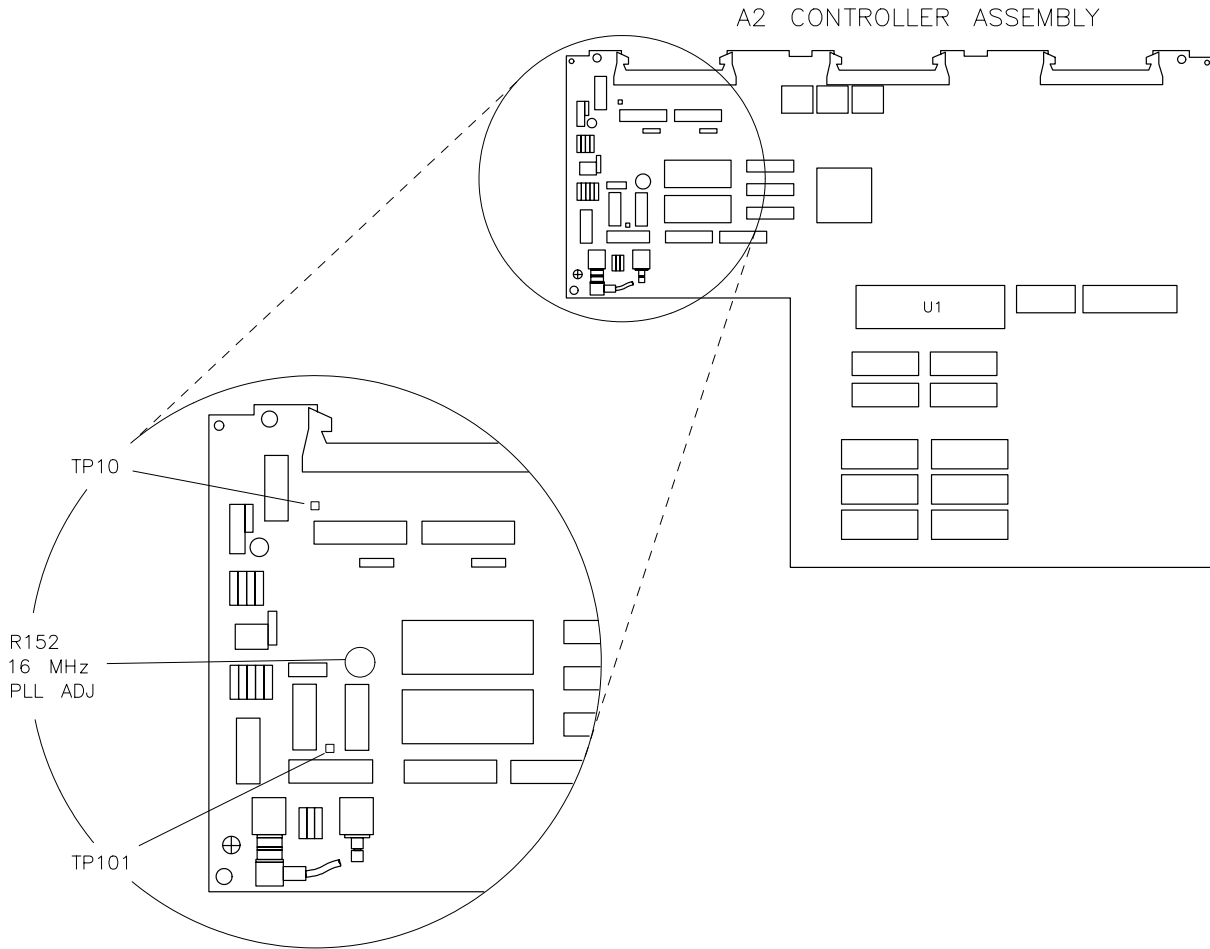

sj141e

4. Press **LINE** to turn the spectrum analyzer on. Wait until the spectrum analyzer power-on adjustments have completed.
5. Set the microwave frequency counter as follows:
Sample rate Fully counterclockwise
10 Hz — 500 MHz/500 MHz — 26.5 GHz Switch..... 10 Hz — 500 MHz
50 Ω /1 M Ω Switch 1 M Ω
6. On the HP 8560E/EC spectrum analyzer, press **AUX CTRL**, **REAR PANEL**, and **10 MHz EXT**.

7. Disconnect W22 (10 MHz frequency counter) from A2J8. The display will probably appear distorted and error messages may appear. Ignore the error messages.
8. Adjust A2R152 (16 MHz PLL ADJ) until the microwave frequency counter reads $14.4 \text{ MHz} \pm 200 \text{ kHz}$.
9. Reconnect W22 to A2J8. The microwave frequency counter should read 16 MHz. If the counter reads 16 MHz and the display is still distorted, perform the display adjustments in "Display Adjustment," in this chapter.
10. On the spectrum analyzer, press **CAL** and **REALIGN LO** and **IF** to clear any error messages.

20. 600 MHz Reference Adjustment (serial prefix 3406A and above)

Assembly Adjusted

A15 RF assembly

Related Performance Test

There is no related performance test for this adjustment.

Description

The 100 MHz VCXO and the tripler are adjusted for a maximum signal level at 600 MHz. A spectrum analyzer is used to monitor the amplitude of the 600 MHz signal while performing these adjustments.

Equipment

Spectrum analyzer HP 8566A/B.

Procedure

1. Press **LINE** to turn the spectrum analyzer off, disconnect the power cord, and remove the spectrum analyzer cover. Fold down the A15 RF and A14 frequency control assemblies. Prop up the A14 frequency control assembly.
2. Disconnect W33, gray/brown coax cable, from A15J701.
3. Connect the signal at A15J701 to the input of the HP 8566A/B spectrum analyzer.
4. Reconnect the power cord and press **LINE** to turn the spectrum analyzer on.
5. Set the center frequency of the HP 8566A/B to 600 MHz, and set the frequency span and resolution bandwidth of the HP 8566A/B for the best display of the 600 MHz signal.
6. Set the peak of the 600 MHz signal near the top graticule line on the HP 8566A/B display and set to 1 dB per division.
7. Adjust A15C750, VCXO Adjust, for maximum amplitude.
8. Adjust A15C751 Tripler Adjust, for maximum amplitude. The level, after proper adjustment, should be between -3 and $+4.8$ dBm (typically 0 to $+1$ dBm).
9. Reconnect W33 to A15J701.

2a **Adjustment Procedures:
HP 3335A Source not Available**

What You'll Find in This Chapter

This chapter provides alternative procedures for the adjustment of the spectrum analyzer that do not require the use of the HP 3335A Synthesizer Level Generator. The HP 3335A has been obsoleted. Because of the unavailability of the HP 3335A, new adjustment procedures are required that use different signal sources. If the HP 3335A is not available, substitute these procedures for those of the same number found in Chapter 2.

Required Test Equipment

The following table lists the test equipment required to execute the adjustments in this chapter. These adjustments originally required the use of the HP 3335A Synthesizer Level Generator.

Table 2a-1 Recommended Test Equipment

| Instrument | Critical Specifications for Equipment Substitution | Recommended Model |
|--|---|---|
| Sources | | |
| Synthesized Signal Generator | Frequency range: 250 kHz to 3 GHz Frequency resolution: 1 Hz Attenuator resolution: 0.02 dB Level accuracy: ± 0.5 dB External 10 MHz Ref. Input | HP E4421B or HP E4422B, HP E4432B, HP E4433B |
| Cables | | |
| Cable, 50 Ω coaxial <i>(four required)</i> | Connectors: BNC (m) Length: ≥ 122 cm (48 in.) | HP 10503A |
| Cable | Test Cable | 85680-60093 |
| Adapters | | |
| Adapter <i>(four required)</i> | Type N (m)-to-BNC (f) | 1250-1476 |
| Adapter <i>(Option 026 only)</i> | APC-3.5 (f) to APC-3.5 (f) | 5061-5311 |
| Adapter <i>(Option 026 only)</i> | APC-3.5 (f) to BNC-3.5 (f) | 1250-1200 |

4a. IF Amplitude Adjustments

The IF Amplitude Adjustments consist of the Cal Oscillator Amplitude adjustment and the Reference 15 dB Attenuator adjustment.

Assembly Adjusted

A4 log amp/cal oscillator A5 IF assembly

Related Performance Tests

IF Gain Uncertainty Scale Fidelity

Equipment

Signal Generator HP E4421B

Adapters

Type N (m) to BNC (f) 1250-1476

Cables

BNC, 122 cm (48 in) HP 10503A

Test cable 85680-60093

Figure 2a-1 IF Amplitude Adjustment Setup

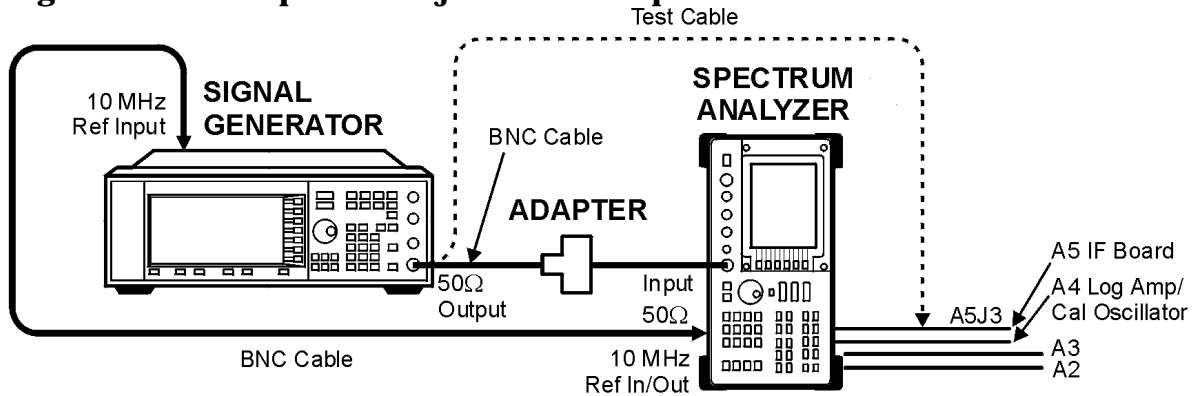

hj12e

Figure 2a-2 IF Amplitude Adjustment Locations

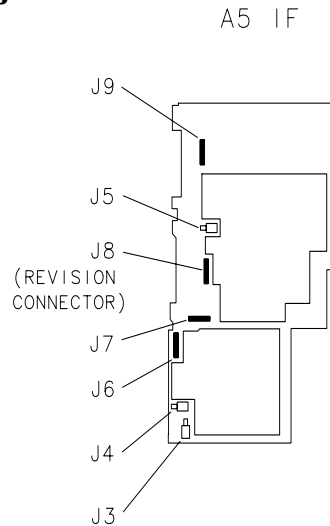

sj115c

A4 Log Amp/Cal Oscillator Amplitude Adjustment

This adjustment sets the output amplitude of the cal oscillator on the A4 assembly, and the absolute amplitude of the reference 15 dB attenuator.

The output of the cal oscillator is adjusted so that a -55 dBm signal applied to the 10.7 MHz IF input on the A5 IF assembly (A5J3) causes a displayed signal of -60 dBm. The effect of this adjustment is visible only after the **ADJ CURR IF STATE** sequence is complete.

ADJ CURR IF STATE causes the IF gain adjustment to use the “new” output amplitude from the cal oscillator. When the adjustment sequence is complete, the result of the adjustment should cause the -35 dBm signal at A5J5 to be displayed at -60 dBm.

This procedure also sets the attenuator of the reference 15 dB attenuator so that a source amplitude change of 50 dB combined with a spectrum analyzer reference level change of 50 dB displays an amplitude difference of 50 dB.

NOTE

The 15 dB reference attenuator adjustment is preset at the factory and need not be done if the entire A5 IF assembly is replaced.

Procedure

1. Press **LINE** to turn the spectrum analyzer off. Remove the spectrum analyzer cover and place the spectrum analyzer in the service position as illustrated in Figure 2a-1. See Figure 2a-2 for adjustment location.
2. Disconnect W29, violet coax cable, from A5J3. Connect the test cable between A5J3 and the RF output of the HP E4421B. Press **LINE** to turn the spectrum analyzer on.

3. Set the spectrum analyzer controls as follows:

Center frequency 10.7 MHz
Span 200 kHz
Reference level -60 dBm
Attenuator 0 dB
Log/division. 1 Log/division
Resolution BW 300 kHz
Video BW 100 Hz

4. On the spectrum analyzer, press **MKR**, **CAL**, and **IF ADJ OFF**.
5. Set the HP E4421B controls as follows:
Frequency 10.7 MHz
Amplitude -55 dBm
Mod On/Off Off
6. Note the marker value. Ideally it should read -60 dBm \pm 0.1 dB.
7. If the marker reads less than -60.1 dBm, rotate A4R826 CAL OSC AMPTD one-third turn counter-clockwise for every 0.1 dB less than -60 dBm. See Figure 2a-2 for the location of A4R826.
8. If the marker reads greater than -59.9 dBm, rotate A4R826 CAL OSC AMPTD one-third turn clockwise for every 0.1 dB greater than -60 dBm. A change in the displayed amplitude will not be seen at this point.

NOTE

If A4R826 has inadequate range, refer to "Inadequate CAL OSC AMPTD Range" in Chapter 9.

9. On the spectrum analyzer, press **ADJ CURR IF STATE**. After allowing the spectrum analyzer time to complete the adjustments, the displayed amplitude and marker reading should change.

10. Repeat [step 7](#) through [step 9](#) until the marker reads -60 dBm ± 0.1 dB.
11. Disconnect the test cable from A5J3 and reconnect W29 to A5J3.

A5 Reference Attenuator Adjustment

1. Set the HP E4421B **AMPLITUDE** to -60 dBm.
2. Connect a BNC cable between the RF output of the HP E4421B and the spectrum analyzer INPUT 50Ω
3. On the spectrum analyzer, press **CAL** and **REF LEVEL ADJUST**. Use the front panel knob or step keys to place the peak of the displayed signal 3 dB to 5 dB below the reference level.
4. On the spectrum analyzer, press **PEAK SEARCH** and **MARKER DELTA**. Set the spectrum analyzer reference level to -10 dBm.
5. Change the HP E4421B **Amplitude** to -10 dBm.
6. On the spectrum analyzer, press **CAL**.
7. Note the Δ MKR amplitude. Ideally, it should read 50.00 dB ± 0.1 dB.
8. If the Δ MKR amplitude is less than 49.9 dB, rotate A5R343 (15 dB ATTEN) one-half turn counterclockwise for each 0.1 dB less than 50.00 dB. If the Δ MKR amplitude is greater than 50.1 dB, rotate A5R343 one-half turn clockwise for each 0.1 dB greater than 50.00 dB. Do not adjust A5R343 more than five turns before continuing with the next step.
9. On the spectrum analyzer, press **ADJ CURR IF STATE**. Note the Δ MKR amplitude reading.
10. Set the spectrum analyzer reference level to -60 dBm and press **MKR** and **MARKERS OFF**.
11. Repeat [step 1](#) through [step 10](#) until the Δ MKR amplitude reading is 50.00 dB ± 0.1 dB.

A5 Adjustment Verification

1. On the spectrum analyzer, disconnect W29 from A5J3. Connect the test cable between A5J3 and the RF output of the HP E4421B.
2. Set the spectrum analyzer reference level to -10 dBm.
3. Set the HP E4421B **Amplitude** to -5 dBm.
4. On the spectrum analyzer press **MKR** and **MARKER NORMAL**.
5. The **MARKER** amplitude should read -10 dBm ± 0.13 dB. If the reading is outside of this range, repeat [step 3, on page 2a-136](#) through [step 10, on page 2a-137](#).

4a. IF Amplitude Adjustments

6. On the spectrum analyzer, reconnect W29 to A5J3. Press **PRESET** and set the controls as follows:

Center frequency 300 MHz

Span 0 Hz

Reference level -10 dBm

Resolution BW 300 kHz

7. Connect a BNC cable between the spectrum analyzer CAL OUTPUT and INPUT 50Ω
8. On the spectrum analyzer, press **MKR**, **CAL**, and **REF LVL ADJ**.
9. Use the knob or step keys to adjust the REF LEVEL CAL setting until the MKR reads -10.00 dBm ±0.1 dB.
10. On the spectrum analyzer, press **STORE REF LVL**.

5a. DC Log Amplifier Adjustments

There are three DC Log adjustments; Limiter Phase, Linear Fidelity, and Log Fidelity.

These adjustments need only be done under the following conditions:

Limiter Phase Only if a repair is made to blocks F, G, H, I, or J.

Linear Fidelity Only if a repair is made to blocks C, D, F, G, H, I, J, K, O, IF Gain Accuracy, RBW switching, or Log Fidelity.

Log Fidelity Only if a repair is made to blocks D, F, H, K, IF Gain Accuracy, RBW switching, or Log Fidelity.

If multiple adjustments are required, they should be done in the following order:

1. Limiter Phase
2. Linear Fidelity
3. Log Fidelity

All adjustments should be made with all of the shields on and only after allowing at least a 20 minute warmup.

Assembly Adjusted

A4 log amplifier

Related Performance Tests

IF Gain Uncertainty Scale Fidelity

Equipment

Signal Generator HP E4421B

Adapters

Type N (m) to BNC (f) 1250-1476

Cables

BNC, 122 cm (48 in)HP 10503A

Test cable 85680-60093

Figure 2a-3 IF Amplitude Adjustment Setup

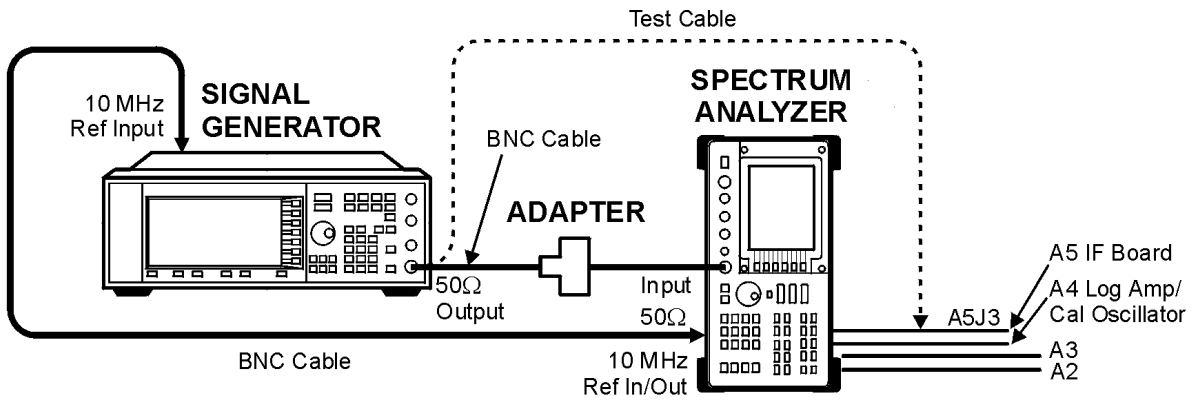

hj12e

Figure 2a-4 IF Amplitude Adjustment Locations

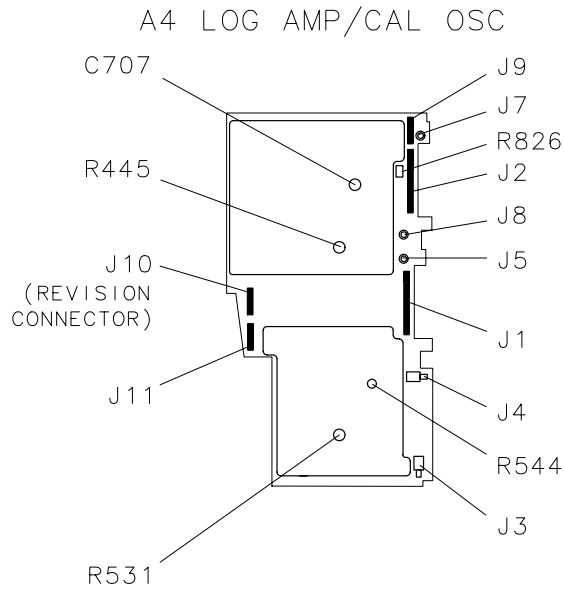

sj116c

A4 Limiter Phase Adjustment

This adjustment consists of adjusting A4R445 for maximum on screen amplitude under the following conditions.

Procedure

1. Press **LINE** to turn the spectrum analyzer off. Remove the spectrum analyzer cover and place the spectrum analyzer in the service position as illustrated in Figure 2a-3. See Figure 2a-4 for adjustment location.
2. Connect the HP E4421B RF output to the spectrum analyzer 50 Ω input. Press **LINE** to turn the spectrum analyzer on.
3. Set the spectrum analyzer controls as follows:
Center frequency 15 MHz
Span 0 kHz
Reference level -10 dBm
Log/division. 1 Log/division
Resolution BW 300 kHz
IF Adjust. off
4. Set up an HP E4421B as follows:
Frequency 15 MHz
Amplitude -18 dBm
Mod On/Off Off
5. On the spectrum analyzer, press **CAL** and **ADJ CURR IF STATE**, wait for the spectrum analyzer to complete adjustments, then press **MKR**.
6. Adjust A4R445 for maximum on-screen amplitude. Refer to Figure 2a-4 for the location of A4R445.

A4 Linear Fidelity Adjustment

This adjustment consists of adjusting A4R544 until the delta marker reads -40 dB under the following conditions.

Procedure

1. Press **LINE** to turn the spectrum analyzer off. Remove the spectrum analyzer cover and place the spectrum analyzer in the service position as illustrated in Figure 2a-3. See Figure 2a-4 for adjustment location.
2. Connect the HP E4421B RF output to the spectrum analyzer 50 Ω input. Press **LINE** to turn the spectrum analyzer on.
3. On the spectrum analyzer, press **PRESET**, **AMPLITUDE**, **LINEAR**, **MORE 1 of 3**, **AMPD UNITS**, **dBm**, **CAL**, and **IF ADJ OFF**.
4. Set the spectrum analyzer controls as follows:
 - Center frequency 15 MHz
 - Span 5 MHz
 - Resolution BW 300 kHz
 - Reference level -10 dBm
5. Set up an HP E4421B as follows:
 - Frequency 15 MHz
 - Amplitude -18 dBm
 - Mod On/Off Off
6. On the spectrum analyzer, press **PEAK SEARCH** and **MARKER DELTA**.
7. Reduce the input power by 40 dB, to -58 dBm (use an attenuator or a source with a good relative amplitude accuracy).
8. If the signal is lower on the screen than expected (delta marker reads a change of greater than 40 dB, such as -41dB), then adjust A4R544 (see Figure 2a-4) for an even lower level and press **CAL** and **ADJ CURR IF STATE**. Allow sufficient time for the spectrum analyzer to complete the adjustment.
9. If the signal is higher on the screen than expected (delta marker reads a change of less than 40 dB, such as reads -39 dB), then adjust A4R544 for an even higher level signal and press **CAL** and **ADJ CURR IF STATE**. Allow sufficient time for the spectrum analyzer to complete the adjustment.
10. Repeat the adjustment and adjust current state until the delta marker reads -40 dB \pm 2 dB.

A4 Log Fidelity Adjustment

This adjustment consists of adjusting A4R531 until the error is adjusted to zero.

Procedure

1. Press **LINE** to turn the spectrum analyzer off. Remove the spectrum analyzer cover and place the spectrum analyzer in the service position as illustrated in Figure 2a-3. See Figure 2a-4 for adjustment location.
2. Connect the HP E4421B RF Ω output to the spectrum analyzer 50 Ω input. Press **LINE** to turn the spectrum analyzer on.
3. On the spectrum analyzer, press **PRESET**, **CAL**, **IF ADJ OFF**, and **ADJ CURR IF STATE**.
4. Set the spectrum analyzer controls as follows:
Center frequency 15 MHz
Span 0
Resolution BW 300 kHz
Reference level -10 dBm
5. Set up an HP E4421B as follows:
Frequency 15 MHz
Amplitude -10 dBm
6. On the spectrum analyzer, press **MKR** and **MARKER DELTA**, then decrease the source power to -26 dBm.
7. Calculate the error. The error = Delta Marker reading + 16 (in dB).
8. Set the source power to -10 dBm.
9. Adjust A4R531 (see Figure 2a-4) to read 2 times the error, press **CAL** and **ADJ CURR IF STATE**.
10. Repeat to check. Readjust as necessary to get error adjusted to zero.

3 **Assembly Replacement**

Introduction

This chapter describes the removal and replacement of all major assemblies. The following replacement procedures are provided:

| | |
|---|----------|
| Access to Internal Assemblies | page 147 |
| Cable Color Code | page 148 |
| Procedure 1. Spectrum Analyzer Cover | page 149 |
| Procedure 2A. A1 Front Frame/A18 LCD (8560EC) | page 150 |
| W3 Line Switch Cable (8560EC) | page 153 |
| Procedure 2B. A1 Front Frame/A18 CRT (8560E) | page 160 |
| Procedure 3. A1A1 Keyboard/Front Panel Keys..... | page 169 |
| Procedure 4. A1A2 RPG..... | page 170 |
| Procedure 5. A2, A3, A4, and A5 Assemblies..... | page 171 |
| Procedure 6A. A6 Power Supply Assembly (8560EC) | page 178 |
| Procedure 6B. A6 Power Supply Assembly (8560E)..... | page 181 |
| Procedure 7. A6A1 High Voltage Assembly (8560E)..... | page 185 |
| Procedure 8. A7 through A13 Assemblies..... | page 189 |
| A7 1st LO Distribution Amplifier..... | page 191 |
| A8 Low Band Mixer | page 192 |
| A9 Input Attenuator | page 192 |
| A10 Tracking Generator (Option 002) | page 194 |
| A11 YTO | page 195 |
| A13 Second Converter..... | page 196 |
| Procedure 9. A14 and A15 Assemblies..... | page 197 |
| Procedure 10. A16 FADC/A17 CRT Driver (8560E) | page 200 |
| Procedure 11. B1 Fan..... | page 203 |
| Procedure 12. BT1 Battery | page 204 |
| Procedure 13. Rear Frame/Rear Dress Panel..... | page 205 |
| Procedure 14. W3 Line Switch Cable (8560E) | page 210 |
| Procedure 15. EEROM (A2U501)..... | page 219 |
| Procedure 16. A21 OCXO (Non-Option 103)..... | page 221 |

Tools required to perform the procedures are listed in [Table 3-1 on page 148](#).

The words *right* and *left* are used throughout the replacement procedures to indicate the side of the spectrum analyzer as viewed from the front panel. See [Figure 3-1 on page 149](#).

Numbers in parentheses are used throughout the replacement procedures to indicate numerical callouts on the figures.

CAUTION

The spectrum analyzer contains static-sensitive components. Read the section entitled, "Electrostatic Discharge" in Chapter 1.

Access to Internal Assemblies

Servicing the HP 8560E/EC requires the removal of the spectrum analyzer cover assembly and the folding down of six board assemblies. Four of these assemblies lay flat along the top of the spectrum analyzer and two lay flat along the bottom of the spectrum analyzer. All six assemblies are attached to the spectrum analyzer right side frame using hinges and fold out of the spectrum analyzer allowing access to all major assemblies. See [Figure 3-1 on page 149](#).

- To remove the spectrum analyzer cover assembly, refer to procedure 1.
- To access the A2, A3, A4, and A5 assemblies, refer to procedure 5.
- To access the A14 and A15 assemblies, refer to procedure 9.
- To remove and replace the backlight cables, which illuminate the A18 LCD, refer to procedure 2A.
- To remove A17 LCD assembly, refer to procedure 2A.
- To remove A16 or A17, refer to procedure 10.

NOTE

Diagrams that illustrate features common to E-series and EC-series instruments are shown with E-series instruments. Where there are differences between E-series and EC-series features, separate diagrams are provided for E-series and for EC-series instruments.

Cable Color Code

Coaxial cables and wires will be identified in the procedures by reference designation, or name, followed by a color code. The code is identical to the resistor color code. The first number indicates the base color with second and third numbers indicating any colored stripes. For example, W23, coax 93, indicates a white cable with an orange stripe.

Table 3-1

Required Tools

| Description | HP Part Number |
|--|----------------|
| 5/16-inch open-end wrench | 8720-0015 |
| 3 mm hex (Allen) wrench | 8710-1366 |
| 4 mm hex (Allen) wrench | 8710-1164 |
| 17 mm hex (Allen) wrench | T362609 |
| No. 6 hex (Allen) wrench | 5020-0289 |
| 7 mm nut driver | 8710-1217 |
| 3/8-inch nut driver | 8720-0005 |
| 7/16-inch nut driver | 8720-0006 |
| 9/16-inch nut driver (drilled out, end covered with heatshrink tubing) | 8720-0008 |
| Small No.1 pozidrive screwdriver | 8710-0899 |
| Large No.2 pozidrive screwdriver | 8710-0900 |
| T-8 TORX screwdriver | 8710-1614 |
| T-10 TORX screwdriver | 8710-1623 |
| T-15 TORX screwdriver | 8710-1622 |
| Long-nose pliers | 8710-0030 |
| Wire cutters | 8710-0012 |

Procedure 1. Spectrum Analyzer Cover

Removal/Replacement

1. Disconnect the line-power cord, remove any adapters from the front panel connectors, and place the spectrum analyzer on its front panel.
2. If an HP 85620A Mass Memory Module or HP 85629B Test and Adjustment Module is mounted on the rear panel, remove it. Loosen (but do not remove) the four rear-bumper screws, using a 4 mm hex wrench. Pull the cover assembly off towards the rear of the instrument.

CAUTION

When replacing the spectrum analyzer cover, use caution to avoid damaging any cables.

3. When installing the cover assembly, be sure to locate the cover air vent holes on the bottom side of the spectrum analyzer. Attach with the four screws loosened in step 2, and tighten the four screws gradually to ensure that the cover is seated in the front frame gasket groove.
4. Torque each screw to 40 to 50 inch-pounds to ensure proper gasket compression to minimize EMI.

Figure 3-1 Hinged Assemblies

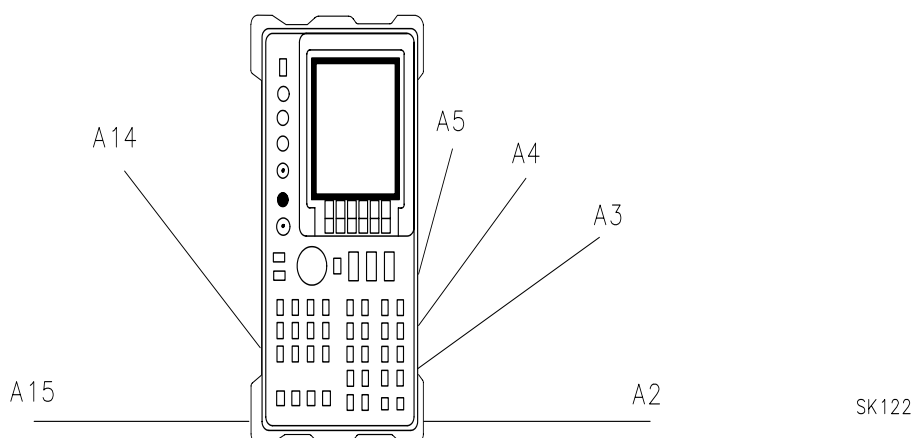

NOTE

Figure 3-1 shows an 8560 E-series instrument. In the assembly removal and replacement procedures the words “left” and “right” assume you are facing the front panel of the instrument, as shown in Figure 3-1, with A14 and A15 to your left, and A2 through A5 on your right. The 8560 EC-series instrument is identical except the A2 board is smaller.

Procedure 2A. A1 Front Frame/A18 LCD (8560EC)

Removal of the Front Frame

1. Remove the spectrum analyzer cover assembly as described in "Procedure 1. Spectrum Analyzer Cover." Place the instrument on its side, with the display section upper-most, as shown in [Figure 3-1 on page 149](#).
2. Fold out the A2, A3, A4, and A5 assemblies as described in steps 2 through 6 under "Procedure 5. A2, A3, A4, and A5 Assemblies Removal." Facing the front panel, the A2, A3, A4, and A5 assemblies will lay to your left.
3. Fold out the A14 and A15 assemblies as described in steps 3 through 4 under "Procedure 9. A14 and A15 Assemblies". Facing the front panel, the A14 and A15 assemblies will lay to your right.
4. Disconnect ribbon cable A1A1W1, which connects HDR1 on the A1 front frame assembly and A3J602 on the A3 interface board.
5. Disconnect the following cables from the A2 controller board:
 - a. Ribbon cable W60, which connects J8 on the A2 controller board with J1 on the A17 display driver board.
 - b. W61, which connects J9 on the A2 controller board with J7 on the A17 display driver board.
6. Disconnect ribbon cable W64 from the J1 VGA port on the rear panel (do not disconnect W64 from the A17 display driver board).
7. Disconnect the W3 line switch cable from the power supply.
 - a. Remove the power supply cover. Use a T-6 TORX driver to remove the 3 screws (0515-2309) that secure the power supply cover to the power supply.
 - b. Remove the line switch connector from A6J2 on the power supply.
 - c. Loosen FL 1. Remove the two screws (0515-2332) which are used to secure FL 1 to the right side of the chassis.
 - d. After FL 1 has been loosened, route the W3 line switch cable through the opening behind FL 1, from the left to the right side of the instrument (if you still have difficulty routing W3 through the opening, use an open ended 5/16-inch wrench to further loosen, or disconnect FL 1).

To disconnect the line switch from the front panel, see Removal of the Line Switch from the Front Panel on [page 153](#).

8. Disconnect the following connectors which are attached to the inside of the A1 front panel assembly:
 - a. INPUT 50 Ω RF connector. Use a 5/16-inch open-end wrench to disconnect cable W41 from the front panel. Loosen the opposite end of cable W41, which is connected to the attenuator.
 - b. RF OUT 50 Ω connector *for Option 002 spectrum analyzers*. Use a 5/16-inch wrench to disconnect cable W47 from the front panel.
 - c. 1ST LO OUTPUT connector. Disconnect cable W42 from A7J3 and from the front panel 1st LO OUTPUT connector.

To remove the 1st LO OUTPUT connector use a 5/16 socket and thread pliers. Use the pliers to hold the 1st LO connector in place, while loosening the connector inside the instrument with the 5/16-inch socket.
 - d. 1ST LO OUTPUT connector *For Option 002 spectrum analyzers*. Disconnect W46 from the front panel.
 - e. IF INPUT connector. Disconnect W36 from the front panel.

9. Remove the following from the face of the front panel:
 - a. VOLUME knob. Use a 0.050 Allen wrench to remove the two screws (3030-0007) that secure the volume knob to the face of the front panel. If necessary, use a 5/16-inch nut driver to drill out the nut which secures the VOLUME potentiometer assembly. Cover the tip with heatshrink tubing or tape to avoid scratching the enameled front panel.
 - b. CAL OUTPUT connector. Use a 9/16-inch nut driver to remove the dress nut that holds the front panel CAL OUTPUT connector to the front panel. If necessary, drill out the nut driver to fit over the BNC connectors and cover the tip with heatshrink tubing or tape to avoid scratching the enameled front panel.

10. Remove the front frame from the chassis of the instrument.
 - a. Remove the screw (0515-1227) that secures the top of the attenuator to the inside of the front frame of the instrument.
 - b. Remove the three screws (0515-1101) that secure the A1 front frame assembly to the bottom of the spectrum analyzer.
 - c. Remove the three screws (0515-1101) that secure the A1 front frame assembly to the top of the spectrum analyzer.
 - d. Remove the A1 front frame assembly from the chassis.

Note that the line switch cable is still attached to the front frame. To remove the line switch you must first remove the display driver and LCD assembly. For instructions on removing the line switch, see [“Removal of the Line Switch from the Front Panel” on page 153.](#)

Removal of the Display Driver Board, Inverter Board, and LCD

After the front panel has been removed, follow these steps to remove the display driver and LCD:

1. Disconnect the following cables from the A17 display driver board. These can be disconnected through openings in the display driver shield. See [Figure 3-2 on page 154](#).
 - a. W60, a ribbon cable that connects J1 on the A17 display driver board with J8 on the A2 controller board.
 - b. W61, which connect J7 on the A17 display driver board with J9 on the A2 controller board.
2. Remove the four screws (0515-0665) that secure the display driver shield to the LCD backplate. Use a T-10 TORX driver set to 6 in./lbs. Remove the display driver shield.
3. Disconnect the following cables from the A17 display driver board:
 - a. W64, the VGA ribbon cable, which connects J4 on the A17 display driver board to J1 on the rear panel.
 - b. W63, a ribbon cable that connect J5 on the A17 display driver board with the LCD.
4. If you want to remove the A17A1 inverter board, proceed to step a. If you intend to keep the A17A1 inverter board secured to the A17 display driver board, proceed to step 4.
 - a. Remove the two screws (0515-0430) which secure the A17A1 inverter board to standoffs on the A17 display driver board.
 - b. Disconnect W62 from J6 on the A17 display driver board (do not disconnect W62 from the A17A1 inverter board, to which it is attached).
5. Remove the two backlight cables from the inverter board.
6. Remove the four screws (0515-0372) which secure the display driver board to the LCD backplate. Use a T-10 TORX driver. Remove the display driver board.
7. Remove four black cushions (0400-0333) from the inner-most posts on the LCD backplate.
8. Remove the two large screws (0515-0382) which secure the LCD backplate to the left side of the front panel chassis. Use a T-15 TORX driver.
9. Remove the four (0515-0430) screws which secure the LCD backplate to the right side of the front panel chassis. Use a T-8 TORX driver.

10. Carefully lift the display driver backplate over the two backlight cables and the W63 ribbon cable.
11. Remove the LCD assembly from the black rubber mount. Take care not to damage the backlight cables or W63 ribbon cable.
12. To remove the glass plate, first remove the LCD display from the display mount. Carefully remove the glass from the inside of the display mount.

NOTE

The LCD glass plate was originally placed in the LCD assembly in a clean room environment to ensure optimal performance of the LCD display. Take all possible precautions to ensure that the glass plate is clean before replacing it in the LCD assembly.

Removal of the Backlights

1. Remove the LCD assembly by following steps 1 through 12 in [“Removal of the Display Driver Board, Inverter Board, and LCD”](#) on page 152.
2. Remove each backlight cable assembly (2090-0380). *Carefully* grasp the end of the metal backlight assembly, which is connected to the backlight cable, and pull the backlight out from its slot. The backlight cable slots are located at the top and at the bottom of the LCD.

NOTE

Whenever there is a need to replace a single backlight, both backlights must be replaced.

Removal of the Line Switch from the Front Panel

After the A1 front frame assembly, the A17 display driver, and the A18 LCD have been removed, you can proceed to remove the line switch. Follow these steps:

1. Remove the green LED from the line switch assembly on the front frame, by gently pulling on the orange and black cables (wrapped in shrink tubing), to which the LED is connected.
2. Remove the two screws (0515-1521) that secure the line switch to the front frame.
3. Remove the screw (0515-0430) that secures the striped green and white ground cable to the line switch.
4. Remove the line switch from the front panel.

Figure 3-2 LCD Assembly - Exploded View

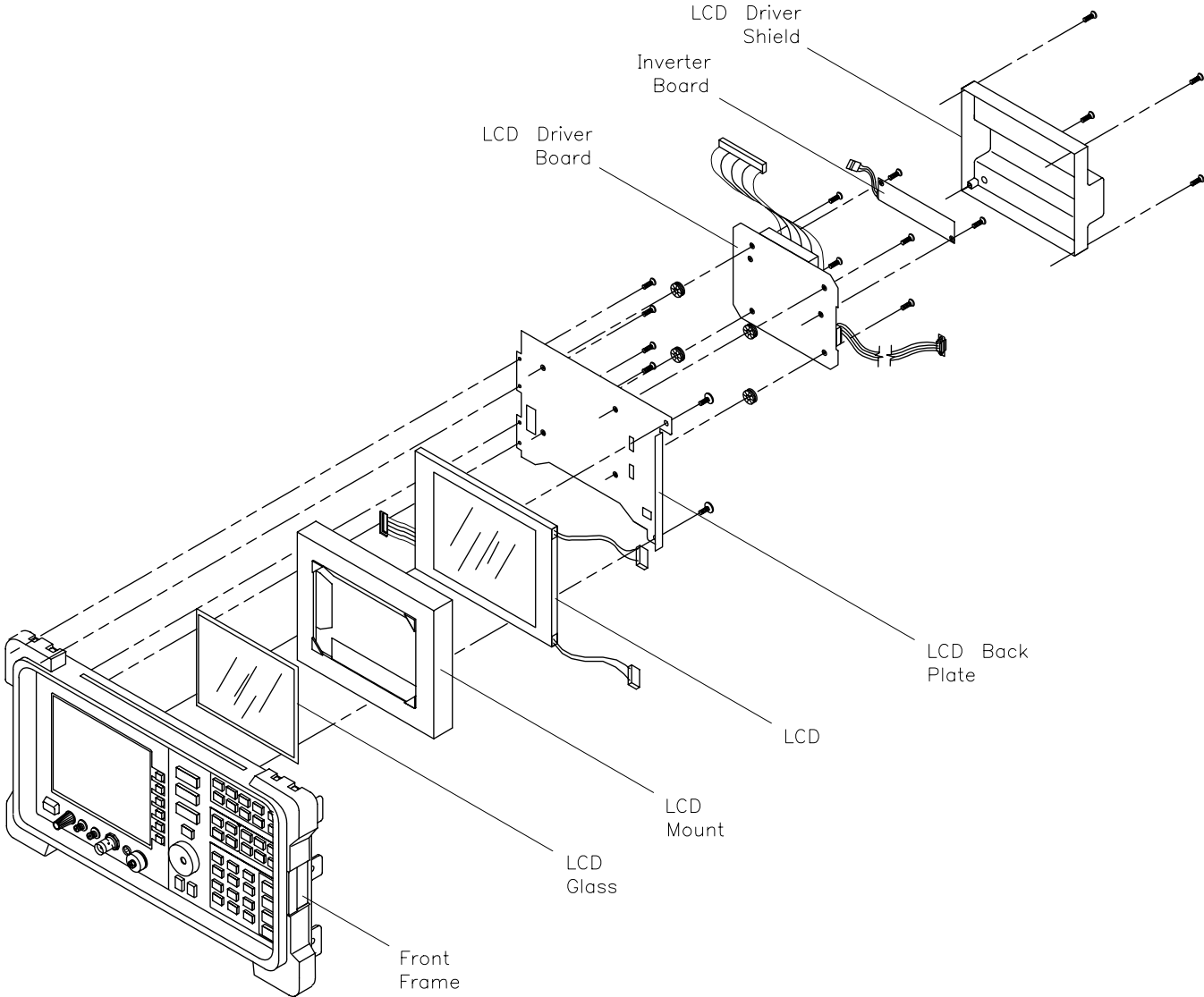

s1135c

Removal of the Keyboard

1. Disconnect cable A1A1W1 from HDR1 on the A1 front panel assembly and from A3J602 on the A3 interface board.
2. Disconnect the power probe cable from the probe power connector on the front frame PC board.
3. Unhook the RPG cable.
4. Remove the seven screws (0515-1934) that secure the front frame PC board to the front frame. Use a T-8 TORX driver set to 6-in/lbs.

Replacement of the Front Frame

1. Remove the cover assembly as described in "Procedure 1. Spectrum Analyzer Cover." Place the instrument on its side, with the display section upper-most, as shown in [Figure 3-1 on page 149](#).
2. Fold out the A14 and A15 assemblies as described in steps 3 through 4 under "Procedure 9. A14 and A15 Assemblies". Facing the front panel, the A14, and A15 assemblies will lie to your right.
3. Fold out the A2, A3, A4, and A5 assemblies as described in steps 2 through 6 under "Procedure 5. A2, A3, A4, and A5 Assemblies Removal." Facing the front panel, the A2, A3, A4, and A5 assemblies will lie to your left.
4. Place the A1 front frame assembly in the chassis of the instrument.
 - a. Position the A1 front frame assembly in the chassis.
 - b. Insert the three screws (0515-1101) that secure the front frame chassis to the bottom of the spectrum analyzer.
 - c. Insert the three screws (0515-1101) that secure the front frame chassis to the top of the spectrum analyzer.
 - d. Insert the screw (0515-1227) that secures the top of the attenuator to the inside of the A1 front frame assembly.
5. Secure the following connectors to the inside of the A1 front panel assembly.
 - a. INPUT 50 Ω RF connector. Use a 5/16-inch open-end wrench to connect cable W41 to the front panel from the attenuator.
 - b. RF OUT 50 Ω connector *for Option 002 spectrum analyzers*. Use a 5/16-inch open-end wrench to connect cable W47 to the front panel.
 - c. 1ST LO OUTPUT connector. Connect cable W42 from A7J3 to the front panel 1st LO OUTPUT connector.

To replace the 1st LO OUTPUT connector use a 5/16 socket and thread pliers. Use the pliers to hold the 1st LO connector in place,

- while tightening the connector inside the instrument with the 5/16-inch socket.
- d. 1ST LO OUTPUT connector *for Option 002 spectrum analyzers*. Connect W46 from the front panel.
 - e. IF INPUT connector. Connect W36 from the front panel.
6. Replace the following from the face of the front panel:
- a. VOLUME knob and potentiometer. Use a 5/16-inch nut driver to secure the VOLUME potentiometer assembly. Use a 0.050 Allen wrench to replace the two screws (3030-0007) that secure the volume knob to the face of the front panel.
 - b. CAL OUTPUT connector. Replace the dress nut that holds the CAL OUTPUT connector to the front panel.
7. If the line switch has been disconnected from the power supply you will have to route the W3 line switch cable from the right side of the instrument, through the opening behind FL 1, to the power supply on the left side of the instrument.
- a. Loosen the two screws (0515-2332) that secure FL 1 to the instrument's chassis.
 - b. Route the W3 line switch cable from the right side of the instrument to the left side, through the opening that can now be accessed, since FL 1 has been loosened. If the opening is still tight, loosen or remove FL 1 using a 5/16 -inch wrench.
 - c. Secure the W3 line switch cable to the instrument chassis by routing it through the white collar, that is adjacent to the power supply assembly, on the chassis of the instrument.
 - d. Route the W3 line switch cable through the notched opening on the right side of the power supply, and insert the line switch connector into A6J2.

If the line switch has been disconnected from the front panel, see the instructions for its replacement on [page 159](#).

8. Replace the power supply cover by inserting the 3 screws (0515-2309) that secure the power supply cover to the power supply.
9. If the LCD assemblies have not been removed from the front panel assembly, you will need to reconnect the following cables, which are routed through openings in the display driver shield.
 - a. W60, the large ribbon cable (80 lines) that goes to J8 on the A2 controller board.
 - b. W61, a coax cable that connects to J10 on the A2 controller board.
 - c. W64, the VGA ribbon cable (10 lines), that goes to J1 on the rear panel.

Replacement of the Display Driver Board, Inverter Board, and LCD

Follow these steps to replace the A18 LCD assembly, the A17 display driver, and the A17A1 inverter board.

NOTE

If the line switch assembly has been removed from the front panel, it must be replaced before you replace the display driver and LCD assemblies.

1. Place the front panel face down on your bench. The opening for the display will be on the right side of the front panel.
2. If the LCD glass plate has been removed, carefully insert the glass plate into the brackets on the front side of the rubber display mount. Make sure that the side of the glass which has a broad silver border (the left side, when facing the front of the display) is inserted into the side of the mount that has larger brackets, into which the glass plate will slide.

NOTE

The glass plate was originally placed in the LCD assembly in a clean room environment to ensure optimal performance of the LCD display. Take all possible precautions to ensure that the glass plate is clean before placing it in the LCD assembly.

3. Insert the LCD into the display mount. The LCD is correctly oriented when the small ribbon cable from the LCD extends through an opening in the right side of the display mount, and the two backlight cables extend through openings on the left side of the mount.
4. Carefully lower the LCD backplate onto the display mount. Ensure that the ribbon cable on the right, and the two backlight cables on the left, are inserted into the appropriate openings in the LCD backplate.
5. Lower the LCD backplate and LCD assembly, as a unit, into the display section on the right side of the A1 front frame chassis.
6. Secure the LCD backplate to the chassis.
 - a. Insert four (0515-0444) screws into the right side of the backplate. Use a T-8 TORX driver.
 - b. Insert two large (0515-0382) screws into the left side of the LCD backplate. Use a T-15 TORX driver.
7. Place the four black cushions (0400-0333) on the four inner-most posts on the LCD backplate.

8. Place the A17 display driver board on the four black cushions. Insert the four screws (0515-0372) that secure the A17 display driver board to the LCD backplate, into the posts on which you have set the cushions. Use a T-10 TORX driver.
9. If the A17A1 inverter board has been removed from the driver board, proceed to step a. below. If the inverter board is attached to the A17 display driver, proceed to step 10.
 - a. Connect the W62 cable from the A17A1 inverter board to J6 on the A17 display driver board.
 - b. Insert 2 screws (0515-0430) that secure the A17A1 inverter board to the standoffs on the A17 display driver board.
10. Reconnect ribbon cable W63, which connects the A18 LCD with J5 on the A17 display driver board.
11. Connect the two backlight cables from the A18 LCD to the two slotted connectors on the A17A1 inverter board.
12. Route W64, the VGA cable, from J1 on the rear panel, through the rectangular opening in the display driver shield, to J7 on the A17 display driver board (the display driver shield has not yet been secured to the LCD backplate).
13. Lower the display driver shield onto the LCD backplate. Insert four screws (0515-0665) that secure the LCD backplate to the display driver board shield. Use a T-10 TORX driver.
14. Route cable W61 from J9 on the A2 controller board, through the circular opening in the display driver shield, to J7 on the A17 display driver board.
15. Route cable W60 from J8 on the A2 controller board, through the rectangular opening in the display driver shield, to J7 on the A17 display driver board.
16. Connect ribbon cable A1A1W1 from J602 on the A3 interface board to HDR1 on the A1 front panel assembly.

Replacing the Backlights

1. If the LCD or backlights have not been removed from the front frame, follow the procedures outlined in [“Removal of the Front Frame” on page 150](#), [“Removal of the Display Driver Board, Inverter Board, and LCD” on page 152](#), and [“Removal of the Backlights” on page 153](#), as needed.
2. *Carefully* grasp the end of the replacement backlight cartridge (2090-0380), which is attached to the backlight cable, and insert the backlight into the backlight slot at the top of the LCD. Repeat for the backlight located at the bottom of the LCD.

NOTE

Whenever there is a need to replace a single backlight, both backlights must be replaced.

3. Insert the LCD into the display mount. The LCD assembly is correctly oriented when the small ribbon cable extends through an opening in the right side of the display mount.
4. Follow steps 4 through 17 of [“Replacement of the Display Driver Board, Inverter Board, and LCD”](#) on page 157 to complete replacement of the LCD into the front panel. Follow the instructions in [“Replacement of the Front Frame”](#) on page 155 to replace the front panel in the front frame.

Replacement of the Line Switch

After you have replaced the A1 front frame assembly you can replace the line switch by following these steps (note that the line switch must be replaced before the LCD and display driver can be replaced):

1. Insert the line switch into the A1 front frame assembly. Insert the two screws (0515-1521) that secure the line switch to the front frame.
2. Insert the screw (0515-0430) that secures the striped green and white ground cable for the line switch (this screw also secures the ground for the power probe; if the black cable from the power probe cable assembly is not secured to the ground, secure it also).
3. Carefully insert the green LED from the top-center of the line switch assembly into the LED opening in the A1 front frame assembly.

Replacement of the Keyboard

1. Insert the seven screws (0515-1934) that secure the front frame PC board to the A1 front frame assembly. Use a T-8 TORX driver.
2. Connect the RPG cable to the RPG connector on the front frame PC board.
3. Connect the power probe cable to the connector that is labelled “probe power” on the front frame PC board.
4. Connect A1A1W1 from HDR1 on A1 front frame assembly to A3J602 on the A3 interface board.

Procedure 2B. A1 Front Frame/A18 CRT (8560E)

Removal

WARNING

The voltage potential at A6A1W3 is +9 kV. Disconnect at the CRT with caution! Failure to properly discharge A6A1W3 may result in *severe electrical shock* to personnel and damage to the instrument.

1. Remove the spectrum analyzer cover assembly as described in "Procedure 1. Spectrum Analyzer Cover."
2. Fold out the A2, A3, A4, and A5 assemblies as described in steps 2 through 6 under "Procedure 5. A2, A3, A4, and A5 Assemblies Removal."
3. Disconnect A1A1W1 from A3J602.
4. Place the spectrum analyzer top-side-up on the workbench.
5. Connect the spectrum analyzer line-power cord to provide proper grounding while discharging the A6A1W3 post-accelerator cable. Make sure that the spectrum analyzer line-power switch is in the off position.
6. Connect a high voltage probe (1000:1), such as the HP 34111A to a voltmeter with a 10 megohm input.
7. Connect the clip lead of the probe (ground) to the chassis of the spectrum analyzer.
8. Slip the tip of the high voltage probe under the rubber shroud of the A6A1W3 post-accelerator cable to obtain a reading on the voltmeter. See [Figure 3-3 on page 162](#).
9. Keep the high voltage probe on the post-accelerator connector until the voltage has dropped to a voltmeter reading of less than 5 mV (less than 5 V at the connector). This normally takes about 30 seconds.
10. Disconnect the line-power cord from the spectrum analyzer.

WARNING

To avoid possible electrical shock, in the next step, use a screwdriver having a conductive metal shank and tip, with an insulated handle.

11. Connect one end of a wire clip lead to a small screwdriver having a conductive shank and tip. Connect the other end of the clip lead to the CRT shield assembly as shown in [Figure 3-3 on page 162](#). Hold the insulated screwdriver handle and slip the tip of the screwdriver under the rubber shroud of the A6A1W3 post-accelerator cable, shorting the cable to ground through the CRT shield assembly. See [Figure 3-3 on page 162](#).
12. Using a small screwdriver with the shank in contact with the CRT shield assembly, slip the tip of the screwdriver under the A6A1W3 post-accelerator cable rubber shroud and short the cable to ground on the CRT shield assembly.
13. Pry out the black grommet protecting post-accelerator cable A6A1W3 from the CRT shield assembly.
14. Carefully unsnap the A6A1W3 post-accelerator cable from the CRT and discharge it by shorting the cable to chassis ground on the CRT shield assembly.
15. Place the spectrum analyzer on its right side frame with the front frame assembly hanging over the front edge of the workbench.
16. Fold out the A14 and A15 assemblies as described in steps 3 and 4 under "Procedure 9. A14 and A15 Assemblies Removal."

WARNING

The voltage potential at A6A1W3 is +9 kV. Failure to discharge A6A1W3 correctly may result in *severe electrical shock* to personnel and damage to the instrument.

Figure 3-3 Discharging High Voltage on the CRT

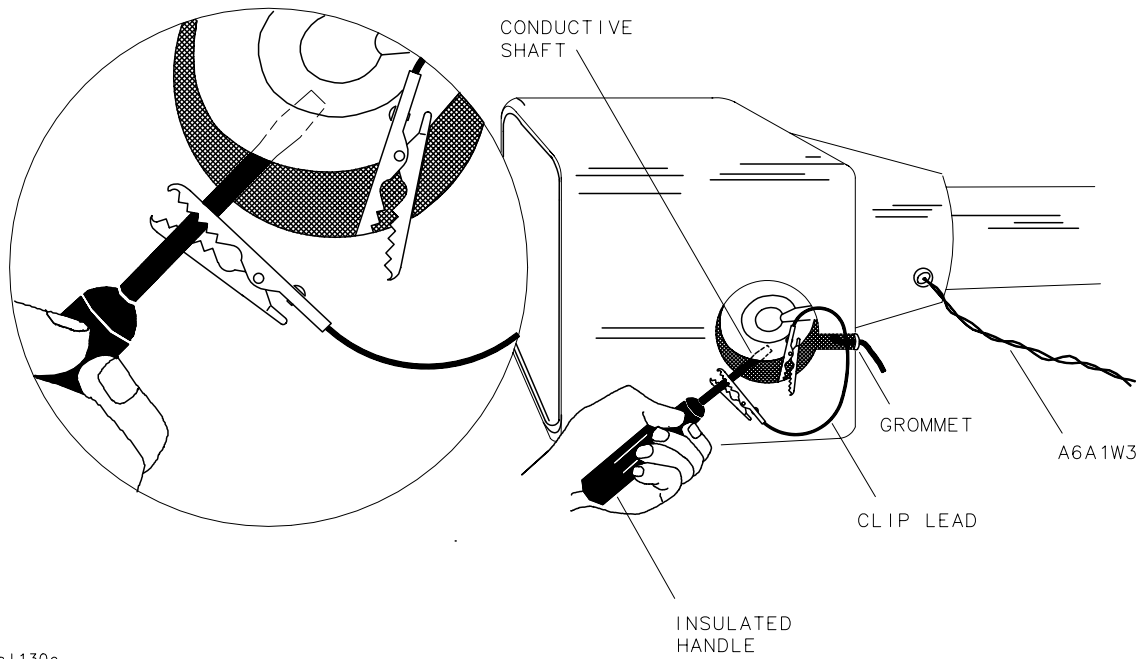
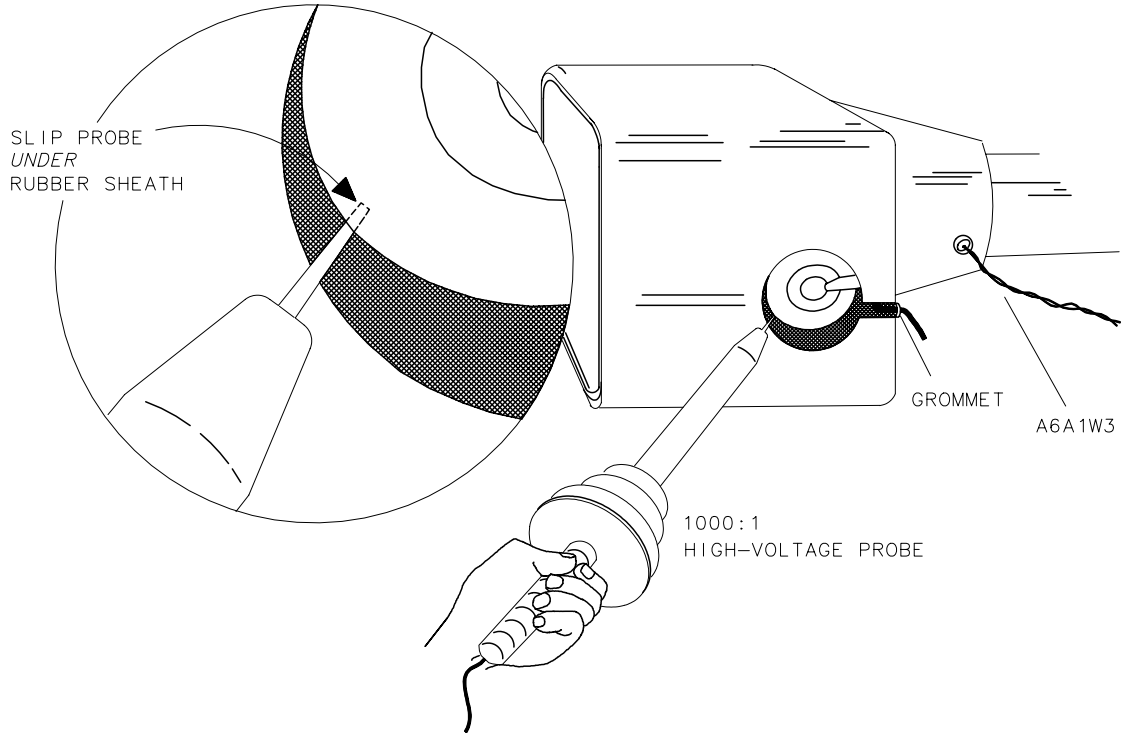

.s1130e

Figure 3-4 A9, A18, and Line Switch Assembly Mounting Screws

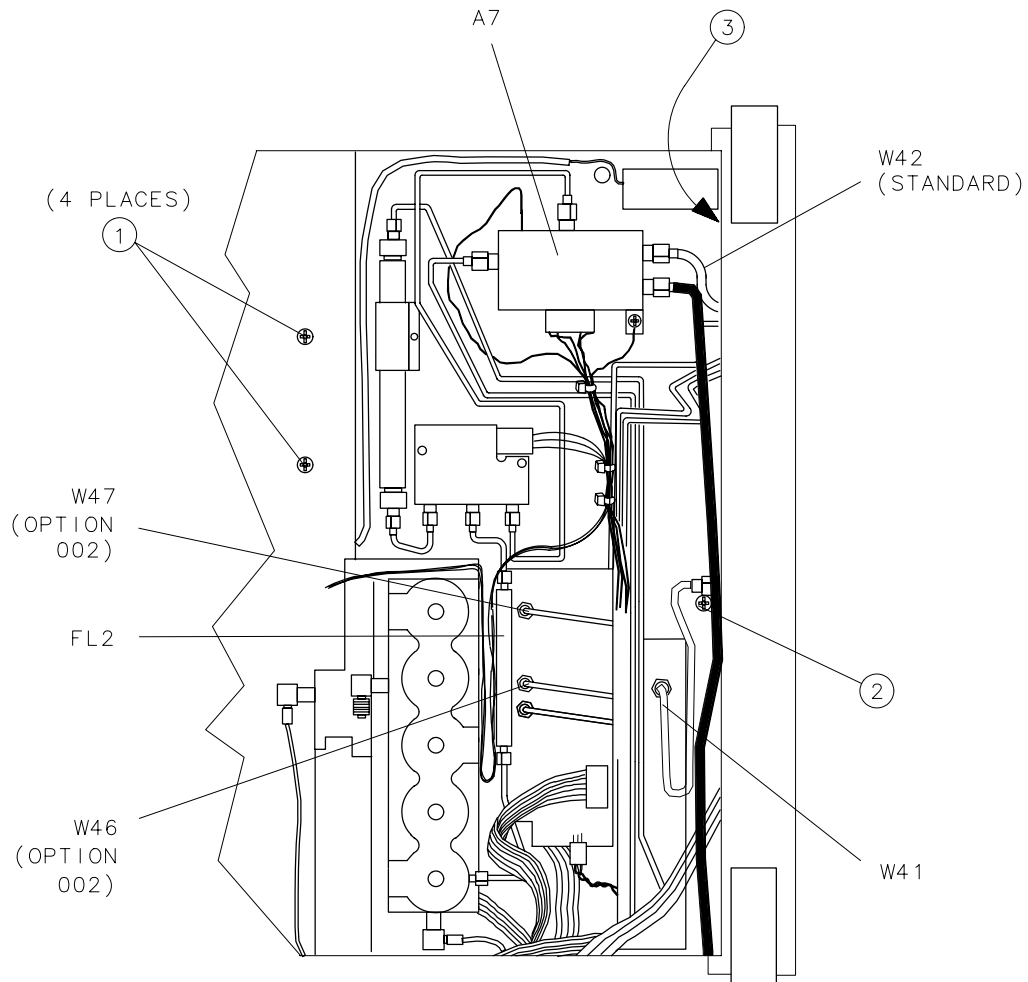

17. Remove screw (2) securing the A9 input attenuator assembly to the center support on the front frame. See [Figure 3-4 on page 163](#).
18. Use a 5/16-inch open-end wrench to disconnect W41 from the front panel INPUT 50 Ω connector. Loosen the opposite end of W41.
19. *For Option 002 spectrum analyzers:* use a 5/16-inch open-end wrench to disconnect W47 from the front panel RF OUT 50 Ω connector.
20. Disconnect W42 from A7J3 and the front panel 1ST LO OUTPUT connector. *For Option 002 spectrum analyzers:* disconnect W46 from the front panel 1ST LO OUTPUT connector.
21. Disconnect W36, coax 86, from the front panel IF INPUT connector.

22. Remove the VOLUME knob and potentiometer from the front panel. If necessary, drill out the nut driver used to remove the VOLUME potentiometer and cover the tip with heatshrink tubing or tape to avoid scratching the enameled front panel.
23. Use a 9/16-inch nut driver to remove the dress nut holding the front panel CAL OUTPUT connector to the front panel. If necessary, drill out the nut driver to fit over the BNC connectors and cover the tip with heatshrink tubing or tape to avoid scratching the enameled front panel.
24. Remove screw (3) securing the line switch assembly to the front frame. See [Figure 3-4 on page 163](#).
25. Gently remove the line switch assembly, using caution to avoid damaging A1W1 and power indicator LED A1W1DS1.
26. Remove A1W1 and A1W1DS1 from the line-power switch assembly.
27. Remove the three screws (1) securing the front frame assembly to the spectrum analyzer right side frame. See [Figure 3-5 on page 164](#).

Figure 3-5 Front Frame Mounting Screws

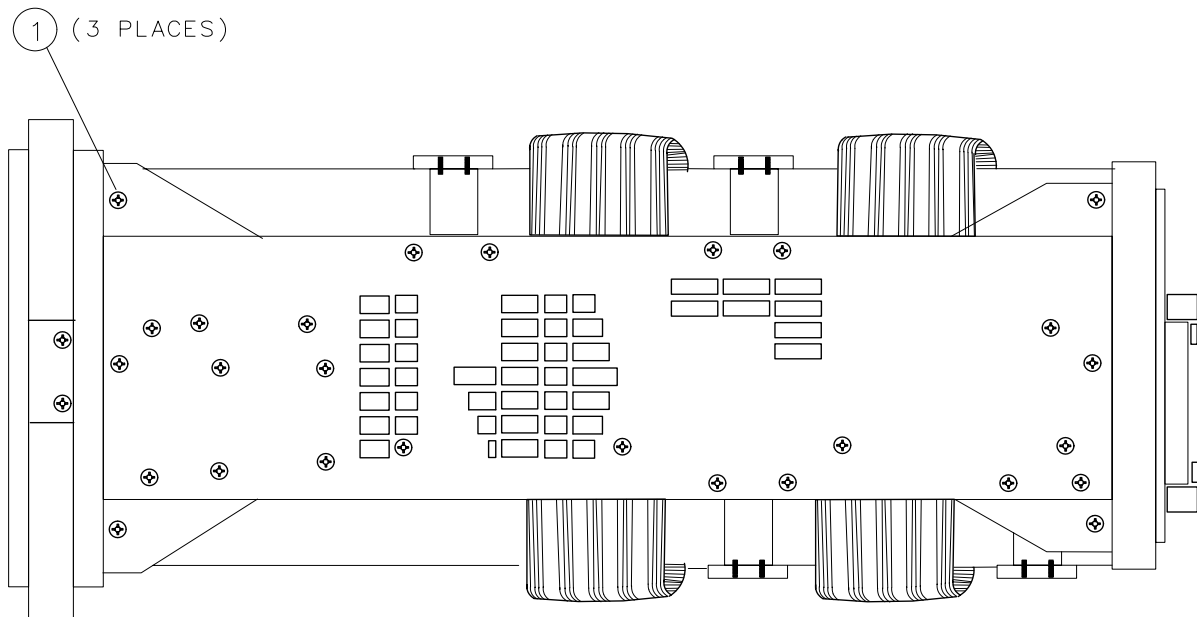

s1116e

28. Remove the three screws securing the front frame assembly to the spectrum analyzer left side frame.
29. Remove the four screws (1) ([Figure 3-4 on page 163](#)) securing the CRT clamps to the deck.

30. Pull the cable tie (1) to free W9. See [Figure 3-6 on page 165](#). Gently pry W9, the CRT cable, from the end of the CRT assembly.
31. Support the A18 CRT assembly while gently pulling the front frame and CRT out of the spectrum analyzer 1 or 2 inches.
32. Disconnect A18W1, the trace align wires, from A17J5. Remove the front frame and CRT assemblies.
33. Gently pull the CRT assembly off of the front frame assembly.

Figure 3-6 **Installing the CRT and front Frame Assemblies**

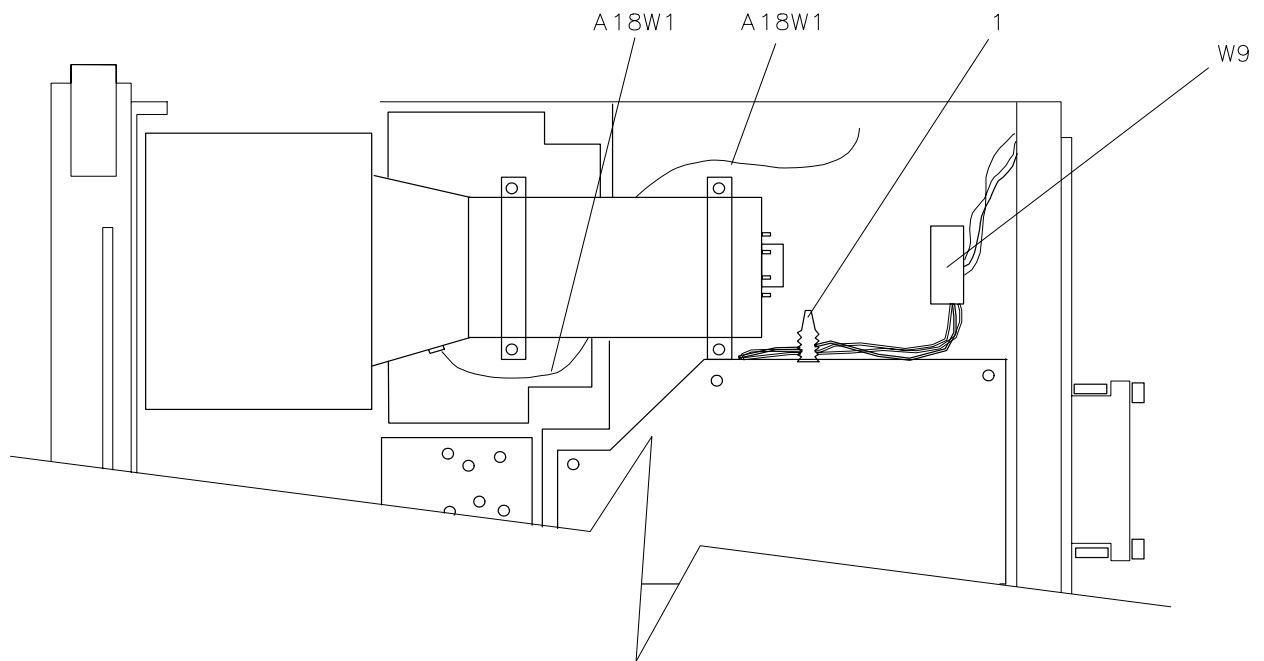

SK126

Replacement

NOTE

Use care when handling the glass CRT EMI shield. The glass may be cleaned using thin film cleaner (HP part number 8500-2163) and a lint-free cloth. When installing the glass shield, face the side of the glass with the silver coated edge towards the inside of the spectrum analyzer.

1. Place the spectrum analyzer on its right side frame with the front end extending slightly over the front of the workbench.

2. Gently place the A18 CRT assembly into the A1 front frame assembly as illustrated in [Figure 3-7 on page 166](#).
3. Place the front frame and CRT assemblies into the spectrum analyzer, using caution to avoid pinching any cables.
4. Dress the A18W1 trace-align wires between the CRT assembly mounts and the A6 power supply top shield.

Figure 3-7 **Placing the CRT into the Front Frame**

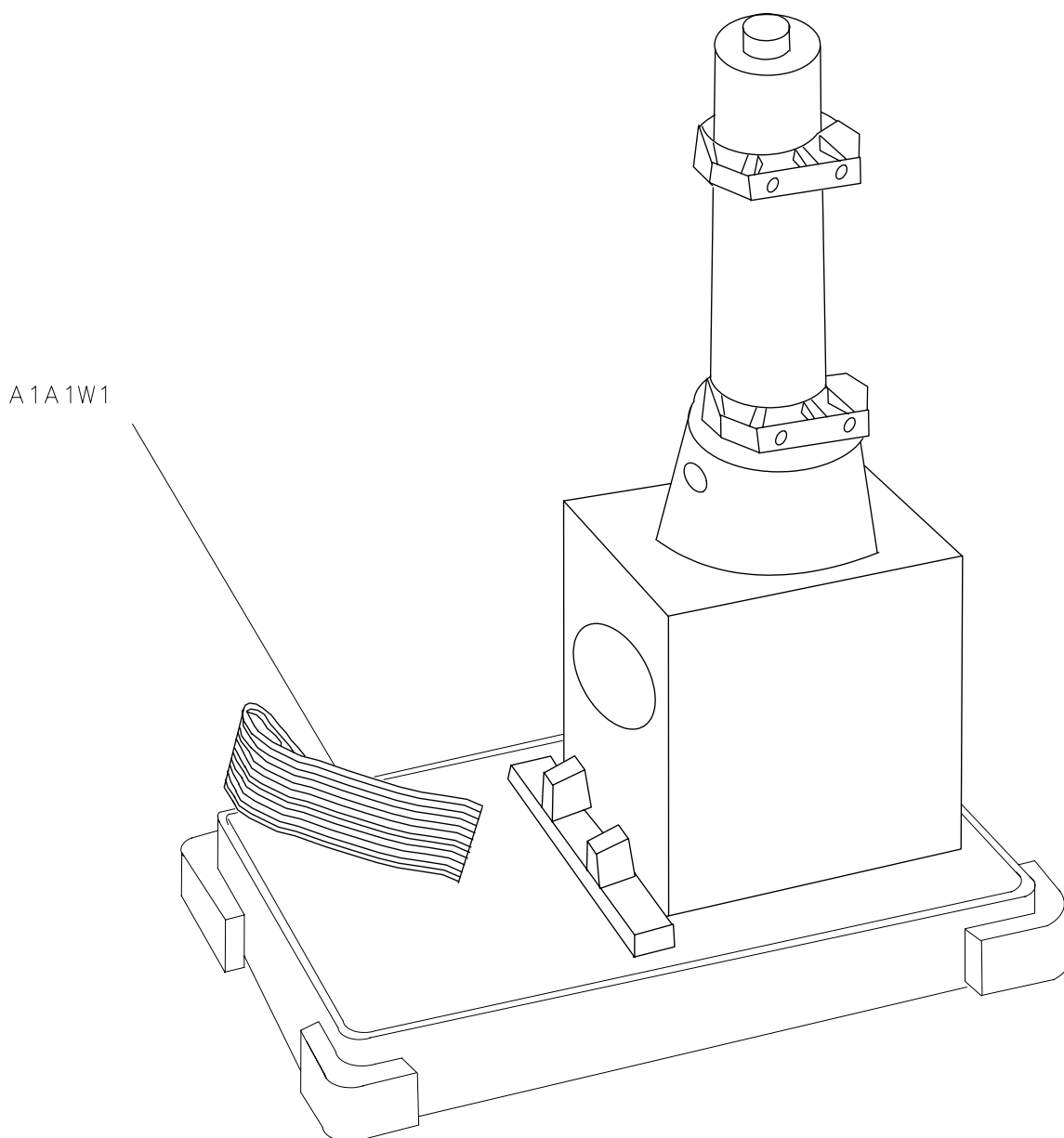

SK12

5. Connect A18W1 to A17J5.
6. Snap CRT cable W9 onto the end of the CRT assembly.
7. Fully seat the front frame and CRT assemblies into the spectrum analyzer.
8. Secure the front frame to the spectrum analyzer side frames, using three flathead screws per side. See [Figure 3-5 on page 164](#).
9. Retighten the four screws securing the CRT clamps to the deck.
10. Place W9 between the CRT assembly and the A6 power supply assembly top shield so that the W9 wires are underneath the surface of the top shield.
11. Connect W42 to A7J3 and the front panel 1ST LO OUTPUT connector. *For Option 002 spectrum analyzers:* connect W46 to the front panel 1ST LO OUTPUT connector.
12. Use a 9/16-inch nut driver to reconnect CAL OUTPUT connector to the front panel.
13. Connect the VOLUME potentiometer and knob to the front panel.
14. *For Option 002 spectrum analyzers:* use a 5/16-inch open-end wrench to connect W47 to the front panel RF OUT connector.
15. Connect W36, coax 86, to the front panel IF INPUT connector.
16. Use a 5/16-inch wrench to connect W41 from the A9 input attenuator to the front panel INPUT 50 Ω connector. Make sure that W40, W36, and A1W1 are routed between W41 and the attenuator bracket. Secure the A9 input attenuator bracket to the center support on the front frame using one panhead screw. See [Figure 3-4 on page 163 \(2\)](#).
17. Place led A1W1DS1 into the line-power switch assembly.
18. Attach the line switch assembly into the front frame using one panhead screw. Be sure to connect the line-power switch ground lug with the screw. The screw is captive.
19. Fold up the A14 and A15 assemblies as described in steps 3 through 5 under "Procedure 9. A14 and A15 Assemblies Replacement."
20. Place the spectrum analyzer top-side-up on the workbench and connect A1A1W1 to A3J602.
21. Snap post-accelerator cable A6A1W3 to the A18 CRT assembly.
22. Snap the black grommet protecting the A6A1W3 into the CRT shield.
23. Fold up assemblies A2, A3, A4, and A5 as described in steps 6 through 12 under "Procedure 5. A2, A3, A4, and A5 Assemblies Replacement."

24. Replace the spectrum analyzer cover assembly.

25. Connect the line-power cord and switch the spectrum analyzer power on. If the display does not operate properly, turn off spectrum analyzer power, disconnect the line cord, and recheck the spectrum analyzer.

Procedure 3. A1A1 Keyboard/Front Panel Keys

Removal

1. Remove the front frame from the spectrum analyzer. Place the front frame face down on the bench. For 8560EC instruments, follow the instructions in "Procedure 2A. A1 Front Frame/A22 LCD (8560EC)." For 8560E instruments, follow the instructions in "Procedure 2B. A1 Front Frame/A18 CRT (8560E)."

For 8560EC instruments, proceed to step 3. For 8560E instruments, proceed to step 2.

2. Remove the front frame center support.
3. Disconnect A1W1 from A1A1J3 and the RPG cable from A1A1J2.
4. Remove the nine screws holding the A1A1 keyboard assembly to the front frame and remove the assembly.
5. Remove the rubber keypad.

NOTE

In 8560E instruments, the front panel softkey actuators are part of the CRT bezel assembly and are not replaceable. Should the softkeys become damaged, replace the bezel assembly.

Replacement

1. Install the rubber keypad, ensuring that the screw holes are visible through the pad.
2. Place the A1A1 keyboard assembly over the rubber keypad. Secure with nine panhead screws.
3. Connect the RPG cable to A1A1J2, and A1W1 to A1A1J3.

For 8560EC instruments, proceed to step 5. For 8560E instruments, proceed to step 4.

4. Secure the center support to the front frame using two panhead screws. The arrow stamped on the center support should point to the top of the frame.
5. Install the front frame assembly. For 8560EC instruments, follow the instructions in "Procedure 2A. A1 Front Frame/A22 LCD (8560EC)." For 8560E instruments, follow the instructions in "Procedure 2B. A1 Front Frame/A18 CRT (8560E)."

Procedure 4. A1A2 RPG

Removal

1. Remove the A9 input attenuator as described in "Procedure 8. A7 through A13 Assemblies."
2. Disconnect the RPG cable from the A1A1 keyboard assembly.
3. If the serial number of your instrument is above or equal to 3738A03198 (8560E/EC) proceed to step a. If the serial number of your instrument is below 3738A03198 (8560E) proceed to step b.
 - a. Pull the front panel RPG knob off of the face of the front panel of the spectrum analyzer. Proceed to step 4.
 - b. Remove the set screw from the front panel RPG knob using a number 6 hex (Allen) wrench. Proceed to step 4.
4. Use a 7/16-inch nut driver, set to 20-in./lbs., to remove the nut holding the RPG shaft to the front panel.
5. Remove the RPG.

Replacement

1. Place the RPG into the front frame with the cable facing the bottom of the spectrum analyzer. Place a lock washer and nut on the RPG shaft to hold it in the frame. If the serial number of your instrument is below 3738A03198 (8560E) proceed to step a. Otherwise, proceed to step 2.
 - a. Insert the set screw into the RPG knob using a number 6 hex (Allen) wrench. Proceed to step 2.
2. Use a 7/16-inch nut driver to secure the RPG assembly to the front frame.
3. Connect the RPG cable to A1A1J2.
4. Insert the RPG knob into the front panel assembly.
5. Replace the A9 input attenuator as described in "Procedure 8. A7 through A13 Assemblies."

Procedure 5. A2, A3, A4, and A5 Assemblies

Removal

1. Remove the spectrum analyzer cover.
2. Place the spectrum analyzer on its right side frame.
3. Remove the eight screws holding the A2, A3, A4, and A5 assemblies to the top of the spectrum analyzer. These screws are labeled (2), (3), and (4) in [Figure 3-8 on page 172](#). They are also labeled on the back of the A2 board assembly.
4. Remove ribbon cable W4 from A2J6. See [Figure 3-8 on page 172](#).

CAUTION

Do not fold the board assemblies out of the spectrum analyzer one at a time. Always fold the A2 and A3 assemblies as a unit and the A4 and A5 assemblies as a unit. Folding out one assembly at a time binds the hinges attaching the assemblies and may damage an assembly and hinge.

5. The board assemblies are attached to the right side frame of the spectrum analyzer with two hinges. Fold both the A2 and A3 assemblies out of the spectrum analyzer as a unit.
6. Fold both the A4 and A5 assemblies out of the spectrum analyzer as a unit.
7. Remove the cables from the assembly being removed, as illustrated in [Figure 3-9 on page 173](#).
8. Remove the two screws that attach the assembly being removed to its two mounting hinges.

CAUTION

Do not torque shield TORX screws to more than 8 inch-pounds. Applying excessive torque will cause the screws to stretch.

NOTE

Diagrams that illustrate features common to E-series and EC-series instruments are shown with E-series instruments. Where there are differences between E-series and EC-series features separate diagrams are provided.

Figure 3-8 **A2, A3, A4, and A5 Assembly Removal**

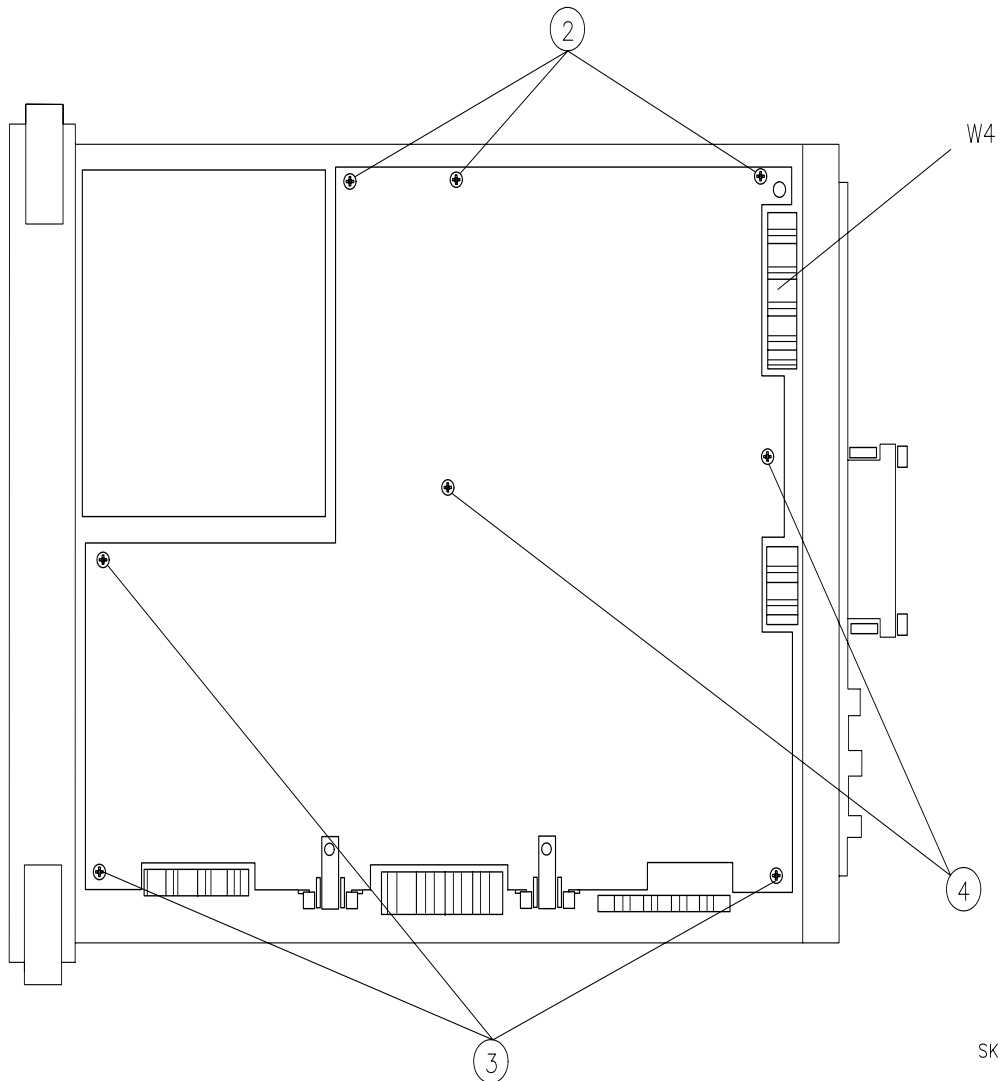

SK129

Replacement

1. Place the spectrum analyzer on its right side on the work bench.
2. Attach the assembly being installed to the two chassis hinges with two panhead screws.
3. Leave the assembly in the folded-out position and attach ribbon cables W1 and W2.
4. Attach all cables to the assembly, as illustrated in [Figure 3-9 on page 173](#).
5. Locate the cable clip on the inside of the right side frame. Make sure

that the coaxial cables are routed properly on the clip as illustrated in [Figure 3-12 on page 175](#) for EC-series instruments, and in [Figure 3-13 on page 176](#) for E-series instruments.

6. Lay the A2, A3, A4, and A5 assemblies flat against each other in the folded-out position. Make sure that no cables become pinched between the two assemblies.

Figure 3-9 Assembly Cables (1 of 3) – EC-Series

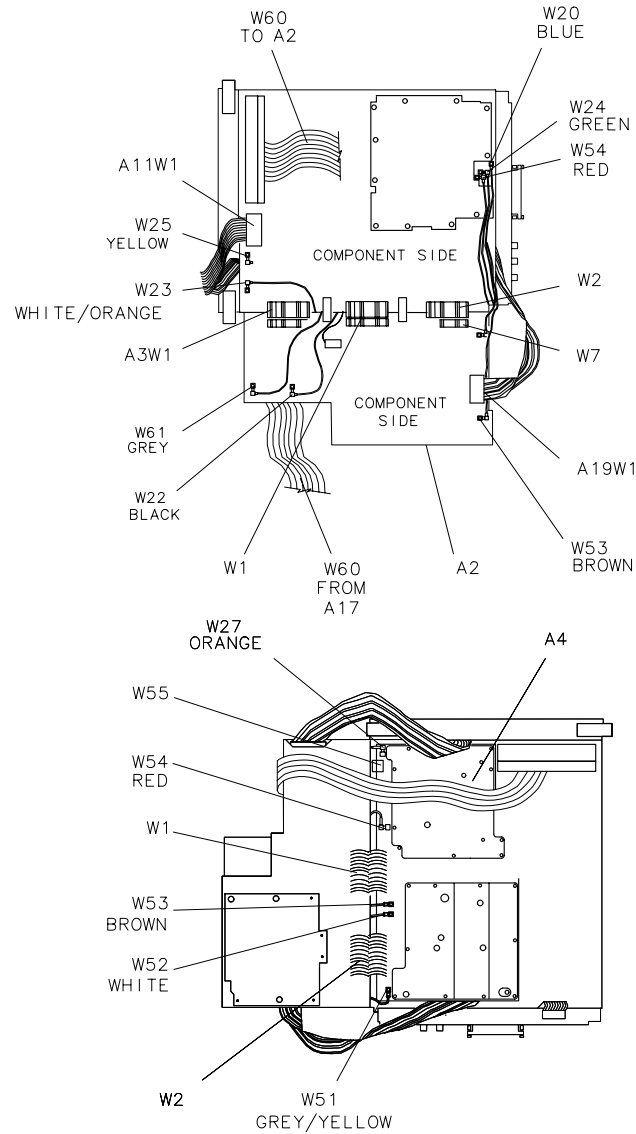

sp119c

Figure 3-10 Assembly Cables (2 of 3) – EC-series

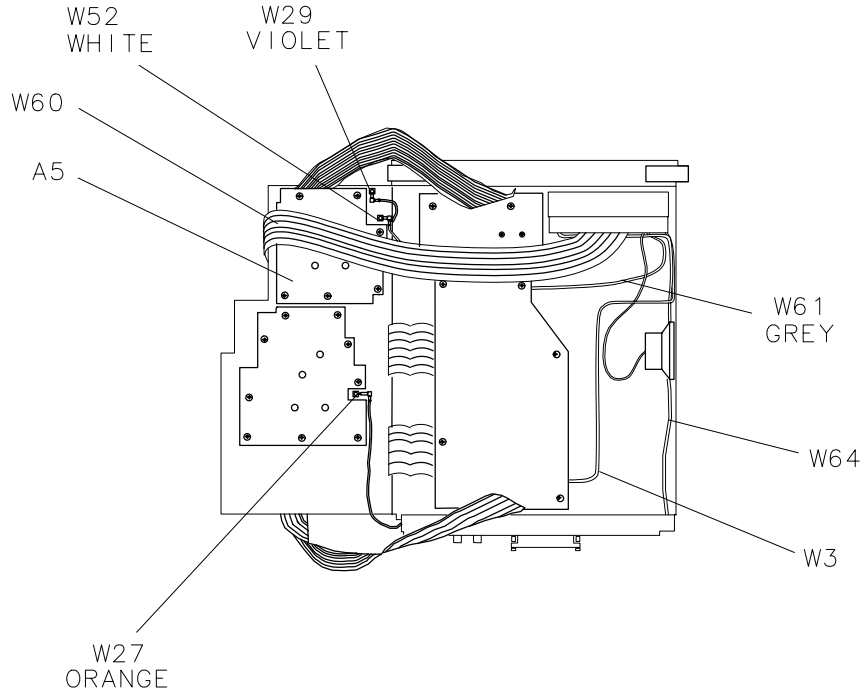

s l 113c

Figure 3-11 Assembly Cables (3 of 3)– E-series

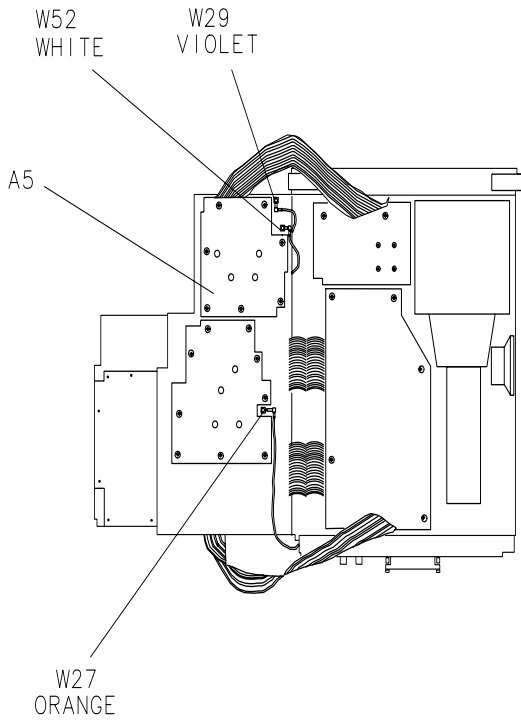

s l 18e

Figure 3-12 Coaxial Cable Clip – EC-Series

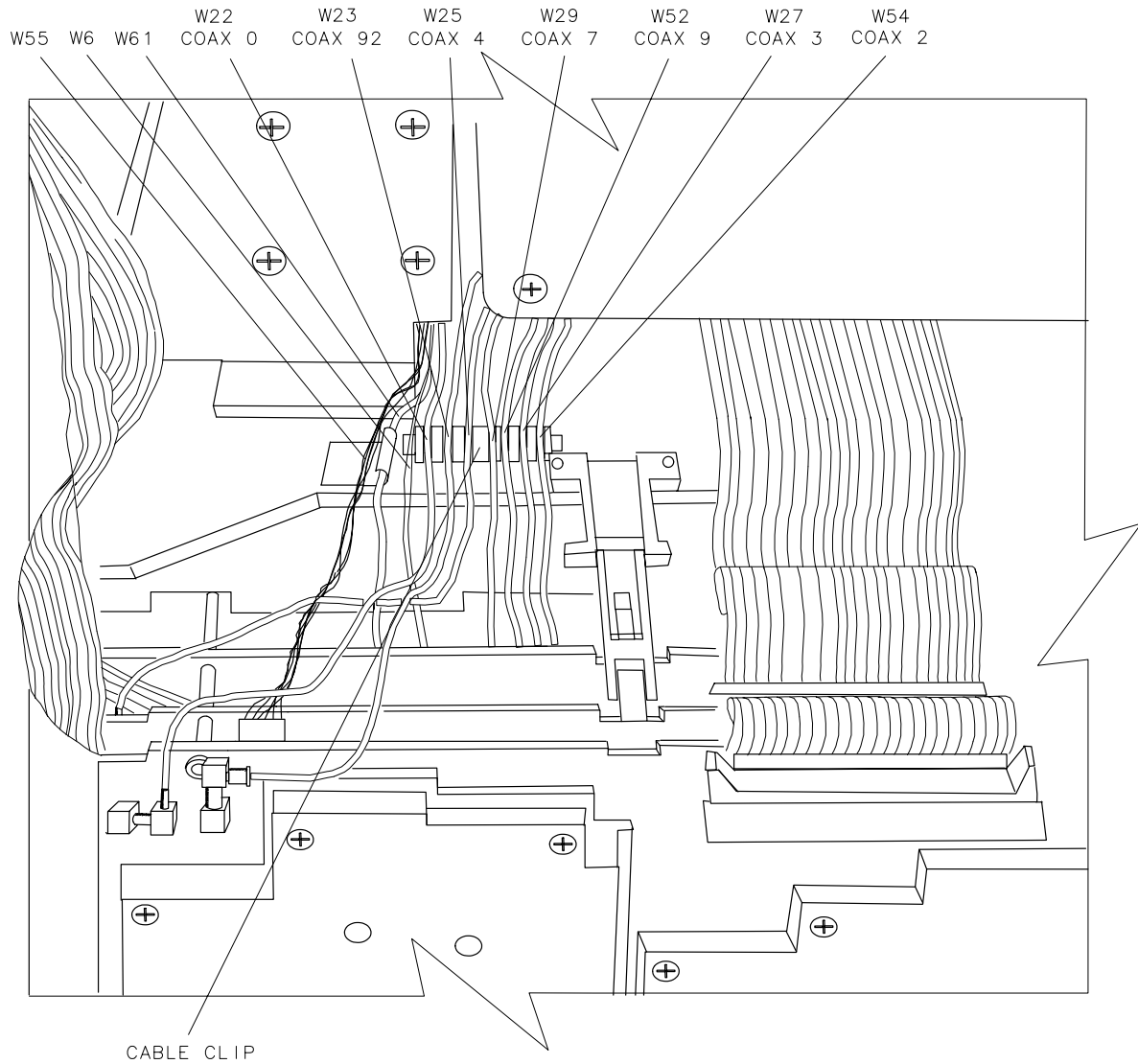

s1121c

7. Check to ensure that no cables will become pinched under the hinges when folding up the A4 and A5 assemblies.

8. Fold the A4 and A5 assemblies together as a unit into the spectrum analyzer. Use caution to avoid damaging any cable assemblies. The standoffs on the A5 assembly must fit into the cups on the A6 power supply top shield.
9. Fold the A2 and A3 assemblies together as a unit into the spectrum analyzer. Be sure to fold HP-IB cable A19W1 between the A3 and A4 assemblies, using the two sets of hook and loop (Velcro) fasteners.
10. Fold ribbon cable A1A1W1 between A3 and A4 assemblies. Take care to dress the protective tubing as close to A3J602 connector as possible, so that the tubing does not fold with the cable. See [Figure 3-14 on page 177](#).
11. Attach ribbon cable W4 to A2J6 while folding up the assemblies.
12. Secure the assemblies using the eight screws removed in "Removal," step 3. See [Figure 3-8 on page 172](#).

Figure 3-13 Coaxial Cable Clip – E-Series

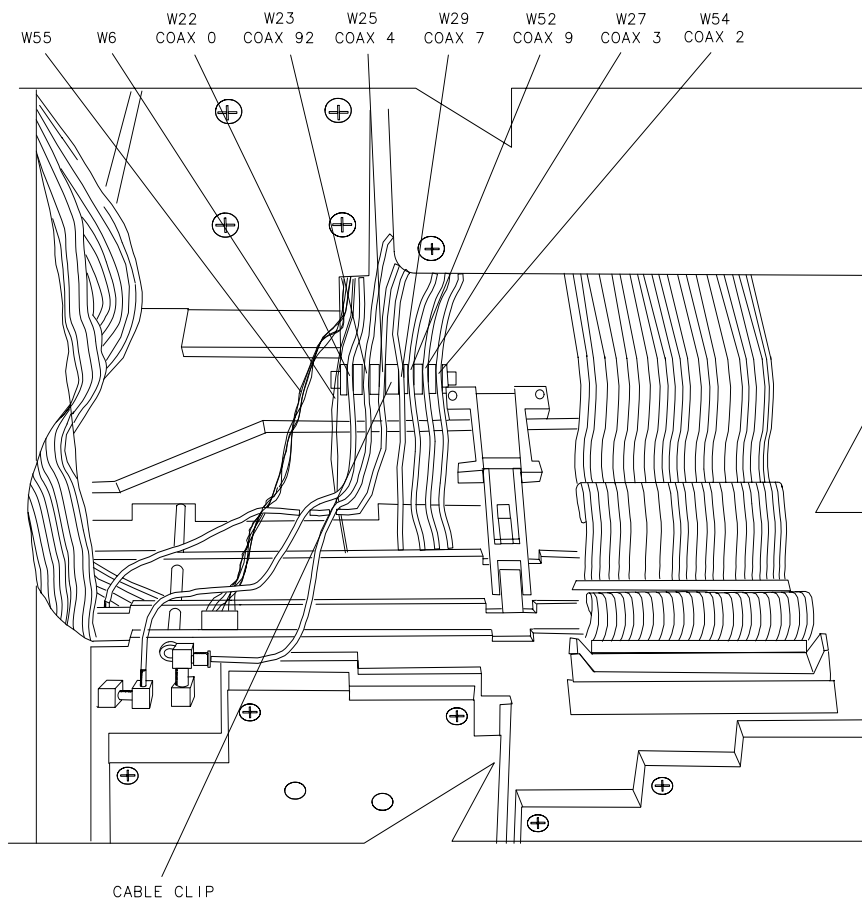

s119e

Figure 3-14 HP-IB and A1A1 W1 Cable Placement

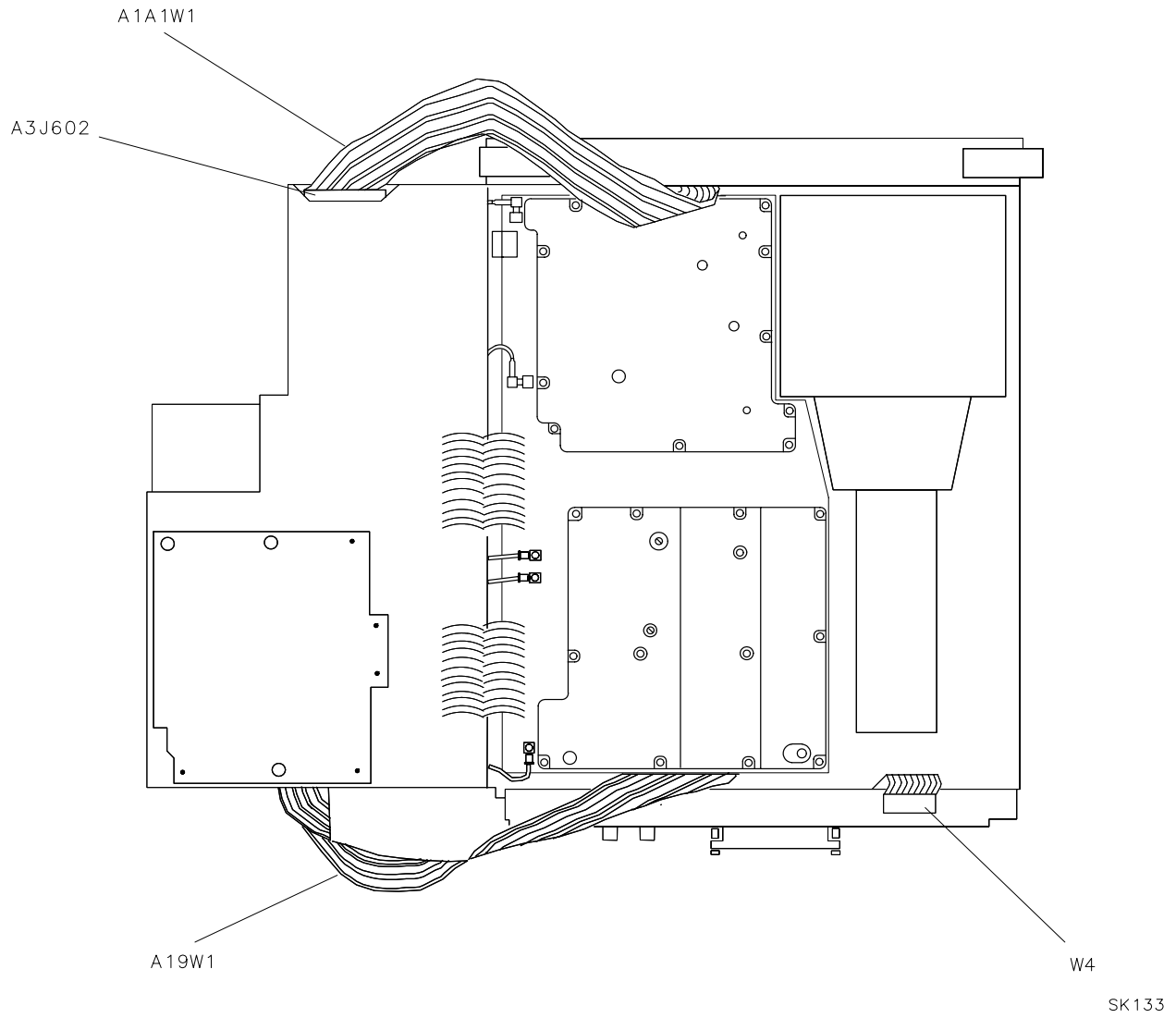

Procedure 6A. A6 Power Supply Assembly (8560EC)

Removal

WARNING

The A6 Power Supply assembly contains lethal voltages with lethal currents in all areas. Use extreme care when servicing this assembly. Always disconnect the power cord from the instrument before beginning this replacement procedure. Failure to follow this precaution will represent a shock hazard which may result in personal injury.

1. Disconnect the power cord from the spectrum analyzer.
2. Remove the spectrum analyzer cover assembly. Refer to "Procedure 1. Spectrum Analyzer Cover."
3. Fold out the A2, A3, A4, and A5 assemblies as described in steps 2 through 6 under "Procedure 5. A2, A3, A4, and A5 Assemblies Removal."
4. Place the spectrum analyzer on the workbench with A2, A3, A4, and A5 folded out to the right.
5. Remove the three screws securing the power supply shield to the power supply and remove the shield. See [Figure 3-16 on page 180](#).
6. Disconnect all cables from the A6 power supply assembly. See [Figure 3-17 on page 183](#).
7. Use a T-10 TORX driver to remove the screws from the shield wall, the heatsink, the base of the power supply (0515-1950) and the A6 power supply assembly.
8. Remove the A6 power supply assembly by lifting from the regulator heatsink toward the front of the spectrum analyzer.

Figure 3-15 **Power Supply Cover**

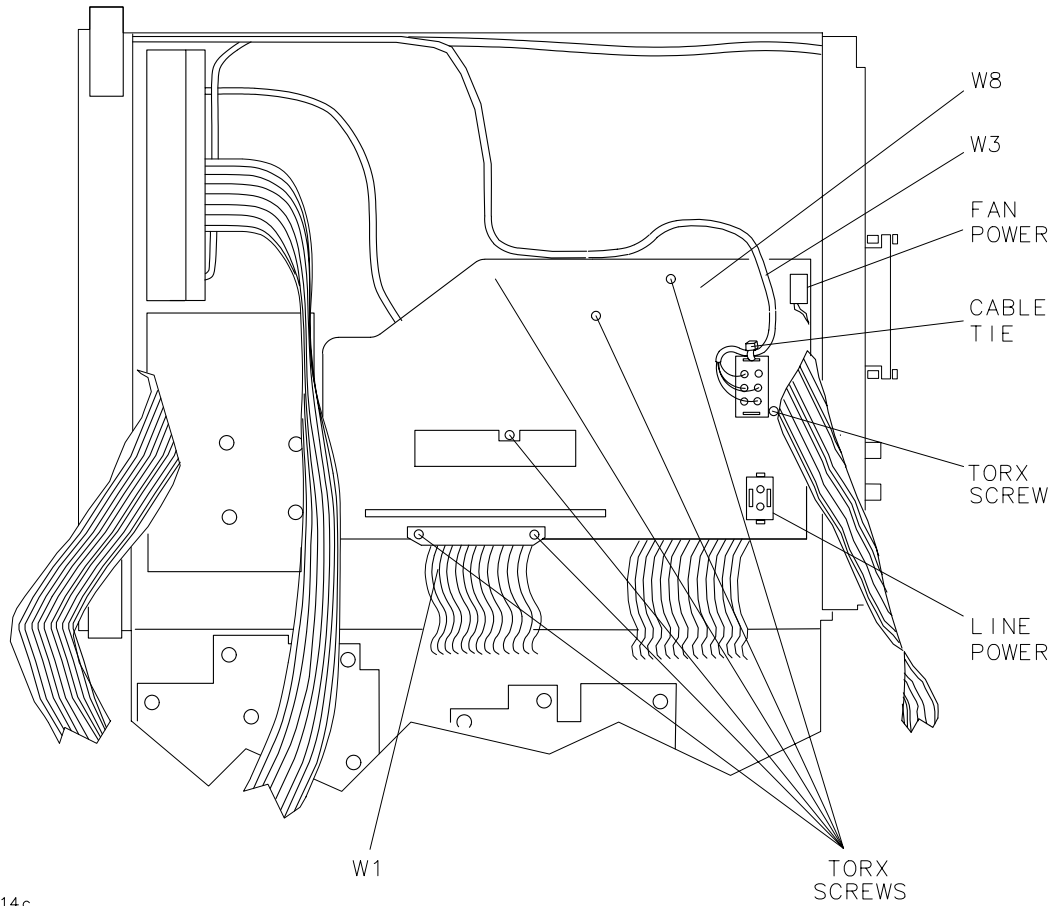

s1114c

Replacement

1. Ensure that the bottom shield wall is in place before replacing the A6 power supply assembly.
2. Attach the A6 power supply assembly to the spectrum analyzer chassis and top shield wall using the four screws, torqued to 10-inch lbs. Attach all other screws, torqued to 6-inch lbs.
3. Connect W1 to A6J1, W3 to A6J2, fan power wires to A6J3, W8 to A6J4, and the line-power jack to A6J101. See [Figure 3-17 on page 183](#).
4. Ensure that all cables are safely routed and will not be damaged when securing the A6 cover.
5. Secure the power supply cover shield to the power supply using three flathead screws (1). See [Figure 3-16 on page 180](#). One end of the cover fits into a slot provided in the rear frame assembly. Ensure that the extended portion of the cover shield is seated in the shield wall groove.
6. Fold the A2, A3, A4, and A5 assemblies into the spectrum analyzer as described in steps 6 through 12 under "Procedure 5. A2, A3, A4, and A5 Assemblies Replacement."

Figure 3-16 Power Supply Cover

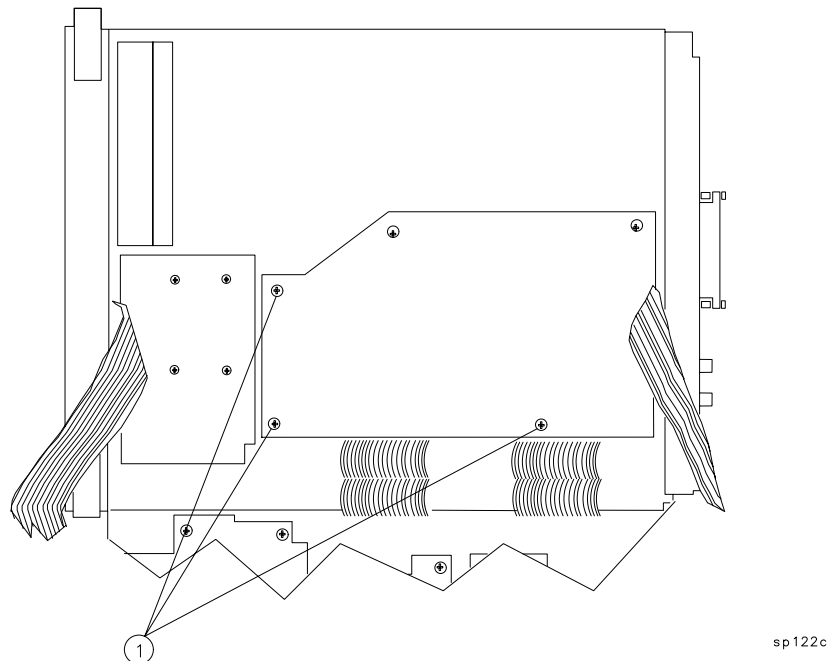

Procedure 6B. A6 Power Supply Assembly (8560E)

Removal

WARNING

The A6 Power Supply and A6A1 High Voltage assemblies contain lethal voltages with lethal currents in all areas. Use extreme care when servicing these assemblies. Always disconnect the power cord from the instrument before beginning this replacement procedure. Failure to follow this precaution will represent a shock hazard which may result in personal injury.

1. Disconnect the power cord from the spectrum analyzer.
2. Remove the spectrum analyzer cover assembly. Refer to "Procedure 1. Spectrum Analyzer Cover."
3. Fold out the A2, A3, A4, and A5 assemblies as described in steps 2 through 6 under "Procedure 5. A2, A3, A4, and A5 Assemblies Removal."
4. Place the spectrum analyzer top-side-up on the workbench with A2, A3, A4, and A5 folded out to the right.

WARNING

The voltage potential at A6A1W3 is +9 kV. Disconnect at the CRT with caution! Failure to properly discharge A6A1W3 may result in *severe electrical shock* to personnel and damage to the instrument.

5. Connect the spectrum analyzer line-power cord to provide proper grounding while discharging the A6A1W3 post-accelerator cable. Make sure that the spectrum analyzer line-power switch is in the off position.
6. Connect a high voltage probe (1000:1), such as the HP 34111A to a voltmeter with a 10 megohm input.
7. Connect the clip lead of the probe (ground) to the chassis of the spectrum analyzer.
8. Slip the tip of the high voltage probe under the A6A1W3 post-accelerator cable rubber shroud to obtain a reading on the voltmeter. See [Figure 3-3 on page 162](#).
9. Keep the high voltage probe on the post-accelerator connector until the voltage has dropped to a voltmeter reading of less than 5 mV (less than 5 V at the connector). This normally takes about 30 seconds.

10. Disconnect the line-power cord from the spectrum analyzer.
11. Using a small screwdriver with the shank in contact with the CRT shield assembly, slip the tip of the screwdriver under the A6A1W3 post-accelerator cable rubber shroud and short the cable to ground on the CRT shield assembly. See [Figure 3-3 on page 162](#).
12. Remove the three screws securing the power supply shield to the power supply and remove the shield.
13. Remove the three screws securing the A6A1 high voltage assembly to the A6 power supply assembly.
14. Disconnect ribbon cable A6A1W1 from A6J5 and lift the A6A1 assembly out of the way. See [Figure 3-17 on page 183](#).
15. Disconnect all cables from the A6 power supply assembly. See [Figure 3-17 on page 183](#).
16. Use a TORX screwdriver to remove the hardware from the shield wall, the heatsink, and the A6 power supply assembly.
17. Remove the A6 power supply assembly by lifting from the regulator heatsink toward front of spectrum analyzer.

Replacement

1. Ensure that the bottom shield wall is in place before replacing the A6 power supply assembly.
2. Attach the A6 power supply assembly to the spectrum analyzer chassis and top shield wall using the four screws.
3. Connect W1 to A6J1, W3 to A6J2, fan power wires to A6J3, W8 to A6J4, and the line-power jack to A6J101. See [Figure 3-17 on page 183](#).
4. Secure the A6A1 high voltage assembly to the A6 power supply assembly, using three panhead screws. Connect ribbon cable A6A1W1 to A6J5.
5. Snap post-accelerator cable A6A1W3 to the CRT assembly.

Figure 3-17 A6 Power Supply Connections

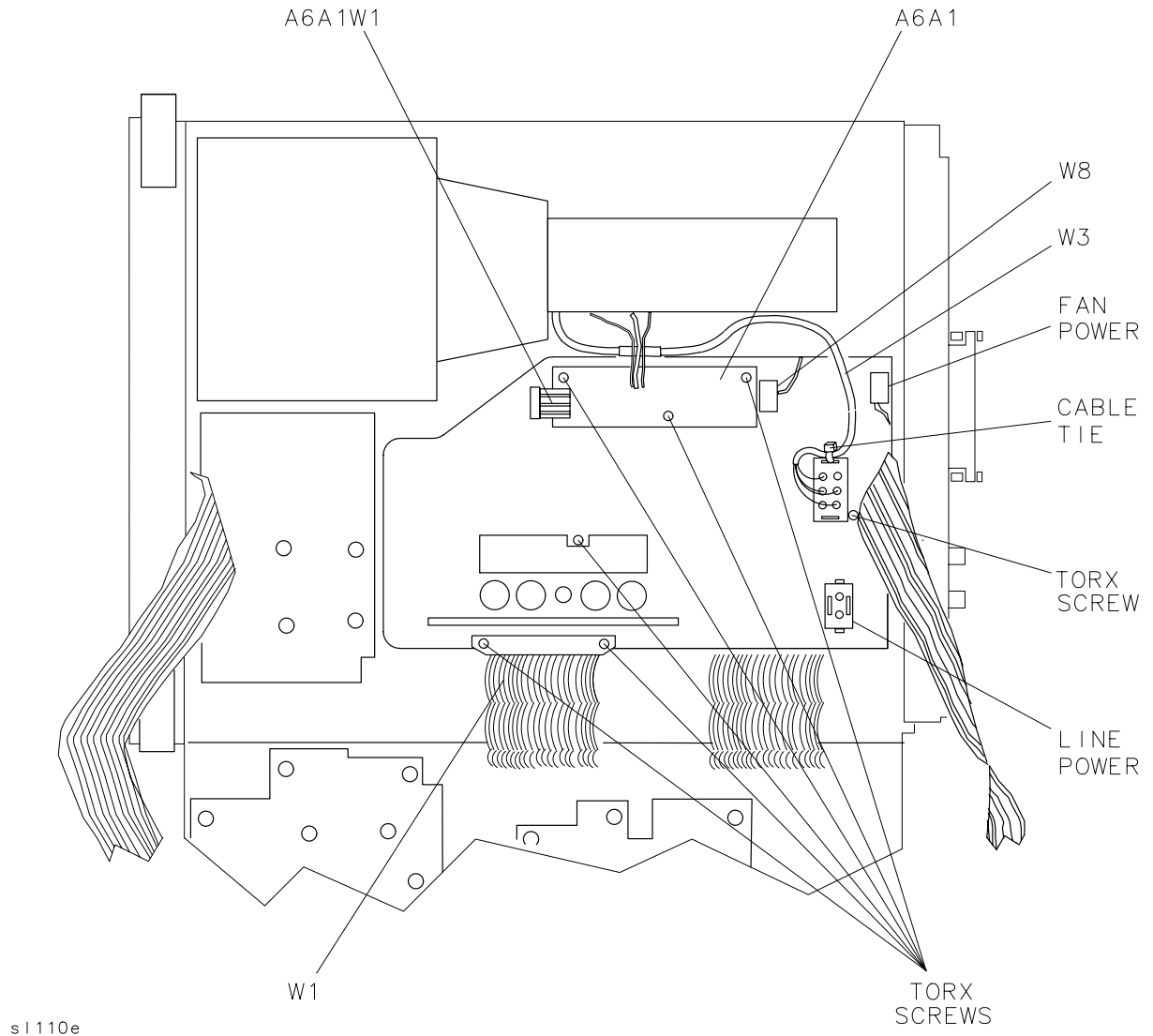

s1110e

6. Ensure that all cables are safely routed and will not be damaged when securing the A6 cover.
7. Secure the power supply cover shield to the power supply using three flathead screws (1). See [Figure 3-18 on page 184](#). One end of the cover fits into a slot provided in the rear frame assembly. Ensure that the extended portion of the cover shield is seated in the shield

wall groove.

8. Fold the A2, A3, A4, and A5 assemblies into the spectrum analyzer as described in steps 6 through 12 under "Procedure 5. A2, A3, A4, and A5 Assemblies Replacement."

Figure 3-18 Power Supply Cover

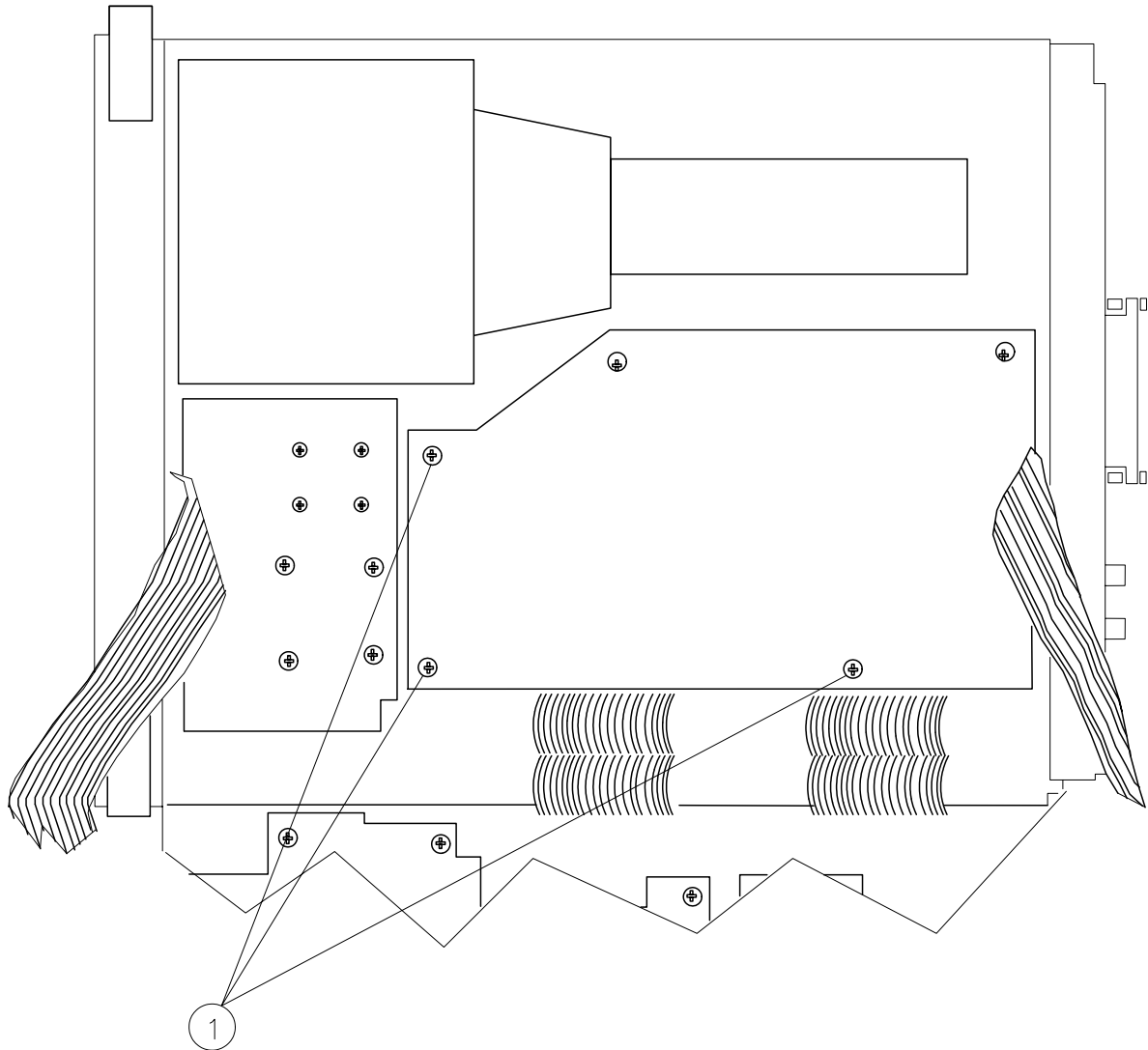

Procedure 7. A6A1 High Voltage Assembly (8560E only)

Removal

WARNING

The A6 power supply and A6A1 high voltage assemblies contain lethal voltages with lethal currents in all areas. Use extreme care when servicing these assemblies. Always disconnect the power cord from the instrument before beginning this replacement procedure. Failure to follow this precaution can represent a shock hazard which may result in personal injury.

1. Disconnect the power cord from the spectrum analyzer.
2. Remove the spectrum analyzer cover assembly as described in "Procedure 1. Spectrum Analyzer Cover."
3. Fold out the A2, A3, A4, and A5 assemblies as described in "Procedure 5. A2, A3, A4, and A5 Assemblies."
4. Place the spectrum analyzer top-side-up on the workbench.

WARNING

The voltage potential at A6A1W3 is +9 kV. Disconnect at the CRT with caution! Failure to properly discharge A6A1W3 may result in *severe electrical shock* to personnel and damage to the instrument.

5. Connect the spectrum analyzer line-power cord to provide proper grounding while discharging the A6A1W3 post-accelerator cable. Make sure that the spectrum analyzer line-power switch is in the off position.
6. Connect a high voltage probe (1000:1), such as the HP 34111A to a voltmeter with a 10 megohm input.
7. Connect the clip lead of the probe (ground) to the chassis of the spectrum analyzer.
8. Slip the tip of the high voltage probe under the A6A1W3 post-accelerator cable rubber shroud to obtain a reading on the voltmeter. See [Figure 3-3 on page 162](#).
9. Keep the high voltage probe on the post-accelerator connector until the voltage has dropped to a voltmeter reading of less than 5 mV (less than 5 V at the connector). This normally takes about 30 seconds.
10. Disconnect the line-power cord from the spectrum analyzer.
11. Using a small screwdriver with the shank in contact with the CRT

shield assembly, slip the tip of the screwdriver under the A6A1W3 post-accelerator cable rubber shroud and short the cable to ground on the CRT shield assembly. See [Figure 3-3 on page 162](#).

12. Pry out the black grommet protecting post-accelerator cable A6A1W3 from the CRT shield assembly.
13. Carefully unsnap the A6A1W3 post-accelerator cable from the CRT and discharge it by shorting the cable to chassis ground on the CRT shield assembly.
14. Remove the three screws securing the power supply shield to the power supply and remove the shield.
15. Remove the three screws securing the A6A1 high voltage assembly to the A6 power supply assembly.
16. Disconnect ribbon cable A6A1W1 from A6J5. See [Figure 3-17 on page 183](#).
17. *For Option 007 spectrum analyzers:* Remove the two screws (1) securing two board-mounting posts to the left side frame and remove the posts. See [Figure 3-19 on page 187](#).
18. Remove the two left side frame screws (2) securing the A17 assembly (and A16 assembly in Option 007). *For Option 007 spectrum analyzers:* Lift up the A16 FADC assembly and swing it out of the spectrum analyzer. Do not remove any cables.
19. Lift up the A17 CRT driver assembly and disconnect A6A1W2 from A17J6. Do not remove any other cables from the A17 assembly.
20. Disconnect the tie wraps from the A6A1 assembly cables and remove the A6A1 high voltage assembly from the spectrum analyzer.

Figure 3-19 A17 CRT Driver Mounting Screws

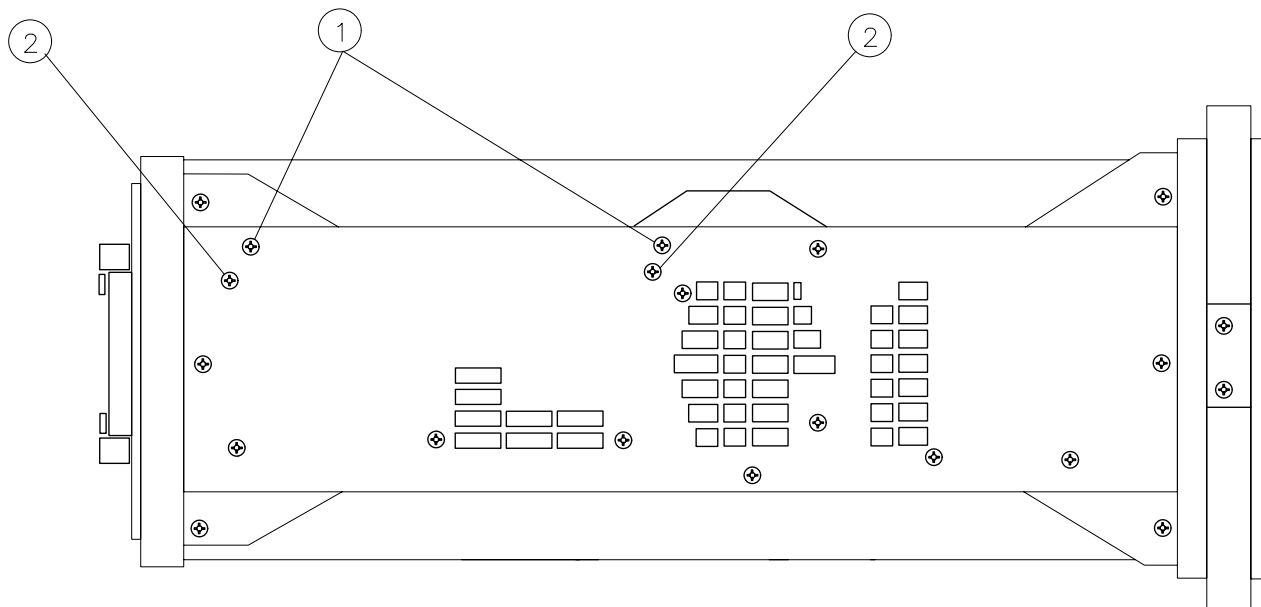

s 1115

Replacement

1. Secure the A6A1 high voltage assembly to the A6 power supply using three panhead screws. Connect ribbon cable A6A1W1 to A6J5.
2. Snap post-accelerator cable A6A1W3 to the CRT assembly.
3. Place the black grommet protecting the post-accelerator cable into the CRT shield.
4. Ensure that all cables are safely routed and will not be damaged when securing the A6 cover.
5. Secure the power supply cover shield to the power supply using three flathead screws (1). See [Figure 3-18 on page 184](#). One end of the cover fits into a slot provided in the rear frame assembly. Ensure that the extended portion of the cover shield is seated in the shield wall groove.
6. Connect A6A1W2 to A17J6.
7. Place the A17 CRT Driver assembly into the center-deck mounting slot nearest the CRT. Use caution when routing cables to avoid damage.
8. *For Option 007 spectrum analyzers:* Place the A16 FADC assembly into the center-deck mounting slot nearest the left side frame.

Ensure that the A16 FADC assembly is properly seated in the right end of the slot.

9. Secure the A17 assembly (and A16 assembly in Option 007) with the two flathead screws removed in step 18 under "Removal." See [Figure 3-19 on page 187](#) (2).
10. *For Option 007 spectrum analyzers:* Connect the two mounting posts to the left side frame using the two screws removed in step 17 under "Removal." See [Figure 3-19 on page 187](#) (1).
11. Fold the A2, A3, A4, and A5 assemblies into the spectrum analyzer and secure the spectrum analyzer cover assembly as described in "Procedure 5. A2, A3, A4, and A5 Assemblies."

Procedure 8. A7 through A13 Assemblies

A separate replacement procedure is supplied for each assembly listed below. Before beginning a procedure, do the following:

CAUTION

Turn off the spectrum analyzer power when replacing any of the following assemblies. Failure to turn off the power may result in damage to the assembly being removed.

Fold out the A14 and A15 assemblies as described in "Procedure 9. A14 and A15 assemblies."

If the A11 YTO or A10 tracking generator (Option 002) assembly is being removed, also fold down the A2, A3, A4, and A5 assemblies as described in "Procedure 5. A2, A3, A4, and A5 assemblies."

- A7 First LO Distribution Amplifier
- A8 Low Band Mixer
- A9 Input Attenuator
- A10 Tracking Generator (Option 002)
- A11 YTO
- A13 Second Converter

[Figure 3-20 on page 190](#) illustrates the location of the assemblies and [Figure 3-21 on page 191](#) provides the colors and locations of the assembly bias wires.

NOTE

Use a torque wrench (HP part number 8710-1655) to tighten all SMA connectors to 113 Ncm (10 in-lb). The style of the torque wrench may vary, but in all cases do not tighten the connectors beyond the point at which the torque wrench "clicks" or "breaks-away."

Figure 3-20 **Assembly Locations**

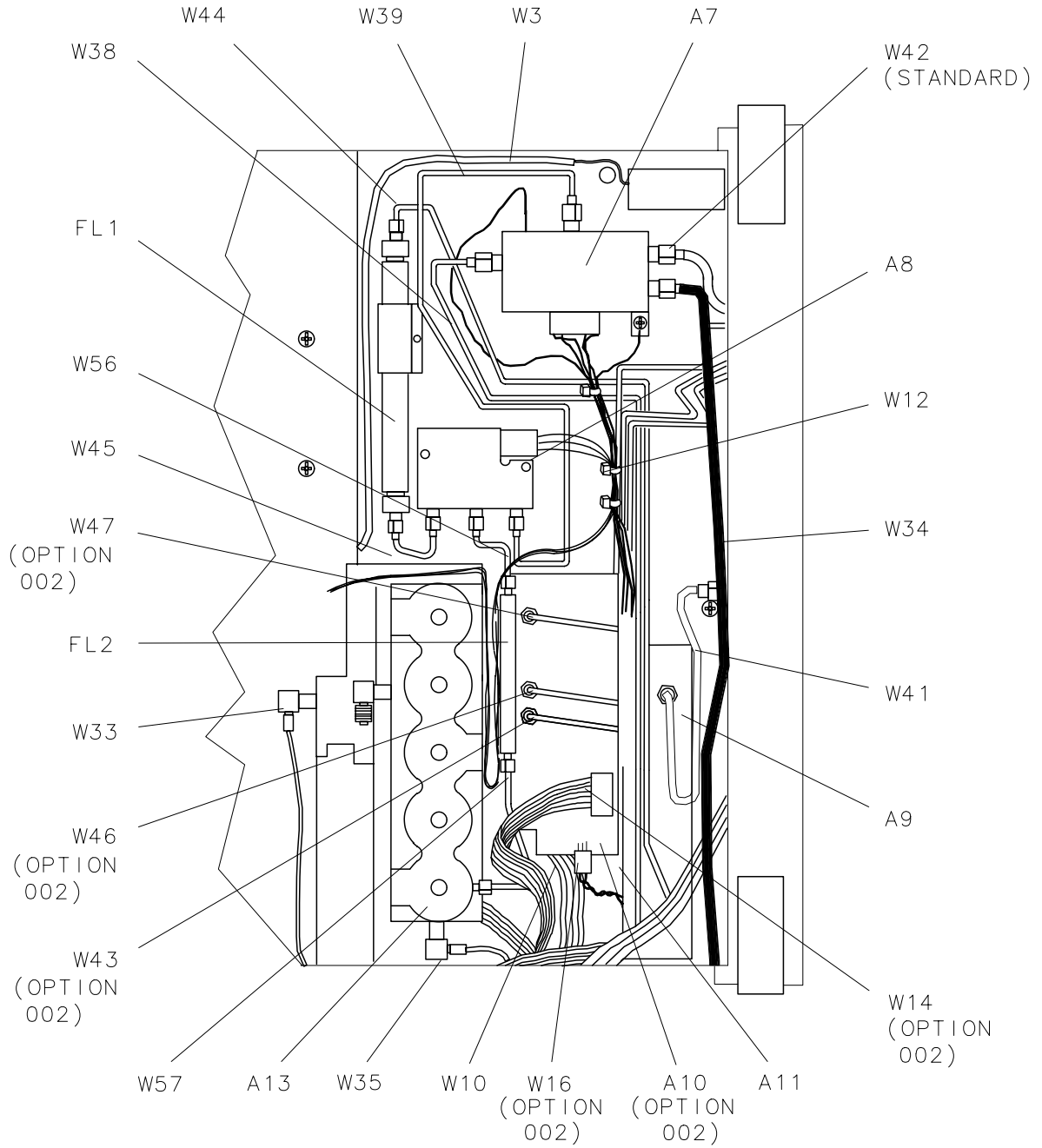
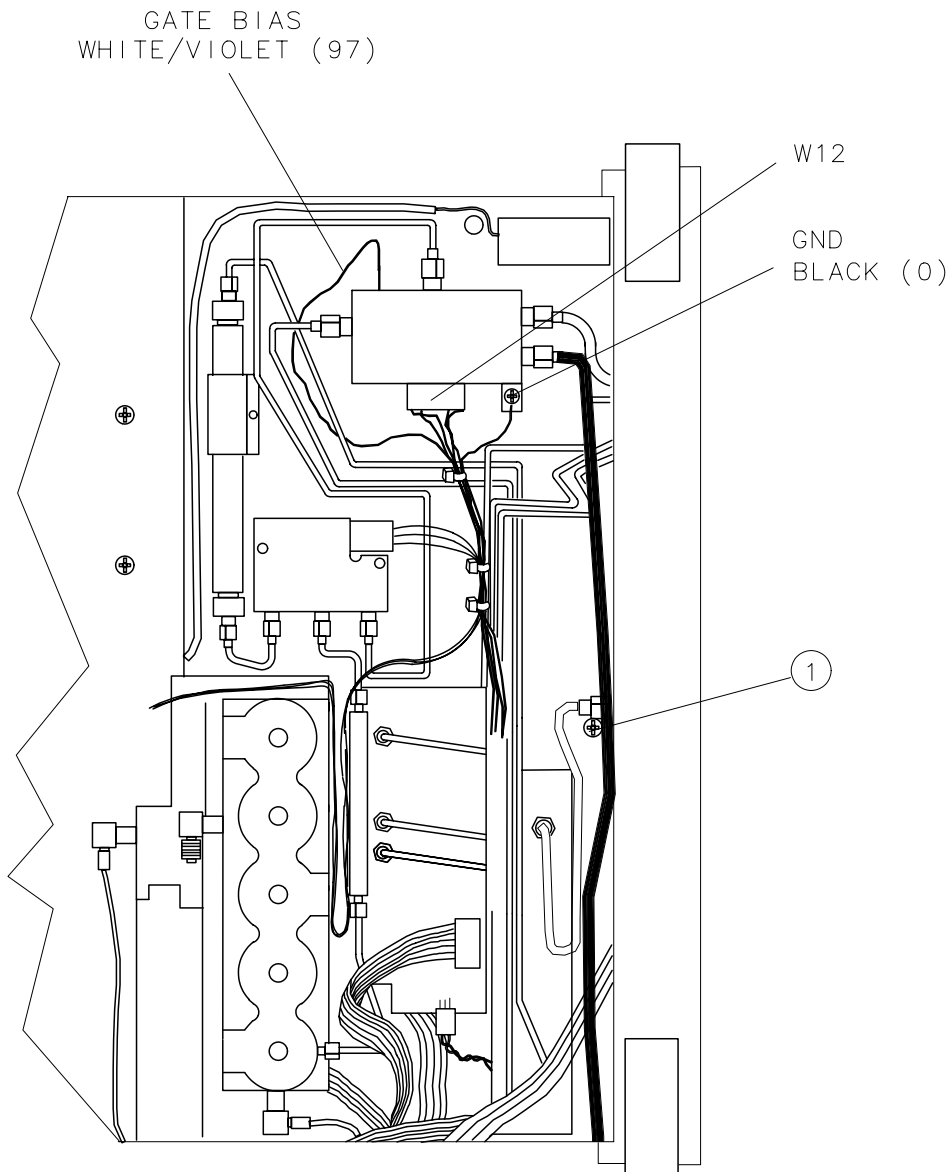

Figure 3-21 RF Section Bias Connections



A7 1st LO Distribution Amplifier

Removal

1. Remove the two screws securing the assembly to the spectrum analyzer center deck.
2. Use a 5/16-inch wrench to disconnect W38 and W39 at A7J1 and J2.
3. Disconnect W42 (W43 on Option 002) at the front panel 1ST LO OUTPUT connector. Loosen W42 (W43 on Option 002) at A7J3.

4. Remove the gate bias wire, color code 97, and W12 from the A7 assembly.
5. Remove the assembly and disconnect W34.

Replacement

1. Use a 5/16-inch wrench to attach W34 to A7J4 and W42 (W43 on Option 002) to A7J3.
2. Connect gate bias wire, color code 97, to the A7 gate bias connection next to A7J2.
3. Connect cable W12 to the A7 assembly.
4. Place gate bias wire, color code 97, beneath W38 and connect W38 to A7J1. Connect W42 (W43 on Option 002) to the front panel 1ST LO OUTPUT connector. Connect W39 to A7J2.
5. Use two panhead screws to secure A7 to the center deck. Be sure to attach the ground lug on the screw next to A7J4.
6. Torque all SMA RF cable connectors to 113 Ncm (10 in-lb).

A8 Low Band Mixer

Removal

1. Use a 5/16-inch wrench to remove W45 from FL1 and A8J1.
2. Loosen the semi-rigid coax cable connections at A8J2 and A8J3.
3. Remove the two screws securing A8 to the center deck.
4. Remove all semi-rigid coax cables from the A8 assembly.

Replacement

1. Place A8 on the center deck and attach all semi-rigid cables, starting with A8J3. Use caution to avoid damaging any of the cables' center conductor pins.
2. Use two panhead screws to secure A8 to the center deck. Reconnect W45 to FL1 and A8.
3. Torque all semi-rigid coax connections on A8 to 113 Ncm (10 in-lb). Ensure that all cable connections are tight.

A9 Input Attenuator

Removal

1. Place the spectrum analyzer upside-down on the workbench.
2. Remove W41 and disconnect W44 from the attenuator.

3. Remove screw (1) securing the attenuator to the front frame center support. See [Figure 3-21 on page 191](#).
4. Remove screw (1) securing the A9 input attenuator to the right side frame. See [Figure 3-22 on page 193](#).
5. Remove the attenuator and disconnect the attenuator ribbon cable.

Replacement

1. Connect the attenuator-control ribbon cable to the A9 input attenuator.
2. Place the A9 input attenuator into the spectrum analyzer with the A9 mounting brackets resting against the front frame center support and the right side frame. Use caution to avoid damaging any cables.
3. Attach the attenuator to the center support with one panhead screw (1). See [Figure 3-21 on page 191](#).
4. Attach the attenuator to the right side frame, using one flathead screw (1). See [Figure 3-22 on page 193](#).
5. Connect semi-rigid cables W41 and W44 to the attenuator assembly. Connect opposite end of W41 to the front frame. Torque all SMA connectors to 113 Ncm (10 in-lb).

Figure 3-22 A9 Mounting Screws at Right Frame

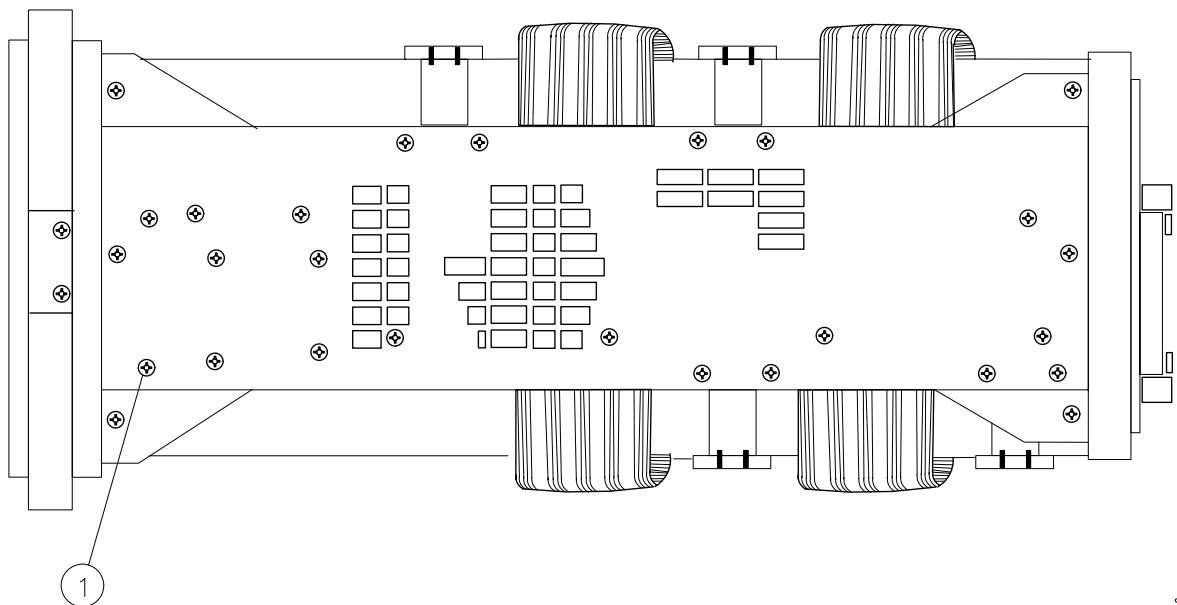

s 1113

A10 Tracking Generator (Option 002)

Removal

1. Use a 5/16-inch wrench to remove the A10 tracking generator RF OUT, LO OUT, and LO IN semi-rigid cables.
2. Disconnect W14 and W16 from the A10 tracking generator.
3. Remove the three screws (1) securing the A10 tracking generator to the center deck. These screws are located on the top side of the center deck as illustrated in [Figure 3-23 on page 194](#).
4. Remove the A10 tracking generator and disconnect W48, coax 80.

Figure 3-23 A10 Tracking Generator Mounting Screws

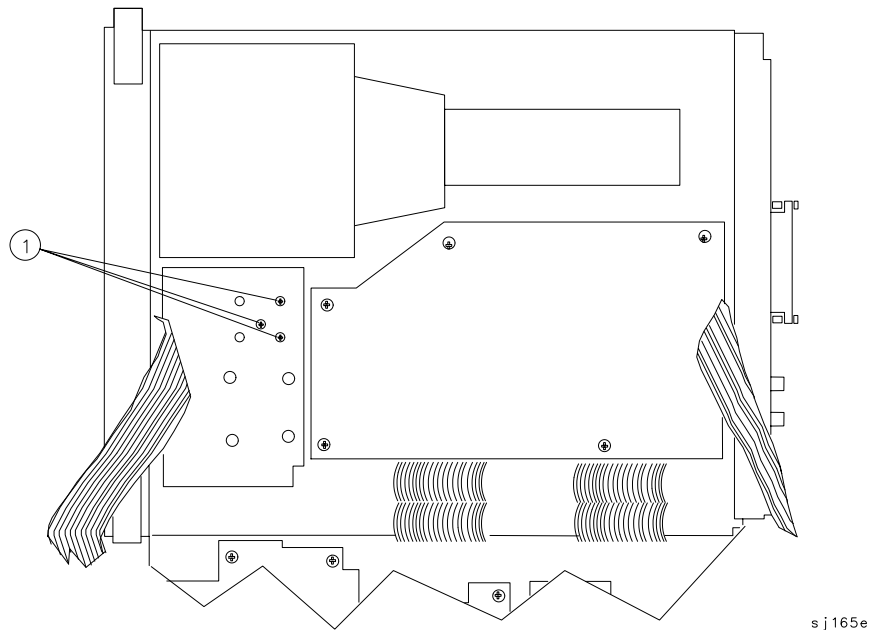

Replacement

1. Connect W48, coax 80, to the A10 tracking generator INPUT connector.
2. Orient the tracking generator so that its LO IN, LO OUT, and RF OUT connectors are closest to the A13 Second Converter.
3. Loosely connect the LO IN, LO OUT, and RF OUT semi-rigid cables.
4. Secure the A10 tracking generator to the spectrum analyzer center

- deck using the three screws removed in step 3 under "Removal."
5. Torque the semi-rigid cables to 113 Ncm (10 in-lb).
 6. Connect W14 and W16 to the A10 tracking generator.

A11 YTO

Removal

1. If the spectrum analyzer is an Option 002, remove the A10 tracking generator before proceeding.
2. Place the spectrum analyzer top-side-down on the workbench.
3. Use a 5/16-inch wrench to remove W56/FL2/W57 (as a unit).
4. Disconnect W38 at the A11 assembly.
5. Remove the A11 mounting screws (1) shown in [Figure 3-24 on page 195](#).
6. Disconnect W10 from A11.

Figure 3-24 A11 Mounting Screws

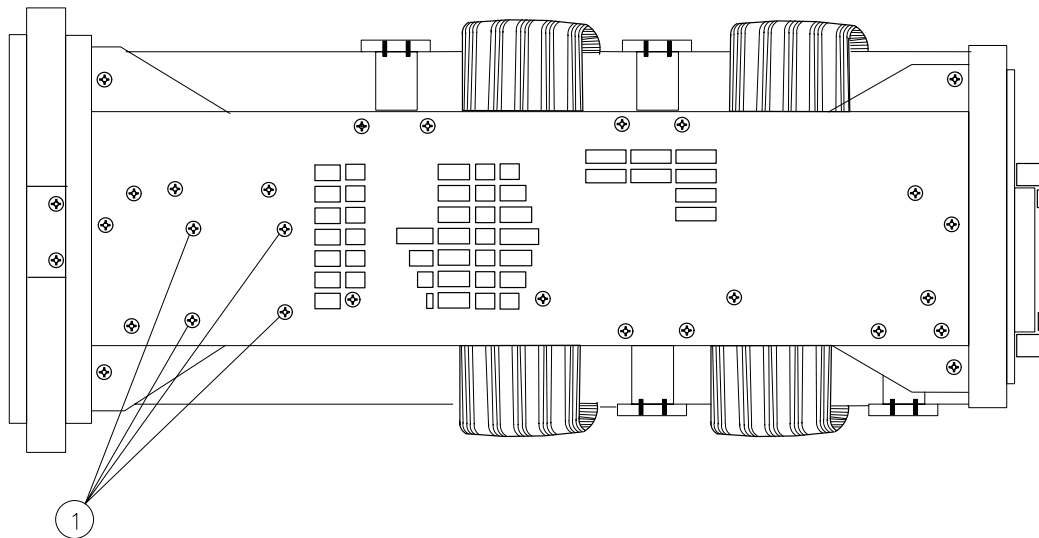

s1114e

Replacement

1. Reconnect W10 to A11.
2. Place the A11 assembly in the spectrum analyzer.
3. Secure the A11 assembly to the right side frame using the four screws (1) removed in step 5 under "Removal."

4. Connect W38 to A11.
5. Install W56/FL2/W57. Ensure that all of the connections are tight. Torque all SMA connectors to 113 Ncm (10 in-lb).
6. If the spectrum analyzer is an Option 002, install the A10 tracking generator.

A13 Second Converter

CAUTION

Turn off the spectrum analyzer power when replacing the A13 second converter assembly. Failure to turn off the power may result in damage to the assembly.

Removal

1. Place the spectrum analyzer upside-down on the workbench.
2. Disconnect W33, coax 81, and W35, coax 92, from the A13 assembly.
3. *For Option 002 instruments:* Disconnect W48, coax 8, from A13J3.
4. Disconnect W57 from A13J1.
5. Remove the four screws securing A13 to the main deck and remove the assembly.
6. Disconnect ribbon cable W13 from the A13 assembly.

Replacement

1. Connect ribbon cable W13 to the A13 assembly.
2. Secure A13 to the spectrum analyzer main deck, using four panhead screws.
3. Connect W33, coax 81, to A13J4 600 MHz IN jack.
4. Connect W35, coax 92, to A13J2 310.7 MHz OUT jack.
5. *For Option 002 instruments:* Connect W48, coax 8, to A13J3. Route W48 under W35, coax 92.
6. Connect W57 to A13J1. Ensure that all of the cable connections are tight. Torque all SMA cable connectors to 113 Ncm (10 in-lb).

Procedure 9. A14 and A15 Assemblies

Removal

1. Remove the spectrum analyzer cover as described in "Procedure 1. Spectrum Analyzer Cover."
2. Place the spectrum analyzer on its right side frame.
3. Remove the eight screws (1) holding the A14 and A15 assemblies to the bottom of the spectrum analyzer. See [Figure 3-25 on page 197](#)

Figure 3-25 A14 and A15 Assembly Removal

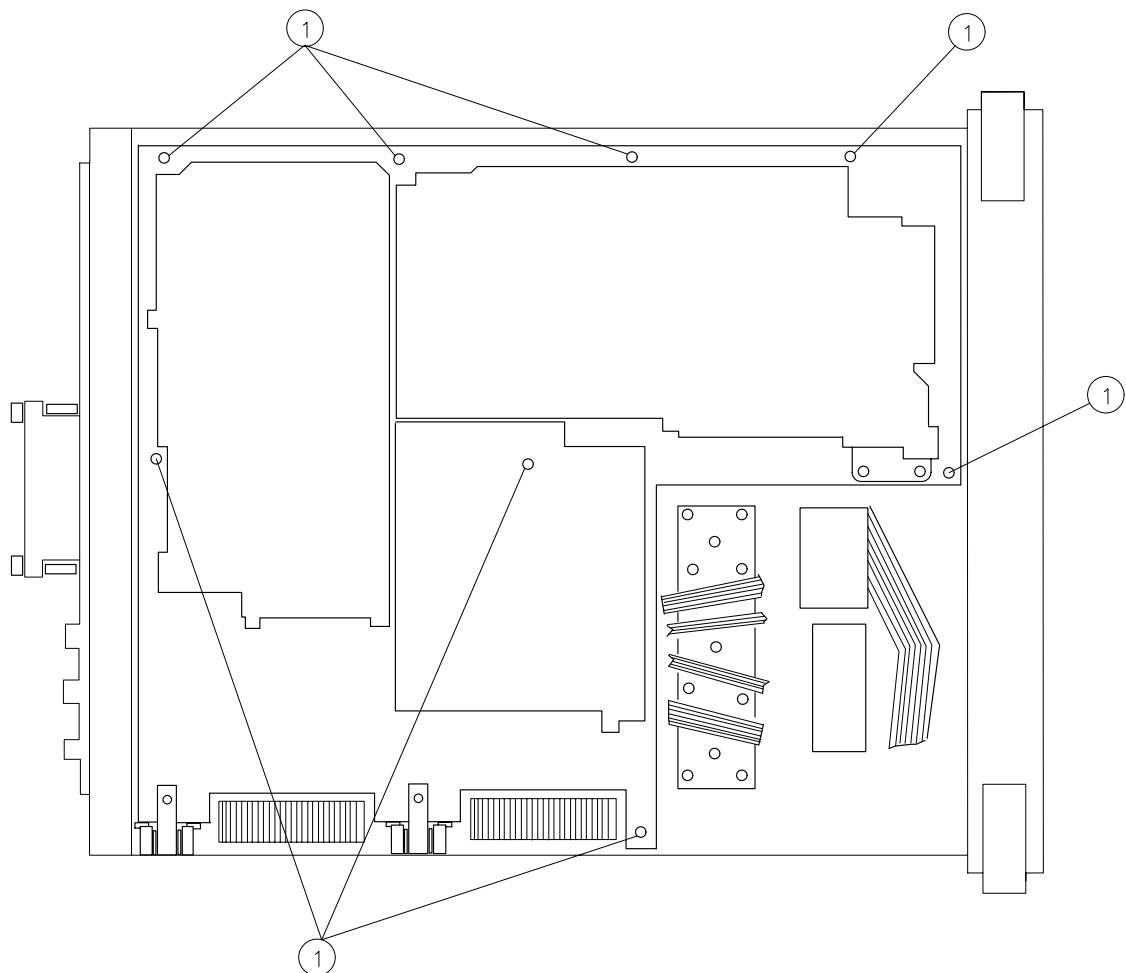

s1112e

CAUTION

DO NOT fold the board assemblies out of the spectrum analyzer one at a time. Always fold the A14 and A15 assemblies as a unit. Folding out one assembly at a time binds the hinges attaching the assemblies and may damage an assembly and hinge.

4. The board assemblies are attached to the spectrum analyzer right side frame with two hinges. Fold both the A14 and A15 assemblies out of the spectrum analyzer as a unit.
5. Remove all cables from the assembly being removed.
6. Remove the two screws that attach the assembly being removed to its two mounting hinges.

CAUTION

DO NOT torque shield screws to more than 8 inch-pounds. Applying excessive torque will cause the screws to stretch.

Replacement

1. Attach the removed assembly to the two chassis hinges with two panhead screws.
2. Attach all cables to the assembly as illustrated in [Figure 3-26 on page 199](#). When connecting W34 to A15, torque the SMA connector to 113 Ncm (10 in-lb).
3. Lay the A14 and A15 assemblies flat against each other in the folded out position. Make sure that no cables become pinched between the two assemblies. Ensure that all coaxial cables are clear of hinges and standoffs before continuing onto the next step.
4. Fold both board assemblies into the spectrum analyzer as a unit. Use caution to avoid damaging any cable assemblies.
5. Secure the assemblies using the eight screws removed in step 3 under "Removal." See [Figure 3-25 on page 197](#).
6. Secure the spectrum analyzer cover assembly as described in "Procedure 1. Spectrum Analyzer Cover."

Figure 3-26 A14 and A15 Assembly Cables

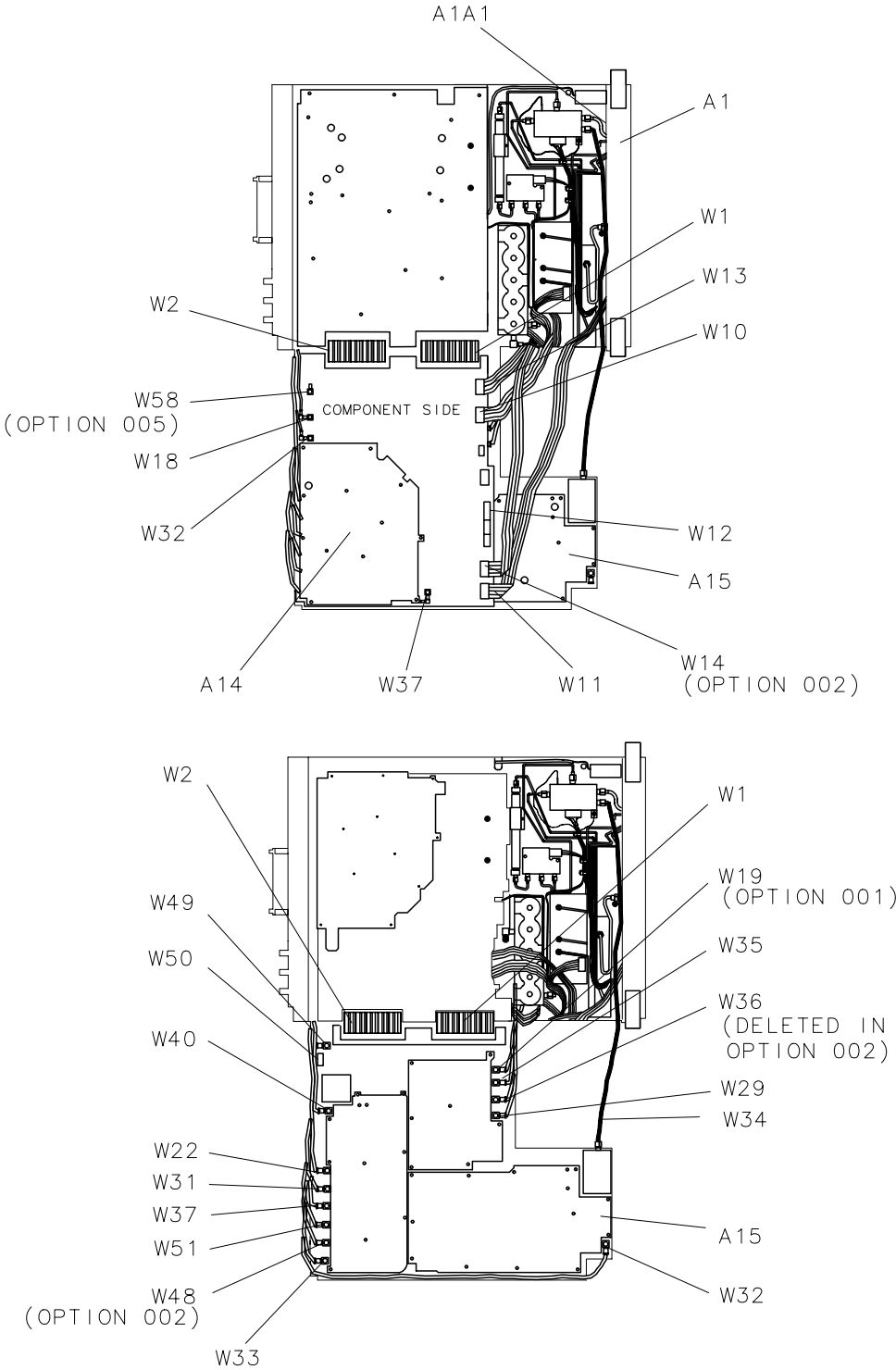

sj1132e

Procedure 10. A16 FADC/A17 CRT Driver (8560E)

Removal

1. Remove the spectrum analyzer cover assembly and fold out the A2, A3, A4, and A5 assemblies as described in steps 3 through 6 under "Procedure 5. A2, A3, A4, and A5 Assemblies Removal."
2. Place the spectrum analyzer top-side-up on the workbench with A2, A3, A4, and A5 folded out to the right.
3. *For Option 007 spectrum analyzers:* Remove two screws (1) securing the two board-mounting posts to the left side frame, and remove the posts. See [Figure 3-27 on page 201](#).
4. Remove two screws (2) securing the A17 assembly (and A16 assembly in Option 007) to the left side frame. Remove the two spacers (non-Option 007).
5. Pull the A17 assembly out of the spectrum analyzer.
6. *For Option 007 spectrum analyzers:* Pull the A16 assembly out of the spectrum analyzer.
7. Disconnect W7, W8, W9, A6A1W2, and A18W1 from the A17 CRT driver assembly.
8. *For Option 007 spectrum analyzers:* Disconnect all cables from the A16 FADC assembly.

Figure 3-27 A16 and A17 Mounting Screws

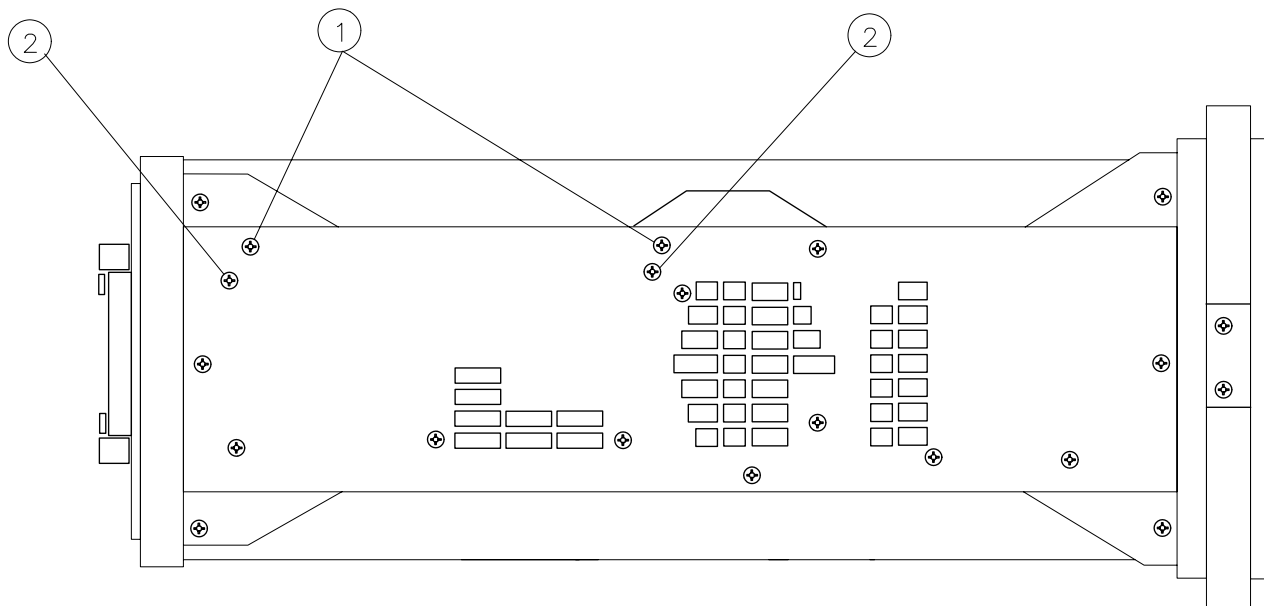

s | 115

Replacement

1. Connect W7, W8, W9, A6A1W2, and A18W1 to the A17 CRT driver assembly. Place the assembly into the center-deck mounting slot next to the CRT assembly.
2. *For Option 007 spectrum analyzers:* Connect all A16 assembly cables as illustrated in [Figure 3-28 on page 202](#) which shows the left side frame removed so that proper A16 assembly cable routing may be viewed. Place the A16 assembly into the center-deck mounting slot nearest the left side frame.
3. Secure the A17 assembly (and A16 assembly in Option 007) to the left side frame using two flathead screws (and two spacers in non-Option 007). *For Option 007:* Attach the board mounts to the left side frame using two flathead screws (1). See [Figure 3-27 on page 201](#).
4. Place the spectrum analyzer on its right side frame.
5. Fold the A2, A3, A4, and A5 assemblies into the spectrum analyzer as described in "Procedure 5. A2, A3, A4, and A5 Assemblies." Secure the spectrum analyzer cover assembly.

Figure 3-28 **A16 Cable Routing**

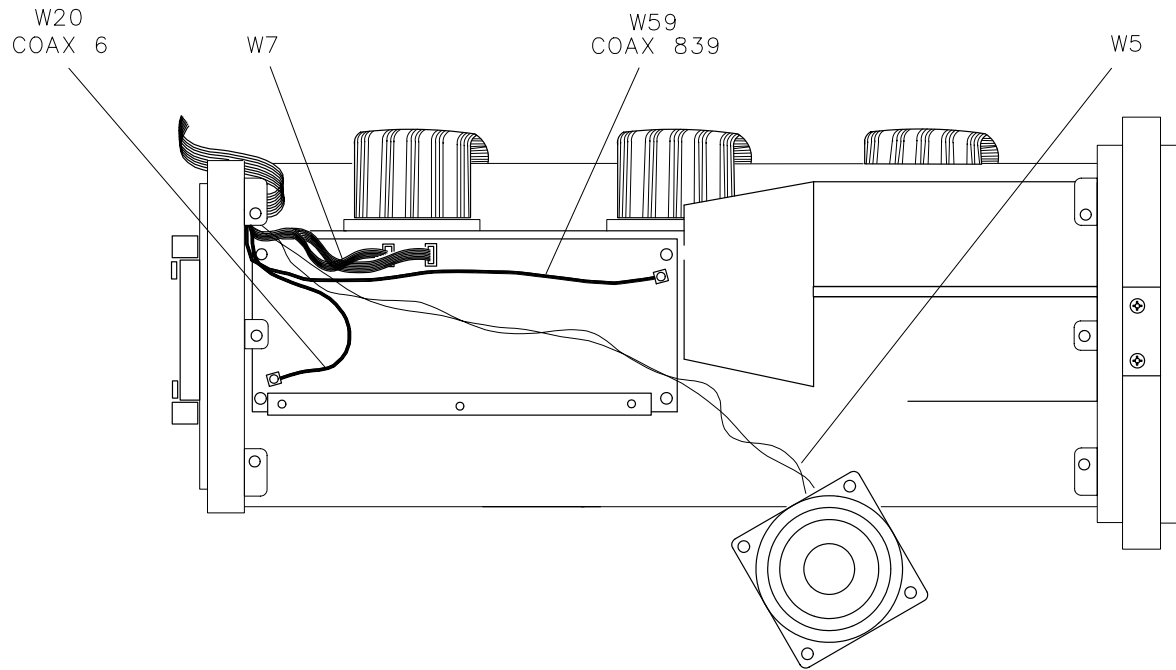

sj138e

Procedure 11. B1 Fan

Removal/Replacement

WARNING

Always disconnect the power cord from the instrument before beginning this replacement procedure. Failure to follow this precaution can present a shock hazard which may result in personal injury.

1. Remove the four screws securing the fan assembly to the rear frame.
2. Remove the fan and disconnect the fan wire from the A6 Power Supply assembly.
3. To reinstall the fan, connect the fan wire to A6J3 and place the wire into the channel provided on the left side of the rear frame opening. Secure the fan to the rear frame using four panhead screws.

NOTE

The fan must be installed so that the air enters through the front and sides of the instrument and exits out the rear of the instrument.

Procedure 12. BT1 Battery

WARNING

Battery BT1 contains lithium polycarbon monofluoride. Do not incinerate or puncture this battery. Dispose of discharged battery in a safe manner.

CAUTION

To avoid loss of the calibration constants stored on the A2 Controller assembly, connect the spectrum analyzer to the main power source and turn on before removing the battery.

The battery used in this instrument is designed to last several years. An output voltage of +3.0 V is maintained for most of its useful life. Once this voltage drops to +2.6 V, its life and use are limited and the output voltage will deteriorate quickly. When the instrument is turned off, stored states and traces will only be retained for a short time and may be lost. Refer to "State- and Trace-Storage Problems" in Chapter 9, "Controller Section," in this manual. The battery should be replaced if its voltage is +2.6 V or less.

Removal/Replacement

1. Remove any option module attached to the rear panel.
2. Locate the battery assembly cover on the spectrum analyzer rear panel. Use a screwdriver to remove the two flathead screws securing the cover to the spectrum analyzer.
3. Remove the old battery and replace it with the new one, ensuring proper polarity.
4. Measure the voltage across the new battery. Nominal new battery voltage is approximately +3.0 V. If this is not the case, check the battery cable and A2 Controller assembly.
5. Secure the battery assembly into the spectrum analyzer.

Procedure 13. Rear Frame/Rear Dress Panel

Removal

WARNING

The A6 power supply (in E-series and EC-series instruments) and the A6A1 high voltage (in E-series instruments) assemblies contain lethal voltages with lethal currents in all areas. Use extreme care when servicing these assemblies. Always disconnect the power cord from the instrument before beginning this replacement procedure. Failure to follow this precaution can present a shock hazard which may result in personal injury.

NOTE

Diagrams that illustrate features common to E-series and EC-series instruments are shown with E-series instruments. Where features differ for E-series and EC-series instruments, separate diagrams are provided.

1. Disconnect the line-power cord from the spectrum analyzer.
2. Remove the spectrum analyzer cover, and place the spectrum analyzer on its right side frame.
3. Fold out the A2, A3, A4, and A5 assemblies as described in "Procedure 5. A2, A3, A4, and A5 Assemblies Removal," steps 3 through 5.
4. Disconnect the HP-IB cable at A2J5.
5. Place the spectrum analyzer top-side-up on the work bench with A2 through A5 folded out to the right.

For EC-series instruments, proceed to step 13. For E-series instruments proceed to step 6.

WARNING

The voltage potential at A6A1W3 is +9 kV. Disconnect at the CRT with caution! Failure to properly discharge A6A1W3 may result in severe electrical shock to personnel and damage to the instrument.

6. Connect the spectrum analyzer line-power cord to provide proper grounding while discharging the A6A1W3 post-accelerator cable. Make sure that the spectrum analyzer line-power switch is in the off position.

7. Connect a high-voltage probe (1000:1), such as the HP 34111A to a voltmeter with a 10 megohm input.
8. Connect the clip lead of the probe (ground) to the chassis of the spectrum analyzer.
9. Slip the tip of the high-voltage probe under the A6A1W3 post-accelerator cable's rubber shroud to obtain a reading on the voltmeter. See [Figure 3-3](#).
10. Keep the high-voltage probe on the post-accelerator connector until the voltage has dropped to a voltmeter reading of less than 5 mV (less than 5 V at the connector). This normally takes about 30 seconds.
11. Disconnect the line-power cord from the spectrum analyzer.
12. Using a small screwdriver with the shank in contact with the CRT shield assembly, slip the tip of the screwdriver under the A6A1W3 post-accelerator cable's rubber shroud and short the cable to ground on the CRT shield assembly. See [Figure 3-3](#).
13. Remove the three screws securing the power-supply shield to the power supply, and remove the shield. See (1) in [Figure 3-30](#).
14. Disconnect the fan and line-power cables from A6J3 and A6J101 on the A6 power supply assembly.
15. Remove the two flathead screws that secure the rear-panel battery assembly, and remove the assembly. Remove the battery and unsolder the two wires attached to the battery assembly.
16. Use a 9/16-inch nut driver to remove the dress nuts holding the BNC connectors to the rear frame. If necessary, drill out the nut driver to fit over the BNC connectors, and cover it with heatshrink tubing or tape to avoid scratching the dress panel.
17. Remove four screws that secure the rear frame to the main deck. See (1) in [Figure 3-29](#).
18. Remove the six screws that secure the rear frame to the left and right side frames.
19. Remove the knurled nut that secures the earphone jack. Carefully remove the jack using caution to avoid losing the lock washer located on the inside of the rear-frame assembly. Replace the washer and nut onto the jack for safekeeping.
20. Remove the rear-frame assembly.
21. To remove the rear dress panel, remove the two nuts located on the inside of the rear frame near the display adjustment holes.

Figure 3-29 Main Deck Screws

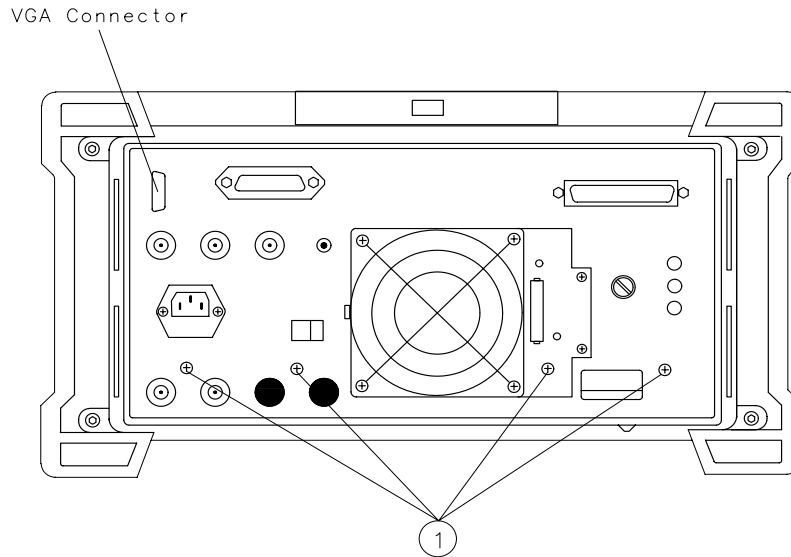

sp123c

Replacement

1. If the rear dress panel is removed, secure it to the rear frame using two nuts. Ensure that the dress panel is aligned with the frame.
2. Place the spectrum analyzer on its front panel allowing easy access to the rear-frame area.
3. Place the rear frame on the spectrum analyzer and secure the knurled nut on the earphone jack. A lock washer should be used on the inside of the rear frame and a flat washer on the outside.
4. Place the coax cable's BNC connectors into the appropriate rear-frame holes as described below. Use a 9/16-inch nut driver to attach the dress nuts holding the BNC connectors to the rear frame.

Rear Panel Jack

| EC-series | E-series | RF Cable |
|-----------|----------|--------------|
| J1 | n/a | W64 |
| n/a | J1 | W55 |
| J4 | J4 | W24, coax 5 |
| J5 | J5 | W23, coax 93 |
| J6 | J6 | W25, coax 4 |
| J7 | n/a | W55 |
| J8 | J8 | W18, coax 97 |
| J9 | J9 | W31, coax 8 |
| J11 | J11 | W58, coax 8 |

5. Secure the rear frame to the spectrum analyzer main deck, using four panhead screws (1). See [Figure 3-29](#).

6. Secure the rear frame to the spectrum analyzer side frames using three flathead screws per side. Use caution to avoid damaging any coaxial cables.
7. Place the spectrum analyzer top-side-up on the work bench.
8. Pull the red and black battery wires through the rear-frame's battery-assembly hole. Solder the red wire to the battery-assembly's positive lug and the black wire to the negative lug. Replace the battery.
9. Secure the battery assembly to the rear frame, using two flathead screws.
10. Connect the fan and line-power cables to A6J3 and A6J101 on the A6 power supply.
For EC-series instruments, proceed to step 13. For E-series instruments proceed to step 11.
11. Snap the A6A1W3 post-accelerator cable to the CRT assembly.
12. Snap the black grommet protecting A6A1W3 into the CRT shield.
13. Ensure that all cables are safely routed and will not be damaged when securing the A6 cover.
14. Secure the power-supply cover shield to the power supply, using three flathead screws (1). One end of the cover fits into a slot provided in the rear-frame assembly. Ensure that the extended portion of the cover shield is seated in the shield wall groove. See [Figure 3-30](#).
15. Connect the HP-IB cable to A2J5.
16. Fold the A2, A3, A4, and A5 assemblies into the spectrum analyzer as described in procedure 5.

Figure 3-30 **A6 Power Supply Cover**

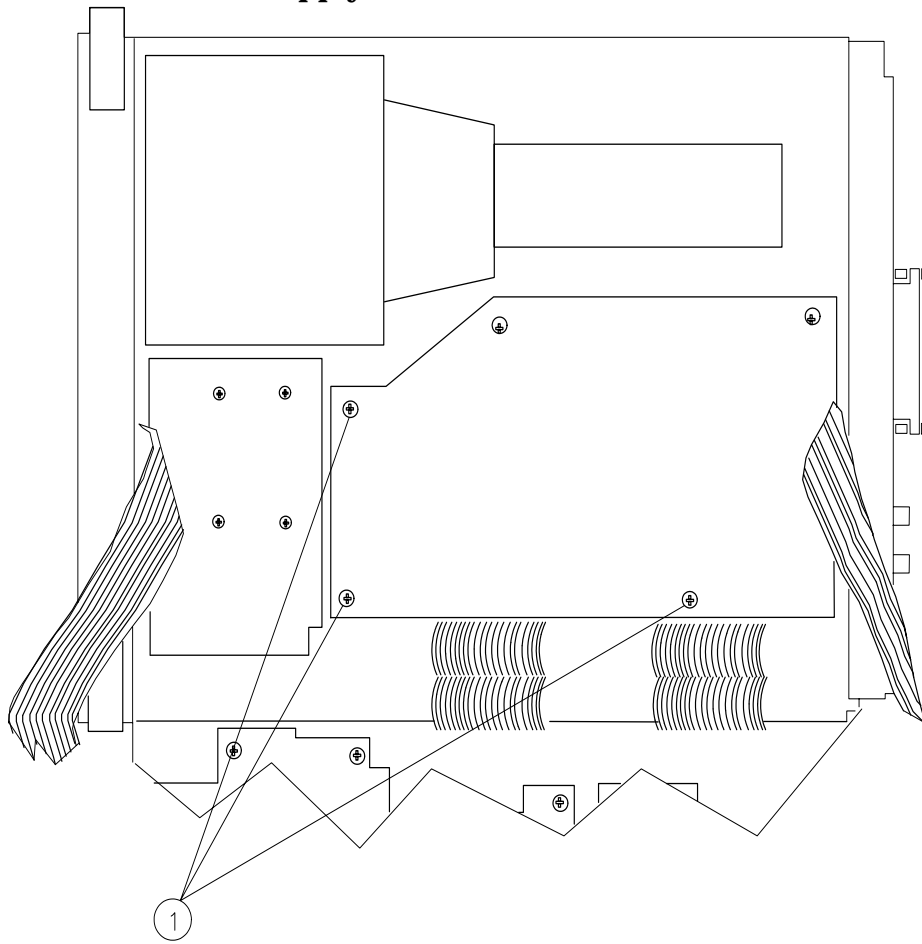

SP14E

Procedure 14. W3 Line Switch Cable (8560E)

Removal

NOTE To remove the line switch for 8560EC instruments see [“Removal of the Line Switch from the Front Panel” on page 153.](#)

WARNING **Due to possible contact with high voltages, disconnect the spectrum analyzer line-power cord before performing this procedure.**

1. Remove the spectrum analyzer cover assembly as described in "Procedure 1. Spectrum Analyzer Cover."
2. Fold out the A2, A3, A4, and A5 assemblies as described in steps 3 through 5 under "Procedure 5. A2, A3, A4, and A5 Assemblies Removal."
3. Disconnect A1A1W1 from A3J602.
4. Place the spectrum analyzer top-side-up on the workbench with A2 through A5 folded out to the right.

WARNING **The voltage potential at A6A1W3 is +9 kV. Disconnect at the CRT with caution! Failure to properly discharge A6A1W3 may result in *severe electrical shock* to personnel and damage to the instrument.**

5. Connect the spectrum analyzer line-power cord to provide proper grounding while discharging the A6A1W3 post-accelerator cable. Make sure that the spectrum analyzer line-power switch is in the off position.
6. Connect a high voltage probe (1000:1), such as the HP 34111A, to a voltmeter with a 10 megohm input.
7. Connect the clip lead of the probe (ground) to the chassis of the spectrum analyzer.
8. Slip the tip of the high voltage probe under the A6A1W3 post-accelerator cable rubber shroud to obtain a reading on the voltmeter. See [Figure 3-3 on page 162.](#)
9. Keep the high voltage probe on the post-accelerator connector until the voltage has dropped to a voltmeter reading of less than 5 mV (less than 5 V at the connector). This normally takes about 30 seconds.
10. Disconnect the line-power cord from the spectrum analyzer.

11. Using a small screwdriver with the shank in contact with the CRT shield assembly, slip the tip of the screwdriver under the A6A1W3 post-accelerator cable rubber shroud and short the cable to ground on the CRT shield assembly. See [Figure 3-3 on page 162](#).
12. Remove the three screws securing the power supply shield to the power supply, and remove the shield.
13. Pull the cable tie (1), [Figure 3-31 on page 212](#), to free W9 and the post-accelerator cables.
14. Disconnect W3 from A6J2.
15. Pull W3 up from between the power supply and the CRT assembly to release it from the cable clamp.
16. Place the spectrum analyzer on its right side frame.
17. Fold out the A14 and A15 assemblies as described in steps 3 and 4 under "Procedure 9. A14 and A15 Assemblies Removal."
18. Loosen the screw (1) securing W3, the line switch assembly, to the front frame. The screw is captive. See [Figure 3-32 on page 213](#).
19. Remove A1W1 and A1W1DS1 from the line switch assembly. Let each hang freely.

NOTE

If contact removal tool, HP part number 8710-1791, is available, complete assembly removal by performing "Removal" steps 20 and 21. If not, skip to step 23 under "Removal."

20. With wire cutters, clip the tie wrap holding the cable to the contact housing. From the top side of the spectrum analyzer, use contact removal tool, HP part number 8710-1791, to remove the four wires from the W3 connector. See [Figure 3-33 on page 214](#).
21. Completely remove the cable from the instrument.
22. Remove the A1 front frame assembly. Remove the front panel and A18 CRT assembly as described in steps 16 through 29 under "Procedure 2B. A1 Front Frame/A18 CRT (8560E)."
23. Remove the left side frame from the spectrum analyzer. See [Figure 3-34 on page 217](#). (The side frame will still be attached by the speaker wires. Do not let it hang freely.)
24. Follow these steps to remove the line switch from the front panel:
 - a. gently remove the green LCD from the top-center of the line switch assembly,
 - b. remove the two screws (0515-1521) that secure the line switch to the front frame,
 - c. remove the screw which secures the orange and the white ground

- cables for the probe power and line switch, and
- d. remove the line switch.

Figure 3-31 W3 Dress and Connection to A6 Power Supply

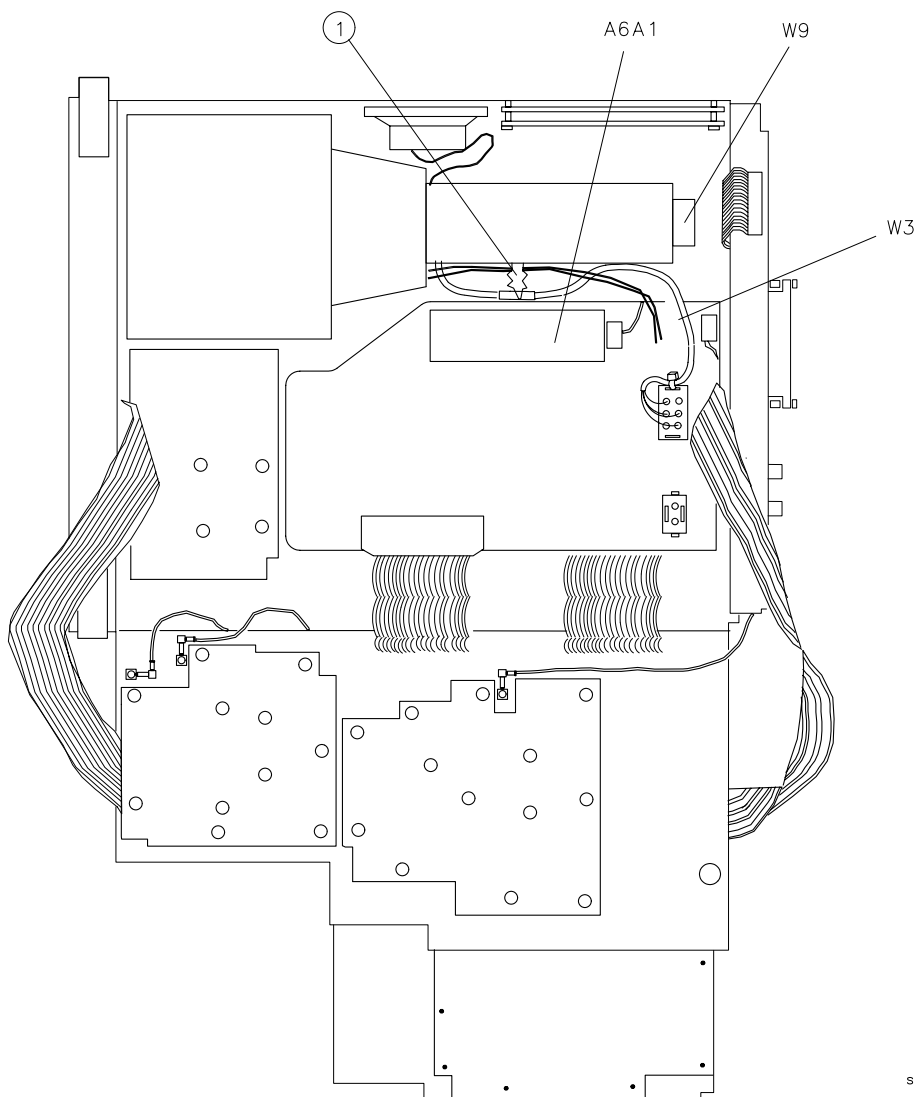

s1111e

Figure 3-32 Line Switch Mounting Screw and Cable Dress

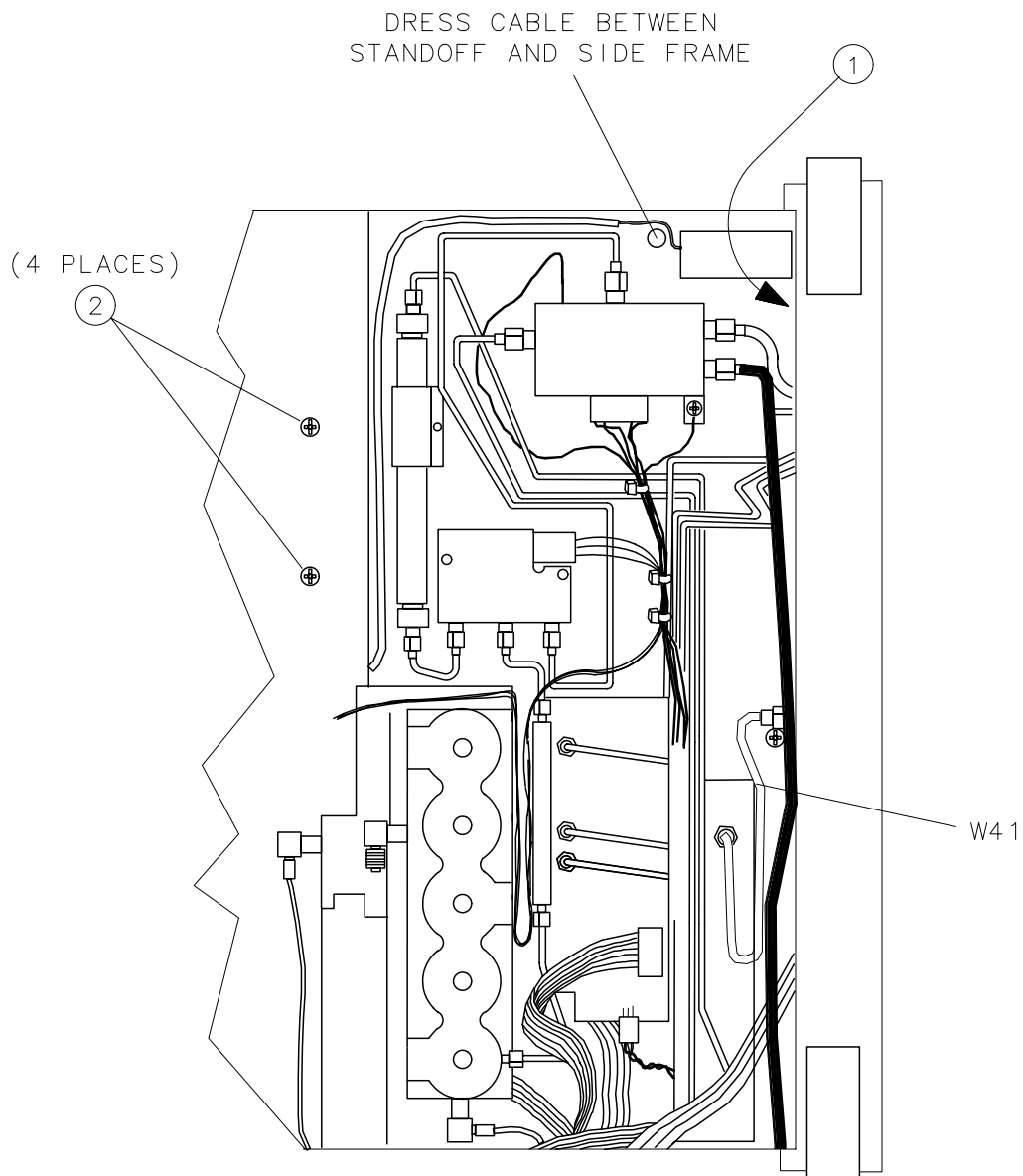
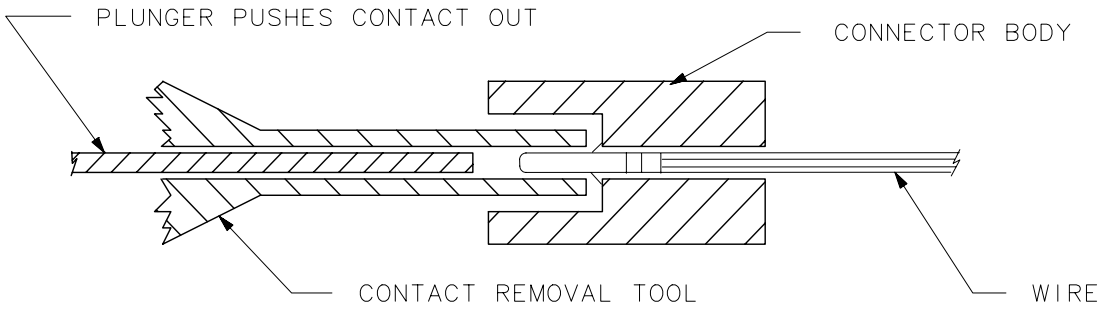
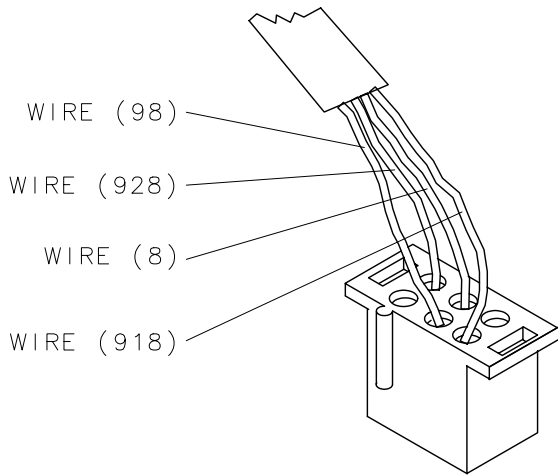
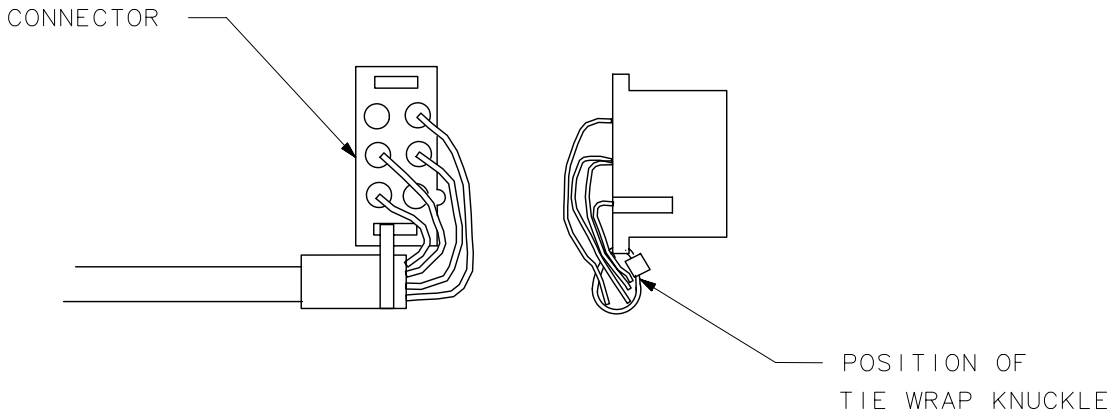

Figure 3-33 **W3 Cable Connector**



SK15

Replacement (Using Contact Removal Tool, HP Part Number 8710-1791)

1. Ensure that the action of the switch is working properly. With a pair of wire cutters, clip the tie wrap holding the cable to the contact housing of the replacement W3 assembly.
2. Using the contact removal tool, remove the four wires from the replacement cable assembly connector.
3. From the bottom side of the spectrum analyzer, insert the contact end of W3 through the slotted opening in the main deck. W3 should come through to the top side of the spectrum analyzer between the A18 CRT assembly and the post-accelerator cable.
4. Place LED A1W1DS1 into the line switch assembly.
5. Attach the line switch assembly into the front frame, using the captive panhead screw. Ensure the connection of the line switch grounding lug to the screw.
6. Dress W3 between the main deck standoff and the side frame. See [Figure 3-32 on page 213](#).
7. On the top side of the spectrum analyzer, redress W3.
8. Insert the four contacts into the W3 connector.
9. Attach the cable to the connector housing using the supplied tie wrap.
10. Connect W3 to A6J2. Dress W3 into the slotted opening in the deck.
11. Connect A1A1W1 to A3J602.
12. Secure the power supply cover shield to the power supply, using three flathead screws. One end of the cover fits into a slot provided in the rear frame assembly. Ensure that the extended portion of the cover shield is seated in the shield wall groove.
13. Redress W3 and the other cable assemblies down between the CRT assembly and the power supply cover such that the W9 wires are underneath the surface of the power supply cover.
14. Fold up the A2, A3, A4, and A5 assemblies into the spectrum analyzer as described in steps 5 through 10 under "Procedure 5. A2, A3, A4, and A5 Assemblies Replacement."
15. Fold up A14 and A15 assemblies as described in steps 9 through 11 under "Procedure 9. A14 and A15 Assemblies Replacement."

Replacement (without Contact Removal Tool)

1. Lay the replacement line switch cable assembly between the side frame and main deck. Ensure that the action of the switch is working properly.
2. Attach the left side frame to the deck and rear frame. See [Figure 3-34 on page 217](#).

| Screw | Quantity |
|--|----------|
| (1) SCREW-MACH M4 X 0.7 8 mm-LG FLAT HD | 3 |
| (2) SCREW-MACH M3 X 0.5 35 mm-LG FLAT HD | 2 |
| (3) SCREW-MACH M3 X 0.5 6 mm-LG FLAT HD | 6 |

3. Dress W3 between the main deck standoff and the side frame. See [Figure 3-32 on page 213](#).
4. Attach the A1 Front Frame assembly, following the A18 CRT assembly instructions as described in steps 1 through 16 under "Procedure 2B. A1 Front Frame/A18 CRT (8560E)."
5. Place LED A1W1DS1 into the line switch assembly.
6. Attach the line switch assembly into the front frame using the captive panhead screw. Ensure the connection of the line switch grounding lug to the screw.

Figure 3-34 Side Frame Mounting Screws

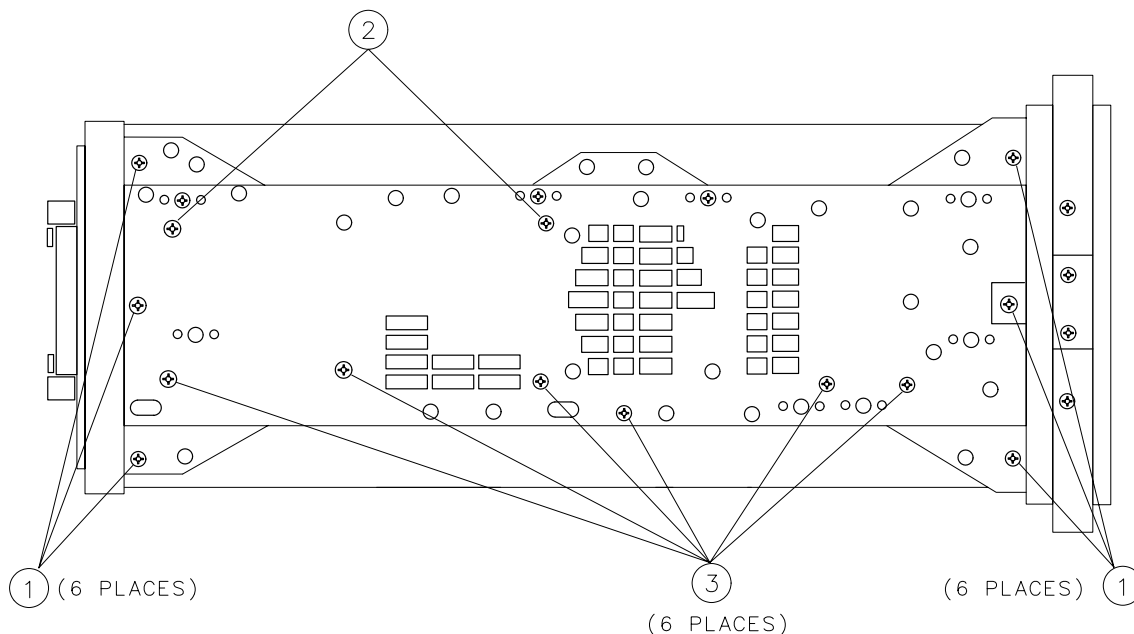

sm113e

7. On the top side of the spectrum analyzer, redress W3.
8. Connect W3 to A6J2. Dress W3 into the slotted opening in the deck.
9. Connect A1A1W1 to A3J602.
10. Secure the power supply cover shield to the power supply using three flathead screws. One end of the cover fits into a slot provided in the rear frame assembly. Ensure that the extended portion of the cover shield is seated in the shield wall groove. See [Figure 3-30 on page 209](#).
11. Place W3 and the other cable assemblies between the CRT assembly and the power supply cover so the W9 wires are underneath the surface of the power supply cover.
12. Fold up the A2, A3, A4, and A5 assemblies into the spectrum analyzer as described in steps 5 through 10 under "Procedure 5. A2, A3, A4, and A5 Assemblies Replacement."
13. Fold up A14 and A15 assemblies as described in steps 3 through 5 under "Procedure 9. A14 and A15 Assemblies Replacement."
14. Replace the spectrum analyzer cover assembly.

15. Connect the line-power cord and switch the spectrum analyzer power on. If the spectrum analyzer does not operate properly, turn off the spectrum analyzer power, disconnect the line cord, and recheck the spectrum analyzer.

Procedure 15. EEROM (A2U501 or A2U500)

Removal/Replacement

CAUTION The EEROM is replaced with the power on. Use a nonmetallic tool to remove the defective EEROM and install the new EEROM.

NOTE In newer spectrum analyzers, the EEPROM reference designator is U500. In older spectrum analyzers, the EEROM reference designator is U501.

1. Turn the HP 8560E/EC **LINE** switch off. Remove the spectrum analyzer cover assembly and fold out the A2, A3, A4, and A5 assemblies as described in steps 3 through 5 under "Procedure 5. A2, A3, A4, and A5 Assemblies Removal."
2. Turn the HP 8560E/EC **LINE** switch on.
3. Set the WR PROT/WR ENA jumper on the A2 Controller Assembly to the WR ENA position.
4. Press **CAL, MORE 1 OF 2, SERVICE CAL DATA, COPY EEROM**. The spectrum analyzer will store the contents of the EEROM into the program RAM.
5. Using a nonmetallic tool, carefully remove the defective EEROM.
6. Carefully install a new EEROM.
7. Press **COPY TO EEROM**. The spectrum analyzer will store the contents of the program RAM into the new EEROM.
8. Turn the HP 8560E/EC **LINE** switch off, then on, cycling the spectrum analyzer power. Allow the power-on sequence to finish.
9. If error message 701, 702, or 703 is displayed, press **RECALL, MORE,** and **RECALL ERRORS**. Use the STEP keys to view any other errors.
10. If error message 701 or 703 is displayed, perform Adjustment 9, "Frequency Response Adjustment" in Chapter 2. (If a TAM is available, perform the "Low Band Flatness" adjustment. Press **MODULE, ADJUST** to enter the adjust menu of the TAM.)
11. If there are no errors after cycling the spectrum analyzer power, the EEROM is working properly, but the frequency response correction data might be invalid. Check the spectrum analyzer frequency response.
12. Place the WR PROT/WR ENA jumper in the WR PROT position.
13. Fold the A2 and A3 assemblies into the spectrum analyzer as

described in "Procedure 5. A2, A3, A4, and A5 Assemblies." Secure the spectrum analyzer cover assembly.

Procedure 16. A21 OCXO (Non-Option 103)

Removal

1. Remove the rear frame assembly as described in steps 1 through 22 under "Procedure 13. Rear Frame/Rear Dress Panel Removal," steps 1 through 22.
2. Place the spectrum analyzer on its right side frame.
3. Fold out the A14 and A15 assemblies as described in steps 3 and 4 under "Procedure 9. A14 and A15 Assemblies Removal."
4. Remove the three screws (1) and three shoulder washers securing the OCXO to the main deck. See [Figure 3-35 on page 222](#).
5. Disconnect W49, coax 82, from the OCXO and disconnect W50 (orange cable) from the A15 RF assembly. Clip the tie wraps that hold W49 and W50 together and remove the OCXO and insulator from the spectrum analyzer (leaving the orange cable connected).

Figure 3-35 **A21 OCXO Mounting Screws**

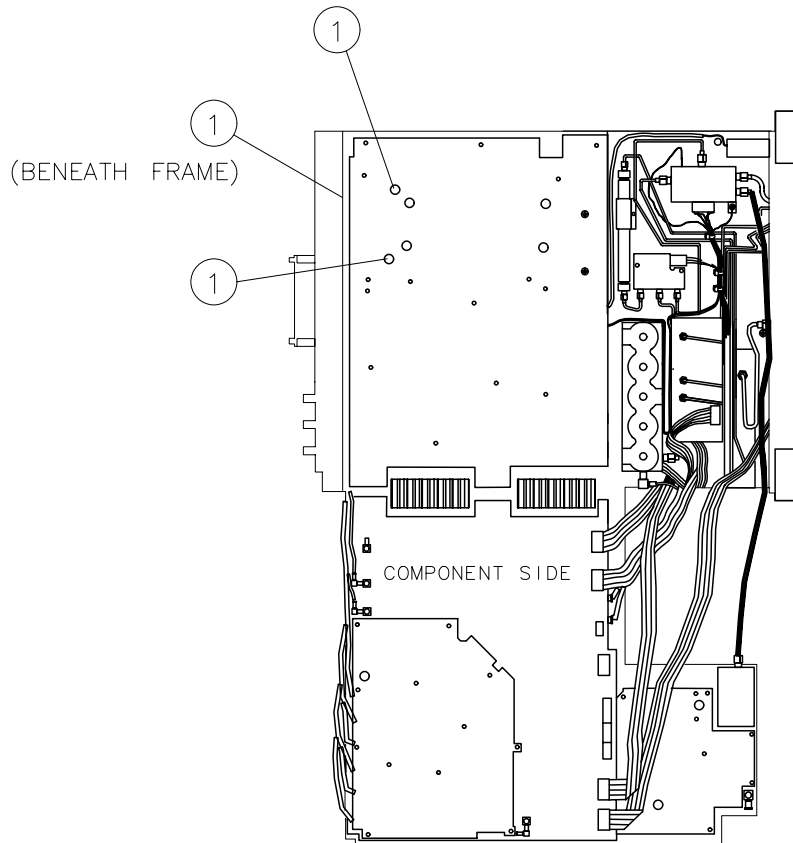

Replacement

1. Connect W49, coax 82, to the OCXO and position the OCXO and insulator in the spectrum analyzer. Dress W50 (orange cable) next to W49 through the opening in the deck.
2. Secure the OCXO to the spectrum analyzer main deck using three screws (1) and three shoulder washers. See [Figure 3-35 on page 222](#).
3. Fold the A14 and A15 assemblies into the spectrum analyzer as described in procedure 9.
4. Perform the rear frame assembly replacement procedure described in procedure 13.

4 **Replaceable Parts**

Introduction

This chapter contains information on ordering all replaceable parts and assemblies. Locate the instrument parts in the following figures and tables:

Table 4-1 on page 227. Reference Designations
Table 4-2 on page 228. Abbreviations
Table 4-3 on page 232. Multiples
Table 4-4 on page 233. Replaceable Parts

Table 4-5 on page 241. Parts List, Assembly Mounting
Table 4-6 on page 242. Parts List, Cover Assembly
Table 4-7 on page 242. Parts List, Main Chassis (8560EC)
Table 4-8 on page 243. Parts List, Main Chassis (8560E)
Table 4-9 on page 245. Parts List, RF Section
Table 4-10 on page 245. Parts List, Front Frame (8560EC)
Table 4-11 on page 246. Parts List, Front Frame (8560E)
Table 4-12 on page 247. Parts List, Rear Frame (8560EC)
Table 4-13 on page 248. Parts List, Rear Frame (8560E)

Figure 4-1 on page 241. Parts Identification, Assembly Mounting
Figure 4-2 on page 249. Parts Identification, Cover Assembly
Figure 4-3 on page 251. Parts Identification, Main Chassis (8560E)
Figure 4-4 on page 253. Parts Identification, RF Section
Figure 4-5 on page 255. Parts Identification, Front Frame (8560E)
Figure 4-5 on page 257. Parts Identification, Front Frame (8560E)
Figure 4-6 on page 259. Parts Identification, Rear Frame (8560E)
Figure 4-7 on page 261. Parts Identification, Main Chassis (8560EC)
Figure 4-8 on page 263. Parts Identification, Front Frame (8560EC)
Figure 4-9 on page 265. Parts Identification, Rear Frame (8560EC)

Ordering Information

To order a part or assembly, quote the Hewlett-Packard part number, indicate the quantity required, and address the order to the nearest HP Sales and Service office.

To order a part that is not listed in the replaceable parts table, include the instrument model number, the description and function of the part, and the number of parts required. Address the order to the nearest HP Sales and Service office.

Direct Mail-Order System

Within the USA, Hewlett-Packard can supply parts through a direct mail-order system. Advantages of using the system are as follows:

- Direct ordering and shipment from the HP Support Materials Organization in Roseville, California.
- No maximum or minimum on any mail order. (There is a minimum order amount for parts ordered through a local HP Sales and Service office when the orders require billing and invoicing.)
- Prepaid transportation. (There is a small handling charge for each order.)
- No invoices.

To provide these advantages, a check or money order must accompany each order. Mail-order forms and specific ordering information is available through your local Hewlett-Packard Sales and Service office. See [Table 1-6 on page 47](#).

Direct Phone-Order System

Within the USA, a phone order system is available for regular and hotline replacement parts service. A toll-free phone number is available, and Mastercard and Visa are accepted.

Regular Orders: The toll-free phone number, (800) 227-8164, is available 6 am to 5 pm, Pacific standard time, Monday through Friday. Regular orders have a four-day delivery time.

Hotline Orders: Hotline service for ordering emergency parts is available 24 hours a day, 365 days a year. There is an additional hotline charge to cover the cost of freight and special handling.

The toll-free phone number is (800) 227-8164, is available 6 am to 5 pm, Pacific standard time, Monday through Friday and (916) 785-8HOT for after hours, weekends, and holidays. Hotline orders are normally delivered the following business day.

Parts List Format

The following information is listed for each part:

1. The Hewlett-Packard part number.
2. The total quantity (Qty) in the assembly. This quantity is given only once, at the first appearance of the part in the list.
3. The description of the part.
4. A five-digit code indicating a typical manufacturer of the part.
5. The manufacturer part number.

Firmware-Dependent Part Numbers

Refer to the following firmware note, part number 5961-6734:

HP 8560 Series, HP 85620A, and HP 85629B Firmware Note.

Table 4-1 Reference Designations

| REFERENCE DESIGNATIONS | | | | | |
|------------------------|--|----|---|----|---|
| A | Assembly | F | Fuse | RT | Thermistor |
| AT | Attenuator, Isolator, Limiter, Termination | FL | Filter | S | Switch |
| | | HY | Circulator | T | Transformer |
| B | Fan, Motor | J | Electrical Connector (Stationary Portion), Jack | TB | Terminal Board |
| BT | Battery | | | TC | Thermocouple |
| C | Capacitor | | | TP | Test Point |
| CP | Coupler | K | Relay | U | Integrated Circuit, Microcircuit |
| CR | Diode, Diode Thyristor, Step Recovery Diode, Varactor | L | Coil, Inductor | | |
| | | M | Meter | VR | Breakdown Diode (Zener), Voltage Regulator |
| | | MP | Miscellaneous Mechanical Part | | |
| DC | Directional Coupler | P | Electrical Connector (Movable Portion), Plug | W | Cable, Wire, Jumper |
| DL | Delay Line | | | X | Socket |
| DS | Annunciator, Lamp, Light Emitting Diode (LED), Signaling Device (Visible) | | | Q | Silicon Controlled Rectifier (SCR), Transistor, Triode Thyristor |
| | | E | Miscellaneous Electrical Part | R | Resistor |

Table 4-2 Abbreviations

| ABBREVIATIONS | | | | | |
|---------------|------------------------|-------|--------------------|--------|----------------------|
| | A | | C | CONT | Contact, |
| | | | | | Continuous, |
| A | Across Flats, Acrylic, | C | Capacitance, | | Control, |
| | Air (Dry Method), | | Capacitor, | | Controller |
| | Ampere | | Center Tapped, | CONV | Converter |
| ADJ | Adjust, Adjustment | | Cermet, Cold, | CPRSN | Compression |
| ANSI | American National | | Compression | CUP-PT | Cup Point |
| | Standards Institute | CCP | Carbon Composition | CW | Clockwise, |
| | (formerly | | Plastic | | Continuous Wave |
| | USASI-ASA) | CD | Cadmium, Card, | | D |
| ASSY | Assembly | | Cord | | |
| AWG | American Wire Gage | CER | Ceramic | D | Deep, Depletion, |
| | | CHAM | Chamfer | | Depth, Diameter, |
| | B | CHAR | Character, | | Direct Current |
| BCD | Binary Coded | | Characteristic, | DA | Darlington |
| | Decimal | | Charcoal | DAP-GL | Diallyl Phthalate |
| BD | Board, Bundle | CMOS | Complementary | | Glass |
| BE-CU | Beryllium Copper | | Metal Oxide | DBL | Double |
| BNC | Type of Connector | | Semiconductor | DCDR | Decoder |
| BRG | Bearing, Boring | CNDCT | Conducting, | DEG | Degree |
| BRS | Brass | | Conductive, | D-HOLE | D-Shaped Hole |
| BSC | Basic | | Conductivity, | DIA | Diameter |
| BTN | Button | | Conductor | DIP | Dual In-Line Package |

Table 4-2

Abbreviations

| | | | | | |
|----------|--------------------------|---------|------------------------|----------|---------------------------------------|
| | D | FDTHRU | Feedthrough | HEX | Hexadecimal, Hexagon, |
| DIP-SLDR | Dip Solder | FEM | Female | | Hexagonal |
| D-MODE | Depletion Mode | FIL-HD | Fillister Head | | Hexagonal |
| DO | Package Type | FL | Flash, Flat, Fluid | HLCL | Helical |
| | Designation | FLAT-PT | Flat Point | HP | Hewlett-Packard |
| DP | Deep, Depth, Dia- | FR | Front | | Company, High Pass |
| | metric Pitch, Dip | FREQ | Frequency | | I |
| DP3T | Double Pole Three | FT | Current Gain | IC | Collector Current, Integrated Circuit |
| | Throw | | Bandwidth Product | ID | Identification, Inside Diameter |
| DWL | Dowell | | (Transition | IN | Inch |
| | E | | Frequency), Feet, Foot | INT | Integral, Intensity, Internal |
| E-R | E-Ring | FXD | Fixed | | J |
| EXT | Extended, Extension, | | | JFET | Junction Field |
| | External, Extinguish | | G | | Effect Transistor |
| | F | GEN | General, Generator | | K |
| F | Fahrenheit, Farad, | GND | Ground | K | Kelvin, Key, Kilo, Potassium |
| | Female, Film (Resistor), | GP | General Purpose, | KNRLD | Knurled |
| | Fixed, | | Group | KVDC | Kilovolts-Direct Current |
| | Flange, Frequency | | H | L | |
| FC | Carbon Film/ | | | LED | Light Emitting |
| | Composition, Edge | H | Henry, High | | Diode |
| | of Cutoff Frequency, | HDW | Hardware | LG | Length, Long |
| | Face | HEX | Hexadecimal, | LIN | Linear, Linearity |

Table 4-2 Abbreviations

| | L | | N | PC | Printed Circuit |
|-------|------------------------|------------|-----------------------------|------------|-------------------------|
| LK | Link, Lock | N | Nano, None | PCB | Printed Circuit |
| LKG | Leakage, Locking | N-CHA N | N-Channel | | Board |
| LUM | Luminous | NH | Nanohenry | P-CHA N | P-Channel |
| | | NM | Nanometer, | PD | Pad, Power |
| | M | | Nonmetallic | | Dissipation |
| M | Male, Maximum, | NO | Normally Open, Number | PF | Picofarad, Power Factor |
| | Mega, Mil, Milli, Mode | NOM | Nominal | PKG | Package |
| MA | Milliampere | NPN | Negative Positive | | |
| MACH | Machined | | Negative (Transistor) | PLSTC | Plastic |
| MAX | Maximum | NS | Nanosecond, | PNL | Panel |
| MC | Molded Carbon | | Non-Shorting, Nose | PNP | Positive Negative |
| MET | Metal, Metallized | NUM | Numeric | | Positive (Transistor) |
| MHz | Megahertz | NYL | Nylon (Polyamide) | POLYC | Polycarbonate |
| MINTR | Miniature | | O | POLYE | Polyester |
| MIT | Miter | | | POT | Potentiometer |
| MLD | Mold, Molded | OA | Over-All | POZI | Pozidriv Recess |
| MM | Magnetized Material, | OD | Outside Diameter | PREC | Precision |
| | Millimeter | OP AMP | Operational | PRP | Purple, Purpose |
| MOM | Momentary | | Amplifier | PSTN | Piston |
| MTG | Mounting | OPT | Optical, Option, | PT | Part, Point, |
| MTLC | Metallic | | Optional | | Pulse Time |
| SMA | Subminiature | | P | PW | Pulse Width |
| MW | Milliwatt | PA | Picoampere, Power Amplifier | PF | Picofarad, Power |
| | | | | | Q |
| | | PAN-HD | Pan Head | Q | Figure of Merit |

Table 4-2 Abbreviations

| | R | SPCG | Spacing | | U |
|------|--|-------|------------------------------|--------|------------------------------------|
| R | Range, Red, | SPDT | Single Pole | UCD | Microcandela |
| | Resistance, Resistor | SPST | Single Pole, Single Throw | UF | Microfarad |
| | Right, Ring | SQ | Square | UH | Microhenry |
| REF | Reference | SST | Stainless Steel | UL | Microliter, |
| RES | Resistance, Resistor | STL | Steel | | Underwriters Laboratories, Inc. |
| RF | Radio Frequency | | | UNHDND | Unhardened |
| RGD | Rigid | | T | | V |
| RND | Round | T | Teeth, | V | Variable, Violet, |
| RR | Rear | | Temperature, | | Volt, Voltage |
| | S | | Thickness, Time, | VAC | Vacuum, Volts— |
| SAWR | Surface Acoustic Wave Resonator | | Typical | | Alternating Current |
| SEG | Segment | PB | Lead (Metal), | VAR | Variable |
| SGL | Single | TA | Ambient | VDC | Volts—Direct Current |
| SI | Silicon, | | Temperature, | | W |
| | Square Inch | | Tantalum | W | Watt, Wattage, |
| SL | Slide, Slow | TC | Temperature Coefficient | | White, Wide, Width |
| SLT | Slot, Slotted | THD | Thread, Threaded | W/SW | With Switch |
| SMA | Type (Threaded Subminiature A-Connector) | THK | Thick | WW | Wire Wound |
| | | TO | Package Type | W | Watt, Wattage, |
| SMB | Subminiature | | Designation | | X |
| | B Type (Slip-on Connector) | TPG | Tapping | X | By (Used with |
| | | TR-HD | Truss Head | | Dimensions), |
| SMC | Subminiature | TRMR | Trimmer | | Reactance |
| SEG | Segment | TRN | Turn, Turns | | Y |
| | C-Type (Threaded | TRSN | Torsion | YIG | Yttrium-Iron- Garnet |
| SMB | Subminiature (Connector) | | | | Z |
| | | | | ZNR | Zener |

Table 4-3 Reference Designations, Abbreviations, and Multipliers (4 of 4)

| MULTIPLIERS | | | | | |
|--------------|--------|-----------|--------------|--------|------------|
| Abbreviation | Prefix | Multiple | Abbreviation | Prefix | Multiple |
| T | tera | 10^{12} | m | milli | 10^{-3} |
| G | giga | 10^9 | μ | micro | 10^{-6} |
| M | mega | 10^6 | n | nano | 10^{-9} |
| k | kilo | 10^3 | p | pico | 10^{-12} |
| da | deka | 10 | f | femto | 10^{-15} |
| d | deci | 10^{-1} | a | atto | 10^{-18} |
| c | centi | 10^{-2} | | | |

Manufacturers Code List

Refer to the Manufacturers Code List in the *HP 8560 E-Series Spectrum Analyzer Component Level Information*.

Table 4-4 Replaceable Parts

| Reference Designator | HP Part Number | Qty | Description | Mfr Code | Mfr Part Number |
|----------------------|----------------|-----|--|----------|-----------------|
| | | | ACCESSORIES SUPPLIED | | |
| | 1810-0118 | 1 | TERMINATION-COAXIAL SMA; 0.5W; 50Ω | 16179 | 2003-6113-02 |
| | 1250-0780 | 1 | ADAPTER-COAX F-BNC M-N | 24931 | 29JP104-2 |
| | HP 10502A | 1 | 50Ω COAX CABLE WITH BNC MALE | 28480 | HP 10502A |
| | 8710-1755 | 3 | WRENCH-HEX KEY | 55719 | AWML4 |
| | | | OPTION 908 | | |
| | 5062-0800 | 1 | RACK KIT WITH FLANGES (Includes Parts Listed Below) | | |
| | 5001-8739 | 2 | PANEL-DRESS | 28480 | 5001-8739 |
| | 5001-8740 | 2 | PANEL-SUB | 28480 | 5001-8740 |
| | 5001-8742 | 2 | SUPPORT-REAR | 28480 | 5001-8742 |
| | 5021-5807 | 2 | FRAME-FRONT | 28480 | 5021-5807 |
| | 5021-5808 | 2 | FRAME-REAR | 28480 | 5021-5808 |
| | 5021-5836 | 5 | CORNER-STRUT | 28480 | 5021-5836 |
| | 0510-1148 | 10 | RETAINER-PUSH-ON KB-TO-SHFT EXT | 11591 | 669 |
| | 0515-0886 | 16 | SCREW-MACH M3 × 0.5 6MM-LG PAN-HD | 28480 | 0515-0886 |
| | 0515-0887 | 8 | SCREW-MACH M3.5 × 0.6 6MM-LG PAN-HD | 28480 | 0515-0887 |
| | 0515-0889 | 12 | SCREW-MACH M3.5 × 0.6 6MM-LG | 28480 | 0515-0889 |
| | 0515-1241 | 8 | SCREW-MACH M5 × 0.8 12 MM-LG PAN-HD | 28480 | 0515-1241 |
| | 0515-1331 | 22 | SCREW-METRIC SPECIALTY M4 × 0.7 THD; 7MM | 28480 | 0515-1331 |
| | 5061-9679 | 2 | MOUNT FLANGE | 28480 | 5061-9679 |
| | 0515-1114 | 6 | SCREW-MACH M4 × 0.7 10MM-LG PAN-HD | 28480 | 0515-1114 |
| | 8710-1755 | | WRENCH-HEX KEY | 55719 | AWML4 |
| | 5958-6573 | 2 | ASSEMBLY INSTRUCTIONS | 28480 | 5958-6573 |
| | | | OPTION 909 | | |
| | 5062-1900 | 1 | RACK KIT WITH FLANGES AND HANDLES (Includes Parts Listed Below) | | |
| | 5001-8739 | | PANEL-DRESS | 28480 | 5001-8739 |
| | 5001-8740 | | PANEL-SUB | 28480 | 5001-8740 |
| | 5001-8742 | | SUPPORT-REAR | 28480 | 5001-8742 |
| | 5021-5807 | | FRAME-FRONT | 28480 | 5021-5807 |
| | 5021-5808 | | FRAME-REAR | 28480 | 5021-5808 |
| | 5021-5836 | | CORNER-STRUT | 28480 | 5021-5836 |
| | 0510-1148 | | RETAINER- PUSH-ON KB-TO-SHFT EXT | 11591 | 669 |
| | 0515-0886 | | SCREW-MACH M3 × 0.5 6MM-LG PAN-HD | 28480 | 0515-0886 |
| | 0515-0887 | | SCREW-MACH M3.5 × 0.6 6MM-LG PAN-HD | 28480 | 0515-0887 |
| | 0515-0889 | | SCREW-MACH M3.5 × 0.6 6MM-LG | 28480 | 0515-0889 |
| | 0515-1241 | | SCREW-MACH M5 × 0.8 12MM-LG PAN-HD | 28480 | 0515-1241 |
| | 0515-1331 | | SCREW-METRIC SPECIALTY M4 × 0.7 THD; 7MM | 28480 | 0515-1331 |
| | 5061-9501 | 2 | FRONT HANDLE ASS'Y | 28480 | 5061-9501 |
| | 5061-9685 | 2 | MOUNT FLANGE | 28480 | 5061-9685 |

Table 4-4 Replaceable Parts

| Reference Designator | HP Part Number | Qty | Description | Mfr Code | Mfr Part Number |
|--|-------------------------|-----|--|----------|-----------------|
| A1 | 0515-1106 | 6 | SCREW-MACH M4 × 0.7 16MM-LG PAN-HD | 28480 | 0515-1106 |
| | 8710-1755 | | WRENCH-HEX KEY | 55719 | AWML4 |
| | 5958-6573 | | ASSEMBLY INSTRUCTIONS | 28480 | 5958-6573 |
| | RACK SLIDE KIT | | | | |
| | 1494-0060 | 1 | SLIDE-CHAS 25-IN-LG 21.84-IN-TRVL (Includes Parts Listed Below. Slides cannot be ordered separately.) | 01561 | C858-2 |
| | 0515-0949 | 4 | SCREW-MACH M5 × 0.8 14MM-LG PAN-HD | 28480 | 0515-0949 |
| | 0515-1013 | 9 | SCREW-MACH M4 × 0.7 12MM-LG | 28480 | 0515-1013 |
| | 0515-0909 | 4 | SCREW-MACH M4 × 0.7 12MM-LG PAN-HD | 28480 | 0515-0909 |
| | 0535-0080 | 8 | NUT-CHANNEL M4 × 0.7 3.5MM-THK 10.3MM-WD | 28480 | 0535-0080 |
| | MAJOR ASSEMBLIES | | | | |
| FRONT FRAME ASSEMBLY (not available as a field replacement) | | | | | |
| (The A1 assembly includes the front frame, front faceplate, front panel keys, and other hardware. Refer to Figures 4-5 and 4-8 for individual part numbers.) | | | | | |
| A1A1 (8560EC) | 08563-60162 | 1 | BD AY-KEYBOARD | 28480 | 08563-60162 |
| A1A1(8560E) | 08562-60140 | 1 | BD AY-KEYBOARD | 28480 | 08562-60140 |
| A1A1W1 | 5062-8259 | 1 | CABLE ASSEMBLY, RIBBON, KEYBOARD (A1A1J1 to A3J602) | 28480 | 5062-8259 |
| A1A2 | 0960-0745 | 1 | RPG ASSEMBLY (Includes Cable) | 28480 | 0960-0745 |
| A1A2 | 0960-0745 | 1 | RPG ASSEMBLY (Includes Cable) | 28480 | 0960-0745 |
| A1W1 | 8120-8153 | 1 | CABLE ASSEMBLY PROBE POWER/LED | 28480 | 8120-8153 |
| A2 (8560EC) | 08563-60160 | 1 | CONTROLLER ASSEMBLY | 28480 | 08563-60160 |
| A2 (8560E) | 08563-60032 | 1 | CONTROLLER ASSEMBLY* | 28480 | 08563-60032 |
| A3 | 08563-60021 | 1 | INTERFACE ASSEMBLY | 28480 | 08563-60021 |
| A3 | 08563-60033 | 1 | INTERFACE ASSEMBLY (Option 007) | 28480 | 08563-60033 |
| A4 | 08563-60050 | 1 | LOG AMPLIFIER/CAL OSC. ASSY. | 28480 | 08563-60050 |
| A5 | 08563-60023 | 1 | IF FILTER ASSEMBLY | 28480 | 08563-60023 |
| A6 | 08563-60020 | 1 | POWER SUPPLY ASSEMBLY* (Does not include A6A1) | 28480 | 08563-60020 |
| A6A1 | 5062-7089 | 1 | HIGH VOLTAGE ASSEMBLY | 28480 | 5062-7089 |
| A7 | 5086-7744 | 1 | FIRST LO DISTRIBUTION AMPL | 28480 | 5086-7744 |
| A8 | 5086-7748 | 1 | LOW BAND MIXER | 28480 | 5086-7748 |
| (serial prefix | <3632A) | | | | |
| A8 | 5086-7982 | 1 | LOW BAND MIXER | 28480 | 5086-7982 |
| (serial prefix | ≥3632A) | | | | |

* These board assemblies are part of the rebuilt board exchange program. To order a rebuilt board, use the same number as that of the new board with the exception of the 7th digit which should be a 9. Example: New board number is 08562-60094.

Table 4-4 Replaceable Parts

| Reference Designator | HP Part Number | Qty | Description | Mfr Code | Mfr Part Number |
|--|----------------|-----|---|----------|-----------------|
| Therefore, the rebuilt board number will be 08562-69094. | | | | | |
| MAJOR ASSEMBLIES (Cont.) | | | | | |
| A9 | 5086-7822 | 1 | PORT ATTEN, 22 GHz | 28480 | 5086-7822 |
| | 5086-6822 | 1 | REBUILT A9, EXCHANGE REQUIRED | 28480 | 5086-6822 |
| A10 | 5086-7879 | 1 | BUILT-IN TRACKING GENERATOR | 28480 | 5086-7879 |
| | 5086-6879 | | REBUILT A10, EXCHANGE REQUIRED | 28480 | 5086-6879 |
| A11 | 5086-7906 | 1 | PORTABLE LVLVD YTO | 28480 | 5086-7906 |
| A13 | 5086-7812 | 1 | SECOND CONVERTER | 28480 | 5086-7812 |
| A14 | 08560-60059 | 1 | FREQUENCY CONTROL ASSEMBLY | 28480 | 08560-60059 |
| A15 | 08563-60043 | 1 | Option 103, without SIG ID | 28480 | 08563-60043 |
| A15 | 08563-60044 | 1 | Non-Option 103, without SIG ID | 28480 | 08563-60044 |
| A15 | 08563-60045 | 1 | Option 103, with SIG ID | 28480 | 08563-60045 |
| A15 | 08563-60046 | 1 | Non-Option 103, without SIG ID | 28480 | 08563-60046 |
| A15U100 | 5086-7806 | 1 | SAMPLER | 28480 | 5086-7806 |
| A16 | 08563-60030 | 1 | FAST ADC ASSEMBLY (Option 007) | 28480 | 08563-60030 |
| A17 (8560EC) | 08562-60166 | 1 | LCD DRIVER | 28480 | 08562-60166 |
| A17A1 (8560EC) | 0950-3644 | 1 | LCD INVERTER BOARD | 28480 | 0950-3644 |
| A17 (8560E) | 08563-60101 | 1 | CRT ASSEMBLY | 28480 | 08563-60101 |
| A18 (8560EC) | 08563-60170 | 1 | LCD ASSEMBLY-Includes LCD, LCD MOUNT, LCD GLASS, and two BACKLIGHTS | 28480 | 08563-60170 |
| A18DS1 and A18DS2 | 2090-0380 | 1 | Replaceable LCD Backlight Cartridge (part of LCD ASSEMBLY) | 28480 | 2090-0380 |
| A18 (8560E) | | 1 | CRT ASSEMBLY (Order by Individual Parts) | | |
| A18MP (8560E) | 5062-7095 | 1 | CRT WIRING ASSEM. (Includes Shield A18L1, and A18W1) | 28480 | 5062-7095 |
| A18MP2 (8560E) | 5041-3987 | 1 | SPACER, CRT | 28480 | 5041-3987 |
| A18V1 (8560E) | 2090-0225 | 1 | TUBE, CRT 6.7 IN | 28480 | 2090-0225 |
| A18W1 (8560E) | | | CABLE ASSEMBLY, TWO WIRE, TRACE ALIGN (P/O A18MP1, A17J5 to A18L1) | | |
| A19 | 08562-60042 | 1 | HP-IB ASSEMBLY | 28480 | 08562-60042 |
| A19W1 | 5061-9031 | 1 | CABLE ASSEMBLY, RIBBON, HP-IB (A2J5 to Rear Panel J2) | 28480 | 5061-9031 |
| A20 | 5062-7755 | 1 | BATTERY ASSY (Includes W6) | 28480 | 5062-7755 |
| A21 [†] | 5063-0245 | 1 | OCXO CABLE ASSEMBLY, 10.0 MHz | 28480 | 5063-0245 |
| B1 | 5061-9036 | 1 | FAN ASSEMBLY (Includes Wire) | 28480 | 5083-9036 |
| BT1 | 1420-0341 | 1 | BATTERY 3.0 V 1.2 A-HR LITHIUM POLYCARBON MONOFLORIDE | 08709 | BR 213 A 55P |
| F1 | 2110-0709 | 1 | THIONYL FUSE 5A 250V NTD FE IEC (230 VAC Operation) | 16428 | GDA-5 |

Table 4-4 Replaceable Parts

| Reference Designator | HP Part Number | Qty | Description | Mfr Code | Mfr Part Number |
|---|----------------|-----|--|----------|-----------------|
| †Not present in Option 103. | | | | | |
| F1 | 2110-0756 | 1 | FUSE 5A 125V NTD UL (115 VAC Operation) | 28480 | 2110-0756 |
| FL1 | 0955-0703 | 1 | LOW PASS FILTER, 2.9 GHz | 28480 | 0955-0703 |
| FL2 | 0955-0519 | 1 | LOW PASS FILTER, 4.4 GHz | 28480 | 0955-0519 |
| FL3 | | | NOT ASSIGNED | | |
| LS1 | 9160-0282 | 1 | LOUDSPEAKER 2.5 IN SQ (Part of W5) | 28480 | 9160-0282 |
| CHASSIS MECHANICAL PARTS | | | | | |
| (See Figures 4-1 through 4-9 for a complete listing of mechanical chassis parts.) | | | | | |
| ASSEMBLY SHIELDS | | | | | |
| A3 Assembly | 5021-6723 | 1 | PEAK DETECTOR (TOP) | 28480 | 5021-6723 |
| | 5021-6724 | 1 | PEAK DETECTOR (BOTTOM) | 28480 | 5021-6724 |
| | 0515-2080 | 2 | SCREW M2.5 14L | 28480 | 0515-2080 |
| | 0515-1486 | 10 | SCREW M2.5 9.5L | 28480 | 0515-1486 |
| | 0905-0375 | 12 | O-RING .070ID | 28480 | 0905-0375 |
| A4 Assembly | 2190-0583 | 12 | WSHR LK M2.5ID | 28480 | 2190-0583 |
| | 5063-0222 | 1 | AMP 1 (BOTTOM) | 28480 | 5063-0222 |
| | 5063-0221 | 1 | AMP 1 (TOP) | 28480 | 5063-0221 |
| | 5063-0219 | 1 | AMP 2 (TOP) | 28480 | 5063-0219 |
| | 5063-0220 | 1 | AMP 2 (BOTTOM) | 28480 | 5063-0220 |
| | 0515-1486 | 4 | SCREW SMM 2.5 10 PNTROX | 28480 | 0515-1486 |
| | 0515-2080 | 23 | SCREW M2.5 14L | 28480 | 0515-2080 |
| A5 Assembly | 2190-0583 | 23 | WSHR LK M2.5ID | 28480 | 2190-0583 |
| | 0905-0375 | 23 | O-RING .070ID | 28480 | 0905-0375 |
| | 5021-6729 | 1 | IF 1 (TOP) | 28480 | 5021-6729 |
| | 5021-6730 | 1 | IF 1 (BOTTOM) | 28480 | 5021-6730 |
| | 5021-6731 | 1 | IF 2 (TOP) | 28480 | 5021-6731 |
| | 5021-6732 | 1 | IF 2 (BOTTOM) | 28480 | 5021-6732 |
| | 0515-2081 | 16 | SCREW 5MM 2.5 16 PNPDS | 28480 | 0515-2081 |
| A14 Assembly | 0905-0375 | 16 | O-RING .070ID | 28480 | 0905-0375 |
| | 2190-0583 | 16 | WSHR LK M2.5ID | 28480 | 2190-0583 |
| | 5063-0209 | 1 | FC (TOP) | 28480 | 5063-0209 |
| | 5063-0210 | 1 | FC (BOTTOM) | 28480 | 5063-0210 |
| | 0515-0951 | 13 | SCREW 5MM 2.5 16 PNPDS | 28480 | 0515-0951 |
| A15 Assembly | 0905-0375 | 13 | O-RING .070ID | 28480 | 0905-0375 |
| | 2190-0583 | 13 | WSHR LK M2.5ID | 28480 | 2190-0583 |
| | 5021-6735 | 1 | REF (TOP) | 28480 | 5021-6735 |
| | 5021-6736 | 1 | REF (BOTTOM) | 28480 | 5021-6736 |
| | 5022-0047 | 1 | SYNTHZR (TOP) | 28480 | 5022-0047 |

Table 4-4 Replaceable Parts

| Reference Designator | HP Part Number | Qty | Description | Mfr Code | Mfr Part Number |
|-------------------------|----------------|-----|--|----------|-----------------|
| | 5022-0046 | 1 | SYNTHZR (BOTTOM) | 28480 | 5022-0046 |
| | 5021-6739 | 1 | SIGPATH (TOP) | 28480 | 5021-6739 |
| | 5021-6740 | 1 | SIGPATH (BOTTOM) | 28480 | 5021-6740 |
| | 5002-0631 | 1 | BRACE, RF BD | 28480 | 5002-0631 |
| | 0515-2081 | 36 | SCREW 5MM 2.5 16 PNPDS | 28480 | 0515-2081 |
| | 0905-0375 | 36 | O-RING .070ID | 28480 | 0905-0375 |
| | 2190-0583 | 36 | WSHR LK M2.5 ID | 28480 | 2190-0583 |
| | 0515-0367 | 2 | SCREW 2.5M X 8MM LG TORX | 28480 | 0515-0367 |
| CABLE ASSEMBLIES | | | | | |
| W1 | 8120-5682 | 1 | POWER CABLE, RIBBON | 28480 | 8120-5682 |
| W2 | 5061-9025 | 1 | CONTROL CABLE, RIBBON | 28480 | 5061-9025 |
| W3 | 5062-0728 | 1 | CABLE ASSEMBLY LINE SWITCH | 28480 | 5062-0728 |
| W4 | 5061-9033 | 1 | CABLE ASSEMBLY, RIBBON, OPTION MODULE (A2J6 to Rear Panel J3) | 28480 | 5061-9033 |
| W5 | 5062-6471 | 1 | VOLUME CONTROL ASSEMBLY (Includes W55) | 28480 | 5062-6471 |
| W6 | 5062-0767 | 1 | CABLE ASSEMBLY, BATTERY (A2J9 to Rear Panel Battery Holder) | 28480 | 5062-0767 |
| W7 | 8120-5697 | 1 | CABLE ASSEMBLY, RIBBON (A2J3 to A17J1) | 28480 | 8120-5697 |
| W7 | 8120-6172 | 1 | CABLE ASSEMBLY, RIBBON (A2J3 to A17J1, A16J1 and A16J2) | 28480 | 8120-6172 |
| Option 007 | | | | | |
| W8 | 5061-9030 | 1 | CABLE ASSEMBLY, DISPLAY POWER (A6J4 to A17J2) | 28480 | 5061-9030 |
| W9 | 5062-6482 | 1 | CABLE ASSEMBLY, CRT, YOKE (A17J3 and J7 to A18V1) | 28480 | 5062-6482 |
| W10 | 5062-0742 | 1 | CABLE ASSEMBLY, RIBBON, A11 YTO DRIVE (A14J3 to A11J1) | 28480 | 5062-0742 |
| W11 | 08562-60064 | 1 | CABLE ASSEMBLY, RIBBON, A9 ATTEN. DRIVE (A14J6 to A9) | 28480 | 08562-60064 |
| W12 | 8120-5681 | 1 | CABLE ASSEMBLY, A7 LODA DRIVE (serial prefix <3632A) | 28480 | 08562-60064 |
| W12 | 08560-60081 | 1 | CABLE ASSEMBLY, A7 LODA AND A8 MIXER DRIVE (serial prefix ≥3632A) | 28480 | 08562-60064 |
| W13 | 5062-0743 | 1 | CABLE ASSEMBLY, RIBBON, A13 2ND CONV DRIVE (A14J12 to A13) (Part of Cable) Assembly-Microcircuit, 08562-60045) | 28480 | 5062-0743 |
| W14 | 08560-60002 | 1 | CABLE ASSEMBLY, RIBBON, A10 CONTROL SIGNAL (A14J13 to A10J1) | 28480 | 08560-60002 |
| W15 | | | NOT ASSIGNED | | |
| W16 | 08560-60001 | 1 | CABLE ASSEMBLY, A10 ALC EXT (Option 002) (Rear Panel J11 to A10) | 28480 | 08560-60001 |
| W18 | 5062-0721 | 1 | CABLE ASSEMBLY, COAX 97, LO SWEEP | 28480 | 5062-0721 |

Table 4-4 Replaceable Parts

| Reference Designator | HP Part Number | Qty | Description | Mfr Code | Mfr Part Number |
|----------------------|----------------|-----|--|----------|-----------------|
| | | | 0.5 V/GHz (A14J7 to Rear Panel J8) | | |
| | | | CABLE ASSEMBLIES (Cont.) | | |
| W19 | 5062-0723 | 1 | CABLE ASSEMBLY, COAX 83, OPT 001 2ND IF OUT (A15J803 to Rear Panel J10) | 28480 | 5062-0723 |
| W20 | 5062-0717 | 1 | CABLE ASSEMBLY, COAX 6, 0 SPAN VIDEO (A3J103 to A2J4) (Non-Option 007) | 28480 | 5062-0717 |
| W20 | 5063-0281 | 1 | CABLE ASSEMBLY, COAX 6, 0 SPAN VIDEO (A3J103 to A16J4) Option 007 | 28480 | 5063-0281 |
| W22 | 5062-0709 | 1 | CABLE ASSEMBLY, COAX 0, 10 MHz FREQ. COUNT (A15J302 to A2J8) (Rear Panel J5 to A3J600) | 28480 | 5062-0709 |
| W24* | 5062-0720 | 1 | CABLE ASSEMBLY, COAX, 5 VIDEO OUT (A3J102 to Rear Panel J4) | 28480 | 5062-0720 |
| W25 | 5062-0718 | 1 | CABLE ASSEMBLY, COAX 4, BLANKING OUT (A3J601 to Rear Panel J6) | 28480 | 5062-0718 |
| W27 | 5062-0714 | 1 | CABLE ASSEMBLY, FILTER 10.7 MHz (A5J5 to A4J3) | 28480 | 5062-0714 |
| W29 | 5062-0711 | 1 | CABLE ASSEMBLY, COAX 7, 10.7 IF (A15J601 to A5J3) | 28480 | 5062-0711 |
| W31 | 5062-0722 | 1 | CABLE ASSEMBLY, COAX 8, REF IN/OUT (A15J301 to Rear Panel J9) | 28480 | 5062-0722 |
| W32 | 5062-0705 | 1 | CABLE ASSEMBLY, COAX 87, SAMPLER IF (A15J101 to A14J501) | 28480 | 5062-0705 |
| W33 | 5062-0706 | 1 | CABLE ASSEMBLY, COAX 81, 2ND LO DRIVE (A15J701 to A13J4) | 28480 | 5062-0706 |
| W34 | 8120-5446 | 1 | CABLE ASSEMBLY, COAX 0, 1ST LO SAMP. (A7J4 to A15A2J1) | 28480 | 8120-5446 |
| W35 | 5062-0710 | 1 | CABLE ASSEMBLY, COAX 92, INT 2ND IF (A13J2 to A15J801) | 28480 | 5062-0710 |
| W36† | 5062-0725 | 1 | CABLE ASSEMBLY, COAX 86, EXT 2ND IF (Front Panel J3 to A15J802) | 28480 | 5062-0725 |
| W37 | 5062-0707 | 1 | CABLE ASSEMBLY, COAX 85, 10 MHz REF 1 (Front Panel J3 to A15J802) | 28480 | 5062-0707 |
| W38 | 08560-20005 | 1 | CABLE ASSEMBLY and SEMI-RIGID, 1st LO IN (A15J303 to A14J301) (A11J2 to A7J1) | 28480 | 08560-20002 |
| W39 | 08560-20068 | 1 | CABLE ASSEMBLY, SEMI-RIGID, 1ST MIXER OUT (A7J2 to A8J3) (serial prefix ≥3632A) | 28480 | 08560-20006 |
| W40 | 5062-0724 | 1 | CABLE ASSEMBLY, COAX 89, CAL OUT (A15J501 to Front Panel J5) | 28480 | 5062-0724 |
| W41 | 5021-8635 | 1 | CABLE ASSEMBLY, SEMI-RIGID, RF INPUT (Front panel J1 to A9J1) | 28480 | 5021-8635 |

Table 4-4 Replaceable Parts

| Reference Designator | HP Part Number | Qty | Description | Mfr Code | Mfr Part Number |
|---|----------------|-----|---|----------|-----------------|
| *Not present in Option 327. | | | | | |
| CABLE ASSEMBLIES (Cont.) | | | | | |
| W43 | 08560-20001 | 1 | CABLE ASSEMBLY, SEMI-RIGID, A10 LO IN (A10 to A7J3) (Option 002) | 28480 | 08560-20001 |
| W44 | 5022-1125 | 1 | CABLE ASSEMBLY, SEMI-RIGID (A9 to FL1J1) | 28480 | 5022-1125 |
| W45 | 5022-1123 | 1 | CABLE ASSEMBLY, SEMI-RIGID (FL1J2 to A8J1) (serial prefix <3632A) | 28480 | 5022-1123 |
| W45 | 5022-2826 | 1 | CABLE ASSEMBLY, SEMI-RIGID (FL1J2 to AT1) (serial prefix ≥3632A and <3804A) | 28480 | 5022-1123 |
| W46 | 08560-20002 | 1 | CABLE ASSEMBLY, SEMI-RIGID, A10 LO OUT (A10 to Front Panel J4) (Option 002) | 28480 | 08560-20002 |
| W47 | 08560-20003 | 1 | CABLE ASSEMBLY, SEMI-RIGID, A10 RF OUT (A10 to Front Panel J6) (Option 002) | 28480 | 08560-20003 |
| W48 | 08560-60003 | 1 | CABLE ASSEMBLY, COAX 80, A10 600 MHz (A15J702 to A10) Option 002 (A21 to A15J305) | 28480 | 08560-60003 |
| W50 [†] | 5063-0245 | 1 | CABLE ASSEMBLY, OCXO (A21 to A15J306) | 28480 | 5063-0245 |
| W51 | 5062-6478 | 1 | CABLE ASSEMBLY, COAX 84, 10 MHz REF2 (A15J304 to A4J7) | 28480 | 5062-6478 |
| W52 | 5062-6477 | 1 | CABLE ASSEMBLY, COAX 9, 10.7 MHz CAL SIG (A5J4 to A4J8) | 28480 | 5062-6477 |
| W53 | 5062-6476 | 1 | CABLE ASSEMBLY, COAX 1, FREQ COUNTER (A2J7 to A4J5) | 28480 | 5062-6476 |
| W54 | 5062-6475 | 1 | CABLE ASSEMBLY, COAX 2, VIDEO (A3J101 to A4J4) | 28480 | 5062-6475 |
| W55 | 5062-6471 | 1 | CABLE ASSEMBLY, AUDIO (A4J6 to LSI J1 and Rear Panel J1) | 28480 | 5062-6471 |
| W56 | 5022-0049 | 1 | CABLE ASSEMBLY, SEMI-RIGID (A8J2 to FL2J1) (serial prefix <3632A) | 28480 | 5022-0049 |
| W56 | 5022-2827 | 1 | CABLE ASSEMBLY, SEMI-RIGID (A8J2 to FL2J1) (serial prefix ≥3632A) | 28480 | 5022-0049 |
| W57 | 5022-0050 | 1 | CABLE ASSEMBLY, SEMI-RIGID (FL2J2 to A13J1) | 28480 | 5022-0050 |
| W58 | 5062-0722 | 1 | CABLE ASSEMBLY, COAX 8, ALT SWEEP OUT (A14J20 to Rear Panel J11) (Option 005) | 28480 | 5062-0722 |
| W59 | 5063-0282 | 1 | CABLE ASSEMBLY, COAX 839, FAST ADC CLOCK (A2J15 to A16J3) (Option 007) | 28480 | 5063-0282 |
| W60 | 8120-6919 | 1 | DISPLAY CABLE, RIBBON (A2J8 to A17J1) | 28480 | 8120-6919 |
| †Not present in Option 002 or Option 327. | | | | | |

Table 4-4 Replaceable Parts

| Reference Designator | HP Part Number | Qty | Description | Mfr Code | Mfr Part Number |
|-----------------------------|-----------------------|------------|--|-----------------|------------------------|
| ‡Not present in Option 103. | | | | | |
| W61 | 8120-5026 | 1 | CABLE, COAX (A2J9to A17J7) | 28480 | 8120-5026 |
| W62 | 8120-8482 | 1 | CABLE, RIBBON (A17J6 to A17A1) | 28480 | 8120-8482 |
| W63 | 8120-8409 | 1 | CABLE, RIBBON (A17J5 to A18) | 28480 | 8120-8409 |
| W64 | 8121-0062 | 1 | VGA CABLE ASSEMBLY (A17J4 to J1 on rear panel) | 28480 | 8121-0062 |

Figure 4-1 **Parts Identification, Assembly Mounting**

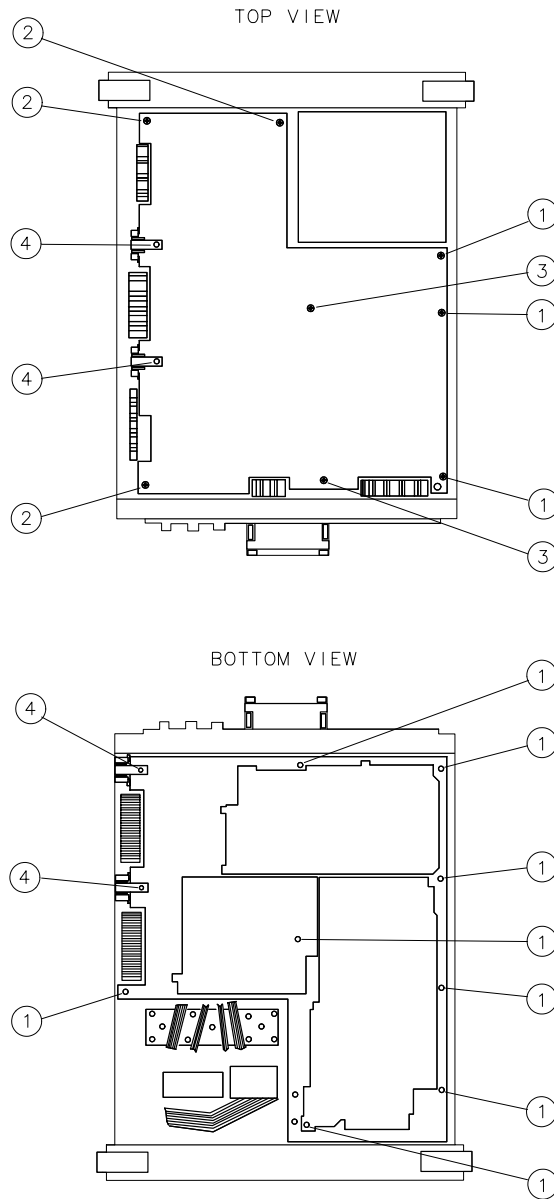

sp126e

Table 4-5 **Assembly Mounting (see Figure 4-1)**

| Item | HP Part Number | Qty | Description | Mfr Code | Mfr Part Number |
|------|----------------|-----|--------------------------------------|----------|-----------------|
| 1 | 0515-1349 | 11 | SCREW-MACH M3 X 30MM-LG PAN-HD TORX | 28480 | 0515-1349 |
| 2 | 0515-2310 | 3 | SCREW-MACH M3 X 60MM-LG PAN-HD TORX | 28480 | 0515-2310 |
| 3 | 0515-2308 | 2 | SCREW-MACH M3 X 100MM-LG PAN-HD TORX | 28480 | 0515-2308 |
| 4 | 0515-2332 | 10 | SCREW-MACH M3 X 6MM-LG PAN-HD TORX | 28480 | 0515-2332 |
| 4 | 0515-0664 | 2 | SCREW-MACH M3 X 12MM-LG PAN-HD TORX | 28480 | 0515-0664 |

Table 4-6 Parts List, Cover Assembly (See Figure 4-2) – 8560E and 8560EC

| Item | HP Part Number | Qty | Description | Mfr Code | Mfr Part Number |
|------|----------------|-----|---------------------------------------|----------|-----------------|
| 1 | 5041-8911 | 1 | BAIL HANDLE | 28480 | 5041-8911 |
| 2 | 5041-8912 | 2 | TRIM CAP | 28480 | 5041-8912 |
| 3 | 0515-1114 | 4 | SCREW MACH M4 X 10MM-LG PAN-HD | 28480 | 0515-1114 |
| 4 | 1460-2164 | 2 | SPRING-CPRSN .845 IN-OD 1.25-1N-OA-LG | 28480 | 1460-2164 |
| 5 | 5021-6343 | 2 | RING GEAR | 28480 | 5021-6343 |
| 6 | 5021-6344 | 2 | SOCKET GEAR | 28480 | 5021-6344 |
| 7 | 5021-8667 | 2 | HANDLE PLATE | 28480 | 5021-8667 |
| 8 | 5001-8728 | 2 | BACKUP PLATE | 28480 | 5001-8728 |
| 9 | 0515-1367 | 6 | SCREW MACH M4 X 8MM-LG 90DEG-FLH-HD | 28480 | 0515-1367 |
| 10 | 0515-1133 | 2 | SCREW-MACH M5 X 16MM-LG | 28480 | 0515-1133 |
| 11 | 5001-8800 | 1 | COVER | 28480 | 5001-8800 |
| 12 | 5041-7238 | 1 | MOISTURE DEFLECTOR-LF | 28480 | 5041-7238 |
| 13 | 5041-3989 | 1 | MOISTURE DEFLECTOR-RT | 28480 | 5041-3989 |
| 14 | 5041-8913 | 2 | SIDE TRIM | 28480 | 5041-8913 |
| 15 | 0515-1114 | 2 | SCREW-MACH M4 X 10MM-LG PAN-HD | 28480 | 0515-1114 |
| 16 | 5041-8907 | 2 | REAR FOOT | 28480 | 5041-8907 |
| 17 | 0900-0024 | 4 | O-RING .145-1N-XSECT-DIA SIL | 51633 | A5568-007 |
| 18 | 2190-0587 | 4 | WASHER-LK HLCL 5.0 MM 5.1-MM-ID | 28480 | 2190-0587 |
| 19 | 0515-1218 | 4 | SCREW-SKT-HD-CAP M5 X 40MM-LG | 28480 | 0515-1218 |
| 20 | 08562-80028 | 1 | INSULATOR 292 X 355 MM .51 THK | 28480 | 08562-80028 |

Table 4-7 Parts List, Main Chassis – 8560EC (see Figure 4-8)

| Item | HP Part Number | Qty | Description | Mfr Code | Mfr Part Number |
|------|----------------|-----|---|----------|-----------------|
| 1 | 0515-2145 | 4 | SCREW-MACH M3 X 8MM-LG PAN-HD TORX | 28480 | 0515-2145 |
| 4 | 0380-2052 | 2 | SPACER 0.937LG 0.166ID | 28480 | 0380-2052 |
| 5 | 5002-1010 | 1 | COVER, A6 POWER SUPPLY (Includes label) | 28480 | 5002-1010 |
| 6 | 0515-2309 | 3 | SCREW-MACH M3 X 0.5 45MM-LG TORX | 28480 | 0515-2309 |
| 7 | 5041-7246 | 1 | BOARD MOUNT | 28480 | 5041-7246 |
| 8 | 0515-0372 | 2 | SCREW-MACH M3 X 8MM-LG PAN-HD TORX | 28480 | 0515-0372 |
| 14 | 5002-1008 | 1 | MAIN DECK | 28480 | 5002-1008 |
| 15 | 5002-1002 | 1 | FRONT END DECK | 28480 | 5002-1002 |
| 16 | 0515-1101 | 4 | SCREW-MACH M4 X 8MM-LG FLH-HD TORX | 28480 | 0515-1101 |
| 17 | 0515-1227 | 2 | SCREW MACH M3 X 6MM-LG FLH-HD TORX | 28480 | 0515-1227 |
| 18 | 5021-7464 | 2 | SIDE FRAME | 28480 | 5021-7464 |
| 19 | 0515-1101 | 12 | SCREW-MACH M4 X 8MM-LG FLH-HD TORX | 28480 | 0515-1101 |
| 20 | 0515-1227 | 12 | SCREW MACH M3 X 6MM-LG FLH-HD TORX | 28480 | 0515-1227 |
| 21 | 0515-1227 | 8 | SCREW MACH M3 X 6MM-LG FLH-HD TORX | 28480 | 0515-1227 |
| 22 | 0515-1227 | 5 | SCREW MACH M3 X 6MM-LG FLH-HD TORX | 28480 | 0515-1227 |
| 23 | 5021-5484 | 5 | MOUNTING POST | 28480 | 5021-5484 |
| 24 | 5062-0750 | 2 | HINGE, 2 BOARD | 28480 | 5062-0750 |
| 25 | 5062-0751 | 2 | HINGE, 4 BOARD | 28480 | 5062-0751 |
| 26 | 5041-7250 | 1 | CABLE CLAMP | 28480 | 5041-7250 |

Table 4-7 Parts List, Main Chassis – 8560EC (see Figure 4-8)

| Item | HP Part Number | Qty | Description | Mfr Code | Mfr Part Number |
|-------|----------------|-----|---|----------|-----------------|
| 27 | 0515-2164 | 2 | SCREW-MACH M3 X 35MM-LG TORX | 28480 | 0515-2164 |
| 28 | 0515-1227 | 2 | SCREW-MACH M3 X 6MM-LG FLH-HD TORX | 28480 | 0515-1227 |
| 30 | 5063-0269 | 1 | SHIELD WALL, TOP | 28480 | 5063-0269 |
| 31 | 5063-0268 | 1 | SHIELD WALL, BOTTOM | 28480 | 5063-0268 |
| 32 | 0515-0382 | 2 | SCREW | 28480 | 0515-0382 |
| 33 | 0515-0430 | 2 | SCREW-INVERTER BOARD | 28480 | 0515-0430 |
| 34 | 0515-0372 | 4 | SCREW-DISPLAY DRIVER | 28480 | 0515-0372 |
| 35 | 0400-0333 | 4 | STANDOFF CUSHIONS | 28480 | 0400-0333 |
| 36 | 1000-1014 | 1 | LCD GLASS PLATE | 28480 | 1000-1014 |
| 37 | 5041-9632 | 1 | LCD MOUNT | 28480 | 5041-9632 |
| 38 | 5000-8314 | 1 | LCD BACKPLATE | 28480 | 5000-8314 |
| 39 | 5022-3667 | 1 | LCD DRIVER SHIELD | 28480 | 5022-3667 |
| A17 | 08562-6016 | 1 | LCD DRIVER BOARD | 28480 | 08562-6016 |
| A17A1 | 0950-60166 | 1 | INVERTER BOARD | 28480 | 0950-60166 |
| A18 | 2090-0379 | 1 | LCD ASSEMBLY- INCLUDES LCD GLASS, LCD MOUNT, AND A18DS1 and A18DS2 BACKLIGHT CABLES | 28480 | 2090-0379 |

Table 4-8 Parts List, Main Chassis (See Figure 4-3) – 8560E

| Item | HP Part Number | Qty | Description | Mfr Code | Mfr Part Number |
|------|----------------|-----|-------------------------------------|----------|-----------------|
| 1 | 0515-2145 | 4 | SCREW-MACH M3 X 8MM-LG PAN-HD TORX | 28480 | 0515-2145 |
| 3 | 0515-1715 | 3 | SCREW-MACH M3 X 35MM-LG PAN-HD TORX | 28480 | 0515-1715 |
| 4 | 0380-2052 | 2 | SPACER .937LG .166ID | 28480 | 0380-2052 |
| 5 | 5002-1010 | 1 | COVER, A6 POWER SUPPLY | 28480 | 5002-1010 |
| | 5181-8215 | 1 | WARNING LABEL (not shown) | 28480 | 5181-8215 |
| | 08562-80029 | 1 | INSULATOR 100 X 140 (not shown) | 28480 | 08562-80029 |
| 6 | 0515-2309 | 3 | SCREW-MACH M3 X 0.5 45MM-LG TORX | 28480 | 0515-2309 |
| 7 | 5041-7246 | 1 | BOARD CLIP | 28480 | 5041-7246 |
| 8 | 0515-0372 | 2 | SCREW-MACH M3 X 8MM-LG PAN-HD TORX | 28480 | 0515-0372 |
| 9 | 5041-8961 | 1 | TOP COVER, A17 | 28480 | 5041-8961 |
| | 5041-7248 | 1 | BOTTOM COVER, A17 | 28480 | 5041-7248 |
| 10 | 5021-5486 | 2 | CRT MOUNT | 28480 | 5021-5486 |
| 11 | 5001-5870 | 2 | CRT MOUNT STRAP | 28480 | 5001-5870 |
| 13 | 0515-0372 | 4 | SCREW-MACH M3 X 8MM-LG PAN-HD TORX | 28480 | 0515-0372 |
| 14 | 5002-1008 | 1 | MAIN DECK | 28480 | 5002-1008 |
| | 5002-1009 | 1 | EMI SHIELD (not shown) | 28480 | 5002-1009 |
| 15 | 5001-8755 | 1 | FRONT END DECK | 28480 | 5001-8755 |
| 16 | 0515-1101 | 4 | SCREW-MACH M4 X 8MM-LG FLH-HD TORX | 28480 | 0515-1101 |
| 17 | 0515-1227 | 2 | SCREW MACH M3 X 6MM-LG FLH-HD TORX | 28480 | 0515-1227 |
| 18 | 5021-7464 | 2 | SIDE FRAME | 28480 | 5021-7464 |
| 19 | 0515-1101 | 12 | SCREW-MACH M4 X 8MM-LG FLH-HD TORX | 28480 | 0515-1101 |
| 20 | 0515-1227 | 12 | SCREW MACH M3 X 6MM-LG FLH-HD TORX | 28480 | 0515-1227 |

Table 4-8 Parts List, Main Chassis (See Figure 4-3) – 8560E

| Item | HP Part Number | Qty | Description | Mfr Code | Mfr Part Number |
|-------------|-----------------------|------------|---|-----------------|------------------------|
| 21 | 0515-1227 | 8 | SCREW MACH M3 X 6MM-LG FLH-HD TORX | 28480 | 0515-1227 |
| 22 | 0515-1227 | 5 | SCREW MACH M3 X 6MM-LG FLH-HD TORX | 28480 | 0515-1227 |
| 23 | 5021-5484 | 5 | MOUNTING POST | 28480 | 5021-5484 |
| 24 | 5062-0750 | 2 | HINGE, 2 BOARD | 28480 | 5062-0750 |
| 25 | 5062-0751 | 2 | HINGE, 4 BOARD | 28480 | 5062-0751 |
| 26 | 5041-7250 | 1 | CABLE CLAMP | 28480 | 5041-7250 |
| 27 | 0515-2164 | 2 | SCREW-MACH M3 X 35MM-LG TORX | 28480 | 0515-2164 |
| 28 | 0515-1227 | 2 | SCREW-MACH M3 X 6MM-LG FLH-HD TORX | 28480 | 0515-1227 |
| 29 | 5181-8214 | 1 | LABEL, ASSEMBLY LOCATIONS | 28480 | 5181-8214 |
| 30 | 5063-0269 | 1 | SHIELD WALL, TOP | 28480 | 5063-0269 |
| 31 | 5063-0268 | 1 | SHIELD WALL, BOTTOM | 28480 | 5063-0268 |
| A18MP1 | 5062-7095 | 1 | CRT WIRING ASSY (INCLUDES A18L1, A18W1) | 28480 | 5062-7095 |
| A18MP2 | 5041-3987 | 1 | SPACER, CRT | 28480 | 5041-3987 |
| A18V1 | 2090-0225 | 1 | TUBE, CRT | 28480 | 2090-0225 |
| A18W1 | | | P/O A18MP1 | | |
| | 5181-5046 | 1 | LABEL, CRT ADJUSTMENT | 28480 | 5181-5046 |

Table 4-9 Parts List, RF Section – 8560E and 8560EC (see Figure 4-4)

| Item | HP Part Number | Qty | Description | Mfr Code | Mfr Part Number |
|------|----------------|-----|--|----------|-----------------|
| 1 | 0515-2332 | 2 | SCREW-MACH M3 X 6MM-LG PAN-HD TORX | 28480 | 0515-2332 |
| 2 | 0515-1032 | 2 | SCREW-MACH M3 X 14MM-LG FLH-HD TORX | 28480 | 0515-1032 |
| 3 | 0515-2332 | 2 | SCREW-MACH M3 X 6MM-LG PAN-HD TORX | 28480 | 0515-2332 |
| 4 | 5021-7467 | 1 | FILTER CLAMP | 28480 | 5021-7467 |
| 6 | 0515-2332 | 2 | SCREW-MACH M3 X 6MM-LG PAN-HD TORX | 28480 | 0515-2332 |
| 7 | 5002-1008 | 1 | MAIN DECK | 28480 | 5002-1008 |
| 8 | 0515-1227 | 2 | SCREW-MACH M3 X 6MM-LG FLH-HD TORX | 28480 | 0515-1227 |
| 9 | 5001-8755 | 1 | FRONT END DECK | 28480 | 5001-8755 |
| 11 | 0515-1227 | 3 | SCREW-MACH M3 X 6MM-LG FLH-HD TORX | 28480 | 0515-1227 |
| 12 | 2360-0461 | 4 | SCREW-MACH 6-32 .375-IN-LG FLH-HD TORX | 28480 | 2360-0461 |
| 13 | 0515-0372 | 1 | SCREW-MACH M3 X 8MM-LG PAN-HD TORX | 28480 | 0515-0372 |
| 14 | 0515-1250 | 2 | SCREW-MACH M3 X 6MM-LG PAN-HD TORX | 28480 | 0515-1250 |
| 15 | 5001-8731 | 1 | ATTENUATOR BRACKET | 28480 | 5001-8731 |
| 18 | 08560-00002 | 1 | ATTENUATOR BRACKET | 28480 | 08560-00002 |
| 19 | 0515-1250 | 2 | SCREW-MACH M3 X 6MM-LG PAN-HD TORX | 28480 | 0515-1250 |
| 20 | 0515-1227 | 1 | SCREW-MACH M3 X 6MM-LG FLH-HD TORX | 28480 | 0515-1227 |
| 22 | 0515-1227 | 4 | SCREW-MACH M3 X 6MM-LG FLH-HD TORX | 28480 | 0515-1227 |
| 23 | 0515-1410 | 2 | SCREW-MACH M3 X 20MM-LG PAN-HD TORX | 28480 | 0515-1410 |

Table 4-10 Parts List, Front Frame – 8560EC (see Figure 4-9)

| Item | HP Part Number | Qty | Description | Mfr Code | Mfr Part Number |
|------|----------------|-----|---|----------|-----------------|
| 1 | 08560-80037 | 1 | DRESS PANEL OVERLAY | 28480 | 08560-80037 |
| | 08560-80039 | 1 | DRESS PANEL OVERLAY - OPTION 002 | 28480 | 08560-80039 |
| 2 | 08560-80039 | | CONNECTOR DRESS PANEL OVERLAY | | 08560-80039 |
| 4 | 0370-3069 | 1 | KNOB BASE 1-1/8 JGK .252-IN-IO (INCLUDES ITEM 5) | 28480 | 0370-3069 |
| 5 | 3030-0022 | 2 | SCREW-SET 6-32 .125-IN-LG SMALL CUP-PT | 00000 | DESCRIBE |
| 6 | 2950-0043 | 1 | NUT-HEX-DBL-CHAM 3/8-32-THD .094-IN-THK | 00000 | DESCRIBE |
| 7 | 2190-0016 | 1 | WASHER-LK INTL T 3/8 IN .377-IN-ID | 28480 | 2190-0016 |
| 8 | 5181-8246 | 1 | FRONT PANEL-DRESS | 28480 | 5181-8246 |
| 9 | 5060-0467 | 1 | PROBE POWER JACK | 28480 | 5060-0467 |
| 10 | 0590-1251 | 1 | NUT-SPCLY 15/32-32-THD .1-IN-THK .562-WD | 00000 | DESCRIBE |
| | 6960-0171 | 1 | PLUG-HOLE (Opt. 327)(not shown) | 28480 | 6960-0171 |
| 11 | 1250-1666 | 2 | ADAPTOR COAX STR F-SMA F-SMA | 28480 | 1250-1666 |
| 12 | 0515-2145 | 12 | SCREW-MACH M3 X 0.5 8MM-LG PAN-HD TX | 28480 | 0515-2145 |
| 13 | 5062-4806 | 1 | BUMPER KIT (Includes 4 bumpers) | 28480 | 5062-4806 |
| 15 | 5021-5483 | 2 | CATCH LATCH | 28480 | 5021-5483 |
| 16 | 0515-0366 | 4 | SCREW-MACH M2.5 X 0.45 6MM-LG PAN-HD TX | 28480 | 0515-0366 |
| 17 | 5022-0199 | 1 | FRONT FRAME | 28480 | 5022-0199 |
| 18 | 8160-0520 | 1 | RFI ROUND STRIP STL MSH/SIL RBR CU/SN | 28480 | 8160-0520 |

Table 4-10 Parts List, Front Frame – 8560EC (see Figure 4-9)

| Item | HP Part Number | Qty | Description | Mfr Code | Mfr Part Number |
|------|----------------|-------|--|----------|-----------------|
| 19 | 2950-0154 | 1(2) | NUT (use 2 for 002 instruments) | 28480 | 2950-0154 |
| 20 | 2190-0016 | 1 | WASHER-LK INTL T 3/8 IN .377-IN-ID | 28480 | 2190-0016 |
| 21 | 2950-0043 | 1 | NUT-HEX-DBL-CHAM 3/8-32-THD .094-IN-THK | 00000 | DESCRIBE |
| 22 | 1250-1811 | 1 | ADAPTER N(f) SMA (f) (Standard) | 28480 | 1250-2191 |
| 22 | 1250-1811 | 2 | ADAPTER N(f) SMA (f) (Option 002) | 28480 | 1250-2191 |
| 23 | 5022-3711 | 1 (2) | WASHER (use 2 for 002 instruments) | 28480 | 0515-0430 |
| 24 | 5041-9630 | | RUBBER KEYPAD (INCLUDES KEYCAPS) | 28480 | 5041-9630 |
| 25 | 1990-1131 | 1 | LED-LAMP LUM-INT=560UCD IF=20MA-MAX | 2M627 | LD-101MG |
| 26 | 5063-3966 | 1 | LINE SWITCH CABLE ASSEMBLY | 28480 | 5063-3966 |
| 27 | 0900-0010 | 1 | O-RING .101-IN-ID .07-IN-XSECT-DIA NTRL | 51633 | AS568-005 |
| 28 | 0515-0664 | 1 | SCREW-MACHINE ASSEMBLYM3 X0.5 12MM-LG | 28480 | 0515-0664 |
| 31 | 0515-1934 | 7 | SCREW-MACH M2.5 X 0.45 6MM-LG PAN-HD TX (P/O A1W1) | 28480 | 0515-1934 |
| 32 | 2100-4232 | 1 | R-VC 20K 20% LOG | 28480 | 2100-4232 |
| 33 | 3050-0014 | 2 | WASHER-FL .250ID12 | 28480 | 3050-0014 |
| 34 | 2190-0067 | 1 | WASHER-LK INTL .256-IN-ID | 28480 | 2190-0067 |
| 35 | 2950-0072 | 1 | NUT-HEX 1/4-32 THD | 28480 | 2950-0072 |
| 36 | 0370-3079 | 1 | KNOB RND .125 JG | 28480 | 0370-3079 |

Table 4-11 Parts List, Front Frame – 8560E (see Figure 4-5)

| Item | HP Part Number | Qty | Description | Mfr Code | Mfr Part Number |
|------|----------------|-----|---|----------|-----------------|
| 1 | 0515-1622 | 4 | SCREW-SKT-HD-CAP M4 X 0.7 8MM-LG | 28480 | 0515-1622 |
| 2 | 5041-8906 | 1 | CRT BEZEL | 28480 | 5041-8906 |
| 3 | 1000-0897 | 1 | RFI CRT FACEPLATE | 28480 | 1000-0897 |
| 4 | 0370-3069 | 1 | KNOB BASE 1-1/8 JGK .252-IN-IO (INCLUDES 5) | 28480 | 0370-3069 |
| 5 | 3030-0022 | 2 | SCREW-SET 6-32 .125-IN-LG SMALL CUP-PT | 00000 | DESCRIBE |
| 6 | 2950-0043 | 1 | NUT-HEX-DBL-CHAM 3/8-32-THD .094-IN-THK | 00000 | DESCRIBE |
| 7 | 2190-0016 | 1 | WASHER-LK INTL T 3/8 IN .377-IN-ID | 28480 | 2190-0016 |
| 8 | 08560-00011 | 1 | FRONT PANEL-DRESS (Standard) | 28480 | 08560-00011 |
| 8 | 08560-00010 | 1 | FRONT PANEL-DRESS (Option 002) | 28480 | 08560-00010 |
| 9 | 5060-0467 | 1 | PROBE POWER JACK | 28480 | 5060-0467 |
| 10 | 0590-1251 | 1 | NUT-SPCLY 15/32-32-THD .1-IN-THK .562-WD | 00000 | DESCRIBE |
| | 6960-0171 | 1 | PLUG-HOLE (Opt. 327)(not shown) | 28480 | 6960-0171 |
| 11 | 1250-1666 | 2 | ADAPTOR COAX STR F-SMA F-SMA | 28480 | 1250-1666 |
| 12 | 0515-2145 | 12 | SCREW-MACH M3 X 0.5 8MM-LG PAN-HD TX | 28480 | 0515-2145 |
| 13 | 5062-4806 | 1 | BUMPER KIT (Includes 4 bumpers) | 28480 | 5062-4806 |
| 14 | 0905-1018 | 4 | O-RING .126TD | 28480 | 0905-1018 |
| 15 | 5021-5483 | 2 | CATCH LATCH | 28480 | 5021-5483 |
| 16 | 0515-0366 | 4 | SCREW-MACH M2.5 X 0.45 6MM-LG PAN-HD TX | 28480 | 0515-0366 |
| 17 | 5022-0199 | 1 | FRONT FRAME | 28480 | 5022-0199 |
| 18 | 8160-0520 | 1 | RFI ROUND STRIP STL MSH/SIL RBR CU/SN | 28480 | 8160-0520 |

Table 4-11 Parts List, Front Frame – 8560E (see Figure 4-5)

| Item | HP Part Number | Qty | Description | Mfr Code | Mfr Part Number |
|------|----------------|-----|---|----------|-----------------|
| 19 | 0535-0082 | 2 | NVTM W LKWR M4 | 28480 | 0535-0082 |
| 20 | 2190-0016 | 1 | WASHER-LK INTL T 3/8 IN .377-IN-ID | 28480 | 2190-0016 |
| 21 | 2950-0043 | 1 | NUT-HEX-DBL-CHAM 3/8-32-THD .094-IN-THK | 00000 | DESCRIBE |
| 22 | 1250-2191 | 1 | ADAPTER N(f) SMA (f) (Standard) | 28480 | 1250-2191 |
| 22 | 1250-2191 | 2 | ADAPTER N(f) SMA (f) (Option 002) | 28480 | 1250-2191 |
| 23 | 0515-0430 | 2 | SCREW-MACH M3 X 0.5 8MM-LG PAN-HD TX | 28480 | 0515-0430 |
| 24 | 5041-8985 | 1 | RUBBER KEYPAD (INCLUDES KEYCAPS) | 28480 | 5041-8985 |
| 25 | 1990-1131 | 1 | LED-LAMP LUM-INT=560UCD IF=20MA-MAX | 2M627 | LD-101MG |
| 26 | 5062-0728 | 1 | LINE SWITCH CABLE ASSEMBLY | 28480 | 5062-0728 |
| 27 | 0900-0010 | 1 | O-RING .101-IN-ID .07-IN-XSECT-DIA NTRL | 51633 | AS568-005 |
| 28 | 0515-0664 | 1 | SCREW-MACHINE ASSEMBLYM3 X0.5 12MM-LG | 28480 | 0515-0664 |
| 29 | 5021-5482 | 1 | SUPPORT CENTER | 28480 | 5021-5482 |
| 30 | 0515-1143 | 2 | SCREW-MACH M4 X 0.7 16MM-LG PAN-HD TX | 28480 | 0515-1143 |
| 31 | 0515-1934 | 9 | SCREW-MACH M2.5 X 0.45 6MM-LG PAN-HD TX (P/O A1W1) | 28480 | 0515-1934 |
| 32 | 2100-4232 | 1 | R-VC 20K 20% LOG | 28480 | 2100-4232 |
| 33 | 3050-0014 | 2 | WASHER-FL .250ID12 | 28480 | 3050-0014 |
| 34 | 2190-0067 | 1 | WASHER-LK INTL .256-IN-ID | 28480 | 2190-0067 |
| 35 | 2950-0072 | 1 | NUT-HEX 1/4-32 THD | 28480 | 2950-0072 |
| 36 | 0370-3079 | 1 | KNOB RND .125 JG | 28480 | 0370-3079 |

Table 4-12 Parts List, Rear Frame – 8560EC (see Figure 4-10)

| Item | HP Part Number | Qty | Description | Mfr Code | Mfr Part Number |
|------|----------------|-----|--|----------|-----------------|
| 1 | 0515-1946 | 2 | SCREW-MACH M3 6MM-LG FLH-HD TORX | 28480 | 0515-1946 |
| 2 | 5062-7755 | 1 | BATTERY HOLDER (INCLUDES WIRES) | 28480 | 5062-7755 |
| 3 | 0515-2216 | 4 | SCREW-MACH M4 40MM-LG PAN-HD TORX | 28480 | 0515-2216 |
| 4 | 3160-0309 | 1 | FAN GRILL | 28480 | 3160-0309 |
| 5 | 0380-0012 | 4 | SPACER-RND .875-IN-ID | 28480 | 0380-0012 |
| 6 | | | NOT ASSIGNED | | |
| 7 | 6960-0149 | 1 | PLUG-HOLE TR-HD FOR 0.5-D-HOLE STL | 05093 | 6960-0149 |
| 8 | 6960-0023 | 1 | PLUG-HOLE DOME-HD FOR 0.312-D-HOLE STL | 04213 | D-2730-LC2 |
| 9 | 1250-1753 | 1 | ADAPTOR-COAX STR F-SMA OPT 001 (INCLUDES WASHER AND NUT) | 28480 | 1250-1753 |
| 10 | 0515-1946 | 4 | SCREW-MACH M3 6MM-LG FLH-HD TORX | 28480 | 0515-1946 |
| 11 | 0515-0684 | 1 | SCREW-MACH M3 6MM-LG PAN-HD TORX | 28480 | 0515-0684 |
| 12 | 2950-0035 | 5 | NUT HEX 15/32THD | 28480 | 2950-0035 |
| 13 | 5062-4838 | 1 | CONNECTOR-TEL 2-CKT .141-SHK-DIA (INCLUDES NUT AND JACK) PART OF W5 | 28480 | 5062-4838 |
| 14 | 5002-4049 | 1 | REAR PANEL-DRESS | 28480 | 5002-4049 |
| 15 | 0515-2145 | 4 | SCREW-MACH M3 6MMLG PAN-HD TORX | 28480 | 0515-2145 |
| 16 | 8160-0520 | 1 | RFI ROUND STRIP STL SPIRA .150 | 28480 | 8160-0520 |

Table 4-12 Parts List, Rear Frame – 8560EC (see Figure 4-10)

| Item | HP Part Number | Qty | Description | Mfr Code | Mfr Part Number |
|------|----------------|-----|--|----------|-----------------|
| 17 | 5022-3778 | 1 | REAR FRAME | 28480 | 5022-3778 |
| 18 | 5021-6391 | 2 | SCREW-CONNECTOR HP-IB | 28480 | 5021-6391 |
| 19 | 2200-0225 | 2 | SCREW-MACH 4-40 .25-IN-LG TORX | 28480 | 2200-0225 |
| 20 | 0535-0082 | 2 | NUT M4.0 W/LOCKWR | 28480 | 0535-0082 |
| 21 | 0515-0433 | 1 | SCREW-MACH M4 8MM-LG PAN-HD TORX | 28480 | 0515-0433 |
| 22 | 0535-0023 | 2 | NUT-HEX DBL-CHAM M4 X 0.7 3.2MM-THK | 28480 | 0535-0023 |
| 23 | 8121-0062 | 1 | VGA CONNETOR AND CABLE | 28480 | 8121-0062 |
| B1 | 5061-9036 | 1 | FAN ASSEMBLY (INCLUDES WIRE) | 28480 | 5061-9036 |
| BT1 | 1420-0341 | 1 | BATTERY 3.0V 1.2A-HR LITHIUM POLYCARBON MONOFLOURIDE | 08709 | BR 2/3A SSP |

Table 4-13 Parts List, Rear Frame – 8560E (see Figure 4-7)

| Item | HP Part Number | Qty | Description | Mfr Code | Mfr Part Number |
|------|----------------|-----|---|----------|-----------------|
| 1 | 0515-1946 | 2 | SCREW-MACH M3 6MM-LG FLH-HD TORX | 28480 | 0515-1946 |
| 2 | 5062-7755 | 1 | BATTERY HOLDER (INCLUDES WIRES) | 28480 | 5062-7755 |
| 3 | 0515-2216 | 4 | SCREW-MACH M4 40MM-LG PAN-HD TORX | 28480 | 0515-2216 |
| 4 | 3160-0309 | 1 | FAN GRILL | 28480 | 3160-0309 |
| 5 | 0380-0012 | 4 | SPACER-RND .875-IN-ID | 28480 | 0380-0012 |
| 6 | | | NOT ASSIGNED | | |
| 7 | 6960-0149 | 1 | PLUG-HOLE TR-HD FOR 0.5-D-HOLE STL | 05093 | 6960-0149 |
| 8 | 6960-0023 | 1 | PLUG-HOLE DOME-HD FOR 0.312-D-HOLE STL | 04213 | D-2730-LC2 |
| 9 | 1250-1753 | 1 | ADAPTOR-COAX STR F-SMA OPT 001 (INCLUDES WASHER AND NUT) | 28480 | 1250-1753 |
| 10 | 0515-1946 | 4 | SCREW-MACH M3 6MM-LG FLH-HD TORX | 28480 | 0515-1946 |
| 11 | 0515-0684 | 1 | SCREW-MACH M3 6MM-LG PAN-HD TORX | 28480 | 0515-0684 |
| 12 | 2950-0035 | 5 | NUT HEX 15/32THD | 28480 | 2950-0035 |
| 13 | 5062-4838 | 1 | CONNECTOR-TEL 2-CKT .141-SHK-DIA (INCLUDES NUT AND JACK) PART OF W5 | 28480 | 5062-4838 |
| 14 | 5002-1012 | 1 | REAR PANEL-DRESS | 28480 | 5002-1012 |
| 15 | 0515-2145 | 4 | SCREW-MACH M3 6MMLG PAN-HD TORX | 28480 | 0515-2145 |
| 16 | 8160-0520 | 1 | RFI ROUND STRIP STL SPIRA .150 | 28480 | 8160-0520 |
| 17 | 5021-5479 | 1 | REAR FRAME | 28480 | 5021-5479 |
| 18 | 5021-6391 | 2 | SCREW-CONNECTOR HP-IB | 28480 | 5021-6391 |
| 19 | 2200-0225 | 2 | SCREW-MACH 4-40 .25-IN-LG TORX | 28480 | 2200-0225 |
| 20 | 0535-0082 | 2 | NUT M4.0 W/LOCKWR | 28480 | 0535-0082 |
| 21 | 0515-0433 | 1 | SCREW-MACH M4 8MM-LG PAN-HD TORX | 28480 | 0515-0433 |
| 22 | 0535-0023 | 2 | NUT-HEX DBL-CHAM M4 X 0.7 3.2MM-THK | 28480 | 0535-0023 |
| B1 | 5061-9036 | 1 | FAN ASSEMBLY (INCLUDES WIRE) | 28480 | 5061-9036 |
| BT1 | 1420-0341 | 1 | BATTERY 3.0V 1.2A-HR LITHIUM POLYCARBON MONOFLOURIDE | 08709 | BR 2/3A SSP |

Figure 4-2 **Parts Identification, Cover Assembly**

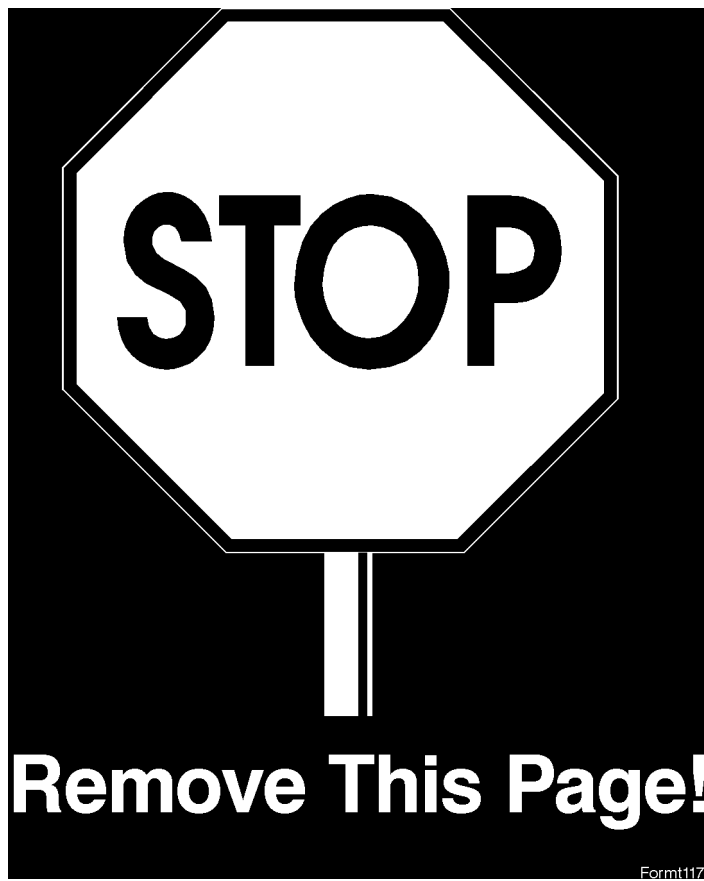

Replace with sj16c

Replaceable Parts
Firmware-Dependent Part Numbers

Figure 4-3 **Parts Identification, Main Chassis (8560E)**

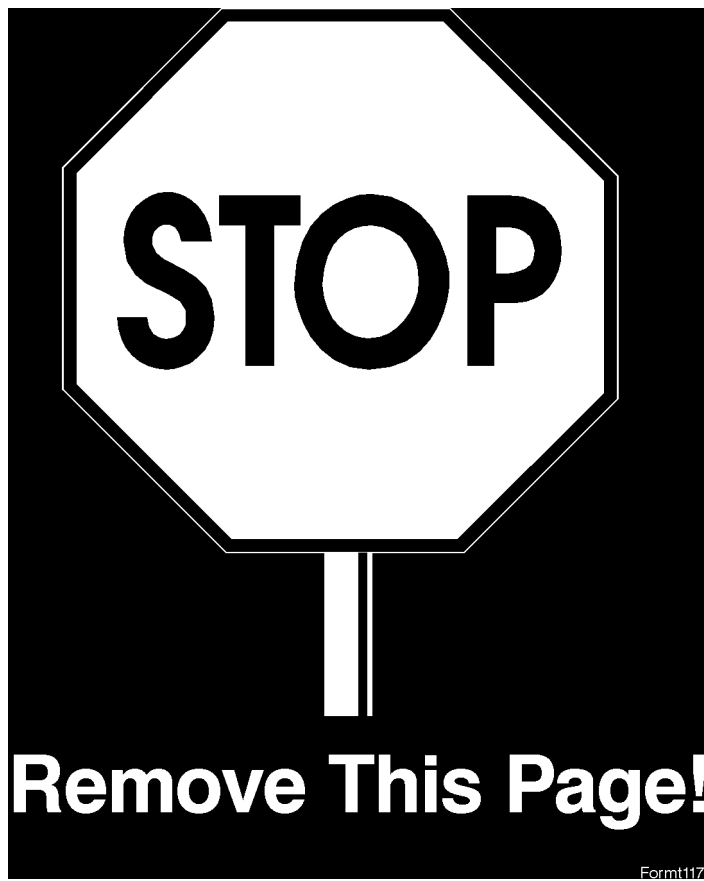

Replace with sp11c

Replaceable Parts
Firmware-Dependent Part Numbers

Figure 4-4 **Parts Identification, RF Section**

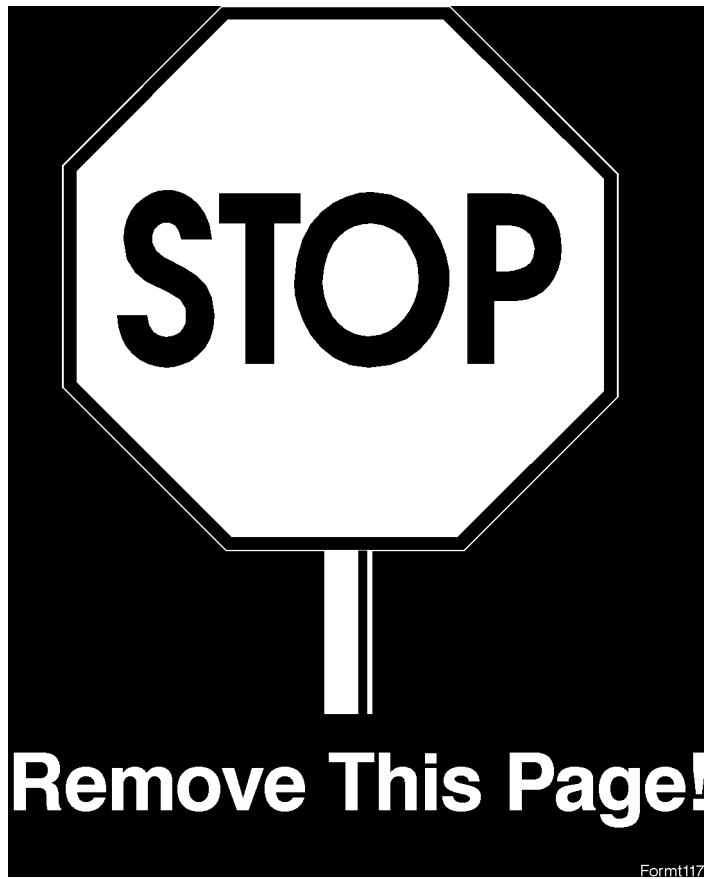

Replace with sj128c

Replaceable Parts
Firmware-Dependent Part Numbers

Figure 4-5 **Parts Identification, Front Frame (1 of 2), 8560E**

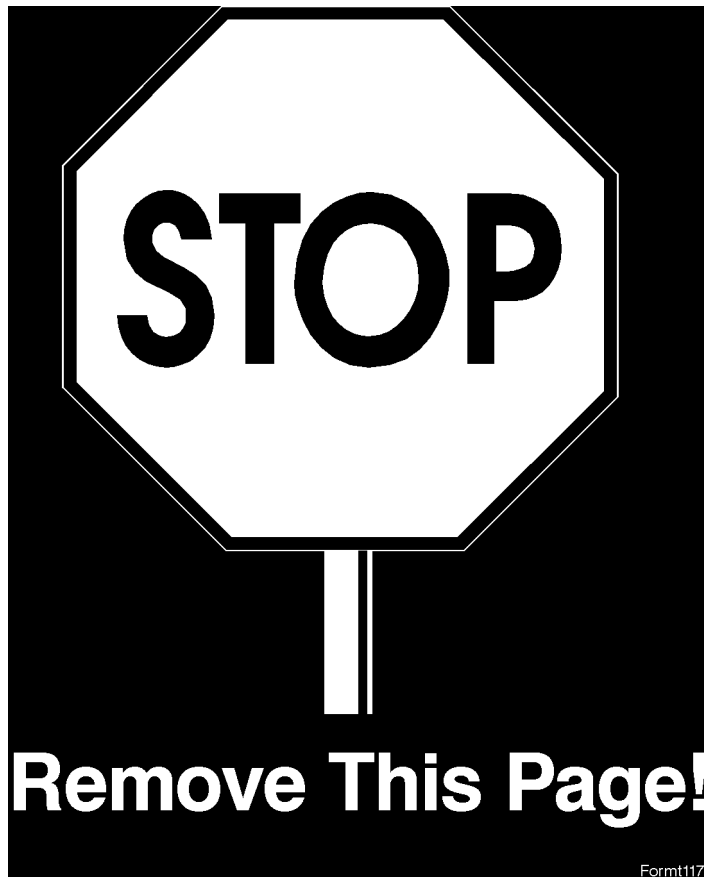

Replace with sj163e

Replaceable Parts
Firmware-Dependent Part Numbers

Figure 4-5 **Parts Identification, Front Frame (2 of 2), Option 002**

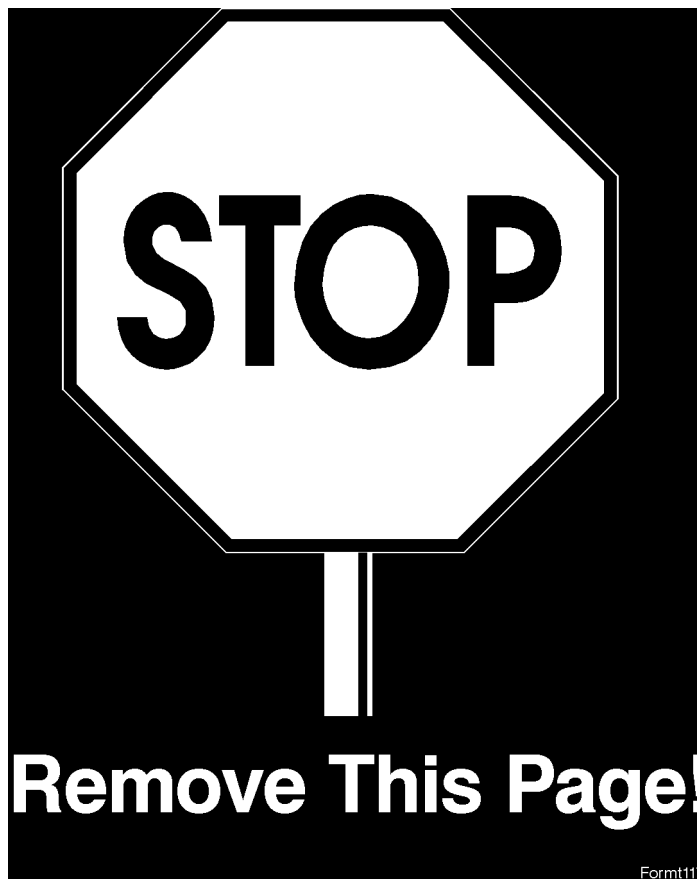

Replace with sj162e

Replaceable Parts
Firmware-Dependent Part Numbers

Figure 4-6 **Parts Identification, Rear Frame (8560E)**

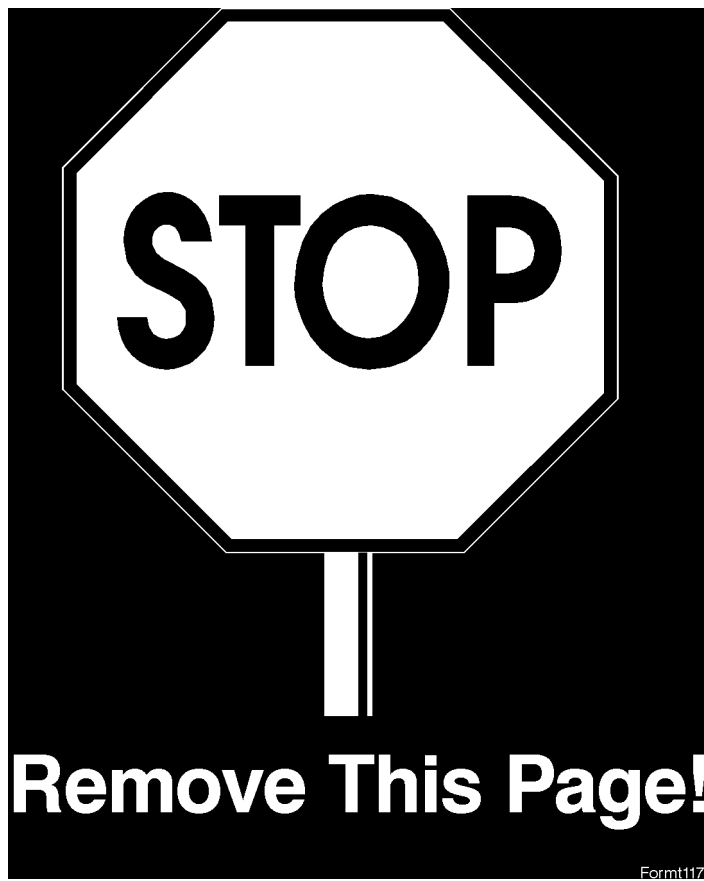

Replace with sj11c

Replaceable Parts
Firmware-Dependent Part Numbers

Figure 4-7 **Parts Identification, Chassis (8560EC)**

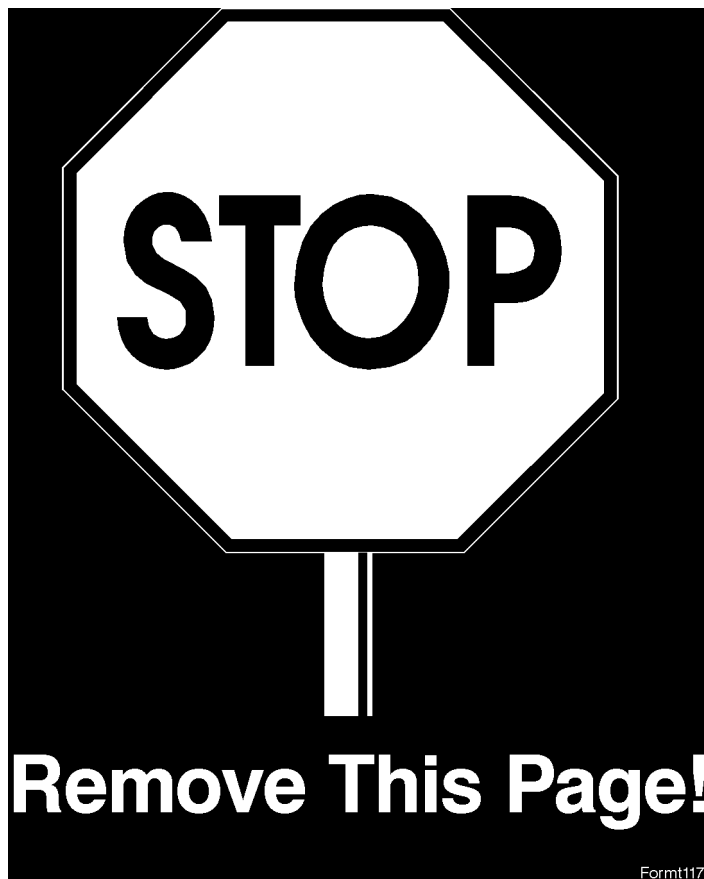

Replace with sj120c

Replaceable Parts
Firmware-Dependent Part Numbers

Figure 4-8 **Parts Identification, Front Frame (8560EC)**

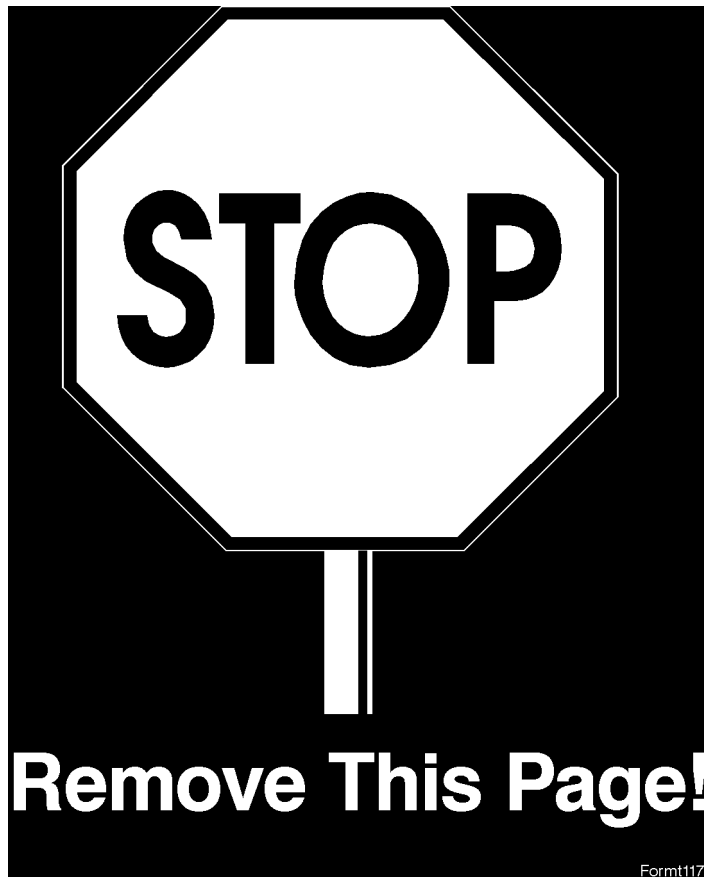

Replace with sj125c

Replaceable Parts
Firmware-Dependent Part Numbers

Figure 4-9 **Parts Identification, Rear Frame (8560EC)**

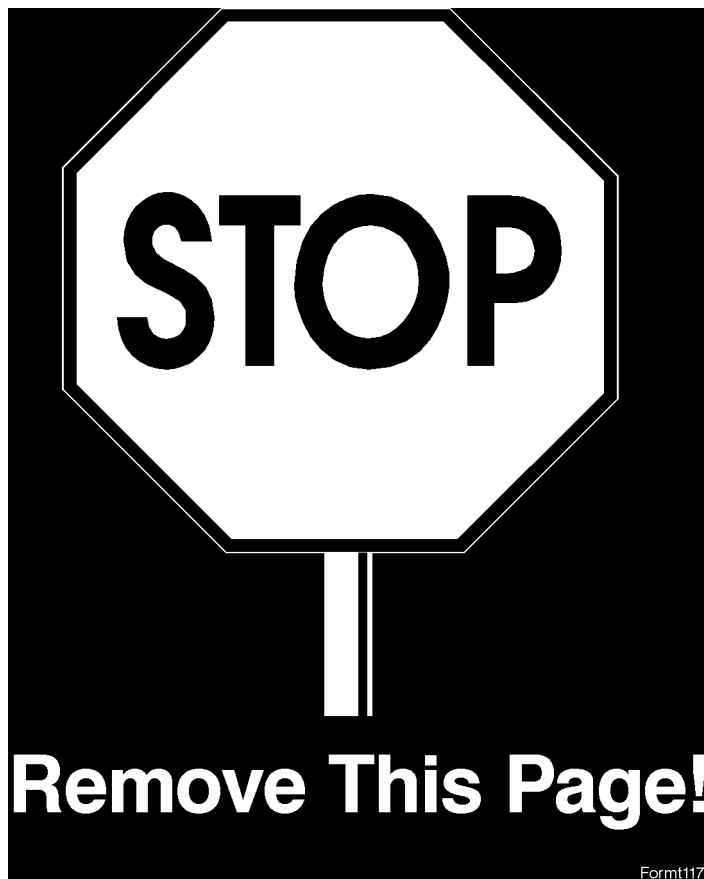

replace with sj119c

Replaceable Parts
Firmware-Dependent Part Numbers

5

Major Assembly and Cable Locations

Introduction

This chapter identifies instrument cables and assemblies, and contains the following figures:

| | |
|---|----------|
| Figure 5-1. Hinged Assemblies..... | page 270 |
| Figure 5-2. Top View (A2 and A3 Unfolded) EC-series | page 271 |
| Figure 5-3. Top View (A2, A3, A4, A5 Unfolded) EC-series..... | page 272 |
| Figure 5-4. Top View (A2 Unfolded) E-series | page 273 |
| Figure 5-5. Top View (A2 and A3 Unfolded) E-series..... | page 274 |
| Figure 5-6. Top View (A2, A3, A4,A5 Unfolded) E-series.. | page 275 |
| Figure 5-7 Bottom View (A15 Unfolded)..... | page 276 |
| Figure 5-8. Bottom View (A15 and A14 Unfolded)..... | page 277 |
| Figure 5-9. Front End | page 278 |
| Figure 5-10. Rear View - EC-series..... | page 279 |
| Figure 5-11. Rear View - E-series..... | page 279 |

NOTE

Diagrams that illustrate features common to E-series and EC-series instruments are shown with E-series instruments. Where there are differences between E-series and EC-series features, separate diagrams are provided for E-series and for EC-series instruments.

Use the list below to determine the figure(s) illustrating the desired assembly or cable.

| Assemblies | Figure |
|---|----------------|
| A1 Front Frame | 5-8 |
| A1A1 Keyboard | 5-8 |
| A2 Controller | 5-3, 5-4 |
| A3 Interface | 5-1, 5-4 |
| A4 Log Amplifier/Cal Oscillator | 5-1, 5-5 |
| A5 IF Filter | 5-1, 5-6 |
| A6 Power Supply | 5-6 |
| A6A1 High Voltage Module | 5-6 |
| A7 LO Distribution Amplifier | 5-7 |
| A8 Low Band Mixer | 5-7 |
| A9 RF Attenuator | 5-7 |
| A10 Tracking Generator (Option 002) | 5-7 |
| A11 YTO | 5-7 |
| A12 | (Not Assigned) |
| A13 Second Converter | 5-7 |
| A14 Frequency Control | 5-1, 5-8 |
| A15 RF | 5-1, 5-7, 5-8 |
| A16 Fast ADC (Option 007) | 5-4, 5-6 |
| A17 LCD Driver | |
| A17 CRT Driver | 5-6 |
| A18 LCD Assembly | |
| A18 CRT Assembly | 5-6 |

| | |
|----------------------------|------|
| A19 HP-IB | 5-6 |
| A20 Battery Assembly | 5-10 |
| A21 OCXO | 5-6 |
| B1 Fan | 5-10 |
| BT1 Battery | 5-10 |
| FL1 Low Pass Filter | 5-7 |
| FL2 Low Pass Filter | 5-7 |
| FL3 Line Filter | 5-10 |
| LS1 Speaker | 5-6 |

| | |
|--|--------------------|
| Cables | Figure |
| A1A1W1 Keyboard Cable | 5-4, 5-6 |
| A3W1 Interface Cable | 5-4 |
| A19W1 HP-IB Cable | 5-4, 5-6 |
| W1 Power Cable | 5-4, 5-5, 5-6, 5-7 |
| W2 Control Cable | 5-4, 5-5, 5-6, 5-7 |
| W3 Line Switch Cable | 5-6, 5-9 |
| W4 Option Module Cable | 5-6 |
| W5 | (NOT ASSIGNED) |
| W6 Battery Cable | 5-4 |
| W7 Display/FADC Cable | 5-4 |
| W8 Display Power Cable | 5-6 |
| W9 CRT Yoke Cable | 5-6 |
| W10 YTO Drive Cable | 5-8, 5-9 |
| W11 Attenuator Drive Cable | 5-6 |
| W12 A7 LODA Drive Cable | 5-8, 5-9 |
| W13 A13 Second Conv. Drive Cable | 5-8 |
| W14 A10 Control Signal Cable (Option 002) | 5-8, 5-9 |
| W15 | (NOT ASSIGNED) |
| W16 A10 ALC EXT Cable (Option 002) | 5-8, 5-9 |
| W17 | (NOT ASSIGNED) |
| W18 LO Sweep (coax 97) | 5-8 |
| W19 Second IF Out (coax 83) (Option 001) | 5-75-7 |
| W20 Zero-Span Video (coax 6) | 5-4 |
| W21 | (NOT ASSIGNED) |
| W22 10 MHz Freq. Count (coax 0) | 5-4, 5-7 |
| W23 Ext. Trigger In (coax 93) | 5-4 |
| W24 Video Out (coax 5) (Deleted in Opt. 327) | 5-4 |
| W25 Blanking Out (coax 4) | 5-4 |
| W26 | (NOT ASSIGNED) |
| W27 Filter 10.7 MHz | 5-55-5, 5-6 |
| W28 | (NOT ASSIGNED) |
| W29 10.7 IF (coax 7) | 5-6, 5-7 |
| W30 | (NOT ASSIGNED) |
| W31 Ref. In/Out (coax 8) | 5-7 |
| W32 Sampler IF (coax 87) | 5-7, 5-8 |
| W33 Second LO Drive (coax 81) | 5-7, 5-9 |
| W34 First LO Samp. (coax 0) | 5-7, 5-8, 5-9 |
| W35 Int Second IF (coax 92) | 5-7, 5-9 |

| | |
|--|----------|
| W36 Ext Second IF (coax 86) (Deleted in Opt. 002 and Opt. 327) | 5-7 |
| W37 10 MHz Ref 1 (coax 85) | 5-7, 5-8 |
| W38 Semirigid coax, A11J2 to A7J1 | 5-9 |
| W39 Semirigid coax, A7J2 to A8J3 | 5-9 |
| W40 Cal. Out (coax 89) | 5-7 |
| W41 Semirigid coax, front panel J1 to A9J1 | 5-9 |
| W42 Semirigid coax, A7J3 to front panel J4 (Standard) | 5-9 |
| W43 Semirigid coax, A7J3 to A10J4 (Option 002) | 5-9 |
| W44 Semirigid coax, A9J2 to FL1J1 | 5-9 |
| W45 Semirigid coax, FL1J2 to A8J1 | 5-9 |
| W46 Semirigid coax, A10J3 to front panel J4 (Option 002) | 5-9 |
| W47 Semirigid coax, A10J2 to front panel J6 (Option 002) | 5-9 |
| W48 A10 600 MHz (coax 80) (Option 002) | 5-7 |
| W49 OCXO 10 MHz output (coax 82) | 5-7 |
| W50 OCXO power (part of A21 OCXO assembly) | 5-7 |
| W51 10 MHz IN (coax 84) | 5-5, 5-7 |
| W52 CAL Oscillator Out (coax 9) | 5-6 |
| W53 Frequency Counter (coax 1) | 5-4, 5-5 |
| W54 Video (coax 2) | 5-4, 5-5 |
| W55 Audio Out | 5-5, 5-6 |
| W56 Semirigid coax, A8J2 to FL2J1 | 5-9 |
| W57 Semirigid coax, FL2J2 to A13J1 | 5-9 |
| W58 ALT SWEEP OUT (coax 8) | 5-8 |
| W59 FADC clock (coax 839) (8560E with Option 007) | 5-4 |
| W60 ribbon, A2J8 to A17J1 | 5-2,5-3 |
| W61 coax, A2J9 to A17 J7 | 5-2,5-3 |
| W62 ribbon, A17J6 to A17A1 | 5-2,5-3 |
| W63 ribbon, A17J5 to A18 | 5-2,5-3 |
| W64, A17J4 to J1 on the rear panel (VGA port) | 5-2,5-3 |

Figure 5-1 Hinged Assemblies

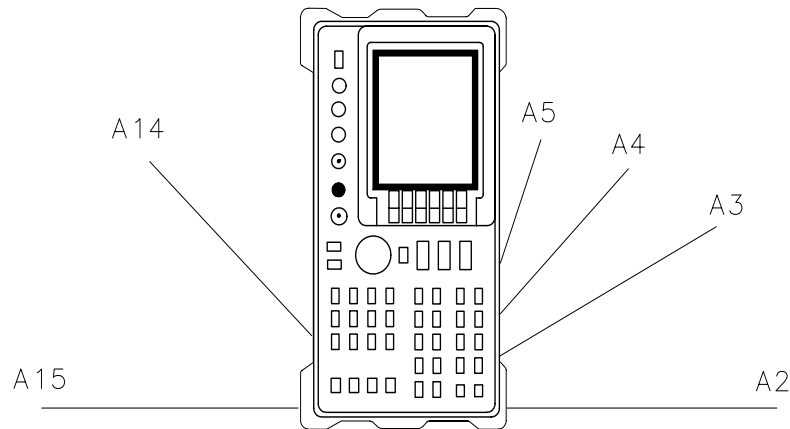

NOTE Figure 5-1 shows an 8560 E-series instrument. The 8560 EC-series instrument is identical except the A2 board is smaller.

Figure 5-2 Top View (A2 and A3 Unfolded) – EC-Series

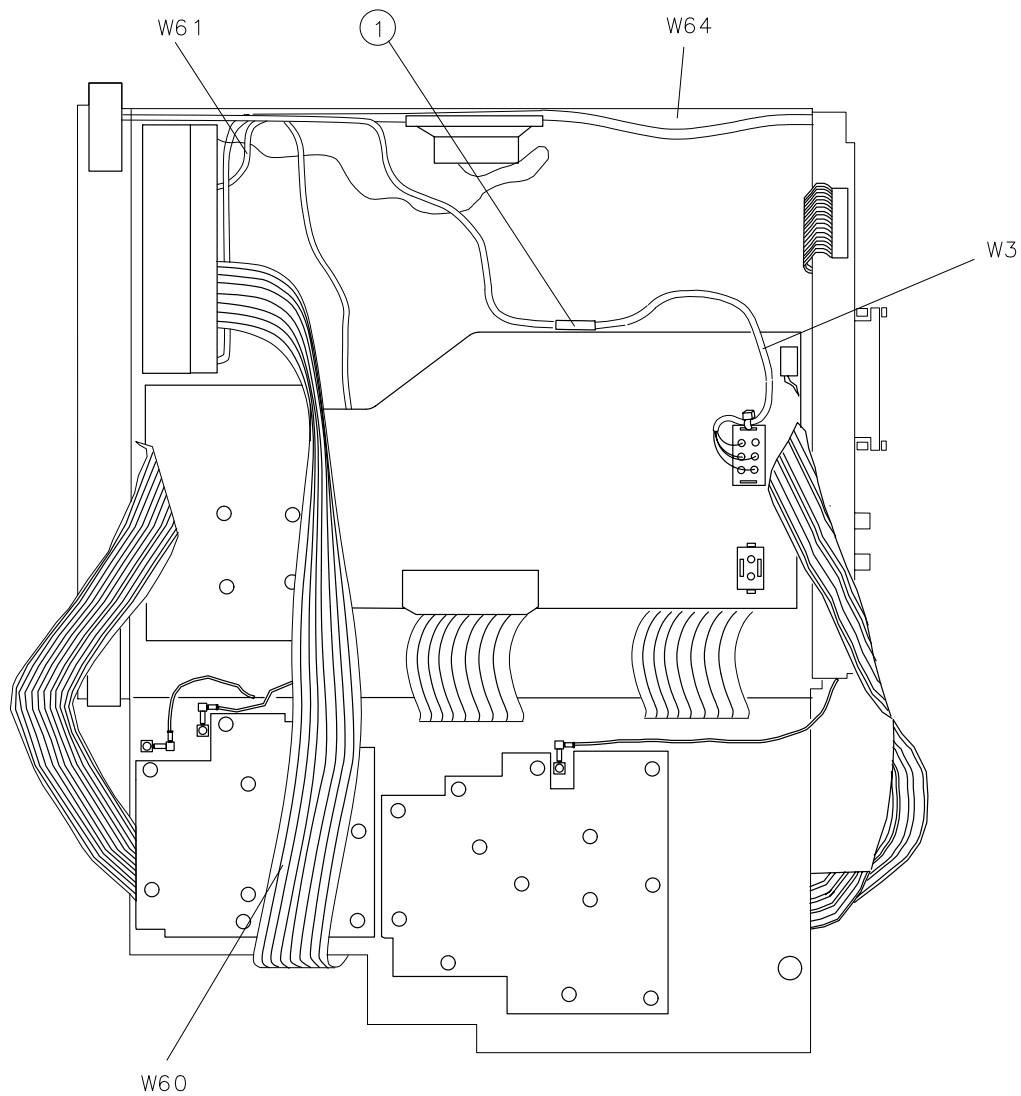

s 1115c

Figure 5-3 Top View (A2, A3, A4, and A5 Unfolded) – EC-Series

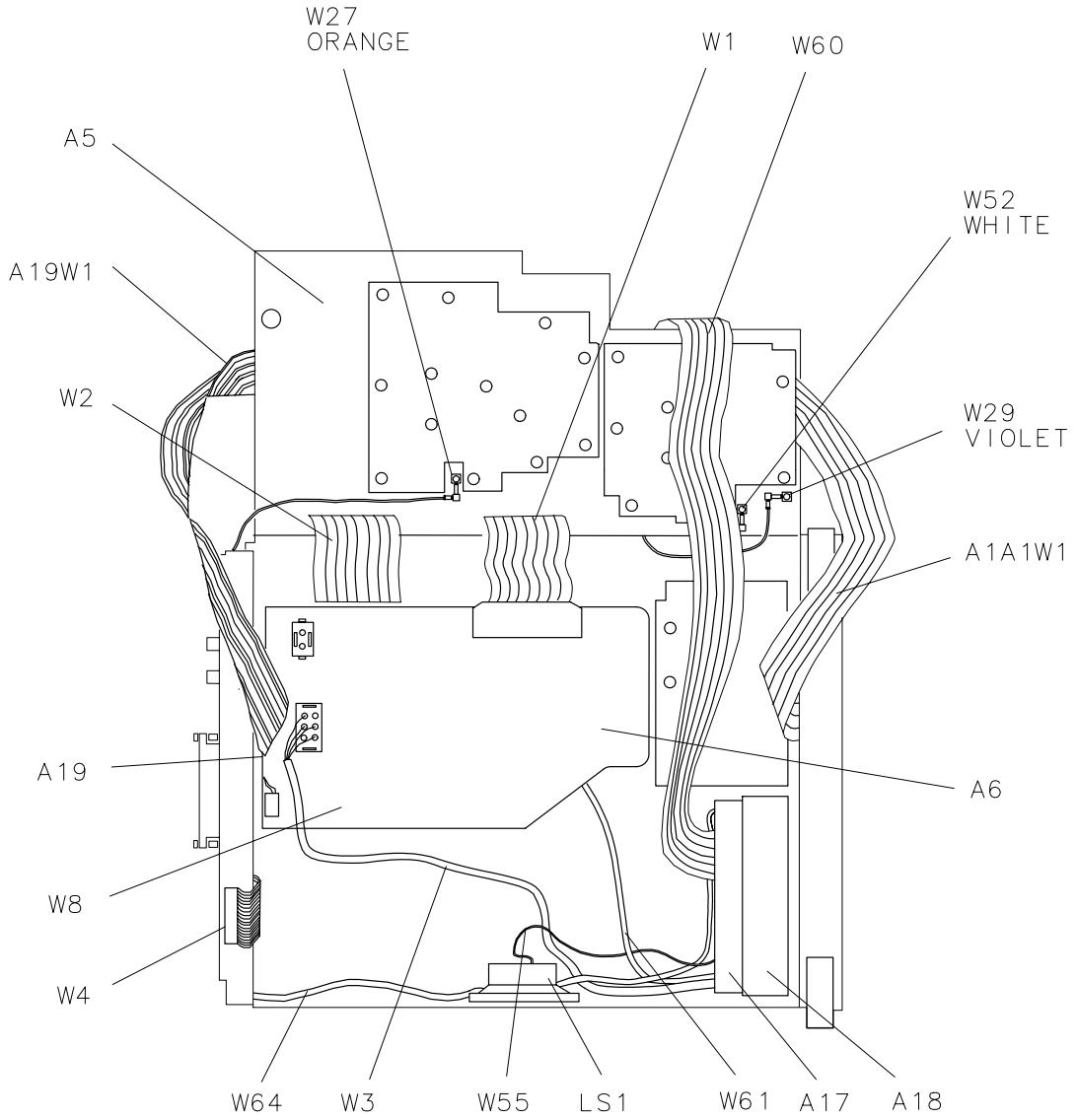

s1112c

Figure 5-4 Top View (A2 Unfolded) – E-Series

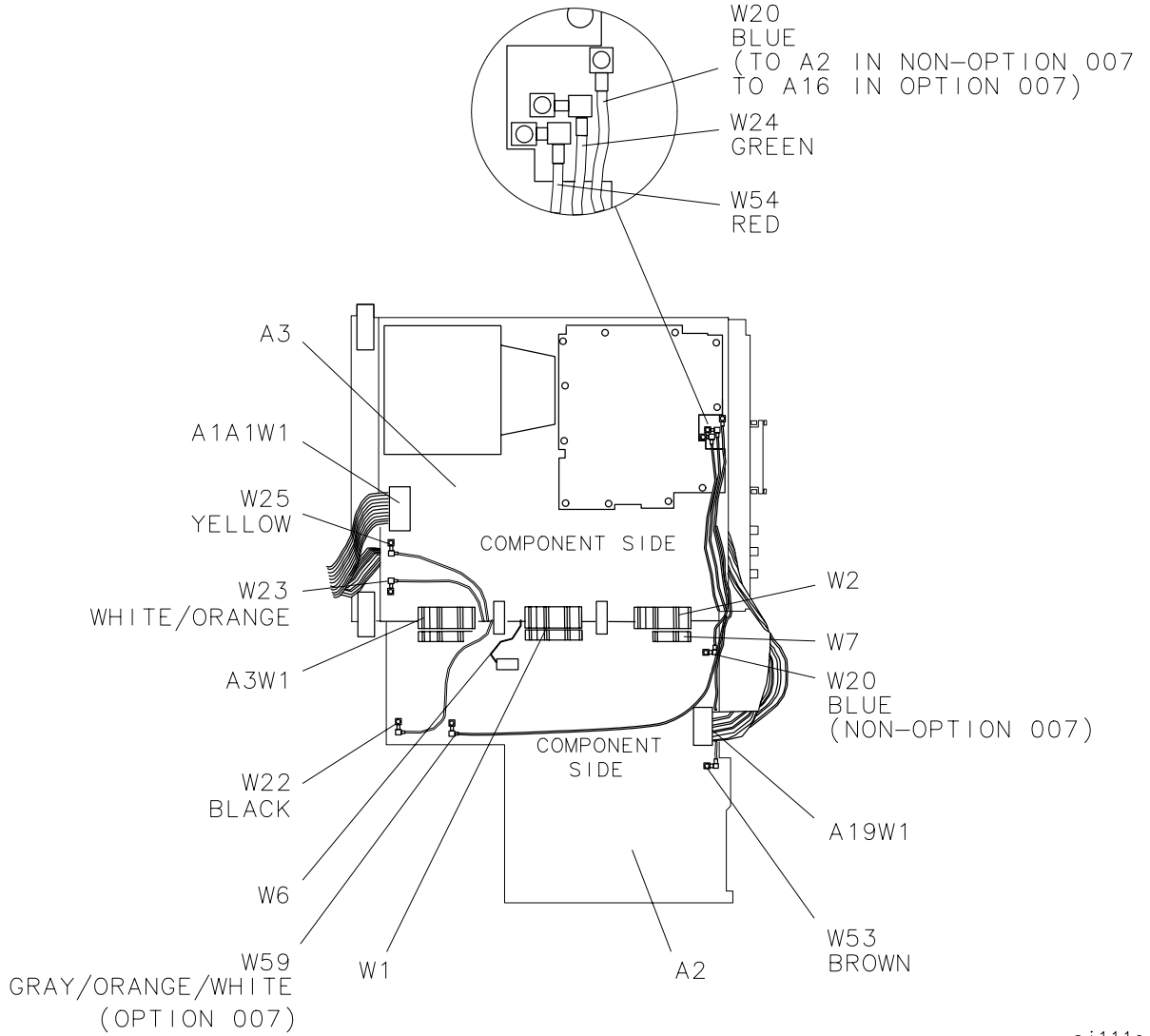

sj111e

Figure 5-5 Top View (A2 and A3 Unfolded) – E-Series

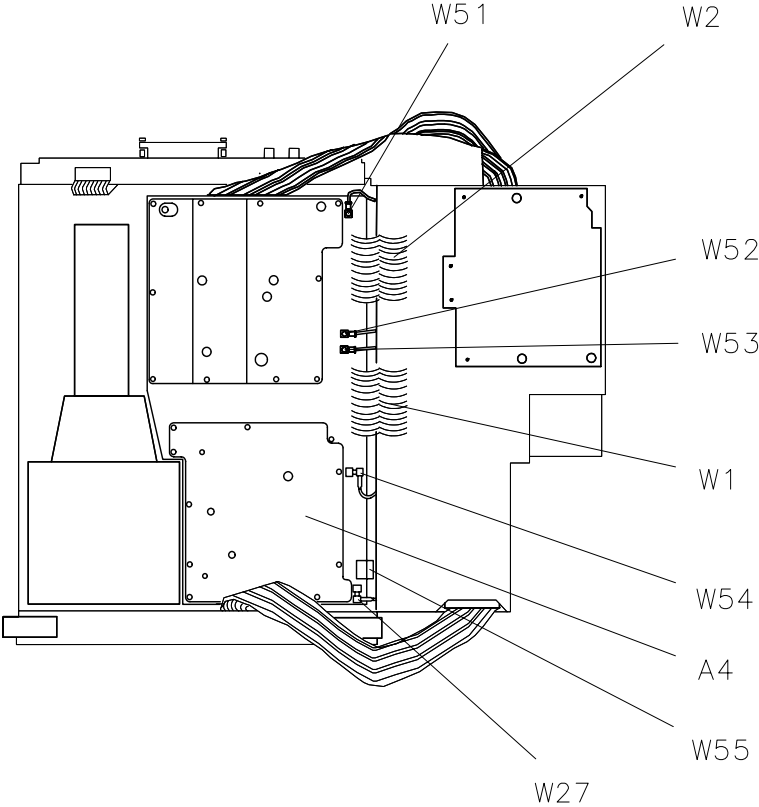

s

Figure 5-6 Top View (A2, A3, A4, and A5 Unfolded) – E-Series

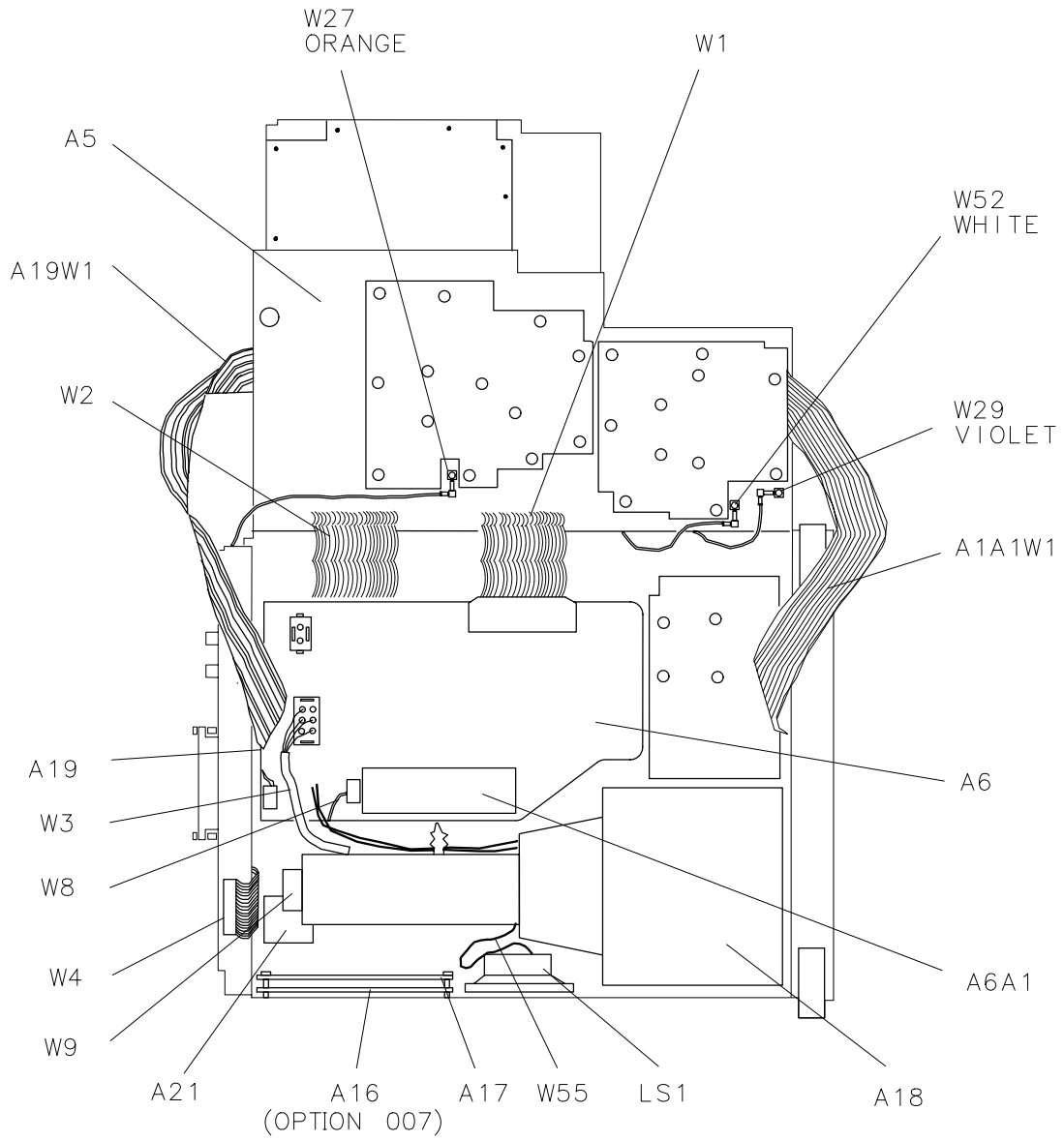

Figure 5-7 Bottom View (A15 Unfolded)

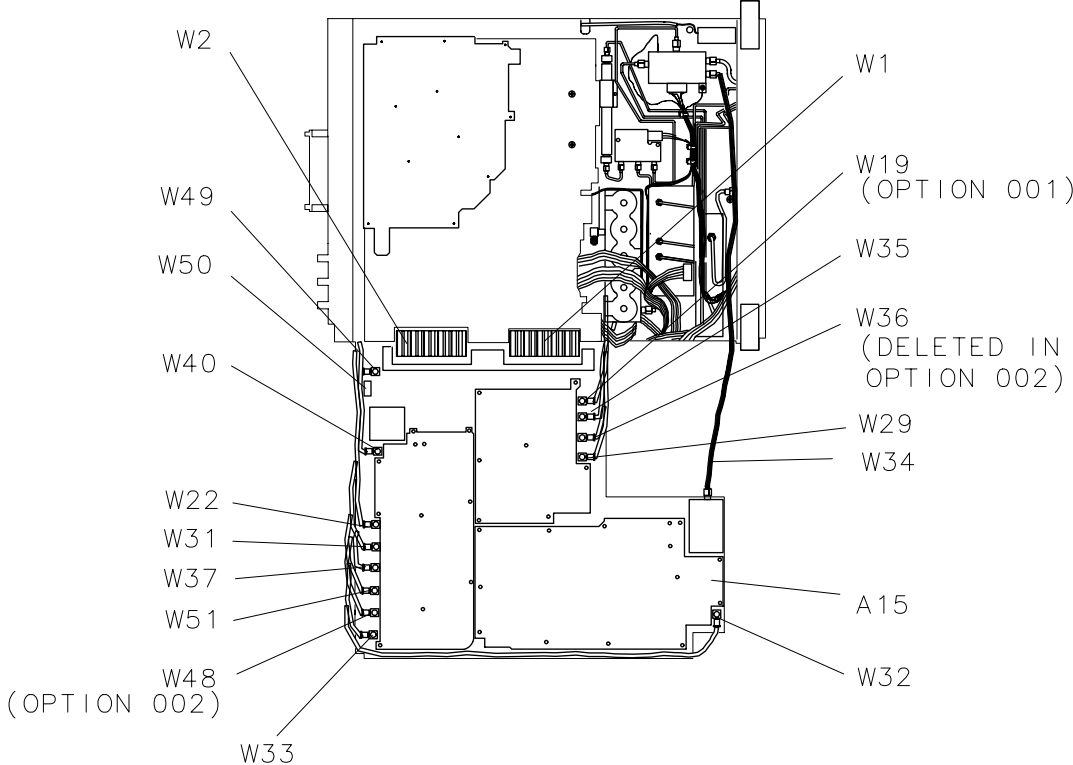
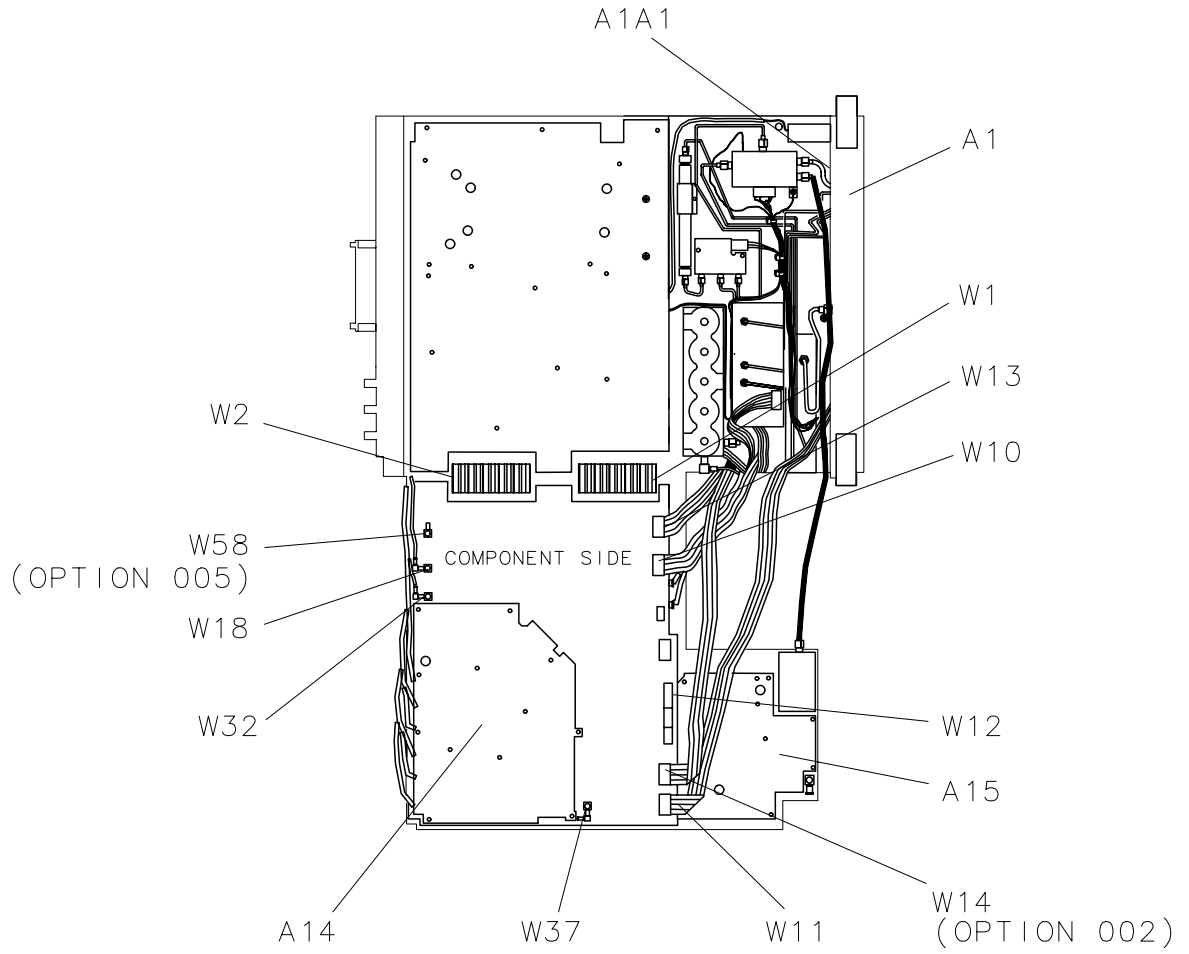

Figure 5-8 **Bottom View (A15 and A14 Unfolded)**



sj1133e

Figure 5-9 Front End

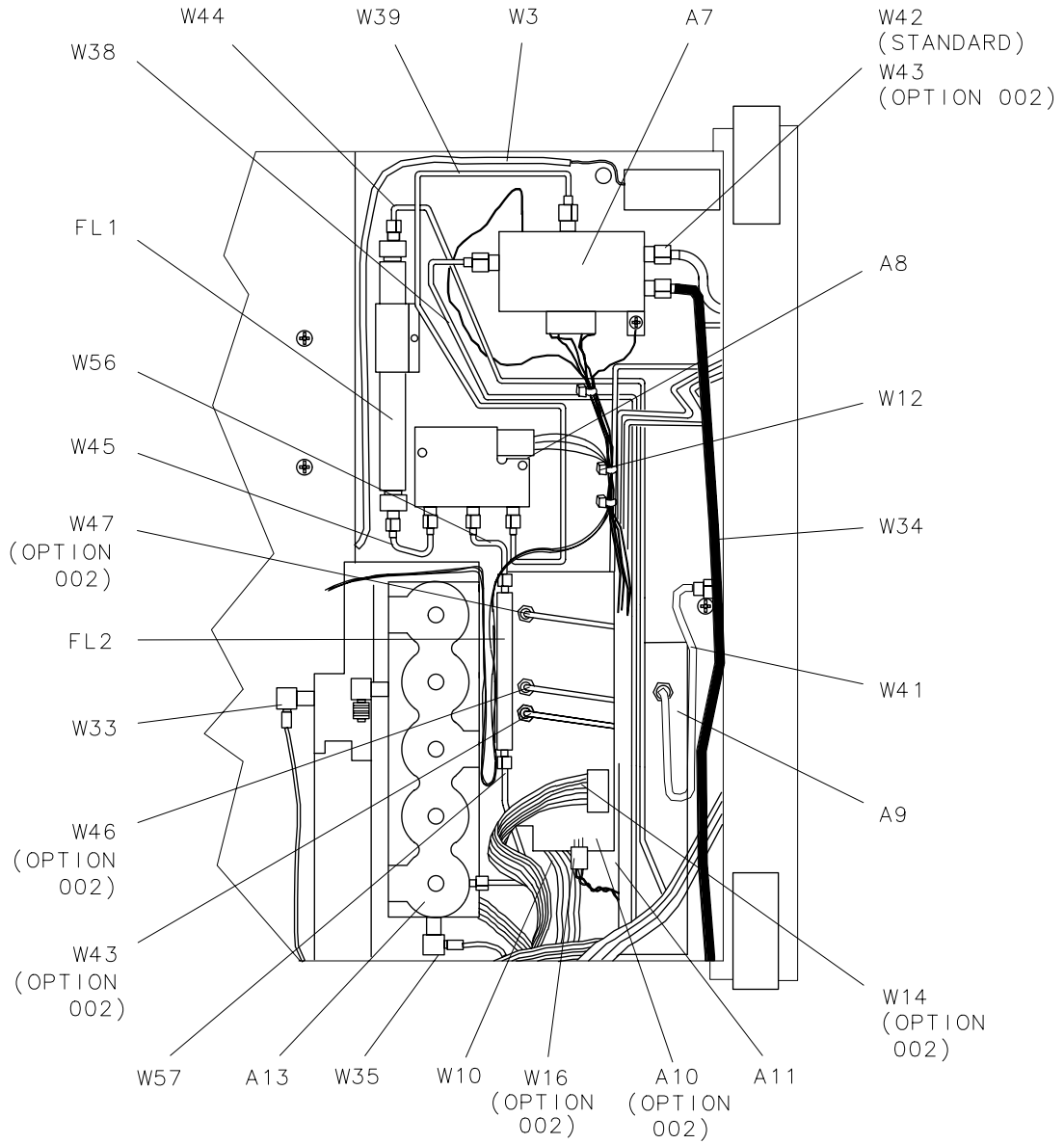
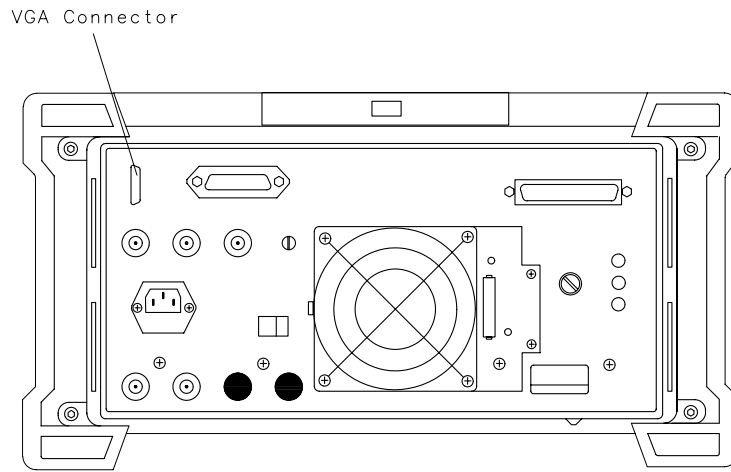
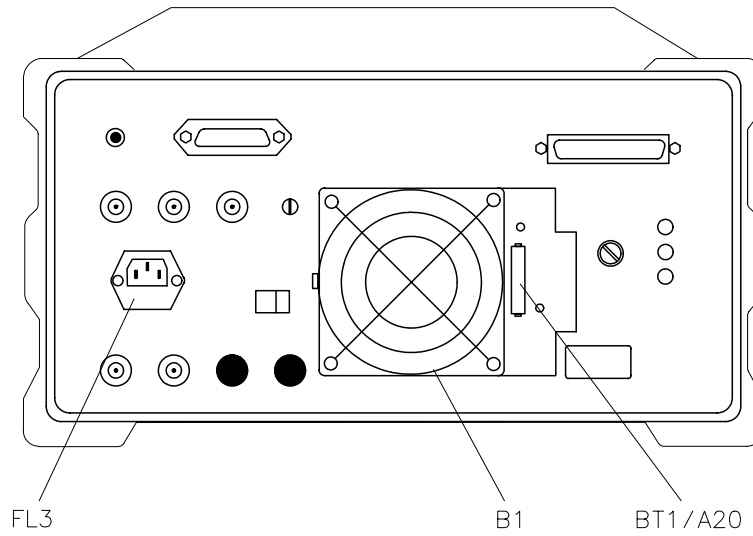

Figure 5-10 Rear View EC-Series



sj142c

Figure 5-11 Rear View E-Series



Major Assembly and Cable Locations
Introduction

6 **General Troubleshooting**

Introduction

This chapter provides information needed to troubleshoot the instrument to one of the six major functional sections. Chapters 7 through 12 cover troubleshooting for each of these sections. Before troubleshooting, read the rest of this introduction. To begin troubleshooting, refer to "Troubleshooting to a Functional Section" in this chapter.

| | |
|---|----------|
| Troubleshooting to a Functional Section | page 290 |
| Using the TAM | page 292 |
| Error Messages..... | page 298 |
| System Analyzer Programming Errors (100 to 150) | page 300 |
| Block Diagram Description..... | page 329 |

NOTE When a part or assembly is replaced, adjustment of the affected circuitry is usually required. Refer to Chapter 2, "Adjustment Procedures."

WARNING **Troubleshooting and repair of this instrument with the cover removed exposes high voltage points that may, if contacted, cause personal injury. Maintenance and repair of this instrument should, therefore, be performed only by a skilled person who knows the hazards involved. Where maintenance can be performed without power applied, the power should be removed. When any repair is completed, be sure that all safety features are intact and functioning and that all necessary parts are connected to their grounds.**

Assembly Level Text

To locate troubleshooting information for an individual assembly, refer to [Table 6-1 on page 291](#).

Block Diagrams

Instrument-level block diagrams are located at the end of this chapter. Power levels and voltages shown on block diagrams are provided as a troubleshooting aid only. They should not be used for making instrument adjustments.

Assembly Test Points

The spectrum analyzer board assemblies contain four types of test points: post, pad, extended component lead, and test jack. [Figure 6-1 on page 284](#) illustrates each type of test point as seen on both block

diagrams and circuit boards. The name of the test point will be etched into the circuit board next to the test point (for example, TP2). In some instances, the test point will be identified on the board by its number only.

Pad

Each pad test point uses a square pad and a round pad etched into the board assembly. The square pad is the point being measured. The round pad supplies a grounding point for the test probe.

Test Jack

The test jack is a collection of test points located on a 16-pin jack. There are over 26 test jacks used throughout the spectrum analyzer. The HP 85629B Test and Adjustment Module uses the spectrum analyzer test jacks during diagnostic and adjustment procedures. The pins on the test jack may be manually probed, provided caution is used to prevent accidental shorting between adjacent pins.

[Figure 6-1 on page 284](#) illustrates the pin configuration for the test jack. Line names are the same for all test jacks. The following mnemonics are used: MS "measured signal," TA "test and adjustment Module address line," and OS "output signal." Test jack test points are identified on block diagrams by both the jack/pin number and line name.

Ribbon Cables

Ribbon cables are used extensively in the spectrum analyzer. The following five cables use different pin numbering methods on the jacks (signal names remain the same but the pin numbers vary):

- W1, Power Cable
- W2, Control Cable
- W4, Option Cable
- A3W1, Interface Cable
- A19W1, HP-IB Cable

[Figure 6-2 on page 285](#) and [Figure 6-3 on page 286](#) illustrate the pin configurations of these five cables. Cables W1 and W2 use two pin numbering methods on their many jacks. These methods are identified in the interconnect and block diagrams by the letters "A" and "B" next to the jack designator (for example, J1(A)). Board assembly jacks connected to W1 will always be labeled J1. Board assembly jacks connected to W2 will always be labeled J2.

[Figure 6-4 on page 287](#) shows the pin configuration for the 80 pin, W60 cable that is found on EC-series instruments. The numbering of the pins is identical at J8 on the A2 Controller board and at J1 on the A17 Display Driver board.

Figure 6-1 Assembly Test Points

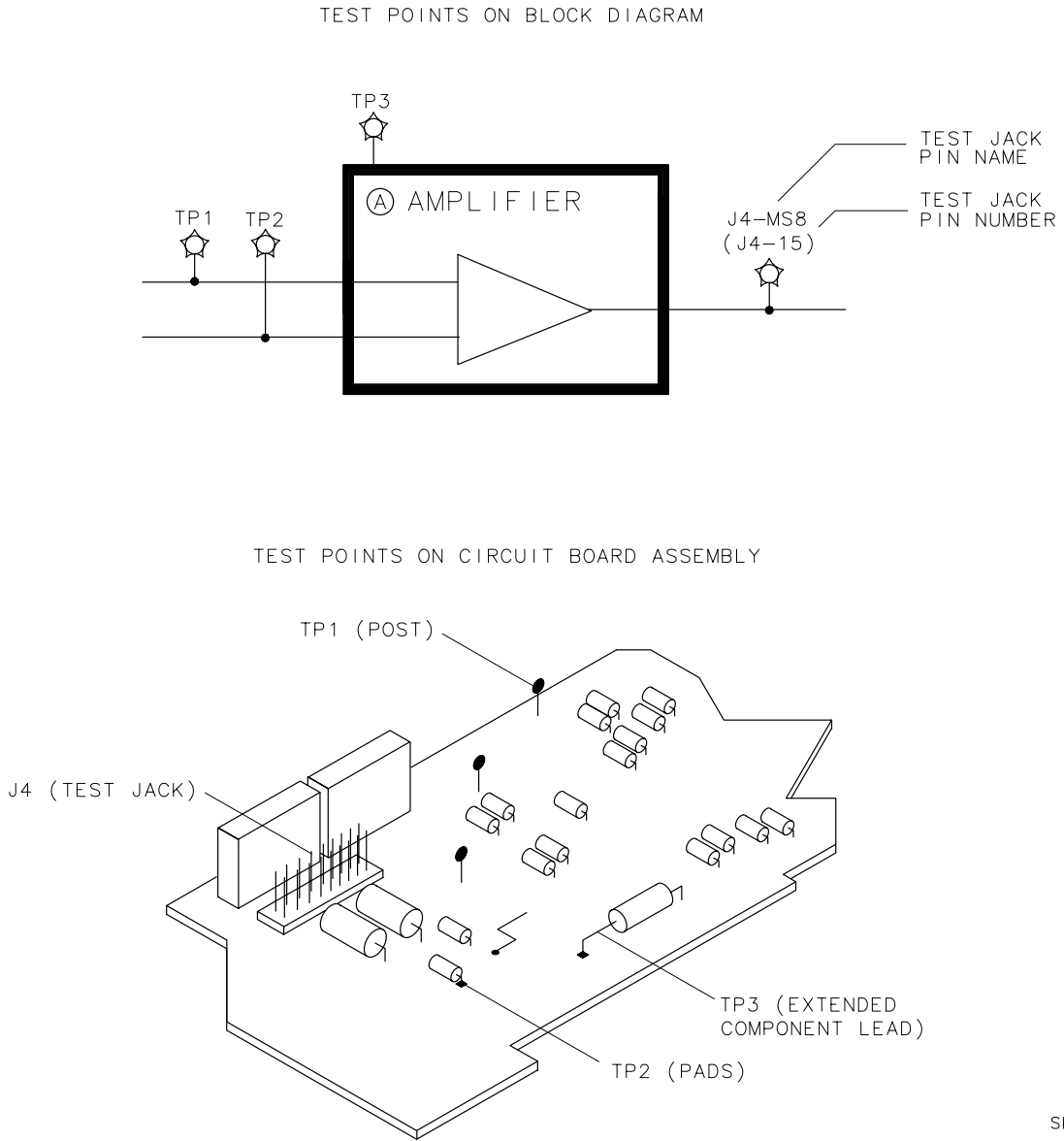
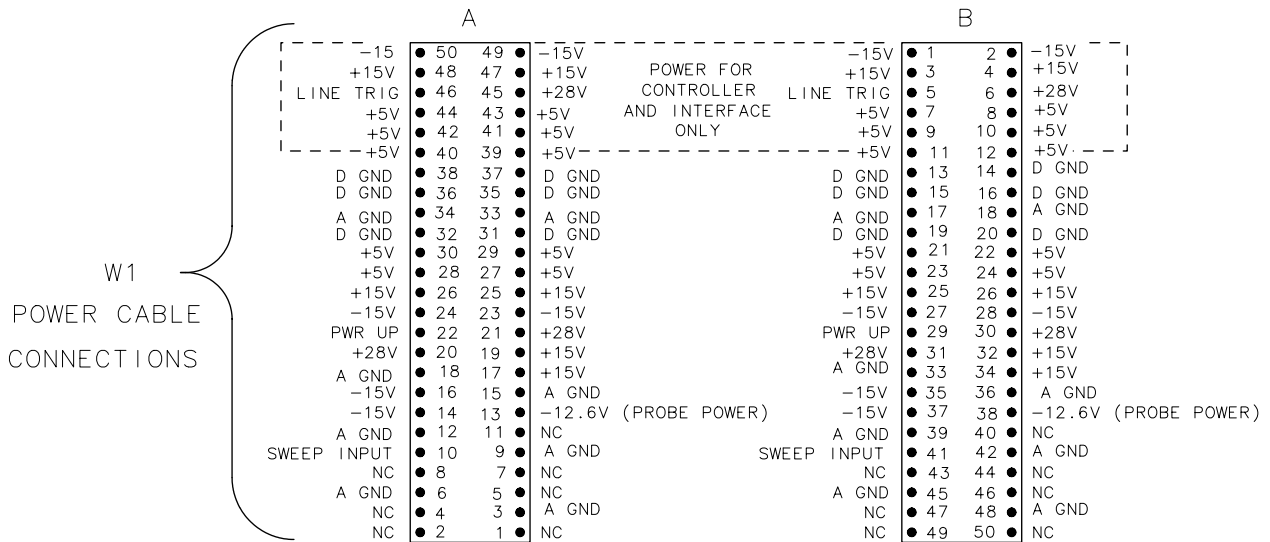
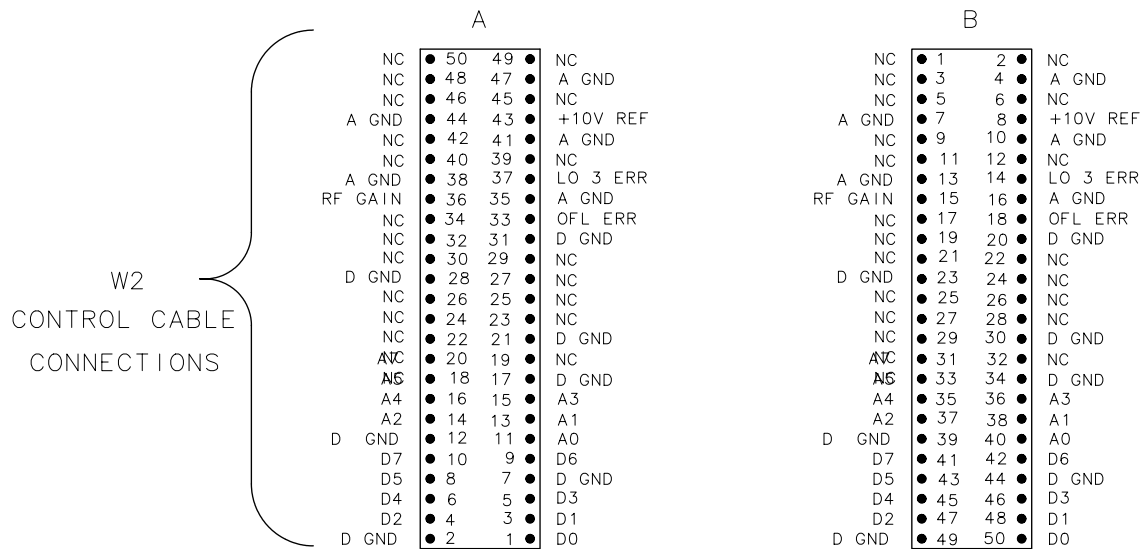

Figure 6-2 Ribbon Cable Connections (1 of 3)



*NOTE: Sweep Input for the Controller or Interface boards only.



sp149e

Figure 6-3 Ribbon Cable Connections (2 of 3)

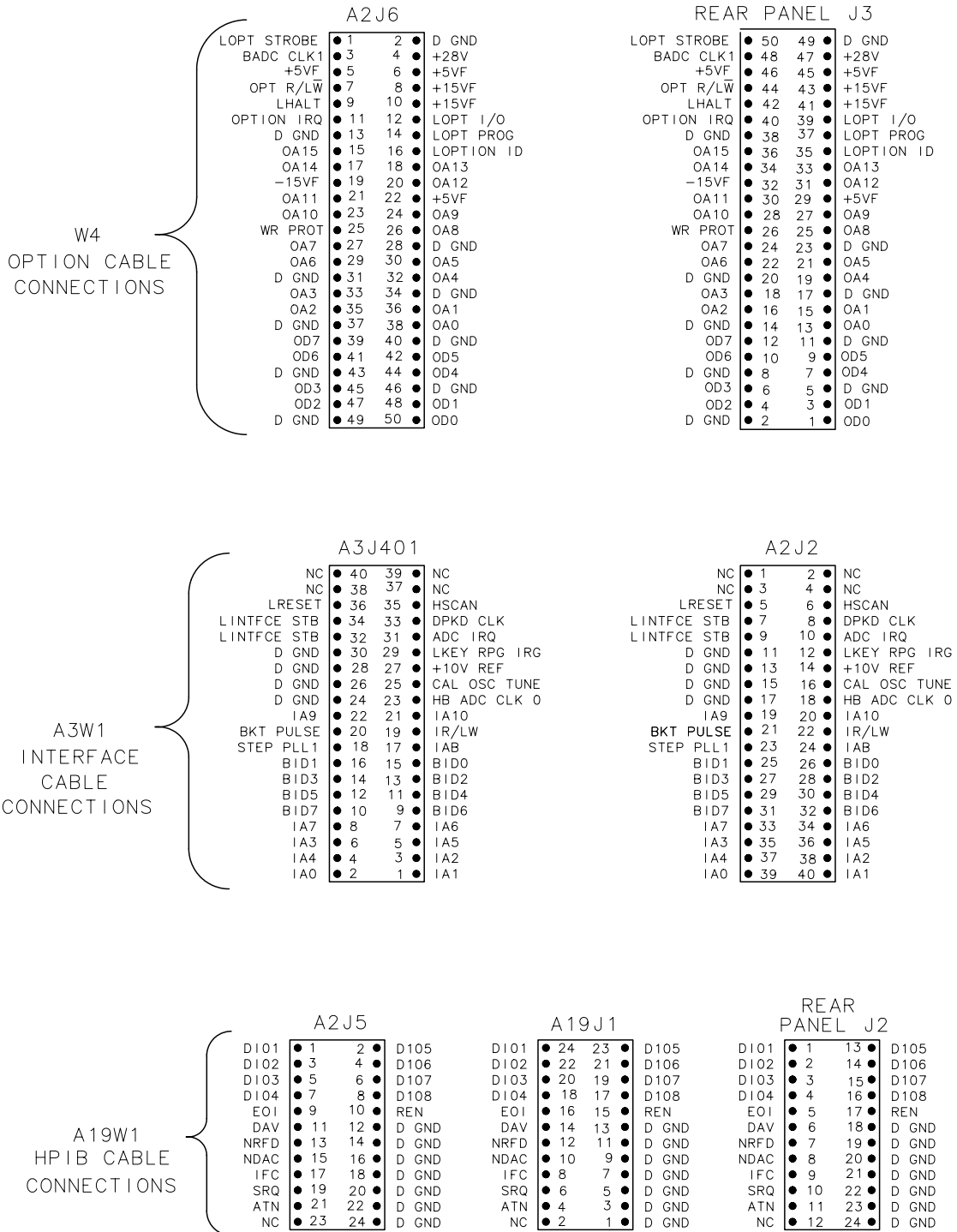

sp150e

Figure 6-4 Ribbon Cable Connections (3 of 3) - EC-Series Only

| | | | |
|-------------|------|------|-------------|
| GND SX | ● 80 | ● 79 | addrmsx2 |
| addrmsx 3 | ● 78 | ● 77 | GND SX |
| addrmsx 6 | ● 76 | ● 75 | addrmsx 7 |
| GND SX | ● 74 | ● 73 | addrmsx 10 |
| addrmsx 11 | ● 72 | ● 71 | GND SX |
| NC | ● 70 | ● 69 | NC |
| 6ND SX | ● 68 | ● 67 | NC |
| NC | ● 66 | ● 65 | GND SX |
| NC | ● 64 | ● 53 | NC |
| GND SX | ● 62 | ● 61 | DATAMSX 2 |
| DATAMSX 3 | ● 60 | ● 59 | GND SX |
| DATAMSX 6 | ● 58 | ● 57 | DATAMSX 7 |
| GND SX | ● 56 | ● 55 | DATAMSX 10 |
| DATAMSX11 | ● 54 | ● 53 | GNSD SX |
| DATAMSX 14 | ● 52 | ● 51 | DATAMSX 15 |
| GND SX | ● 50 | ● 49 | NC |
| _RESETMSX | ● 48 | ● 47 | GND SX |
| NC | ● 46 | ● 45 | +5V BKLT SX |
| +5VBKLT SX | ● 44 | ● 43 | +5VBKLT SX |
| +5VBLT SX | ● 42 | ● 41 | +5V SX |
| addrmsx 1 | ● 40 | ● 39 | GND SX |
| addrmsx 4 | ● 38 | ● 37 | addrmsx 5 |
| gnd sx | ● 36 | ● 35 | addrmsx 8 |
| addrmsx 9 | ● 34 | ● 33 | GND SX |
| addrmsx 12 | ● 32 | ● 31 | addrmsx 13 |
| GND SX | ● 30 | ● 29 | NC |
| NC | ● 28 | ● 27 | GND SX |
| NC | ● 26 | ● 25 | NC |
| GND SX | ● 24 | ● 23 | DATAMSX |
| DATAMSX 1 | ● 22 | ● 21 | GND SX |
| DATAMSX 4 | ● 20 | ● 19 | DATAMSX 5 |
| GND SX | ● 18 | ● 17 | DATAMSX 8 |
| DATAMSX 9 | ● 16 | ● 15 | GND SX |
| DATAMSX 12 | ● 14 | ● 13 | DATAMSX 13 |
| GND SX | ● 12 | ● 11 | LMUX-INSX |
| EN1SX | ● 10 | ● 9 | GND SX |
| NC | ● 8 | ● 7 | NC |
| GND SX | ● 6 | ● 5 | +5VBKLT SX |
| +5V BKLT SX | ● 4 | ● 3 | +5VBKLT SX |
| +5V BKLT SX | ● 2 | ● 1 | +5V SX |

sj114c

Figure 6-4 shows A2J8 connections on 8560 EC-Series Instruments. Lines 2 –5 and 42 – 44 supply +5V to the two LCD backlights. Lines 1 and 41 supply +5V to the A17A1 Inverter board. Lines 1 – 6 and 41 – 44 are identical on A17J1.

Service Cal Data Softkey Menus

The jumper on jack A2J12 is shipped from the factory in the WR PROT (write protect) position (jumper on pins 2 and 3). When the jumper is set to the WR ENA (write enable) position (jumper on pins 1 and 2), an additional service cal data menu is displayed under **CAL**. [Figure 6-5 on page 289](#) illustrates those areas of the service cal data menu that are available.

Figure 6-5 Service Cal Data Menu

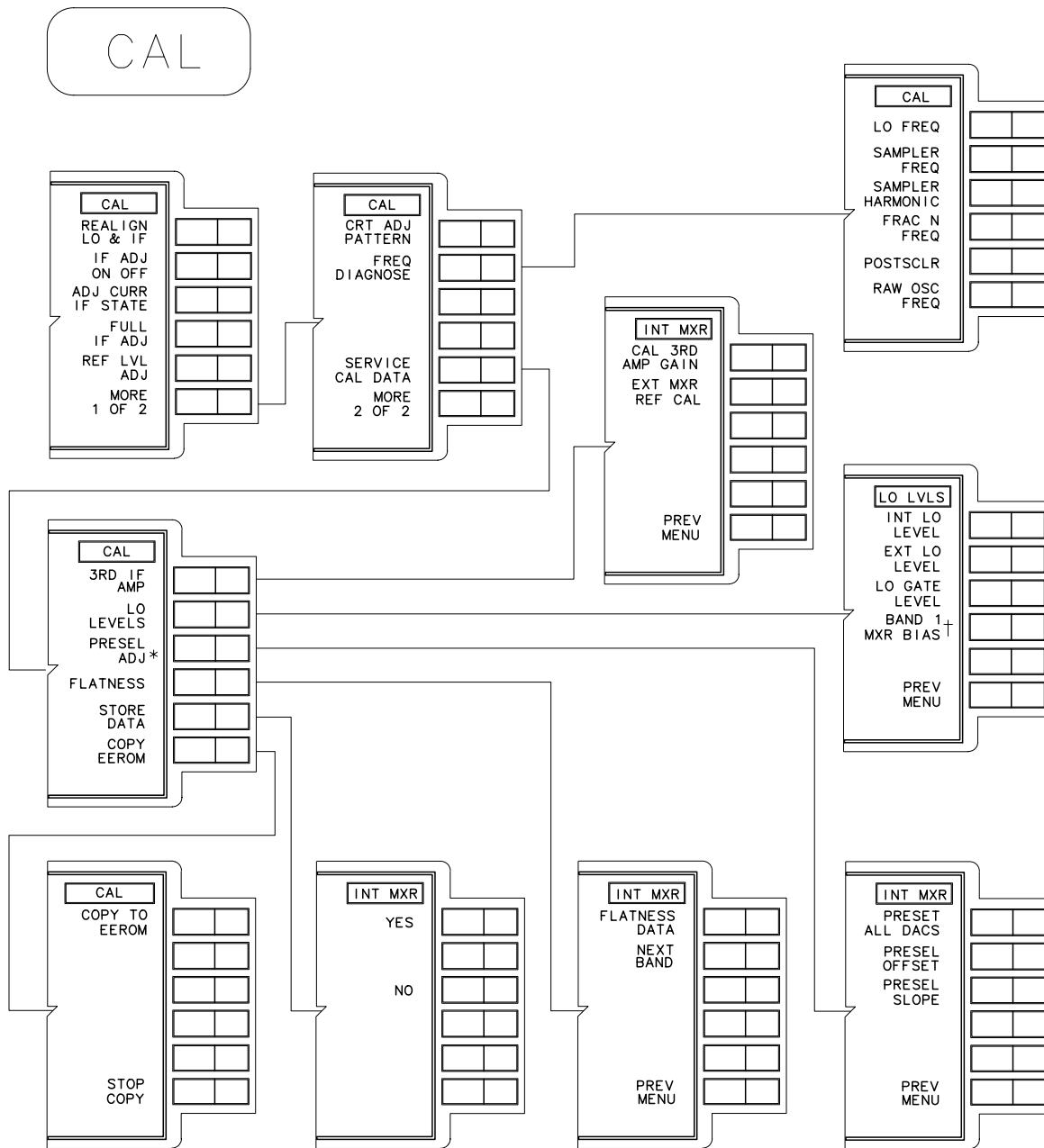

* PRESEL ADJ key and the associated menu apply to the HP8561E/HP8563E only.
† BAND 1 MXR BIAS key applies to HP8561E only.

sj143e

Troubleshooting to a Functional Section

1. Refer to [Table 6-1 on page 291](#) for the location of troubleshooting information.
2. If the HP 85629B Test and Adjustment Module (TAM) is available, refer to "Using the TAM" in this chapter for 8560E instruments.
3. If error messages are displayed, refer to "Error Messages" in this chapter. You will find both error descriptions and troubleshooting information.
4. If a signal cannot be seen, and no errors messages are displayed, the fault is probably in the RF section. Refer to Chapter 11, "RF Section."
5. Blank displays result from problems caused by either the controller or display/power-supply sections. Because error messages 700 to 755 caused by the controller section cannot be seen on a blank display, use the following BASIC program to read these errors over HP-IB. If the program returns an error code of 0, there are no errors.

```
10 DIM Err$(128)
20 OUTPUT 718;"ERR?;"
30 ENTER 718; Err$
40 PRINT Err$
50 END
```

- a. If there is no response over HP-IB, set an oscilloscope to the following settings:

Sweep time ms/div
Amplitude scale 1 V/div
 - b. The signals at A2J202 pin 3 and pin 14 should measure about 4 Vp-p. If the levels are incorrect, refer to Chapter 9 and troubleshoot the A2 controller assembly.
 - c. Set the oscilloscope to the following settings:

Sweep time 1 ms/div
Amplitude scale 2 V/div
 - d. The signal at A2J202 pin 15 should consist of TTL pulses. If the signal is at a constant level (high or low), troubleshoot the A2 controller assembly.
6. Display problems on 8560E instruments, such as intensity or distortion, are caused by either the controller or display/power supply sections. Refer to Chapter 9 or Chapter 12.

Table 6-1 Location of Assembly Troubleshooting Text

| Instrument Assembly | Location of Troubleshooting Text |
|---------------------------------|---|
| A1A1 keyboard | Chapter 7. ADC/Interface Section |
| A1A2 RPG | Chapter 7. ADC/Interface Section |
| A2 controller | Chapter 9. Controller Section |
| A3 interface | Chapter 7. ADC/Interface Section Chapter 8. IF Section |
| A4 log amplifier/cal oscillator | Chapter 8. IF Section |
| A5 IF | Chapter 8. IF Section |
| A6 power supply | Chapter 12. Display/Power Supply Section |
| A6A1 HV module | Chapter 12. Display/Power Supply Section |
| A7 1ST LO dist. ampl. | Chapter 10. Synthesizer Section |
| A8 low band mixer | Chapter 11. RF Section |
| A9 input attenuator | Chapter 11. RF Section |
| A10 tracking generator | Chapter 11. RF Section |
| A11 YTO | Chapter 10. Synthesizer Section |
| A13 2nd converter | Chapter 11. RF Section |
| A14 frequency control | Chapter 10. Synthesizer Section Chapter 11. RF Section |
| A15 RF assembly | Chapter 10. Synthesizer Section Chapter 11. RF Section |
| A17 LCD driver | Chapter 12. Display/Power Supply Section |
| A17 CRT driver | Chapter 12. Display/Power Supply Section |
| A18 LCD | Chapter 12. Display/Power Supply Section |
| A18 CRT | Chapter 12. Display/Power Supply Section |
| A19 HP-IB | Chapter 9. Controller Section |
| FL1,2 | Chapter 11. RF Section |

Using the TAM

When attached to the spectrum analyzer rear panel, the HP 85629B test and adjustment module (TAM) provides diagnostic functions for supporting the HP 8560E/EC. Because the TAM is connected directly to the internal data and address buses of the spectrum analyzer, it controls the spectrum analyzer hardware directly through firmware control. It would be impossible to control the hardware to the same extent either from the spectrum analyzer front panel or over the HP-IB.

Revision C (date code 890704), or later, of the HP 85629B TAM firmware supports the HP 8560E/EC spectrum analyzer.

The TAM measures voltages at key points in the circuitry and flags a failure whenever the voltage falls outside the limits. The TAM locates the failure to a small functional area which can be examined manually. Remember the following when using the TAM:

- Be sure the spectrum analyzer power is turned off when installing or removing the TAM.
- Use the **LP** softkey (found in all menus) for useful information.
- Pressing **MODULE** will return you to the main menu of the TAM.
- The TAM acts as the active controller on the HP-IB bus. No other active controller should be connected to the bus.

Diagnostic Functions

The TAM provides the three diagnostic functions listed below. (Additional menu selections support the TAM itself.) Refer to the following for a description of each function.

Diagnostic

1. Automatic Fault Isolation
2. Manual Probe Troubleshooting (*requires cover removal*)
3. Cal Oscillator Troubleshooting Mode (*requires cover removal*)

NOTE

The HP 85629B test and adjustment modules with firmware revision A or B will not properly execute automatic fault isolation on the HP 8560E/EC spectrum analyzer.

TAM Requirements

For the TAM to function properly, certain parts of the spectrum analyzer must be operating properly. These include the CPU, parts of the program ROM and program RAM, the keyboard and keyboard

interface, and the display.

Even though the TAM communicates to the operator via the display, some display problems can be troubleshot using the TAM. This is possible by using the **Print Page** softkey. Even if the display is dead, **Print Page** is still active. Refer to Chapter 12 for instructions on using the TAM when the display is not functioning.

Test Connectors

The TAM uses a built-in dc voltmeter and DAC to measure voltages on any one of the "test connectors" located throughout the HP 8560E/EC.

NOTE

HP 85629B test and adjustment modules with firmware revisions A or B cannot make valid measurements on test connector A14J16 on standard HP 8560E/EC spectrum analyzers, nor test connector A14J17 on HP 8560E/EC Option 002 spectrum analyzers.

Revision Connectors

One test connector on each assembly is reserved as a "revision connector." The TAM uses the revision connector to identify the design revision of the assembly. A "revision voltage" (placed onto one measured signal line, MSL, pin) indicates design changes.

The TAM must be plugged into the revision connector first to determine which tests to use for the assembly. If the revision connector has not been probed, a message will appear instructing you to connect the probe to the revision connector and press **TEST**. You can then probe the rest of the assembly connectors.

NOTE

If the revision of the PC board is newer than the TAM, a message will be displayed stating that the revision code for this board is not known by this module. The choices presented are to use the test for the latest known revision board, measure only voltages, or exit. In general, most points will not change from one board revision to another, so using the most current tests is still very useful. However, any failure should be verified using the manual troubleshooting procedures before doing a repair.

Inconsistent Results

Many of the signals measured by the TAM are digitally controlled. If inconsistent results are obtained, or if failures appear in unrelated areas, the digital control may be at fault. Refer to the manual troubleshooting procedures for those assemblies to isolate those failures.

Erroneous Results

If the TAM manual probe troubleshooting seems to be giving erroneous results, its performance can be checked by placing the probe on the TAM test connector (A2J11) located on the A2 controller assembly and executing the manual probe diagnostics. If either of the tests fail, the TAM is malfunctioning and should be serviced.

Blank Display (8560E only)

It is possible to use TAM manual probe troubleshooting without a display, if an HP-IB printer is available. Refer to Chapter 12 for more information.

Automatic Fault Isolation

Automatic fault isolation (AFI) is designed to isolate most faults to one or two assemblies. AFI can be run with the spectrum analyzer cover in place, and requires only the CAL OUTPUT signal as a stimulus. The entire procedure takes less than 2 minutes to complete if no failures are found.

AFI performs checks of five functional areas in a pre-defined sequence. The sequence minimizes the chance of making false assumptions. The TAM checks the spectrum analyzer "from the inside out." For example, the ADC is checked before the IF is checked. This ensures that if no signal is detected through the IF, the fault is in the IF section and not a faulty ADC. (The ADC measures the video signal from the IF section.)

The sequence of checks is as follows:

1. Controller check
2. ADC/interface check
3. IF/LOG check
4. LO control check
5. RF low band check

Display/Power Supply

AFI cannot check the display/power-supply section because this section powers the TAM and provides the display of AFI results.

Controller Check (8560E only)

The TAM performs a checksum of all ROMs, RAMs, and the EEROM. The CPU is also checked, since parts of the CPU could be nonfunctional while the TAM still operates. These checks are very similar to those done by the spectrum analyzer at power-on.

ADC/Interface Check

The keyboard interface and strobe-select circuitry must be functioning correctly, since these are required to operate the TAM. The TAM checks the ADC by attempting to measure three signals from three different locations. This ensures that an open or short in one cable will not hide the fact that the ADC is operating satisfactorily.

The analog bus (W2 control cable) is checked by sending data out on the data lines and reading the data back. If this check fails, disconnect one board at a time and rerun AFI to determine if an assembly causes the problem. If the fault remains with all assemblies disconnected from W2, troubleshoot W2 or the A3 interface assembly.

IF/LOG Check

The TAM uses the cal oscillator on the A4 assembly as the stimulus for checking the IF section. If the signal is undetected, the TAM repeats the test with a signal originating from the RF section. Presence of this signal through the IF indicates a faulty cal oscillator.

LO Control Check

The LO control check verifies test that all phase-lock loops (PLLs) in the synthesizer section lock. (Some oscillators are checked to ensure that they will lock outside their normal operating frequency range.) The TAM also performs an operational check on several DACs in the synthesizer section.

RF Check

The TAM tests the operation of A8 low band mixer, A9 input attenuator, second IF distribution, and most of the A13 second converter.

AFI also checks the flatness compensation amplifiers (part of the A15 RF assembly), ensuring that their gain can be adjusted over a certain range.

If no signal is detected through the RF section, AFI will substitute the 298 MHz SIG ID oscillator (Option 008 only) for the 3rd LO while simultaneously decreasing the 1st LO frequency by 2 MHz. If a signal can now be detected, troubleshoot the 3rd LO driver amplifier on the A15 RF assembly.

Manual Probe Troubleshooting

Manual probe troubleshooting probes the instrument test connectors to perform the following types of measurements:

- Amplifier and oscillator dc current draw by monitoring the voltage across a resistor of known value.
- Oscillator tune voltages ensuring proper operation of phase/frequency detectors and loop integrators.
- Static bias voltages.

NOTE

Unlike E-series instruments, EC-series instruments do not have a TAM connector on the A2 Controller board

If probing a connector for a check yields a "FAIL" indication, select the desired check using either the knob or step keys and press **More Info**. A description of the function checked (with measured and expected voltages/currents) is displayed with a list of additional areas to check. These areas can sometimes be checked by looking at another TAM connector, but usually require manual troubleshooting techniques to isolate the problem further. If an HP-IB printer is connected, press **Print Page** to provide a hard copy of the currently displayed screen (the softkey labels will not be printed).

Each test connector has fifteen pins (one pin is missing to act as a key). The pins contain eight measured signal lines (measured signal lines denoted as MS1 through MS8), one input signal line (OS1), one ground, and five pins encoding a five-bit connector address.

The TAM needs to probe the revision connector of each assembly once; subsequent readings are not necessary. It is possible, for example, to probe the A5 IF assembly, then the A4 log amplifier assembly, and then return to A5 without having to re-probe the A5 revision connector. However, the revision connector must be re-probed if the spectrum analyzer is returned to normal operation and then back to TAM control. (This is also true if the spectrum analyzer is turned off.)

Cal Oscillator Troubleshooting Mode

The cal oscillator troubleshooting mode enables front-panel control of the cal oscillator on the A4 assembly. The cal oscillator can be fixed-tuned to three different frequencies. The cal oscillator may also be set to one of four sweep widths, centered at 10.7 MHz.

Fixed-tuned settings:

11.5 MHz

10.7 MHz

9.9 MHz

Sweep-width settings:

20 kHz

10 kHz

4 kHz

2 kHz

The cal oscillator troubleshooting mode sends the cal oscillator output (–35 dBm) to the A5 IF assembly. On the A5 IF assembly all crystal filter poles are shorted, all LC poles enabled, and the 15 dB attenuator disabled. Signals from the RF section are attenuated as much as possible.

Error Messages

The spectrum analyzer displays error messages in the lower right-hand corner of the display. A number, or error code, is associated with each error message. These error messages alert the user to errors in spectrum analyzer function or use.

Multiple error messages may exist simultaneously. Refer to "Viewing Multiple Messages" below.

The following information can be found in this section:

- Viewing Multiple Messages
- Error Message Elimination
- System Analyzer Programming Errors (100 to 150)
- ADC Errors (200 to 299)
- LO and RF Hardware/Firmware Failures (300 to 399)
- YTO Loop Errors (300 to 301)
- Roller PLL Errors (302 to 316)
- YTO Loop Errors (317 to 318)
- Roller Oscillator Errors (321 to 329)
- YTO Loop Error (331)
- 600 MHz Reference Loop (333)
- YTO Leveling Loop (334)
- Sampling Oscillator (335)
- Span Accuracy Calibration Errors (356 to 361)
- 10 MHz Reference (336)
- Fractional N PLL (337)
- YTO Loop Settling Errors (351 to 354)
- Sampling Oscillator (355)
- Automatic IF Errors (400 to 599)
- System Errors (600 to 651)
- Digital and Checksum Errors (700 to 799)
- EEROM Checksum Errors (700 to 704)
- Program ROM Checksum Errors (705 to 710)
- RAM Check Errors (711 to 716)
- Microprocessor Error (717)
- Battery Problem (718)
- Model Number Error (719)
- System Errors (750 to 759)
- Fast ADC Error (760)
- Option Module Errors (800 to 899)
- User Generated Errors (900 to 999)

Viewing Multiple Messages

Although multiple errors may exist, the spectrum analyzer displays only one error message at a time. To view any additional messages, do the following:

1. Press **RECALL** and **MORE 1 OF 2**.
2. Press **RECALL ERRORS**. An error message is displayed in the active function block.
3. Use the up and down step keys to scroll through any other error messages which might exist, making note of each error code.

Error Message Elimination

When an error message is displayed, always perform the following procedure:

1. Press **SAVE** and **SAVE STATE**.
2. Store the current state in a convenient STATE register. (It may be necessary to set **SAVELOCK** to OFF.)
3. Press **CAL** and **REALIGN LO &IF**. Wait for the sequence to finish.
4. Press **RECALL** and **RECALL STATE**.
5. Recall the previously stored STATE.
6. If an error message is still displayed, refer to the list of error messages below for an explanation of the error messages.

System Analyzer Programming Errors (100 to 150)

Refer to the *HP 8560 E-Series and EC-Series Spectrum Analyzers User's Guide* for information on programming the spectrum analyzer.

- 100 NO PWRON Power-on state is invalid; default state is loaded. Press **SAVE, PWR ON STATE** to clear error message.
- 101 NO STATE State to be RECALLED not valid or not SAVED.
- 106 ABORTED! Current operation is aborted; HP-IB parser reset.
- 107 HELLO ?? No HP-IB listener is present.
- 108 TIME OUT Analyzer timed out when acting as controller.
- 109 CtrlFail Analyzer unable to take control of the bus.
- 110 NOT CTRL Analyzer is not system controller.
- 111 # ARGMTS Command does not have enough arguments.
- 112 ??CMD?? Unrecognized command.
- 113 FREQ NO! Command cannot have frequency units.
- 114 TIME NO! Command cannot have time units.
- 115 AMPL NO! Command cannot have amplitude units.
- 116 ?UNITS?? Unrecognizable units.
- 117 NOP NUM Command cannot have numeric units.
- 118 NOP EP Enable parameter cannot be used.
- 119 NOP UPDN UP/DN are not valid arguments for this command.
- 120 NOP ONOF ON/OFF are not valid arguments for this command.
- 121 NOP ARG AUTO/MAN are not valid arguments for this command.
- 122 NOP TRC Trace registers are not valid for this command.
- 123 NOP ABLK A-block format not valid here.
- 124 NOP IBLK I-block format not valid here.
- 125 NOP STRNG Strings are not valid for this command.
- 126 NO ? This command cannot be queried.
- 127 BAD DTMD Not a valid peak detector mode.
- 128 PK WHAT? Not a valid peak search parameter.
- 129 PRE TERM Premature A-block termination.

- 130 BAD TDF Arguments are only for TDF command.
- 131 ?? AM/FM AM/FM are not valid arguments for this command.
- 132 !FAV/RMP FAV/RAMP are not valid arguments for this command.
- 133 !INT/EXT INT/EXT are not valid arguments for this command.
- 134 ??? ZERO ZERO is not a valid argument for this command.
- 135 ??? CURR CURR is not a valid argument for this command.
- 136 ??? FULL FULL is not a valid argument for this command.
- 137 ??? LAST LAST is not a valid argument for this command.
- 138 !GRT/DSP GRT/DSP are not valid arguments for this command.
- 139 PLOTONLY Argument can only be used with PLOT command.
- 140 ?? PWRON PWRON is not a valid argument for this command.
- 141 BAD ARG Argument can only be used with FDIAG command.
- 142 BAD ARG Query expected for FDIAG command.
- 143 NO PRESL No preselector hardware to use command with.
- 144 COUPL?? Invalid COUPLING argument, expected AC or DC.

ADC Errors (200 to 299)

These errors are directly related to the ADC/interface section. Suspect a faulty A2 controller, A3 interface assembly or, in 8560 E-series analyzers, the A16 fast ADC (FADC) assembly (Option 007).

Errors 202 through 207 apply only to EC-series analyzers and E-series analyzers with fast ADC (Option 007).

- 200 SYSTEM ADC driver/ADC hardware/firmware interaction; check for other errors.
- 201 SYSTEM ADC controller/ADC hardware/firmware interaction; check for other errors.
- 202 FADC CAL Binary search failed during FADC linear offset calibration.

This error applies only to EC-series analyzers and E-series analyzers with fast ADC (Option 007)

- 203 FADC CAL Binary search failed during FADC log offset calibration.

This error applies only to EC-series analyzers and E-series analyzers with fast ADC (Option 007)

204 FADC CAL Binary search failed during FADC log expand offset calibration.

This error applies only to EC-series analyzers and E-series analyzers with fast ADC (Option 007).

205 FADC CAL Slope derivation failed during FADC linear offset calibration.

This error applies only to EC-series analyzers and E-series analyzers with fast ADC (Option 007).

206 FADC CAL Slope derivation failed during FADC log offset calibration.

This error applies only to EC-series analyzers and E-series analyzers with fast ADC (Option 007)

207 FADC CAL Slope derivation failed during FADC log expand offset calibration.

This error applies only to EC-series analyzers and E-series analyzers with fast ADC (Option 007)

250 OUTOF RG ADC input is outside of ADC range.

251 NO IRQ Microprocessor not receiving interrupt from ADC.

LO and RF Hardware/Firmware Failures (300 to 399)

YTO Loop Errors (300 to 301)

These errors often require troubleshooting the A14 frequency control assembly (synthesizer section) or the ADC circuits.

300 YTO UNLK YTO (first LO) phase locked loop is unlocked. The ADC measures YTO_ERR voltage under phase-lock condition.

301 YTO UNLK YTO (first LO) phase locked loop is unlocked. Same as ERR 300 except ERR 301 is set if the voltage is outside certain limits.

Roller PLL Errors (302 to 316)

These errors indicate a faulty roller oscillator on the A14 frequency control assembly. Refer to Chapter 10. The A3 interface ADC circuits may also be faulty. If error codes 333 and 499 are present, suspect the 10 MHz reference, the A21 OCXO, or on the A15 assembly (Option 103). These errors do not apply to the hardware in an HP 8560 E-series or EC-series spectrum analyzer. If they occur in an HP 8560 E-series or EC-series spectrum analyzer, suspect a problem with the model

number identification in the spectrum analyzer firmware.

- 302 OFF UNLK Offset roller oscillator PLL is unlocked. May indicate loss of 10 MHz reference. The 10 MHz reference should measure greater than -7 dBm at A15J303. The ADC measures OFFSENSE at the beginning of each sweep and, if the voltage is outside certain limits, the offset oscillator pretuned DAC is adjusted to bring OFFSENSE within the proper range. ERR 302 is set if this cannot be accomplished. This error is not applicable to HP 8560 E-series or EC-series spectrum analyzers. If it occurs in an HP 8560 E-Series spectrum analyzer, suspect a problem with the model number identification in the spectrum analyzer firmware.
- 303 XFR UNLK Transfer roller oscillator PLL is unlocked. May indicate loss of 10 MHz reference. The 10 MHz reference should measure greater than -7 dBm at A15J303. The ADC measures XFRSENSE at the beginning of each sweep and, if the voltage is outside certain limits, the transfer oscillator pretuned DAC is adjusted to bring XFRSENSE within the proper range. ERR 303 is set if this cannot be accomplished. This error is not applicable to HP 8560 E-series or EC-series spectrum analyzers. If it occurs in an HP 8560 E-series or EC-series spectrum analyzer, suspect a problem with the model number identification in the spectrum analyzer firmware.
- 304 ROL UNLK Main roller oscillator PLL is unlocked. May indicate loss of 10 MHz reference. The 10 MHz reference should measure greater than -7 dBm at A15J303. The ADC measures MAINSENSE at the beginning of each sweep and, if the voltage is outside certain limits, the main roller pretune DAC is adjusted to bring OFFSENSE within the proper range. ERR 304 is set if this cannot be accomplished. This error is not applicable to HP 8560 E-series or EC-series spectrum analyzers. If it occurs in an HP 8560 E-series or EC-series spectrum analyzer, suspect a problem with the model number identification in the spectrum analyzer firmware.
- 305 FREQ ACC Unable to adjust MAINSENSE close to 0 volts using the coarse adjust DAC. The coarse adjust and fine adjust DAC are used together to set MAINSENSE to 0 volts with the loop opened. ERR 305 is set if the coarse adjust DAC cannot bring MAINSENSE close enough to 0 volts for the fine adjust DAC to bring MAINSENSE to exactly 0 volts. This error is not applicable to HP 8560 E-series or EC-series spectrum analyzers. If it occurs in

an HP 8560 E-series or EC-series spectrum analyzer, suspect a problem with the model number identification in the spectrum analyzer firmware.

- 306 **FREQ ACC** Unable to adjust MAINSENSE to 0 volts using the fine adjust DAC. The coarse adjust and fine adjust DAC are used together to set MAINSENSE to 0 volts with the loop opened. ERR 306 is set if the fine adjust DAC cannot bring MAINSENSE to 0 volts. This error is not applicable to HP 8560 E-series or EC-series spectrum analyzers. If it occurs in an HP 8560 E-series or EC-series spectrum analyzer, suspect a problem with the model number identification in the spectrum analyzer firmware.
- 307 **FREQ ACC** Transfer oscillator pretuned DAC out of range. The transfer oscillator pretune procedure attempts to find pretuned DAC values by programming the PLL to 25 different frequencies and incrementing the transfer oscillator pretune DAC until XFRSENSE changes polarity. ERR 307 is set if the DAC is set to 255 (maximum) before XFRSENSE changes polarity. This error is not applicable to HP 8560 E-series or EC-series spectrum analyzers. If it occurs in an HP 8560 E-series or EC-series spectrum analyzer, suspect a problem with the model number identification in the spectrum analyzer firmware.
- 308 **FREQ ACC** Offset oscillator pretune DAC not within prescribed limits at low frequency. The offset oscillator pretune DAC is set to provide a frequency less than 189 MHz while the PLL is programmed for 189 MHz. ERR 308 is set if XFRSENSE is greater than +5 V (it should be at the negative rail). This error is not applicable to HP 8560 E-series or EC-series spectrum analyzers. If it occurs in an HP 8560 E-series or EC-series spectrum analyzer, suspect a problem with the model number identification in the spectrum analyzer firmware.

- 309 **FREQ ACC** Offset oscillator pretune DAC not within prescribed limits at high frequency. The offset oscillator pretune DAC is set to provide a frequency less than 204 MHz while the PLL is programmed for 204 MHz. ERR 309 is set if XFRSENSE is greater than +5 V (it should be at the negative rail). This error is not applicable to HP 8560 E-series or EC-series spectrum analyzers. If it occurs in an HP 8560 E-series or EC-series spectrum analyzer, suspect a problem with the model number identification in the spectrum analyzer firmware.
- 310 **FREQ ACC** Main roller pretune DAC set to 255. The main roller pretune DAC is set to 5, causing MAINSENSE to go to the positive rail. The DAC is incremented until MAINSENSE changes polarity. ERR 310 is set if the DAC is set to 255 before MAINSENSE changes to a negative polarity. This error is not applicable to HP 8560 E-series or EC-series spectrum analyzers. If it occurs in an HP 8560 E-series or EC-series spectrum analyzer, suspect a problem with the model number identification in the spectrum analyzer firmware.
- 311 **FREQ ACC** Main roller pretune DAC set to 255. The main roller pretune DAC is set to 5, causing MAINSENSE to go to the positive rail. The DAC is incremented until MAINSENSE changes polarity. ERR 311 is set if the DAC is set to 255 before MAINSENSE changes to a negative polarity. This error is not applicable to HP 8560 E-series or EC-series spectrum analyzers. If it occurs in an HP 8560 E-series or EC-series spectrum analyzer, suspect a problem with the model number identification in the spectrum analyzer firmware.
- 312 **FREQ ACC** Unable to adjust MAINSENSE to 0 volts using the fine adjust DAC. The coarse adjust and fine adjust DAC are used together to set MAINSENSE to 0 volts with the loop opened. ERR 312 is set if the fine adjust DAC cannot bring MAINSENSE to 0 volts. This error is not applicable to HP 8560 E-series or EC-series spectrum analyzers. If it occurs in an HP 8560 E-series or EC-series spectrum analyzer, suspect a problem with the model number identification in the spectrum analyzer firmware.
- 313 **FREQ ACC** Error in LO synthesis algorithm. ERR 313 is set if a combination of sampler oscillator and roller oscillator frequencies could not be found to correspond to the required YTO start frequency. Contact the factory. This error is not applicable to HP 8560 E-series or EC-series spectrum analyzers. If it occurs in an HP 8560 E-series or EC-series spectrum analyzer, suspect a problem with

the model number identification in the spectrum analyzer firmware.

- 314 **FREQ ACC** Indicates problems in the span calibration. Troubleshoot any unlocks before attempting to troubleshoot span calibration problems, because the loops must all lock in order to perform the calibration. If LO spans greater than 1 MHz are correct, check A14U114B, A14U115A, A14U116, or A14Q101. This error message appears when the main roller oscillator sweep sensitivity is 0. A sweep ramp is injected into the locked main roller loop which should generate a negative-going ramp on MAINSENSE. ERR 314 is set if the slope of this ramp is 0. This is an indication of an unlocked main roller loop or lack of a sweep ramp. This error is not applicable to HP 8560 E-series or EC-series spectrum analyzers. If it occurs in an HP 8560 E-series or EC-series spectrum analyzer, suspect a problem with the model number identification in the spectrum analyzer firmware.
- 315 **FREQ ACC** Indicates problems in the span calibration. Troubleshoot any unlocks before attempting to troubleshoot span calibration problems, because the loops must all lock in order to perform the calibration. If LO spans greater than 1 MHz are correct, check A14U114B, A14U115A, A14U116, or A14Q101. This error message appears when the roller span attenuator DAC is out of range. This DAC value is recalculated each time there are changes to the span or start frequency. ERR 315 is set if this value is less than 10 or greater than 245. This error is not applicable to HP 8560 E-series or EC-series spectrum analyzers. If it occurs in an HP 8560 E-series or EC-series spectrum analyzer, suspect a problem with the model number identification in the spectrum analyzer firmware.
- 316 **FREQ ACC** Sensitivity of main roller pretune DAC is 0. Once the main roller is locked, the MAINSENSE voltage is measured and the pretune DAC value is incremented by two. ERR 316 is set if the difference between the new MAINSENSE voltage and the previous MAINSENSE voltage is 0. This error is not applicable to HP 8560 E-series or EC-series spectrum analyzers. If it occurs in an HP 8560 E-series or EC-series spectrum analyzer, suspect a problem with the model number identification in the spectrum analyzer firmware.

YTO Loop Errors (317 to 318)

These messages indicate that the YTO main coil coarse DAC (ERR 317) or fine DAC (ERR 318) is at its limit. If error codes 300 or 301 are not present, a hardware problem exists in the YTO loop but the loop can still acquire lock. Refer to Chapter 10 to troubleshoot the YTO PLL. The ADC circuit on the A3 interface assembly may also cause this error.

- 317 FREQ ACC Main coil coarse DAC at limit. The main coil coarse DAC is set to bring YTO ERR close enough to 0 volts for the main coil fine DAC to bring YTO ERR to exactly 0 volts. ERR 317 is set if the main coil coarse DAC is set to one of its limits before bringing YTO ERR close enough to 0 volts.
- 318 FREQ ACC Main coil fine DAC at limit. The main coil fine DAC is set to bring YTO ERR to 0 volts after the main coil coarse DAC has brought YTO ERR close to 0 volts. ERR 318 is set if the main coil fine DAC is set to one of its limits before bringing YTO ERR to 0 volts.
- 319 WARN COA The YTO coarse tune DAC is near its limits.
- 320 WARN FIN The YTO fine tune DAC is near its limits.

Roller Oscillator Errors (321 to 329)

These errors indicate a faulty roller oscillator on the A14 frequency control assembly. Refer to Chapter 10. The A3 interface ADC circuits may also be faulty. If error codes 333 and 499 are also present, suspect the 10 MHz reference, the A21 OCXO, or the A15 assembly (Option 103). These errors do not apply to the hardware in an HP 8560 E-series or EC-series spectrum analyzer. If they occur in an HP 8560 E-series or EC-series spectrum analyzer, suspect a problem with the model number identification in the spectrum analyzer firmware.

- 321 FREQ ACC Main roller tuning sensitivity is not greater than 0. The MAINSENSE voltage is noted in a locked condition and the main roller is programmed to a frequency 400 kHz higher. ERR 321 is set if the new MAINSENSE voltage is not greater than the previous MAINSENSE voltage. This error is not applicable to HP 8560 E-series or EC-series spectrum analyzers. If it occurs in an HP 8560 E-series or EC-series spectrum analyzer, suspect a problem with the model number identification in the spectrum analyzer firmware.
- 322 FREQ ACC Main roller pretune DAC value set greater than 255.

During the LO adjust sequence, the main roller is locked and then programmed to a frequency 1.6 MHz higher. A new pretune DAC value is calculated based upon the main roller tuning sensitivity. ERR 322 is set if this calculated value is greater than 255. This error is not applicable to HP 8560 E-series or EC-series spectrum analyzers. If it occurs in an HP 8560 E-series or EC-series spectrum analyzer, suspect a problem with the model number identification in the spectrum analyzer firmware.

- 324 **FREQ ACC** Unable to adjust MAINSENSE close to 0 volts using the coarse adjust DAC. The coarse adjust and fine adjust DAC are used together to set MAINSENSE to 0 volts with the loop opened. ERR 324 is set if the coarse adjust DAC cannot bring MAINSENSE close enough to 0 volts for the fine adjust DACs to bring MAINSENSE to exactly 0 volts. This error is not applicable to HP 8560 E-series or EC-series spectrum analyzers. If it occurs in an HP 8560 E-series or EC-series HP 8560 E-series or EC-series spectrum analyzer, suspect a problem with the model number identification in the spectrum analyzer firmware.
- 325 **FREQ ACC** Unable to adjust MAINSENSE to 0 volts using the fine adjust DAC. The coarse adjust and fine adjust DAC are used together to set MAINSENSE to 0 volts with the loop opened. ERR 325 is set if the fine adjust DAC cannot bring MAINSENSE to 0 volts. This error is not applicable to HP 8560 E-series or EC-series spectrum analyzers. If it occurs in an HP 8560 E-series or EC-series spectrum analyzer, suspect a problem with the model number identification in the spectrum analyzer firmware.
- 326 **FREQ ACC** Fine adjust DAC near end of range. The fine adjust DAC is set to bring MAINSENSE to 0 volts. ERR 326 is set if the fine adjust DAC value is set to less than 5 or greater than 250. This error is not applicable to HP 8560 E-series or EC-series spectrum analyzers. If it occurs in an HP 8560 E-series or EC-series spectrum analyzer, suspect a problem with the model number identification in the spectrum analyzer firmware.
- 327 **OFF UNLK** Offset roller oscillator PLL is unlocked. May indicate loss of 10 MHz reference. The 10 MHz reference should measure greater than -7 dBm at A15J303. The ADC measures OFFSENSE at the beginning of each sweep and, if the voltage is outside certain limits, the offset oscillator pretune DAC is adjusted to bring OFFSENSE within the proper range. ERR 327 is set if this cannot

be accomplished. This error is not applicable to HP 8560 E-series or EC-series spectrum analyzers. If it occurs in an HP 8560 E-series or EC-series spectrum analyzer, suspect a problem with the model number identification in the spectrum analyzer firmware.

328 FREQ ACC Roller fine adjust DAC sensitivity less than or equal to 0. During the LO adjust routine, the fine adjust DAC is set to two different values and the MAINSENSE voltage is measured at each setting. ERR 328 is set if the difference between these voltages is 0 or negative. This is typically because the main roller loop is unlocked. This error is not applicable to HP 8560 E-series or EC-series spectrum analyzers. If it occurs in an HP 8560 E-series or EC-series spectrum analyzer, suspect a problem with the model number identification in the spectrum analyzer firmware.

329 FREQ ACC Roller coarse adjust DAC sensitivity less than or equal to 0. During the LO adjust routine, the coarse adjust DAC is set to two different values and the MAINSENSE voltage is measured at each setting. ERR 329 is set if the difference between these voltages is 0 or negative. This is typically because the main roller loop is unlocked. This error is not applicable to HP 8560 E-series or EC-series spectrum analyzers. If it occurs in an HP 8560 E-series or EC-series spectrum analyzer, suspect a problem with the model number identification in the spectrum analyzer firmware.

YTO Loop Error (331)

This error rarely occurs but is usually indicative of a digital hardware failure.

331 FREQ ACC Invalid YTO frequency. Firmware attempted to set the YTO to a frequency outside the range of the YTO (2.95 to 6.8107 GHz). Suspect a digital hardware problem, such as a bad RAM on the A2 controller assembly. Contact the factory.

600 MHz Reference Loop (333)

This error requires troubleshooting the A14 frequency control assembly (synthesizer section) or the ADC circuits.

333 600 UNLK The 600 MHz reference oscillator PLL is unlocked. If error codes 302, 303, 304, 327 or 499 are also present, suspect the 10 MHz reference, the A21 OCXO, or the TCXO on Option 103, or the A15 RF assembly. ERR 333 is set if LO3ERR is outside of its prescribed limits.

YTO Leveling Loop (334)

This error often requires troubleshooting the A14 frequency control assembly or A7 LODA (synthesizer section) or the ADC circuits.

- 334 LO AMPL 1ST LO distribution amplifier is unlevelled. Error 334 may be displayed if the front-panel LO OUTPUT is not terminated into 50 ohms. This error is usually accompanied by error codes 300 or 301. ERR 301 YTO UNLK is cleared once ERR 334 has been cleared. Check the output of the A11 YTO with the jumper on A14J23 in the TEST position. The YTO power output should be between +9 and +13 dBm. If the YTO is working properly, refer to "A7 LODA Drive" in Chapter 10. The LODA AGC voltage is monitored by the ADC. ERR 334 is set if LODA AGC is outside of its prescribed limits. Refer to "A7 LODA Drive" in Chapter 11.

Sampling Oscillator (335)

This error indicates an unlocked sampling oscillator (also known as the offset lock loop).

- 335 SMP UNLK Sampling oscillator PLL is unlocked. ERR 335 is set if OFL_ERR is outside its prescribed limits.

10 MHz Reference (336)

This message occurs during the internal IF calibration routines. The routine locks the cal oscillator to the internal 10 MHz reference, regardless of the setting of INT/EXT REF.

- 336 10 MHz Ref Calibration oscillator failed to lock within 5 seconds after going to internal 10 MHz reference. ERR 336 will not be cleared until a successful full cal "LO Re-Align" is executed.

Fractional N PLL (337)

This error indicates an unlocked fractional N phase locked loop. This error only applies to the hardware in an HP 8560 E-series or EC-series spectrum analyzer.

- 337 FN UNLK Fractional N circuitry is unable to lock.

YTO Loop Settling Errors (351 to 354)

These errors are generated when the YTO loop error voltage will not stabilize at an acceptable value during the YTO loop locking routines. These errors only apply to the hardware in an HP 8560 E-series or EC-series

spectrum analyzer.

- 351 SETL FLD YTO error voltage is not settling.
- 352 TWID FLD Unable to bring YTO error voltage DAC's to quiescent point.
- 353 SRCH FLD No acceptable YTO DAC value found.
- 354 LK ITERS Cannot lock. Lock iteration routine terminated.

Sampling Oscillator (355)

This error indicates an unlocked sampling oscillator during the local oscillator (LO) alignment routine. This error only applies to the hardware in an HP 8560 E-series or EC-series spectrum analyzer.

- 355 SMP CAL Sampler unlock condition during calibration routine. This error remains until a successful recalibration is performed.

Span Accuracy Calibration Errors (356 to 361)

These errors are generated when the span accuracy calibration fails. The span accuracy calibration is done during "power up", IF calibration (every 5 minutes), and LO IF realignment routines. Span accuracy calibration sweeps occur during the retrace (dead time) of the main sweep ramp. The firmware then detects any span accuracy calibration errors. These errors only apply to firmware revisions 931216 and later.

- 356 SPAC CAL Sweep data problem finding "bucket 1" of the span accuracy calibration sweep. This error indicates a possible failure of the sweep generator, span attenuator, or main/FM coil sweep switches on the A14 frequency control assembly. Refer to Chapter 10, "Synthesizer Section."
- 357 SPAC CAL Cannot find the "x" intersection for "bucket 1" of the span accuracy calibration sweep. This error indicates a possible failure of the sweep generator, span attenuator, or main/FM coil sweep switches on the A14 frequency control assembly. Refer to Chapter 10, "Synthesizer Section."
- 358 SPAC CAL Sweep data problem finding "bucket 2" of the span accuracy calibration sweep. This error indicates a possible failure of the sweep generator, span attenuator, or main/FM coil sweep switches on the A14 frequency control assembly. Refer to Chapter 10, "Synthesizer Section."

- 359 SPAC CAL Cannot find "x" intersection for "bucket 2" of the span accuracy calibration sweep. This error indicates a possible failure of the sweep generator, span attenuator, or main/FM coil sweep switches on the A14 frequency control assembly. Refer to Chapter 10, "Synthesizer Section."
- 360 SPAC CAL The start bucket correction is out of range. This error indicates a possible failure of the sweep generator on the A14 frequency control assembly. Refer to "Sweep Generator Circuit" in Chapter 10, "Synthesizer Section."
- 361 SPAC CAL The percent of span correction is out of range. This error indicates a possible failure of the sweep generator on the A14 frequency control assembly. Refer to "Sweep Generator Circuit" in Chapter 10, "Synthesizer Section."

Automatic IF Errors (400 to 599)

These error codes are generated when the automatic IF adjustment routine detects a fault. This routine first adjusts amplitude parameters, then resolution bandwidths in this sequence: 300 kHz, 1 MHz, 2 MHz, 100 kHz, 30 kHz, 10 kHz, 3 kHz, 1 kHz, 300 Hz, 100 Hz, 30 Hz, 10 Hz, 3 Hz, and 1 Hz. The routine restarts from the beginning if a fault is detected. Parameters adjusted after the routine begins but before the fault is detected are correct; parameters adjusted later in the sequence are suspect. Refer to "Automatic IF Adjustment" in Chapter 8.

The IF Section relies on the ADC and video circuitry to perform its continuous IF adjustments. IF-related errors occur if the ADC, video circuitry, or A4 assembly linear path is faulty.

- 400 AMPL <300 Unable to adjust amplitude of resolution bandwidths less than 300 Hz.
- 401 AMPL 300 Unable to adjust amplitude of 300 Hz resolution bandwidth.
- 402 AMPL 1K Unable to adjust amplitude of 1 kHz resolution bandwidth.
- 403 AMPL 3K Unable to adjust amplitude of 3 kHz resolution bandwidth.
- 404 AMPL 10K Unable to adjust amplitude of 10 kHz resolution bandwidth.

Errors 405 to 416: When these 10K resolution bandwidth (RBW) error messages appear, use the following steps to check for errors 581 or 582.

1. Press **LINE** to turn the spectrum analyzer off.
2. Press **LINE** to turn the spectrum analyzer on and observe the lower right-hand corner of the display for 10 seconds.
3. If ERR 581 or ERR 582 appears, the fault is most likely caused by the cal oscillator. Refer to errors 581 and 582.
4. If ERR 581 or ERR 582 does not appear, troubleshoot the A5 IF assembly.

Multiple IF Errors During IF adjust: If a FULL IF ADJ sequence (pressing **CAL** and **FULL IF ADJ**) results in IF errors while displaying IF ADJUST STATUS: AMPLITUDE, the cal oscillator on A4 might not be providing the correct output signal. Perform the following steps:

1. Disconnect W30 (white) from A5J4.
2. Connect W30 to the input of a second spectrum analyzer and set its controls as follows:

Center Frequency 10.7 MHz
Reference Level -30 dBm
3. Observe the spectrum analyzer display while pressing **FULL IF ADJ** on the spectrum analyzer. If a -35 dBm signal does not appear, troubleshoot the cal oscillator on A4.
4. If a -35 dBm signal does appear, troubleshoot the A5 IF assembly.

- | | | |
|-----|---------|--|
| 405 | RBW 10K | Unable to adjust 10 kHz resolution bandwidth in first crystal pole. |
| 406 | RBW 10K | Unable to adjust 10 kHz resolution bandwidth in second crystal pole. |
| 407 | RBW 10K | Unable to adjust 10 kHz resolution bandwidth in third crystal pole. |
| 408 | RBW 10K | Unable to adjust 10 kHz resolution bandwidth in fourth crystal pole. |
| 409 | RBW 10K | Unable to adjust 10 kHz resolution bandwidth in first crystal pole. |

- 410 RBW 10K Unable to adjust 10 kHz resolution bandwidth in second crystal pole.
- 411 RBW 10K Unable to adjust 10 kHz resolution bandwidth in third crystal pole.
- 412 RBW 10K Unable to adjust 10 kHz resolution bandwidth in fourth crystal pole.
- 413 RBW 10K Unable to adjust 10 kHz resolution bandwidth in first crystal pole.
- 414 RBW 10K Unable to adjust 10 kHz resolution bandwidth in second crystal pole.
- 415 RBW 10K Unable to adjust 10 kHz resolution bandwidth in third crystal pole.
- 416 RBW 10K Unable to adjust 10 kHz resolution bandwidth in fourth crystal pole.
- 417 RBW 3K Unable to adjust 3 kHz resolution bandwidth in first crystal pole.
- 418 RBW 3K Unable to adjust 3 kHz resolution bandwidth in second crystal pole.
- 419 RBW 3K Unable to adjust 3 kHz resolution bandwidth in third crystal pole.
- 420 RBW 3K Unable to adjust 3 kHz resolution bandwidth in fourth crystal pole.
- 421 RBW 10K Unable to adjust 10 kHz resolution bandwidth in first crystal pole.
- 422 RBW 10K Unable to adjust 10 kHz resolution bandwidth in second crystal pole.
- 423 RBW 10K Unable to adjust 10 kHz resolution bandwidth in third crystal pole.
- 424 RBW 10K Unable to adjust 10 kHz resolution bandwidth in fourth crystal pole.
- 425 RBW 3K Unable to adjust 3 kHz resolution bandwidth in first crystal pole.
- 426 RBW 3K Unable to adjust 3 kHz resolution bandwidth in second crystal pole.
- 427 RBW 3K Unable to adjust 3 kHz resolution bandwidth in third crystal pole.
- 428 RBW 3K Unable to adjust 3 kHz resolution bandwidth in fourth crystal pole.
- 429 RBW 100 Unable to adjust resolution bandwidths less than

300Hz. ADC handshake.

- 430 RBW 300 Unable to adjust 300 Hz resolution bandwidth. ADC handshake.
- 431 RBW 1K Unable to adjust 1 kHz resolution bandwidth. ADC handshake.
- 432 RBW 3K Unable to adjust 3 kHz resolution bandwidth. ADC handshake.
- 433 RBW 10K Unable to adjust 10 kHz resolution bandwidth. ADC handshake.
- 434 RBW 300 300 Hz resolution bandwidth amplitude low in first crystal pole.
- 435 RBW 300 300 Hz resolution bandwidth amplitude low in second crystal pole.
- 436 RBW 300 300 Hz resolution bandwidth amplitude low in third crystal pole.
- 437 RBW 300 300 Hz resolution bandwidth amplitude low in fourth crystal pole.
- 438 RBW 1K 1 kHz resolution bandwidth amplitude low in first crystal pole.
- 439 RBW 1K 1 kHz resolution bandwidth amplitude low in second crystal pole.
- 440 RBW 1K 1 kHz resolution bandwidth amplitude low in third crystal pole.
- 441 RBW 1K 1 kHz resolution bandwidth amplitude low in fourth crystal pole.
- 442 RBW 3K 3 kHz resolution bandwidth amplitude low in first crystal pole.
- 443 RBW 3K 3 kHz resolution bandwidth amplitude low in second crystal pole.
- 444 RBW 3K 3 kHz resolution bandwidth amplitude low in third crystal pole.
- 445 RBW 3K 3 kHz resolution bandwidth amplitude low in fourth crystal pole.
- 446 RBW 10K 10 kHz resolution bandwidth amplitude low in first crystal pole.
- 447 RBW 10K 10 kHz resolution bandwidth amplitude low in second crystal pole.
- 448 RBW 10K 10 kHz resolution bandwidth amplitude low in third crystal pole.

- 449 RBW 10K 10 kHz resolution bandwidth amplitude low in fourth crystal pole.
- 450 IF SYSTM IF hardware failure. Check other error messages.
- 451 IF SYSTM IF hardware failure. Check other error messages.
- 452 IF SYSTM IF hardware failure. Check other error messages.
- 454 AMPL Unable to adjust step gain amplifiers. Check other errors.
- 455 AMPL Unable to adjust fine attenuator of the step gain amplifiers.
- 456 AMPL Unable to adjust fine attenuator of the step gain amplifiers.
- 457 AMPL Unable to adjust fine attenuator of the step gain amplifiers.
- 458 AMPL Unable to adjust first step gain stage.
- 459 AMPL Unable to adjust first step gain stage.
- 460 AMPL Unable to adjust first step gain stage.
- 461 AMPL Unable to adjust second step gain stage.
- 462 AMPL Unable to adjust second step gain stage.
- 463 AMPL Unable to adjust third step gain stage.
- 464 AMPL Unable to adjust third step gain stage.
- 465 AMPL Unable to adjust third step gain stage.
- 466 LIN AMPL Unable to adjust linear amplifier scale.
- 467 AMPL Unable to adjust step gain amplifiers.
- 468 AMPL Unable to adjust third step gain stage.
- 469 AMPL Unable to adjust step gain amplifiers.
- 470 AMPL Unable to adjust third step gain stage.
- 471 RBW 30K Unable to adjust 30 kHz resolution bandwidth in first LC pole.
- 472 RBW 100K Unable to adjust 100 kHz resolution bandwidth in first LC pole.
- 473 RBW 300K Unable to adjust 300 kHz resolution bandwidth in first LC pole.
- 474 RBW 1M Unable to adjust 1 MHz resolution bandwidth in first LC pole.
- 475 RBW 30K Unable to adjust 30 kHz resolution bandwidth in

second LC pole.

- 476 RBW 100K Unable to adjust 100 kHz resolution bandwidth in second LC pole.
- 477 RBW 300K Unable to adjust 300 kHz resolution bandwidth in second LC pole.
- 478 RBW 1M Unable to adjust 1 MHz resolution bandwidth in second LC pole.
- 483 RBW 10K Unable to adjust 10 kHz resolution bandwidth.
- 484 RBW 3K Unable to adjust 3 kHz resolution bandwidth.
- 485 RBW 1K Unable to adjust 1 kHz resolution bandwidth.
- 486 RBW 300 Unable to adjust 300 Hz resolution bandwidth.
- 487 RBW 100 Unable to adjust 100 Hz resolution bandwidth.
- 488 RBW 10 Unable to adjust 100 Hz resolution bandwidth.
- 489 RBW 100 Unable to adjust 100 Hz resolution bandwidth.
- 490 RBW 100 Unable to adjust 100 Hz resolution bandwidth.
- 491 RBW <300 Unable to adjust resolution bandwidths less than 300 Hz. Crystal sweep gain problem.
- 492 RBW 300 Unable to adjust 300 Hz resolution bandwidth. Crystal sweep gain problem.
- 493 RBW 1K Unable to adjust 1 kHz resolution bandwidth. Crystal sweep gain problem.
- 494 RBW 3K Unable to adjust 3 kHz resolution bandwidth. Crystal sweep gain problem.
- 495 RBW 10K Unable to adjust 10 kHz resolution bandwidth. Crystal sweep gain problem.
- 496 RBW 100 Unable to adjust 100 Hz resolution bandwidth. Inadequate Q.
- 497 RBW 100 Unable to adjust 100 Hz resolution bandwidth. Alignment problem.
- 498 RBW 100 Unable to adjust 100 Hz resolution bandwidth. Gain problem.
- 499 CAL UNLK Cal oscillator is unlocked. Verify the unlocked conditions as follows:
 1. Place A4 in its service position and disconnect W51 (gray-yellow) from A4J7.
 2. Connect W51 to the input of another spectrum analyzer. This is the 10 MHz reference for the cal

oscillator.

3. If a 10 MHz signal (approximately 0 dBm) is not present, suspect the A15 RF assembly, the A21 OCXO, or the A15 assembly TCXO (Option 103). If the 10 MHz reference is present, continue with step 4.
4. Reconnect W17 to A4J7 and monitor the tune voltage at A4J9 pin 3 with an oscilloscope.
5. Press **PRESET** on the spectrum analyzer under test.
6. If the voltage is either +15 Vdc or –15 Vdc, the cal oscillator is probably at fault. Normally, the voltage should be near +15 V during a sweep, and between –9 V and +9 V during retrace.

An *intermittent* error 499 indicates the cal oscillator phase-locked-loop probably can lock at 10.7 MHz, but cannot lock at the 9.9 and 11.5 MHz extremes. This may prevent the cal oscillator from adjusting the 1 MHz or 30 kHz through 300 kHz bandwidths. This symptom implies a failure in the oscillator, function block X. (See the A4 log amp/cal oscillator schematic sheet 4 of 4.) The oscillator is unable to tune the required frequency range with the –9 V to +9 V control voltage. Troubleshoot A4CR802 (most probable cause), L801, C808, C809, and U807.

- 500 AMPL 30K Unable to adjust amplitude of 30 kHz resolution bandwidth.
- 501 AMPL .1M Unable to adjust amplitude of 100 kHz resolution bandwidth.
- 502 AMPL .3M Unable to adjust amplitude of 300 kHz resolution bandwidth.
- 503 AMPL 1M Unable to adjust amplitude of 1 MHz resolution bandwidth.
- 504 AMPL 30K Unable to adjust amplitude of 30 kHz resolution bandwidth.
- 505 AMPL .1M Unable to adjust amplitude of 100 kHz resolution bandwidth.
- 506 AMPL .3M Unable to adjust amplitude of 300 kHz resolution bandwidth.
- 507 AMPL 1M Unable to adjust amplitude of 1 MHz resolution bandwidth.
- 508 AMPL 30K Unable to adjust amplitude of 30 kHz resolution

- bandwidth. Insufficient gain during LC bandwidth calibration.
- 509 AMPL .1M Unable to adjust amplitude of 100 kHz resolution bandwidth. Insufficient gain during LC bandwidth calibration.
- 510 AMPL .3M Unable to adjust amplitude of 300 kHz resolution bandwidth. Insufficient gain during LC bandwidth calibration.
- 511 AMPL 1M Unable to adjust amplitude of 1 MHz resolution bandwidth. Insufficient gain during LC bandwidth calibration.
- 512 RBW 100 Unable to adjust 100 Hz resolution bandwidth. Insufficient gain during crystal bandwidth calibration.
- 513 RBW 300 Unable to adjust 300 Hz resolution bandwidth. Insufficient gain during crystal bandwidth calibration.
- 514 RBW 1K Unable to adjust 1 kHz resolution bandwidth. Insufficient gain during crystal bandwidth calibration.
- 515 RBW 3K Unable to adjust 3 kHz resolution bandwidth. Insufficient gain during crystal bandwidth calibration.
- 516 RBW 10K Unable to adjust 10 kHz resolution bandwidth. Insufficient gain during crystal bandwidth calibration.
- 517 RBW 100 Unable to adjust 100 Hz resolution bandwidth. Crystal sweep problem.
- 518 RBW 300 Unable to adjust 300 Hz resolution bandwidth. Crystal sweep problem.
- 519 RBW 1K Unable to adjust 1 kHz resolution bandwidth. Crystal sweep problem.
- 520 RBW 3K Unable to adjust 3 kHz resolution bandwidth. Crystal sweep problem.
- 521 RBW 10K Unable to adjust 10 kHz resolution bandwidth. Crystal sweep problem.
- 522 RBW 10K Unable to adjust symmetry of 10 kHz resolution bandwidth in first crystal pole.
- 523 RBW 10K Unable to adjust symmetry of 10 kHz resolution bandwidth in second crystal pole.
- 524 RBW 10K Unable to adjust symmetry of 10 kHz resolution bandwidth in third crystal pole.
- 525 RBW 10K Unable to adjust symmetry of 10 kHz resolution bandwidth in fourth crystal pole.

- 526 RBW <300 ADC timeout during IF ADJUST of <300 Hz resolution bandwidth.
- 527 RBW <300 Step gain correction failed for <300 Hz resolution bandwidth. Check narrow BW SGO attenuator.
- 528 RBW <300 Calibration of dc level at ADC failed for <300 Hz resolution bandwidth.
- 529 RBW <300 Invalid demodulated data for <300 Hz resolution bandwidth flatness and IF down-converter. Demod data for calibration may be bad.
- 530 RBW <300 Adjustment of VCXO down-converter failed. Narrow bandwidth VCXO calibration failed.
- 531 RBW <300 Flatness correction data for resolution bandwidths <300 Hz not acceptable.
- 532 RBW <300 Absolute gain data for resolution bandwidths <300 Hz not acceptable.
- 533 RBW <300 ADC timeout adjusting resolution bandwidths less than 300 Hz. Timeout during data sampling narrow bandwidth chunk.
- 534 RBW <300 Unable to do frequency count of CAL OSC using IF down-converter when adjusting resolution bandwidths less than 300 Hz.
- 535 RBW <300 Unable to obtain adequate FM demod range to measure 500 Hz IF filter with resolution bandwidths less than 300 Hz.
- 536 RBW <300 Unable to auto-range chirp signal while setting VCXO or doing flatness calibration with resolution bandwidths less than 300 Hz.
- 537 RBW <300 Unable to auto-range CW CAL OSC signal to count VCXO signal with resolution bandwidths less than 300 Hz.
- 538 RBW <300 Shape of 500 Hz IF filter appears too noisy to adjust VCXO down-converter for resolution bandwidths less than 300 Hz.
- 539 RBW <300 Unable to auto-range the CW CAL OSC signal to pretune the VCXO for resolution bandwidths less than 300 Hz.
- 540 RBW <300 Unable to find CW CAL OSC signal during VCXO pretune at power-up with resolution bandwidths less than 300 Hz.
- 550 IDCALOSC CAL Oscillator ID. Indicates incompatible hardware. Cal oscillator on A16 Cal Osc not expected.

- 551 LOG AMPL LOG Board ID. Indicates incompatible hardware. Cal oscillator on A4 assembly not expected.
- 552 LOG AMPL Unable to adjust amplitude of log scale.
- 553 LOG AMPL Unable to adjust amplitude of log scale.
- 554 LOG AMPL Unable to adjust amplitude of log scale.
- 555 LOG AMPL Unable to adjust amplitude of log scale.
- 556 LOG AMPL Unable to adjust amplitude of log scale.
- 557 LOG AMPL Unable to adjust amplitude of log scale.
- 558 LOG AMPL Unable to adjust amplitude of log scale.
- 559 LOG AMPL Unable to adjust amplitude of log scale.
- 560 LOG AMPL Unable to adjust amplitude of log scale.
- 561 LOG AMPL Unable to adjust amplitude of log scale. Possible problem in second step gain.
- 562 LOG AMPL Unable to adjust amplitude of log scale. Possible problem in second step gain.
- 563 LOG AMPL Unable to adjust amplitude of log scale. Possible problem in third step gain range.
- 564 LOG AMPL Unable to adjust amplitude of log scale.
- 565 LOG AMPL Unable to adjust amplitude of log scale.
- 566 LOG AMPL Unable to adjust amplitude of log scale.
- 567 LOG AMPL Unable to adjust amplitude of log scale. Possible problem in Log offset/Log Expand stage.
- 568 LOG AMPL Unable to adjust amplitude of log scale. Possible problem in Log offset/Log Expand stage.
- 569 LOG AMPL Unable to adjust amplitude of log scale. Possible problem in Log offset/Log Expand stage.
- 570 LOG AMPL Unable to adjust amplitude of log scale. Possible problem in Log offset/Log Expand stage.
- 571 AMPL Unable to adjust step gain amplifiers.
- 572 AMPL 1M Unable to adjust amplitude of 1 MHz resolution bandwidth.
- 573 LOG AMPL Unable to adjust amplitude of log scale. Check video offset circuitry.
- 574 LOG AMPL Unable to adjust amplitude of log scale. Check video offset circuitry.
- 575 LOG AMPL Unable to adjust amplitude of log scale. Check video

offset circuitry.

- 576 LOG AMPL Unable to adjust amplitude of log scale. Check video offset circuitry.
- 577 LOG AMPL Unable to adjust amplitude of log scale. Check video offset circuitry.
- 578 LOG AMPL Limiter calibration error from DC logger calibration.
- 579 LOG AMPL Attenuator CAL level error from DC logger calibration.
- 580 LOG AMPL calibration level error from DC logger calibration.
- 581 AMPL Unable to adjust 100 kHz resolution bandwidth and resolution bandwidths less than or equal to 10 kHz. ADC/CALOSC handshake calibration problem in crystal sweep. Refer to Error 582.
- 582 AMPL Unable to adjust 100 kHz resolution bandwidth and resolution bandwidths less than or equal to 10 kHz. Bad CALOSC calibration in sweep rate. Test the 100 kHz resolution bandwidth filter 3 dB bandwidth as follows:
1. Connect the CAL OUTPUT signal (A4J8) to the INPUT 50 Ω
 2. Press **PRESET** and set the controls as follows:
CENTER FREQ 300 MHz
SPAN500 kHz
Resolution Bandwidth100 kHz
LOG dB/DIV 1 dB
REF LEVEL.....adjust to place signal peak at top of the screen
 3. Press **PEAK SEARCH** and **MARKER DELTA** and turn the knob clockwise to position the marker until the delta MKR reads $-3 \text{ dB} \pm 0.1 \text{ dB}$.
 4. Press **MARKER DELTA** and move the marker to the other side of the peak until the delta MKR reads $0 \text{ dB} \pm 0.1 \text{ dB}$.
 5. If the delta MKR frequency is between 90 kHz and 110 kHz, the 100 kHz resolution bandwidth is working properly. If the frequency is outside these limits, read the following information on the A4 cal oscillator sweep generator.

If the 100 kHz resolution bandwidth works properly, the cal oscillator sweep generator is failing to sweep its oscillator frequency at the correct rate. The error is detected in sweeping on the skirts of the 100 kHz

resolution bandwidth.

A properly operating sweep generator generates a series of negative-going parabolas. These parabolas generate the sweeps used to adjust resolution bandwidths of 10 kHz and less. Check the sweep generator with the following steps. Refer also to "300 Hz to 3 kHz resolution bandwidth out of specification" in the A4 cal oscillator troubleshooting text in Chapter 8.

1. Remove the shields.
2. Connect an oscilloscope probe to A4U804C pin 8.
3. On the spectrum analyzer, press **CAL** and **FULL IF ADJ**.
4. Approximately 8 seconds after starting the **FULL IF ADJ**, check for negative-going parabolas (similar to half-sine waves) 5 ms wide and approximately -4 V at their peak. Refer to Chapter 8, "IF Section," for more information on the A4 log amp/cal oscillator assembly.

583 RBW 30K Unable to adjust 30 kHz resolution bandwidth.

584 RBW 100K Unable to adjust 100 kHz resolution bandwidth.

585 RBW 300K Unable to adjust 300 kHz resolution bandwidth.

586 RBW 1M Unable to adjust 1 MHz resolution bandwidth.

587 RBW 30K Unable to adjust 30 kHz resolution bandwidth.

588 RBW 100K Unable to adjust 100 kHz resolution bandwidth.

589 RBW 300K Unable to adjust 300 kHz resolution bandwidth.

590 RBW 1M Unable to adjust 1 MHz resolution bandwidth.

591 LOG AMPL Unable to adjust amplitude of log scale.

592 LOG AMPL Unable to adjust amplitude of log scale.

593 LOG TUNE Limiter calibration tune error from DC logger calibration.

594 LOG OFST Attenuator calibration offset error from DC logger calibration.

595 LOG ATTN Attenuator calibration absolute error from DC logger calibration.

596 LOG FID Fidelity error from DC logger calibration.

597 LOG OFST Fidelity offset error from DC logger calibration.

598 LOG OFST Fidelity offset unstable from DC logger calibration.

599 LOG GAIN Fidelity gain error from DC logger calibration.

System Errors (600 to 651)

ADC timeout errors occur if the A2 controller assembly frequency counter is faulty. Refer to Chapter 7, "ADC/Interface Section."

600 SYSTEM Hardware/firmware interaction; check other errors.

601 SYSTEM Hardware/firmware interaction; check other errors.

650 OUTOF RG ADC input is outside of the ADC range.

651 NO IRQ Microprocessor is not receiving interrupt from ADC.

Digital and Checksum Errors (700 to 799)

EEROM Checksum Errors (700 to 704)

Faults on the A2 controller assembly can cause these errors. Refer to Chapter 9, "Controller Section." Although some of these errors might result in a blanked display, it is possible to read these errors over HP-IB. Refer to "Troubleshooting to a Functional Section" in this chapter.

The EEROM on A2 is used to store data for frequency response correction, elapsed time, focus, and intensity levels. Error codes from 700 to 703 indicate that some part of the data in EEROM is invalid. An EEROM error could result from either a defective EEROM or an improper sequence of storing data in EEROM. Check the EEROM with the following steps:

1. Place the WR PROT/WR ENA jumper on the A2 controller assembly in the WR ENA position.
2. On the spectrum analyzer, press **CAL**, **MORE 1 OF 2**, **SERVICE CAL DATA**, **FLATNESS**, and **FLATNESS DATA**. Enter a value of 130. Press **PREV MENU**, **STORE DATA**, **YES**, and **DISPLAY**.
3. Press **INTEN**, enter an intensity value of 90, and press **STORE INTEN**.
4. Press **MORE 1 OF 2**, **FOCUS**, enter a focus value of 128, and press **STORE FOCUS**. Press **LINE** to turn the spectrum analyzer off, then on, cycling the power.
5. If errors are still present, the EEROM A2U501 is defective. Refer to the EEROM replacement procedure in Chapter 3.

- 700 EEROM Checksum error of EEROM A2U501.
- 701 AMPL CAL Checksum error of frequency response correction data.
- 702 ELAP TIM Checksum error of elapsed time data.
- 703 AMPL CAL Checksum error of frequency response correction data.
 Default values being used.
- 704 PRESELECT Checksum error of customer preselector peak data.
 External preselector data recalled in internal mode, or
 internal preselector data recalled in external mode. To
 clear the error, press **RECALL**, **MORE 1 OF 2**, **FACTORY**
 PRSELPK, **SAVE**, and **SAVE PRSEL PK**.

Program ROM Checksum Errors (705 to 710)

The instrument power-on diagnostics perform a checksum on each programmed ROM (A2 controller assembly). If an invalid checksum is found for a particular ROM, an error code is generated. If a defective programmed ROM is found, replace it with another ROM with the same HP part number. Refer to Chapter 4, "Replaceable Parts."

Although some of these errors might result in a blanked display, it is possible to read these errors over HP-IB. Refer to "Troubleshooting to a Functional Section" in this chapter.

- 705 ROM U306 Checksum error of program ROM A2U306.
- 706 ROM U307 Checksum error of program ROM A2U307.
- 707 ROM U308 Checksum error of program ROM A2U308.
- 708 ROM U309 Checksum error of program ROM A2U309.
- 709 ROM U310 Checksum error of program ROM A2U310.
- 710 ROM U311 Checksum error of program ROM A2U311.

RAM Check Errors (711 to 716)

The instrument power-on diagnostics check the program RAM. This includes the two RAMs used for STATE storage. If any STATE information is found to be invalid, all data in that RAM is destroyed. A separate error code is generated for each defective program RAM. All RAM is backed-up by battery. See "State- and Trace- Storage Problems" in Chapter 9.

- 711 RAM U303 Checksum error of system RAM A2U303.
- 712 RAM U302 Checksum error of system RAM A2U302.

713 RAM U301 Checksum error of system RAM A2U301.

714 RAM U300 Checksum error of system RAM A2U300.

715 RAM U305 Checksum error of system RAM A2U305.

716 RAM U304 Checksum error of system RAM A2U304.

Microprocessor Error (717)

717 BAD uP Microprocessor not fully operational. Refer to Chapter 9, "Controller Section."

Battery Problem (718)

If STATE or TRACE data is found to be corrupt, the processor tests the display RAMs and the program RAMs containing the STATE information. If the RAMs are working properly, this error message is generated. To check the BT1 battery and the battery backup circuitry, refer to "STATE and TRACE Storage Problems" in Chapter 9.

718 BATTERY? Nonvolatile RAM not working; check battery BT1. This error can also be generated if the battery has been disconnected then reconnected. If this is the cause, cycling power clears the error.

Model Number Error (719)

If this error occurs, return the instrument to a service center for repair.

719 MODEL #? Could not read ID string from EEROM A2U501.

System Errors (750 to 759)

These errors often require troubleshooting the A2 controller and A3 interface assemblies.

750 SYSTEM Hardware/firmware interaction, zero divide. Check for other errors.

751 SYSTEM Hardware/firmware interaction, floating point overflow. Check for other errors.

752 SYSTEM Hardware/firmware interaction, floating point underflow. Check for other errors.

753 SYSTEM Hardware/firmware interaction, log error. Check for other errors.

754 SYSTEM Hardware/firmware interaction, integer overflow. Check for other errors.

- 755 SYSTEM Hardware/firmware interaction, square root error. Check for other errors.
- 756 SYSTEM Hardware/firmware interaction, triple overflow. Check for other errors.
- 757 SYSTEM Hardware/firmware interaction, BCD overflow. Check for other errors.
- 758 SYSTEM Unknown system error.
- 759 SYSTEM Hardware/firmware interaction. Code invoked for wrong instrument.

Fast ADC Error (760)

This error applies only to EC-series instruments and to E-series instruments with fast ADC (Option 007).

- 760 NO FADC The FADC board did not respond properly to initialization commands.

Option Module Errors (800 to 899)

These error codes are reserved for option modules, such as the HP 85629 test and adjustment module and the HP 85620A mass memory module. Refer to the option module manual for a listing of error messages.

User-Generated Errors (900 to 999)

These error codes indicate user-generated errors.

- 900 TG UNLVL Tracking generator output is unleveled.
- 901 TGFrqLmt Tracking generator output unleveled because START FREQ is set below tracking generator frequency limit (300 kHz).
- 902 BAD NORM The state of the stored trace does not match the current state of the spectrum analyzer.
- 903 A > DLMT Unnormalized trace A is off-screen with trace math or normalization on.
- 904 B > DLMT Calibration trace (trace B) is off-screen with trace math or normalization on.
- 905 EXT REF Unable to lock cal oscillator when set to external frequency reference. Check that the external 10 MHz reference is within tolerance.
- 906 OVENCOLD The oven-controlled crystal oscillator (OCXO) oven is cold.

- 907 DO IF CAL Unit is still performing IF calibrations, or is in need of IF calibrations which were not yet done due to an OVENCOLD condition, since an OVENCOLD error is indicative of a bandwidth ≤ 1 kHz not getting calibrated.
- 908 BW>>SPCG Channel bandwidth is too wide, compared to the channel spacing, for a meaningful adjacent channel power computation.
- 909 SPANACP The frequency span is too small to obtain a valid adjacent channel power (ACP) measurement.
- 910 SPAN>ACP The frequency span is too wide, compared to the channel bandwidth, to obtain a valid adjacent channel power (ACP) measurement.

Block Diagram Description

The spectrum analyzer is comprised of the six main sections listed below. See [Figure 6-6 on page 330](#). The following descriptions apply to the Simplified Block Diagram and Overall Block Diagram located at the end of this chapter. Assembly level block diagrams are located in Chapters 7 through 12.

Figure 6-6 Functional Sections

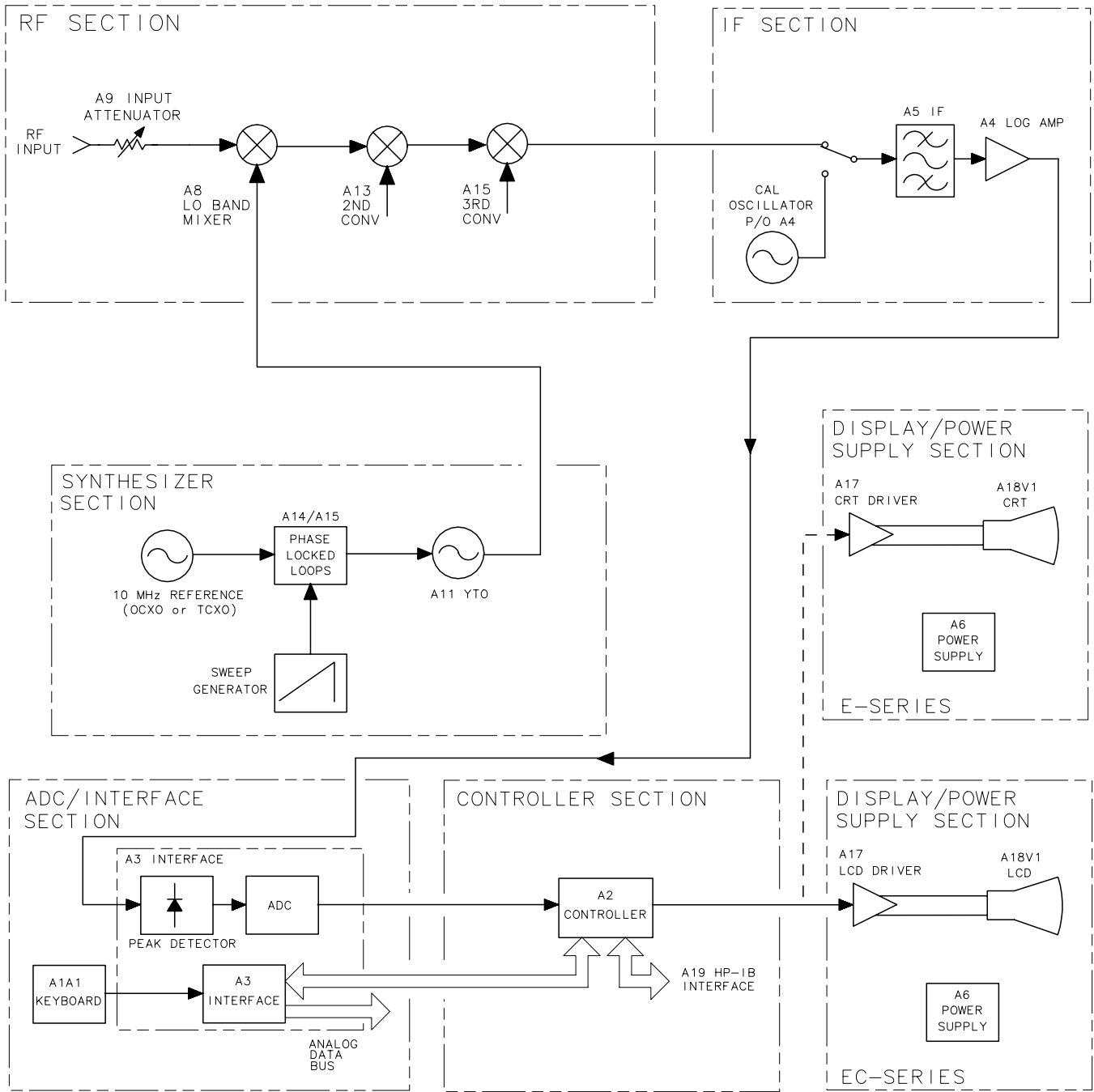

sj117

RF Section

The RF Section includes the following assemblies:

- A7 LODA (LO distribution amplifier)
- A8 low band mixer
- A9 input attenuator
- A10 tracking generator (Option 002)
- A11 YTO (YIG-tuned oscillator)
- A13 second converter
- A14 frequency control assembly (also in synthesizer section)
- A15 RF assembly (also in synthesizer section)
- FL1, FL2 low-pass filters

The RF section converts all input signals to a fixed IF of 10.7 MHz. The RF section microcircuits are controlled by signals from the A14 frequency control and A15 RF assemblies.

The HP 8560E/EC spectrum analyzer uses triple conversion to produce the 10.7 MHz IF and a fourth conversion used only in resolution bandwidths ≤ 100 Hz. A8 low band mixer up-converts the RF input to a first IF of 3.9107 GHz. A13 second converter down-converts the 3.9107 GHz IF to an IF of 310.7 MHz. A third conversion on the A15 RF assembly down-converts the second IF to the 10.7 MHz third IF. A fourth conversion on the A4 log amplifier assembly down-converts the third IF to the 4.8 kHz fourth IF used only in resolution bandwidths ≤ 100 Hz.

A7 LODA

The A7 LODA (LO distribution amplifier) levels the output of the A11 YTO and distributes the power to the front-panel 1ST LO OUTPUT, A8 Low Band Mixer, Option 002 Tracking Generator, and A15U100 Sampler. The leveling circuitry is on the A14 Frequency Control Assembly.

A8 Low Band Mixer

A8 low band mixer is dc-coupled and contains a limiter. In spectrum analyzers with serial number prefix 3632A and greater, the A8 low band mixer also contains an LO buffer amplifier and an IF preamplifier. A14 frequency control board assembly provides power for these amplifiers via cable harness W12.

A9 Input Attenuator

The attenuator is a 50 Ω precision, coaxial step attenuator. Attenuation in 10 dB steps from 0 dB to 70 dB is accomplished by switching the signal path through one or more of the three resistive pads. The attenuator automatically sets to 70 dB and DC block when the spectrum analyzer turns off, providing ESD protection. (Note that the input attenuator is not field-repairable.)

A11 YTO

A11 is a YTO (YIG-tuned oscillator). YIG (yttrium-iron-garnet) is a ferro-magnetic material which is polished into a small sphere and precisely oriented in a magnetic field. Changes in this magnetic field alter the frequency generated by the YTO. Current control of the magnetic field surrounding the YIG sphere tunes the oscillator to the desired frequency.

A13 Second Converter

The A13 second converter down-converts the 3.9107 GHz 1st IF to a 310.7 MHz 2nd IF. The converter generates a 3.6 GHz second LO by multiplying a 600 MHz reference. Bandpass filters remove unwanted harmonics of the 600 MHz driving signal. First IF and 2nd LO signals are filtered by cavity filters.

Second IF Distribution Amplifier (part of A15)

The second IF distribution amplifier (SIFA) amplifies and filters the second IF. (Option 001 instruments provide the pre-filtered signal at the rear panel 2ND IF OUTPUT.)

The external mixing input from the front-panel IF INPUT connector is also directed through the SIFA. A dc bias is placed onto the IF INPUT line for biasing external mixers.

Third Converter (part of A15)

The third converter down-converts the 310.7 MHz IF to 10.7 MHz. A PIN-diode switch selects the LO signal used. For normal operation, a 300 MHz LO signal is used. The signal is derived from the 600 MHz reference PLL. During signal identification (SIG ID ON) for Option 008, the 298 MHz SIG ID oscillator is fed to the double balanced mixer on alternate sweeps.

Flatness Compensation Amplifiers (part of A15)

The flatness compensation amplifiers amplify the output of the double-balanced mixer. The variable gain of the amplifier (8 to 32 dB) compensates for flatness variations within a band. Band conversion loss is compensated by step gain amplifiers in the IF section.

Control for the amplifiers originates from two DACs on the A3 interface assembly. (DAC values are interpolated approximately every 17 MHz based on data obtained during the frequency response adjustment.) A15 flatness-compensation control circuitry converts the RF GAIN voltage, from A3, into two currents: RF GAIN1 and RF GAIN2. These currents drive PIN diodes in the flatness compensation amplifiers.

Synthesizer Section

The first LO is phase-locked to the internal 10 MHz standard of the instrument by four PLLs. See [Figure 6-7 on page 335](#).

The Reference PLL supplies reference frequencies for the instrument. The three remaining PLLs tune and phase-lock the LO through its frequency range. To tune the LO to a particular frequency, the instrument microprocessor must set the programmable feedback dividers (N) and reference dividers (R) contained in each PLL.

Sweeping the First LO

The spectrum analyzer uses a method called lock and roll to sweep the first LO (A11 YTO) for LO spans >2 MHz. This involves phase-locking the spectrum analyzer at the start frequency during the retrace of the sweep, then sweeping through the desired frequency range in an unlocked condition. The sweep ramp, which sweeps the LO during the roll part of the lock and roll process, is generated on the A14 frequency control assembly. It is applied to either A11 YTO main coil or the A11 YTO FM coil. For LO spans ≤2.0 MHz, the YTO PLL remains locked and the fractional N PLL sweeps while remaining phase locked. The frequency/span relationships are as follows:

Table 6-2

Location of Assembly Troubleshooting Text

| A11 YTO Spanwidth | Sweep Applied To |
|------------------------|--------------------------------|
| 20.1 MHz to 3.8107 GHz | A11 YTO main coil |
| 2.01 MHz to 20.0 MHz | A11 YTO FM coil |
| 100 Hz to 2 MHz | Fractional N phase locked loop |

When the sweep ramp is applied to the YTO, the spectrum analyzer must prevent this loop from trying to compensate for changes in the output frequency. To accomplish this, the spectrum analyzer breaks the PLL by disconnecting the YTO PLL phase detector output.

Reference PLL (part of A15)

The 600 MHz reference PLL provides 600 MHz for the second LO and the A10 tracking generator (Option 002), 300 MHz for the third LO, and the sampling oscillator reference and 10 MHz to the fractional N PLL. The reference PLL is locked to a 10 MHz OCXO (oven-compensated

crystal oscillator) or an Option 103 TCXO (temperature-compensated crystal oscillator). The PLL can also be locked to an external frequency reference.

The 10 MHz reference also supplies the reference for the frequency counter on the A2 controller assembly, and the cal oscillator on the A4 log amplifier assembly.

YTO PLL (A7, A11, part of A14, part of A15)

The YTO PLL produces the first LO of the instrument (3.0 to 6.81 GHz). The YTO output is mixed with a harmonic of the sampling oscillator in the sampler (A15U100), and the resulting frequency is phase-locked to the output of the fractional N PLL.

The A15U100 sampler mixes the LO signal from the A7 LODA with a harmonic of the sampling oscillator. The mixing product, the sampler IF, is between 60 and 96 MHz (same frequency range as the fractional N PLL).

Offset Lock Loop (part of A15)

The 285 MHz to 297.2 MHz sampling oscillator is used to sample the YTO. By changing the offset lock loop programmable dividers, the YTO frequency can be changed.

Figure 6-7 Phase Lock Loops

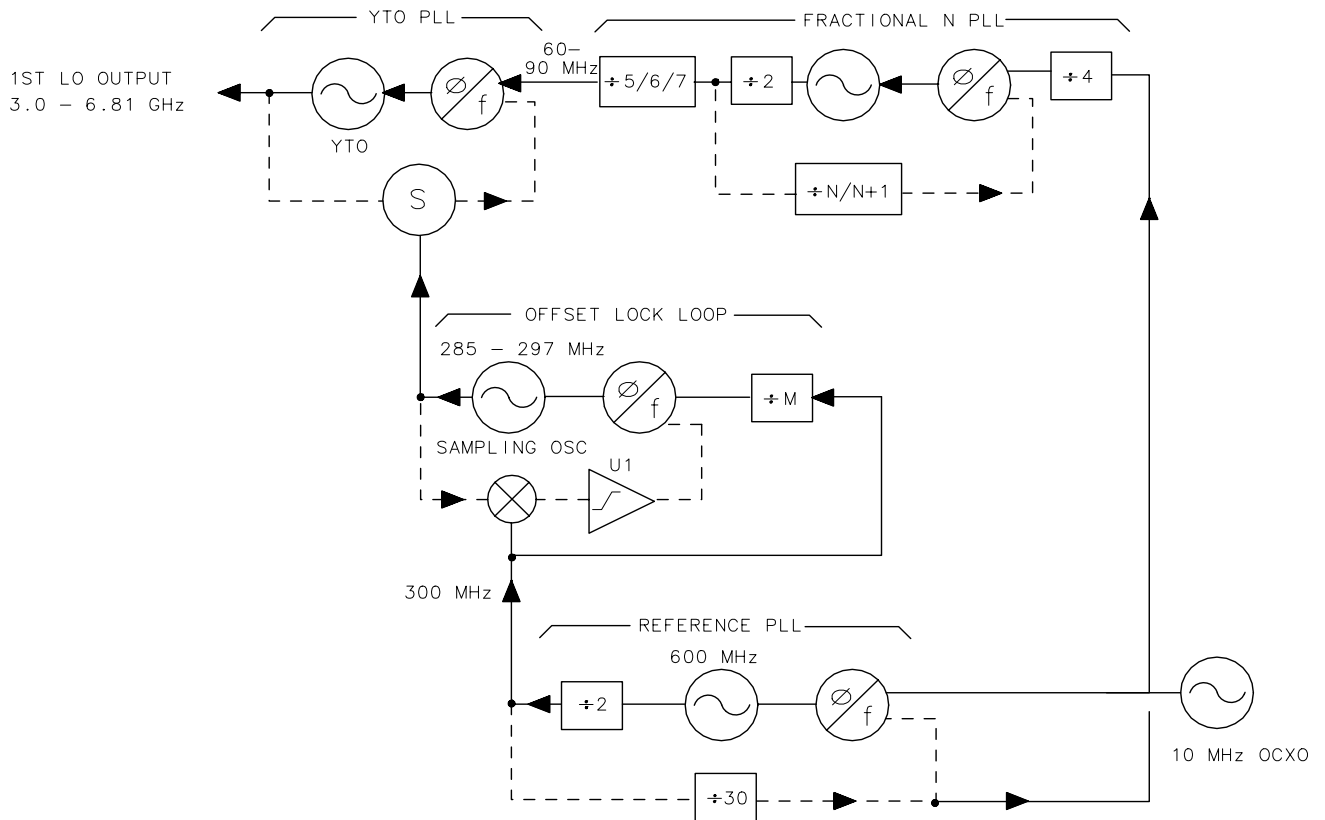

sj116e

Fractional N PLL (part of A14)

The fractional N PLL produces an output of 60 MHz to 96 MHz. This PLL output serves as the reference frequency for the YTO PLL. A one-to-one relationship in frequency tracking exists between the fractional N PLL and the YTO. A change of 1 MHz in the fractional N PLL will produce a 1 MHz change in the YTO frequency.

IF Section

The IF section processes the 10.7 MHz output of the RF section and sends the detected video to the ADC/interface section. The following major assemblies are included in this section:

- A3 interface assembly
- A4 log amplifier/cal oscillator assembly
- A5 IF assembly

The HP 8560E/EC uses trace-data manipulation to generate the 5 dB/DIV scale from the 10 dB/DIV scale. The A3 interface assembly amplifies and offsets the 10 dB/DIV video to generate the 2 dB/DIV scale. The 1 dB/DIV scale is generated from the 2 dB/DIV scale through trace data manipulation.

The first 50 dB of IF gain (log and linear mode) is achieved using the linear step-gain amplifiers of the A5 assembly. The A4 assembly video-offset circuit provides the remaining 60 dB of log mode IF gain. The A4 assembly linear amplifiers provide 40 dB of linear mode gain. IF gain steps of less than 10 dB (regardless of the reference level) are accomplished on the A5 assembly.

A4 Log Amplifier/Cal Oscillator Assembly

The A4 log amplifier has separate log and linear amplifier paths. After amplification, the signal path consists of a linear detector, video log amp, buffer amplifier, video offset, and video buffer amplifier. Other auxiliary functions include the frequency counter prescaler/conditioner, the AM/FM demodulator, and down-conversion to 4.8 kHz for digital resolution bandwidths of 1 Hz through 100 Hz.

The cal oscillator, which is part of A4, supplies the stimulus signal for automatic IF adjustments. Normally, the oscillator operates only during retrace (for a few milliseconds) to adjust part of the IF. (All IF parameters will be re-adjusted approximately every five minutes.) With continuous IF adjust on, a group of IF parameters are adjusted during each retrace period (non-disruptive). If continuous IF adjust is off, the most recent IF calibration data will be used.

The IF parameters adjusted include step gains, log amplifier gain and offset, bandwidth centering, 3 dB bandwidth, bandwidth amplitude, crystal-filter symmetry, and oscillator frequency used in 1 Hz through 100 Hz resolution bandwidths.

The cal oscillator output has three forms (all -35 dBm):

- 10.7 MHz
- 9.9 to 11.5 MHz in 100 kHz steps
- Frequency sweeps from 20 kHz to 2 kHz centered at 10.7 MHz (lasting 5 to 60 ms respectively)

The purpose of these signals is to:

- adjust gains, log amps, and video slopes and offsets
- adjust 3 dB bandwidth and center frequencies of LC resolution BW filters (30 kHz through 1 MHz)
- adjust 3 dB bandwidth, symmetry, and gain of the crystal resolution BW filters (300 Hz through 10 kHz)

- adjust gain and gain-vs-frequency for digital resolution bandwidths (1 Hz through 100 Hz)

A5 IF Assembly

The A5 IF assembly has four crystal filter poles, four LC filter poles, and step gain amplifiers. The crystal filters provide resolution bandwidths of 300 Hz to 10 kHz. The LC filters provide resolution bandwidths of 30 kHz to 2 MHz. All filter stages are in series. PIN diode switches bypass unwanted stages.

An automatic IF adjustment, in spectrum analyzer firmware, sets center frequency and 3 dB bandwidth of all filter poles through varactor and PIN diodes. The firmware also controls crystal-pole symmetry and the step gain amplification.

ADC/Interface Section

The ADC/interface section is the link between the controller section and the rest of the spectrum analyzer. It controls the RF, synthesizer, and IF sections through address and data lines on the W2 control cable (analog bus). Analog signals from these sections are monitored by the ADC (analog to digital converter) circuit on the ADC/interface section.

The ADC/interface section includes the A3 interface assembly, A1A1 keyboard, and A1A2 RPG (front-panel knob). The A3 assembly includes log expand, video filter, peak detector, track-and-hold, real-time DACs, RF gain DACs, +10 V reference, and ADC circuitry. The digital section includes ADC ASM, sweep trigger, keyboard interface, RPG interface, and analog bus interface circuitry.

ADC

The HP 8560E/EC spectrum analyzer can digitize signals with either the main ADC on the A3 interface assembly or with fast ADC circuitry, which is available as a standard feature, located on the A2 controller board, on 8560EC instruments, and is available as an option, located on the A16 board (Option 007) on 8560E instruments. The main ADC is used for digitizing video signals when the sweep time is ≥ 30 ms and various other signals, such as PLL error voltages. The fast ADC is used only to digitize video signals for sweep times < 30 ms.

Main ADC (part of A3)

For sweep times ≥ 30 ms, the spectrum analyzer uses a successive approximation type of ADC. The main ADC has 10-bit resolution but it is realized with 12-bit hardware. The ADC algorithmic state machine (ADC ASM) controls the interface between the start/stop control and the ADC, switching between positive and negative peak detectors when the NORMAL detector mode is selected, and switching the ramp counter into the ADC for comparison to the analog sweep ramp.

Fast ADC in 8560 EC-series instruments

Fast ADC is a standard feature in all 8560EC instruments. When sweep times <30 ms are selected, the spectrum analyzer digitizes video signals with the fast ADC circuitry on the A2 controller board. The fast ADC uses an 8-bit flash ADC that is sampled at a 12 MHz rate. Only POS PEAK, NEG PEAK, and SAMPLE detector modes are available with the fast ADC; NORMAL detector mode is not available. Pre-triggering is possible with the fast ADC.

A16 Fast ADC (8560 E-series only)

When option 007 is installed, and sweep times <30 ms are selected, the spectrum analyzer digitizes video signals with the A16 fast ADC. The fast ADC uses an 8-bit flash ADC that is sampled at a 12 MHz rate. Only POS PEAK, NEG PEAK, and SAMPLE detector modes are available with the fast ADC; NORMAL detector mode is not available. Pre-triggering is possible with the fast ADC.

Log Expand/Video Functions

The A3 interface assembly performs log expand and offset functions. The log expand/log offset amplifier provides a 2 dB/div log scale. When the main ADC is used, the 5 dB/div scale is derived by multiplying the digitized 10 dB/div trace data by two in the CPU. When the fast ADC is used, the 5 dB/div scale is derived by amplifying the video signal by two. The 1 dB/div scale is derived by either multiplying the 2 dB/div trace data by two (main ADC) or amplifying the video signal by two (fast ADC).

The spectrum analyzer uses two types of video filters. An RC low-pass circuit provides 300 Hz to 3 MHz video bandwidths. Video bandwidths of 1 Hz to 100 Hz are generated using digital filtering. When a digital filter is selected, a \mathcal{D} appears along the left edge of the CRT, indicating that something other than the normal detector mode is being used. Digitally filtered bandwidths use a sample detector.

After filtering, the video is sent to the positive and negative peak detectors. These detectors are designed for optimum pulse response. The positive peak detector resets at the end of each horizontal "bucket" (there are 601 such buckets across the screen). The negative peak detector resets at the end of every other bucket. When reset, the output of the peak detector equals its input.

Triggering

The HP 8560E/EC has five trigger modes: free run, single, external, video, and line. The free run and single trigger signal comes from the 1 MHz ADC clock. The line trigger signal comes from the A6 power supply. Video triggering originates from the video filter buffer circuit on A3. External triggering requires either a high or low TTL logic level as determined by the setting of the trigger polarity function. The external

trigger signal is received from a rear panel BNC connector. A DAC in the trigger circuit sets the video trigger level. The trigger circuit is responsible for setting HSCAN high.

Controller Section

The controller section includes the A2 controller assembly and A19 HP-IB assembly. The battery on the rear panel provides battery backup for state and trace storage.

In 8560EC instruments the A2 contains the CPU, RAM, ROM, the display ASM, Fast ADC circuitry, HP-IB interface, control, frequency counter, display RAM, option module interface, and EEROM.

In 8560E instruments the A2 contains the CPU, RAM, ROM, the display ASM and line generators, CRT blanking, focus, intensity, HP-IB interface, control, frequency counter, display RAM, option module interface, and EEROM. In 8560E instruments the A2 assembly controls the A17 CRT driver through W7.

The A19 HP-IB is a mechanical interface between the standard HP-IB connector and the ribbon cable connector on the A2 controller assembly.

All six RAM ICs (there are only four RAM ICs on newer A2 controller assemblies) are battery-backed. The battery-backed RAM stores trace information (two display memory RAMs) and spectrum analyzer state information (two program RAMs). A total of eight traces and ten states may be stored. Typical battery life is five years with the lithium battery. Trace and state information may be retained for up to 30 minutes with a dead battery and power turned off. This is due to the very low data retention current of the RAMs.

EEROM

The EEROM stores important amplitude-related correction data. This includes data for LODA DACs and RF Gain DACs (flatness correction). The spectrum analyzer serial number, model number, and installed options are also stored in EEROM.

Firmware

The spectrum analyzer firmware reads the model number and installed options from the EEROM to determine how to respond to certain keystrokes.

Display ASM

Much of the miscellaneous digital control is performed by A2U100. U100 functions as the display ASM (algorithmic state machine) and character ROM. It also converts the 16-bit CPU data bus to an 8-bit data bus for the rest of the spectrum analyzer.

Display/Power Supply Section

A6 Power Supply

The A6 power supply is a switching supply operating at 40 kHz for low voltages in both EC-series and E-series instruments.

In E-series instruments, the power supply also provides the 30 kHz signal for the CRT supplies (cathode, filament, +110 Vdc, and post accelerator). The A6A1 high voltage module contains the high-voltage transformer and post-accelerator multiplier. Power is distributed through W8 to A17 and through W1 to the rest of the assemblies. A6A1W2 supplies CRT cathode and filament voltages to the A17 assembly.

The speed of the spectrum analyzer fan is variable. A thermistor on A6 senses the temperature and adjusts the fan speed accordingly. This allows the spectrum analyzer to run quietly in most room-temperature environments and faster (louder) only when necessary.

A17 LCD Display Driver (EC-series)

The display is an LCD color flat panel screen with 640 X 480 VGA resolution. A connector for an external VGA is available at the rear panel. The A17A1 backlight supply provides the high voltage to supply the two backlights in the LCD display. The LCD display is not adjustable.

The display driver board consists of the Hitachi 7707 processor, an Actel FPGA, DRAM, SRAM, a filter circuit, and a video DAC. This board monitors the 8560 EC-series controller board, copies display instructions to local memory, creates a bitmap from the data, and generates the signals needed to drive the LCD and a VGA monitor. The video DAC converts the digital color information from the LCD to analog; these analog signals drive the RGB color lines on the VGA port on the rear panel.

A17 CRT Display Driver (E-series)

The line generators on the A2 assembly drive the A17 CRT driver. The A17 assembly contains X and Y deflection amplifiers, focus and intensity grid amplifiers, and miscellaneous CRT bias circuitry. The high voltage is supplied by A6A1 high voltage module.

In fast-analog zero-span mode (sweep times ≤ 30 ms without Option 007), the 0-SPAN VIDEO signal from A3 and the sweep ramp from A14 connects to the A17 CRT driver. The graticule and annotation are still digitally drawn.

Figure 6-8 **Simplified Block Diagram**

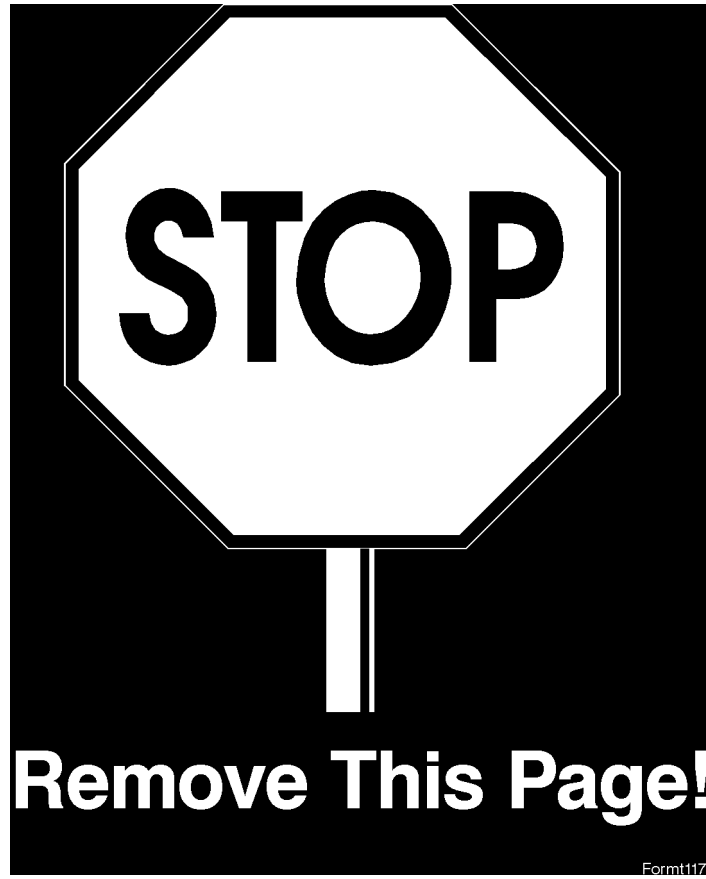

Replace with sj13c

General Troubleshooting
Block Diagram Description

Figure 6-9 Overall Block Diagram (1 of 5)

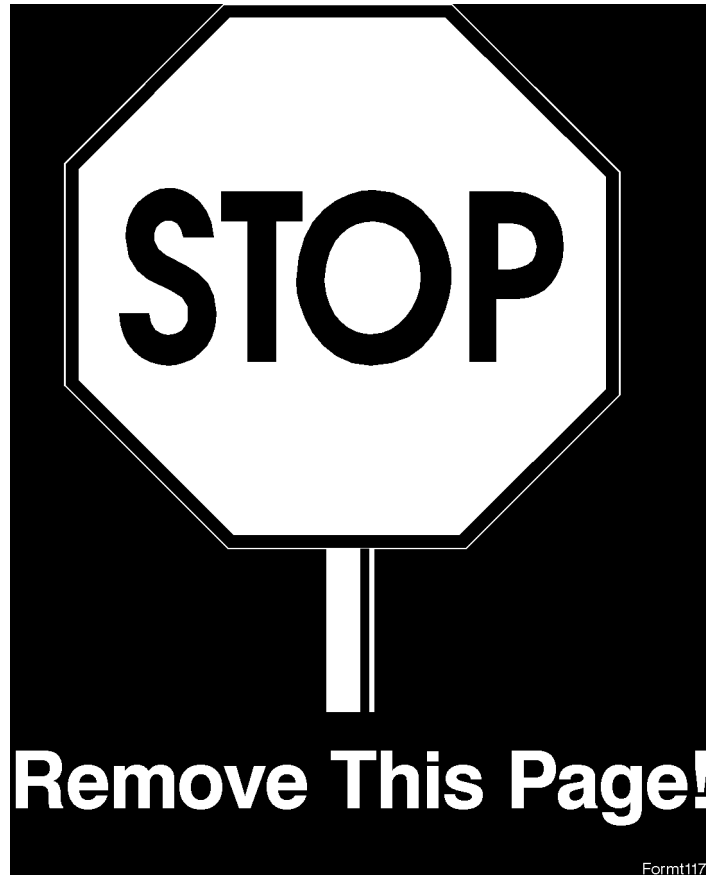

Replace with sj131c

Figure 6-9 Overall Block Diagram (2 of 5)

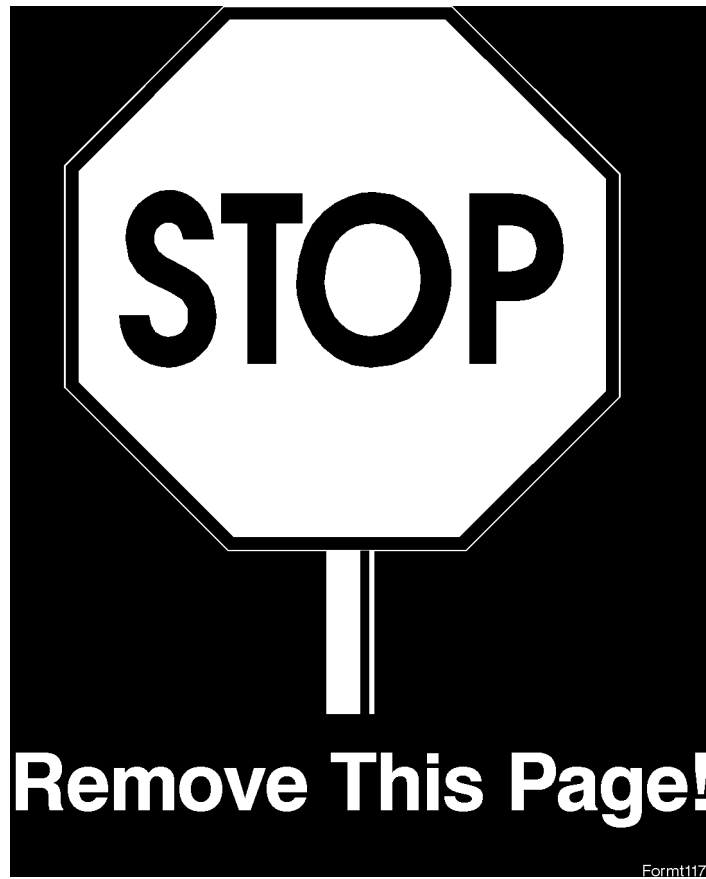

Replace with sj132c

Figure 6-9 Overall Block Diagram (3 of 5)

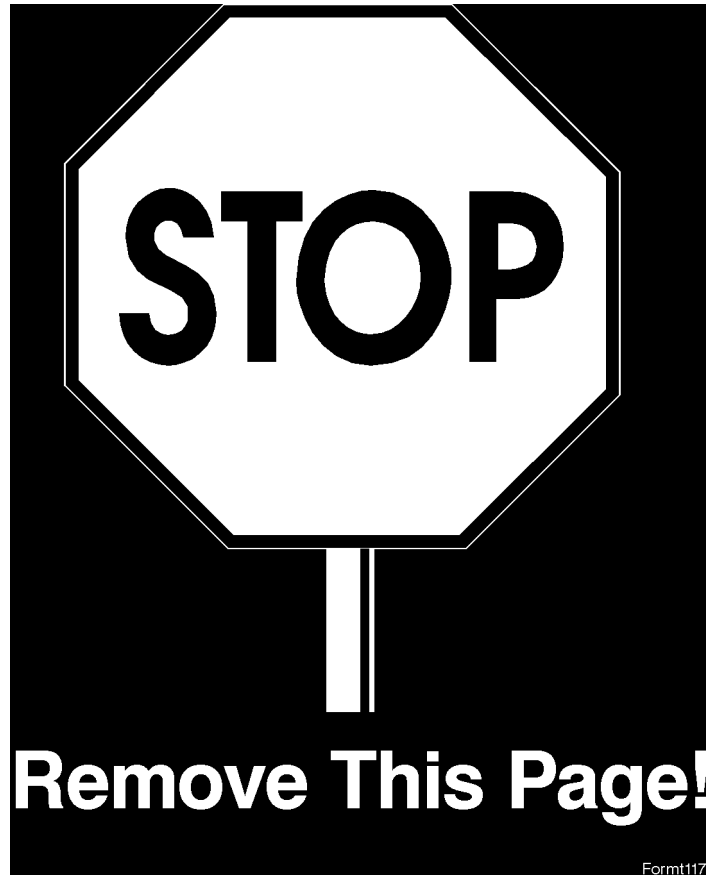

Replace with sj135c

Figure 6-9 Overall Block Diagram (4 of 5)

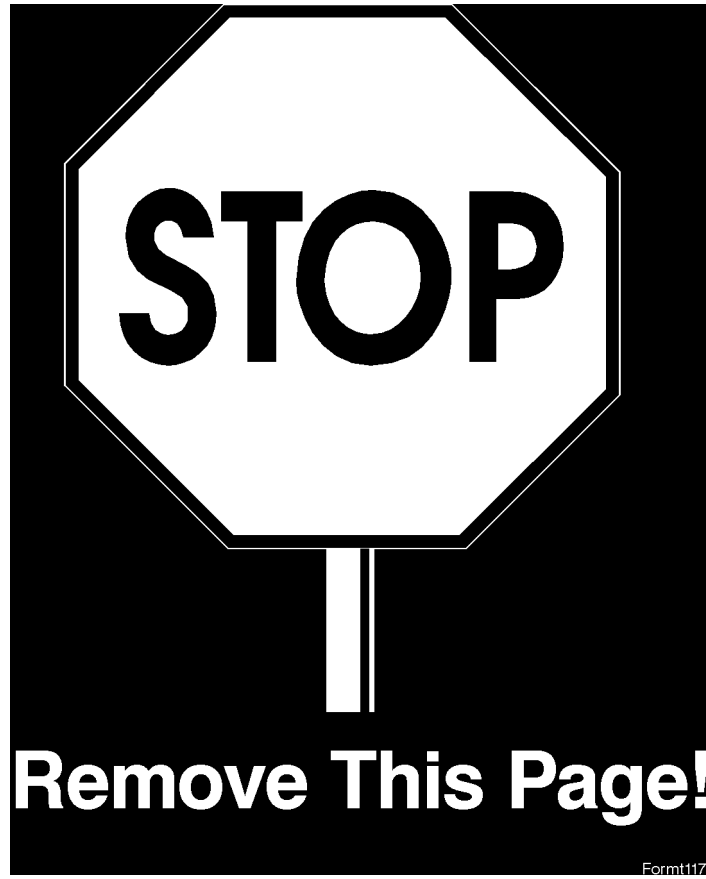

Replace with sj133c

General Troubleshooting
Block Diagram Description

Figure 6-9 Overall Block Diagram (5 of 5)

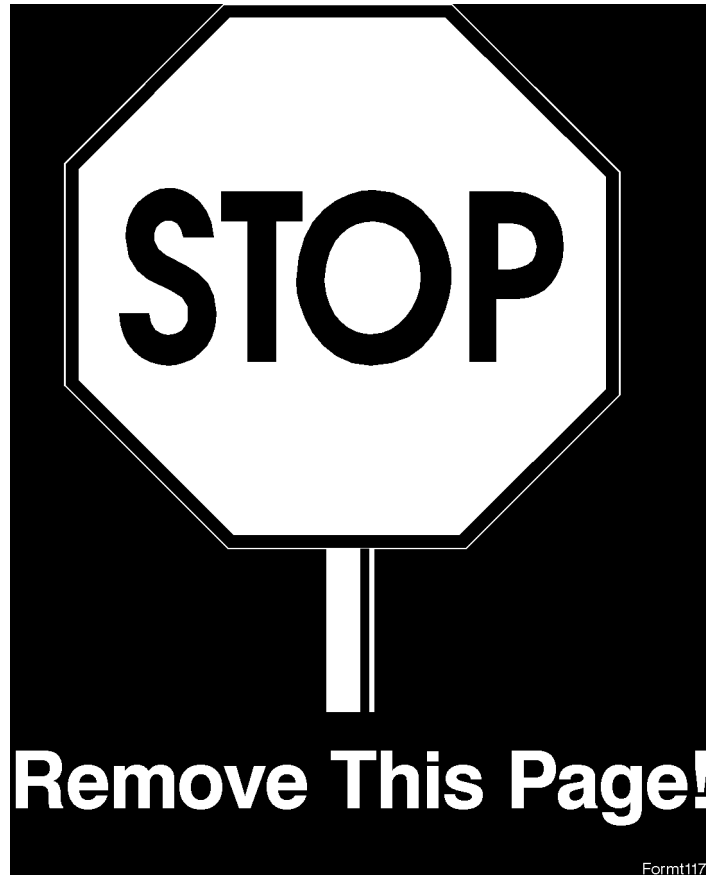

Replace with sj134c

General Troubleshooting
Block Diagram Description

Introduction

The ADC/Interface section includes the A1A1 keyboard, A1A2 RPG (rotary pulse generator), and A3 interface assemblies. In 8560E instruments with option 007, the A16 fast ADC board is also part of the ACD circuitry. For an explanation of fast ADC circuitry in 8560EC instruments see the section on the fast ADC located in chapter 9. [Table 7-1 on page 355](#) lists signal versus pin numbers for control cable W2.

| | |
|---|----------|
| Troubleshooting Using the TAM..... | page 357 |
| Automatic Fault Isolation..... | page 357 |
| Keyboard/RPG Problems | page 360 |
| Keyboard Interface..... | page 360 |
| RPG Interface | page 361 |
| Triggering or Video Gating Problems | page 363 |
| Preselector Peaking Control (Real Time DAC)..... | page 366 |
| Flatness Control (RF Gain DACs)..... | page 367 |
| A3 Assembly Video Circuits | |
| Log Offset/Log Expand | page 371 |
| Video MUX | page 372 |
| Video Filter | page 372 |
| Video Filter Buffer Amplifier..... | page 374 |
| Positive/Negative Peak Detectors..... | page 374 |
| Peak Detector Reset | page 376 |
| Rosenfell Detector | page 377 |
| ADC MUX..... | page 378 |
| Variable Gain Amplifier (VGA) | page 380 |
| Track and Hold..... | page 380 |
| A3 Assembly ADC Circuits..... | page 381 |
| ADC Control Signals..... | page 381 |
| ADC Start/Stop Control..... | page 382 |
| ADC ASM | page 383 |
| ADC..... | page 383 |
| Ramp Counter | page 384 |
| A3 Assembly Control Circuits | page 385 |
| Analog Bus Drivers | page 385 |
| Analog Bus Timing..... | page 386 |
| Interface Strobe Select..... | page 387 |
| A16 Assembly Fast ADC Circuits (Option 007 in the 8560E).... | page 389 |
| Video Input Scaling Amplifiers and Limiter | page 389 |
| 8-Bit Flash ADC | page 390 |
| Peak/Pit Detection..... | page 391 |
| 32 K-Byte Static RAM..... | page 392 |
| A16 Assembly Fast ADC Control Circuits (Option 007 in the 8560E | page 393 |
| CPU Interface and Control Registers | page 393 |
| Reference Clock | page 397 |
| Clock and Sample Rate Generator | page 397 |

Trigger page 398
 16-Bit Post-Trigger Counter page 398
 15-Bit (32 K) Circular Address Counter page 399
 Video Trigger Comparator page 399

Table 7-1 W2 Control Cable Connections

| Signal | A3J2 (pins) | A4J2 (pins) | A5J2 (pins) | A14J2 (pins) | A15J2 (pins) |
|-----------------|-------------|-------------|-------------|--------------|--------------|
| D0 | 1* | 1 | 50 | 1 | 1 |
| D GND | 2* | 2 | 49 | 2 | 2 |
| D1 | 3* | 3 | 48 | 3 | 3 |
| D2 | 4* | 4 | 47 | 4 | 4 |
| D3 | 5* | 5 | 46 | 5 | 5 |
| D4 | 6* | 6 | 45 | 6 | 6 |
| D GND | 7* | 7 | 44 | 7 | 7 |
| D5 | 8* | 8 | 43 | 8 | 8 |
| D6 | 9* | 9 | 42 | 9 | 9 |
| D7 | 10* | 10 | 41 | 10 | 10 |
| A0 | 11* | 11 | 40 | 11 | 11 |
| D GND | 12* | 12 | 39 | 12 | 12 |
| A1 | 13* | — | 38 | 13 | 13 |
| A2 | 14* | — | 37 | 14 | 14 |
| A3 | 15* | 15 | 36 | 15 | 15 |
| A4 | 16* | — | 35 | 16 | 16 |
| D GND | 17* | 17 | 34 | 17 | 17 |
| A5 | 18* | — | 33 | 18 | — |
| A6 | 19* | — | 32 | — | — |
| A7 | 20* | — | 31 | 20 | — |
| D GND | 21* | 21 | 30 | 21 | 21 |
| LRF_STB | 22* | — | — | — | 22 |
| LFC_STB | 23* | — | — | 23 | — |
| LIF_STB | 24* | — | 27 | — | — |
| CAL OSC TUNE | 25 | 25* | — | — | — |
| LLOG_STB | 26* | 26 | — | — | — |
| VCMON | — | — | — | 27 | — |
| D GND | 28* | 28 | 23 | 28 | 28 |
| RT PULSE | 29* | — | — | — | — |
| HSCAN | 30* | — | — | 30 | — |
| D GND | 31* | 31 | 20 | 31 | 31 |
| RESERVED | — | — | — | — | — |
| OFL ERR | 33 | — | — | — | 33* |
| R/T DAC3 | 34* | — | — | — | — |

Table 7-1 W2 Control Cable Connections

| Signal | A3J2 (pins) | A4J2 (pins) | A5J2 (pins) | A14J2 (pins) | A15J2 (pins) |
|----------------------------|-------------|-------------|-------------|--------------|--------------|
| A GND | 35* | 35 | 16 | 35 | 35 |
| RF GAIN | 36* | — | — | — | 36 |
| LO3 ERR | — | — | — | 37 | 37* |
| A GND | 38* | 38 | 13 | 38 | 38 |
| LVFC_ ENABLE | 39* | — | — | 39 | — |
| FC ERR | 40 | — | — | 40* | — |
| A GND | 41* | 41 | 10 | 41 | 41 |
| YTO ERR | 42 | — | — | 42* | — |
| +10V REF | 43* | 43 | — | — | 43 |
| A GND | 44* | 44 | 7 | 44 | 44 |
| SCAN RAMP | 45 | — | — | 45* | — |
| VIDEO TRIGGER | 46* | — | — | — | — |
| A GND | 47* | 47 | 4 | 47 | 47 |
| NC | — | — | — | — | — |
| R/T DAC2 | 49* | — | — | — | — |
| R/T DAC1 | 50* | — | — | 50 | — |
| * Indicates signal source. | | | | | |

Troubleshooting Using the TAM

When using Automatic Fault Isolation, the TAM indicates suspected circuits that need to be manually checked. Use [Table 7-2 on page 358](#) to locate the manual procedure.

[Table 7-3 on page 359](#) lists assembly test connectors associated with each Manual Probe Troubleshooting test. [Figure 7-1 on page 357](#) illustrates the location of A3 test connectors.

Figure 7-1 **A3 Test Connectors**

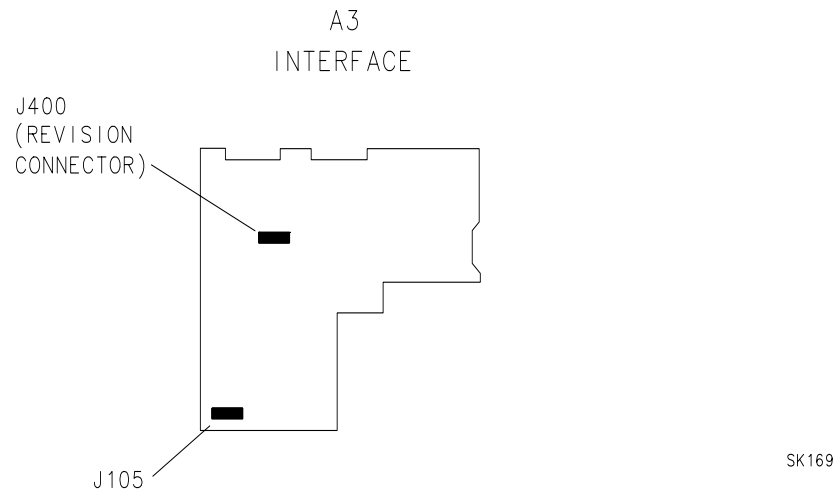

Automatic Fault Isolation

Analog data bus errors that occur during Automatic Fault Isolation result from either a shorted W2 control cable or faulty A3 assembly. Perform the following steps to determine the cause of the error:

1. Disconnect W2 from A3J2 and repeat the Automatic Fault Isolation procedure.
2. If the analog data bus error is still present, troubleshoot the A3 Interface assembly. If the error disappears, look for a short on W2 or another assembly connecting to it.
3. To isolate a short on W2, reconnect W2 to A3J2 and disconnect W2 from all other assemblies.
4. Repeat the Automatic Fault Isolation routine.
5. If the analog data bus error is still present, W2 is shorted. If the error disappears, reconnect the other assemblies one at a time and repeat the procedure. Once the faulty assembly is reconnected to W2, the error should reappear.

Table 7-2 Automatic Fault Isolation References

| Suspected Circuit Indicated by Automatic Fault Isolation | Manual Procedure to Perform |
|---|--|
| Check ADC ASM | ADC ASM |
| Check ADC MUX | ADC MUX |
| Check ADC Start/Stop Control | ADC Start/Stop Control |
| Check Analog Bus Drivers | Automatic Fault Isolation (<i>in this chapter</i>) Analog Bus Drivers |
| Check Analog Bus Timing | Automatic Fault Isolation (<i>in this chapter</i>) Analog Bus Timing |
| Check Interface Strobe Select | Interface Strobe Select |
| Check Keyboard Interface | Keyboard/RPG Problems |
| Check Negative Peak Detector | Positive/Negative Peak Detectors (<i>steps 3 through 10</i>) |
| Check Peak Detector Reset | Peak Detector Reset |
| Check Positive Peak Detector | Positive/Negative Peak Detectors (<i>steps 3 through 10</i>) |
| Check Real Time DAC | Preselector Peaking Control (Real Time DAC) |
| Check Ramp Counter | Ramp Counter |
| Check RF Gain DACs | Band Flatness Control (RF Gain DACs) |
| Check Rosenfell Detector | Rosenfell Detector |
| Check RPG Interface | Keyboard/RPG Problems |
| Check Track and Hold | Track and Hold |
| Check Trigger | Triggering Problems |
| Check Variable Gain Amplifier (VGA) | Variable Gain Amplifier (VGA) |
| Check Video Filter | Video Filter |
| Check Video Filter Buffer Amplifier | Video Filter Buffer Amplifier |
| Check Video MUX | Video MUX |

Table 7-3 TAM Tests versus A3 Test Connectors

| Connector | Manual Probe Troubleshooting Test | Measured Signal Lines |
|------------------|--|------------------------------|
| A3J105 | Video Input to Interface | MS1 |
| | Video to Rear Panel | MS1, MS2 |
| | Video MUX | MS1, MS3 |
| | LOG Offset/LOG Expand | MS1, MS3 |
| | Video Filter Buffer Amp. | MS3, MS5, OS1 |
| | Video Peak Detectors | MS5, MS6 |
| | ADC MUX | MS6 |
| | Variable Gain Amplifier | MS6, MS7 |
| | Track and Hold | MS7, MS8 |
| A3J400 | Revision | MS2 |
| | Trigger | MS8 |
| | ADC Start/Stop Control | MS7 |
| | Video Trigger DAC | MS1 |
| | Real Time DAC #1 | MS3 |
| | RF Gain DACs | MS6 |

Keyboard/RPG Problems

Keyboard Interface

Refer to function block G of A3 Interface Assembly Schematic Diagram (sheet 3 of 6) in the *HP 8560 E-Series Spectrum Analyzer Component Level Information*.

A pressed key results in a low on a keyboard sense line (LKSNS0 through LKSNS7). This sets the output of NAND gate U607 high, generating KBD/RPG_IRQ. The CPU determines the key pressed by setting only one keyboard scan line (LKSCN0 through LKSCN5) low through U602 and reading the keyboard sense lines.

1. If none of the keys or RPG responds, check ribbon cable, A1A1W1. (This cable connects the A1A1 keyboard to the A3 interface assembly.) The keys are arranged in a row/column matrix, as shown in [Table 7-4 on page 360](#).
2. If an entire row or column of keys does not respond, and the RPG does respond, there might be an open or shorted wire in A1A1W1.

Table 7-4

Keyboard Matrix

| | LKSNS0 | LKSNS1 | LKSNS2 | LKSNS3 | LKSNS4 | LKSNS5 | LKSNS6 | LKSNS7 |
|--------|-------------|-------------|--------|---------|--------|-------------|--------|-------------|
| LKSCN0 | CONFIG | SAVE | RECALL | GHz | MHz | kHz | Hz | PRESET |
| LKSCN1 | MODULE | TRIG | DISP | 9 | 6 | 3 | BK SP | ↑ |
| LKSCN2 | PEAK SEARCH | BW | TRACE | 8 | 5 | 2 | • | ↓ |
| LKSCN3 | FREQ COUNT | AUTO COUPLE | MKR → | 7 | 4 | 1 | 0 | HOLD |
| LKSCN4 | SWEEP | SK1 | SK2 | SK3 | SK4 | SK5 | SK6 | MKR |
| LKSCN5 | AUX CTRL | MEAS/ USER | CAL | SGL SWP | COPY | FRE- QUENCY | SPAN | AMPLI- TUDE |

3. Check that all inputs to NAND gate A3U607 (LKSNS lines) are high when no key is pressed. If any input is low, continue with the following:
 - a. Disconnect A1A1W1 from A3J602 and again check all inputs to U607.
 - b. If any input is low with A1A1W1 disconnected, suspect A3U604, A3U607, or A3U602.
 - c. Reconnect A1A1W1 to A3J602.
4. Monitor A3U607 pin 8 with a logic probe. A TTL high should be present when any key is held down. Monitor this point while pressing each key in succession.

5. Check that the LKSCN lines (outputs of A3J602 pins 1 through 6) read a TTL low with no key pressed. (Any TTL high indicates a faulty A3 Interface assembly.)
6. Check that a pulse is present at each LKSCN output of U602 when a key is pressed.
7. Check that only one input to U607 (LKSNS lines) goes low when a key is pressed.
8. Check that U602 pin 9 (LKBD_RESET) pulses low when a key is pressed.
9. If LKBD_RESET is incorrect and a pulse is not present at each of the LKSCN outputs of U602 when a key is pressed, check for LWRCLK and LSCAN_KBD.

RPG Interface

Refer to function block J of A3 Interface Assembly Schematic Diagram (sheet 3 of 6) in the *HP 8560 E-Series Spectrum Analyzer Component Level Information*.

U608B latches the RPG direction from the two RPG outputs, RPG_COUNT and RPG_COUNT1. Counterclockwise RPG rotation produces low-going pulses which result in a high output on U608B. Clockwise RPG rotation results in a low output from U608B. U612A provides the edge to trigger one-shot U423B, which generates a 90 ms pulse. This pulse gates U610A for counting of RPG pulses by U606. Gates U610D and U614D prevent retriggering of U423B until its 90 ms pulse has timed out.

NOTE

Elsewhere, RPG_COUNT1 is referred to as RPG_01 and RPG_COUNT is referred to as RPG_02.

1. Monitor A3U401 pin 2 with a logic probe or oscilloscope. Pulses should be present as the RPG is rotated.
2. Monitor A3U608 pin 12 as the RPG is rotated. Pulses should be present.
3. If pulses are missing at both points, check for power and ground signals to A1A1W1 and A1A2W1. If both power and ground are there, the A1A2 RPG is probably defective.
4. If pulses are missing at only one point, check for an open or short on A1A1W1 and A1A2W1. If these cables are working properly, A1A2 RPG is probably defective.
5. Press **LINE** to turn spectrum analyzer off and disconnect A1A1W1 from A3J602. Jumper A3U608 pin 12 (RPG_COUNT) to U608 pin 14 (+5 Vdc). Jumper U401 pin 2 (RPG_COUNT1) to U511 pin 11 (HDPKD_CLK). This provides a 7.8 kHz square wave to the

RPG_COUNT1 input of the RPG Interface.

6. Press **LINE** to turn spectrum analyzer on.
7. Check A3U608 pin 9 for narrow, low-going pulses approximately every 90 ms.
8. Check A3U608 pin 13 (LRPG_RESET) for narrow, low-going pulses approximately every 90 ms.
9. Check A3U612 pin 5 for narrow, low-going pulses approximately every 90 ms.
10. Check U608 pin 5 (HRPG_IRQ) for narrow, high-going pulses approximately every 90 ms.
11. If HRPG_IRQ is correct but LRPG_RESET is incorrect, check U505 pin 13 (LKBD/RPG_IRQ) for narrow, low-going pulses approximately every 90 ms.
12. If HRPG_IRQ and LKBD/RPG_IRQ are correct but LRPG_RESET is incorrect, suspect a failure on the A2 controller assembly.
13. Check U610 pin 3 for a 7.8 kHz square wave. Check U606 pin 2 (HRPG_RESET) for narrow, high-going pulses approximately every 90 ms. Refer to [Table 7-5 on page 362](#) and check the frequencies at divide-by-16 counter A3U606.
14. If all the checks above are correct but the spectrum analyzer does not respond to the RPG, suspect a problem in either the A1A2 RPG or the A1A1 Keyboard.
15. Press **LINE** to turn spectrum analyzer off.
16. Reconnect A1A1W1 to A3J602 and remove all jumpers.

Table 7-5

Counter Frequencies

| A3U606 pin # | Nominal Frequency (Hz) |
|---------------------|-------------------------------|
| 3 | 3900 |
| 4 | 1950 |
| 5 | 975 |
| 6 | 488 |
| 11 | 244 |
| 10 | 122 |
| 9 | 61 |

Triggering or Video Gating Problems

Refer to function block H of A3 Interface Assembly Schematic Diagram (sheet 3 of 6) in the *HP 8560 E-Series Spectrum Analyzer Component Level Information*.

The 1 MHz ADC clock provides synchronization in FREE RUN and SINGLE triggering. LINE triggering synchronization originates on the A6 power supply. Trigger MUX A3U613 selects between FREE RUN, VIDEO, LINE, and EXTERNAL trigger sources. The trigger signal sets the output of the HSCAN latch high. HBADC_CLK0 provides the trigger signal for FREE RUN. The VIDEO TRIG signal must be at least 25 mV (0.25 divisions) peak-to-peak to trigger in video trigger mode.

The trigger for Gated Video has two modes of operation, level mode and edge mode. In the edge mode, positive-edge or negative-edge triggering can be selected. Output 0 from pin 10 of A3U617 generates the gate delay and output 1 from pin 13 of A3U617 generates the gate length. The duration of these two time intervals is set using front panel softkeys under the SWEEP key. The trigger input for Gated Video is the rear panel EXT/GATE TRIG INPUT (TTL > 10 kΩ).

1. Check that the trigger MUX is receiving the proper trigger source information by selecting each of the following trigger modes and checking the TRIG_SOURCE0 and TRIG_SOURCE1 lines as indicated in [Table 7-6 on page 363](#).
2. If a trigger mode does not work, check that a trigger signal is present at the appropriate trigger MUX input, as indicated in [Table 7-6 on page 363](#).

Table 7-6 Trigger MUX Truth Table

| Trigger Mode | TRIG_SOU RCE0 U613 pin 14 | TRIG_SOU RCE1 U613 pin 2 | MUX Input Pin Number U613 |
|--------------|---------------------------------|--------------------------------|------------------------------------|
| FREE RUN | L | L | 6 |
| VIDEO | H | L | 5 |
| LINE | H | H | 3 |
| EXTERNAL | L | H | 4 |

3. Check that the appropriate trigger MUX input signal is present at the trigger MUX output (A3U613 pin 7).
4. To check the video trigger level DAC, connect the positive lead of a DVM to A3J400 pin 1, and the negative lead to A3TP4.

5. Press **TRIG** and **VIDEO**.
6. Press the **STEP ▼** key several times while noting the DVM reading and position of the video trigger level on the screen.
7. Check that the voltage displayed on the DVM changes by 1 V for each step of the **VIDEO TRIG LEVEL**.
8. If the voltage changes incorrectly, proceed as follows:
 - a. Check the -10 Vdc reference (A3U409 pin 4).
 - b. While using the front panel knob to adjust the video trigger level, check for the presence of pulses on A3U409 pin 15 (LDAC2).
 - c. While using the front panel knob to adjust the video trigger level, check for the presence of pulses on A3U409 pin 16 (LWRCLK).
 - d. Check that pulses are present on U409 pin 6 (IA0).
9. If the LWRCLK and LDAC2 signals are not correct, refer to "Interface Strobe Select" in this chapter.
10. If correct trigger pulses are present at the trigger MUX output (A3U613 pin 7), but the instrument does not appear to be sweeping, proceed as follows:
 - a. Press **PRESET**, **SWEEP**, and **DLY SWP ON OFF** until **ON** is underlined, then **DLY SWP []** 30 milliseconds.
 - b. Using an oscilloscope, check for activity at pins 1 and 3 of A3U615A.
 - c. If there is activity at pin 1 but not at pin 3 of A3U615A, suspect A3U616 or A3U617.
 - d. If there is activity at pin 1 and pin 3 of A3U615A, suspect A3U615. (Check pin 5 for activity.)
11. If there is a problem with Video Gating, proceed as follows:
 - a. Press **PRESET** and set the HP 8560E/EC as follows:

| | |
|------------------------|---------|
| Center frequency | 300 MHz |
| Span | 0 Hz |
| Sweep time | 150 ms |
 - b. Press **TRIG**, **EXTERNAL**, then **SWEEP** and **GATE ON OFF** until **ON** is underlined.
 - c. Press **GATE DLY []** 10 milliseconds, then press **GATE LEN []** 30 milliseconds.
 - d. Connect a pulse/function generator (such as an HP 8116A) to provide a 5 V peak-to-peak square wave (TTL level) to the HP 8560E/EC rear panel **EXT/GATE TRIG INPUT** and also (using a BNC tee) to the channel 4 input of the oscilloscope (HP 54501A).

- e. Set the pulse/function generator to NORMAL mode with a duty cycle of 50% and a frequency of 10 Hz.
- f. Press the following keys on the oscilloscope:

CLEAR DISPLAY

off frame axes grid highlight grid

connect dots off on highlight on

TRIG

source 1 2 3 4 highlight 4

level 2 V

TIMEBASE

TIMEBASE 50 ms/div

CHAN

CHANNEL 1 2 3 4 off on

CHANNEL 1 on

set V/div to 0.2 V and offset to 0.6 V (10:1 probe used)

CHANNEL 4 on

set V/div to 2 V and offset to 0 V

DISPLAY

DISPLAY norm avg env highlight norm

- g. Using a 10:1 probe connected to channel 1 of the oscilloscope, check for activity at pins 10 and 13 of A3U617.
- h. If either pin (or both) show no activity, check for activity at pin 21 (LTIMER) of A3U617.
- i. If LTIMER is not active, troubleshoot the Interface Strobe Select circuitry (block K).
- j. If there was activity at pins 10 and 13 of A3U617, suspect A3U616.

Preselector Peaking Control (Real Time DAC)

Refer to function block L of A3 Interface Assembly Schematic Diagram (sheet 4 of 6) in the *HP 8560 E-Series Spectrum Analyzer Component Level Information*.

The HP 8560E/EC uses a real-time DAC (R/T DAC1) to peak the preselector.

1. Press **PRESET** on the HP 8560E/EC and set the span to 0 Hz.
2. Connect a positive DVM lead to A3J400 pin 3 and the negative DVM lead to A3TP4.
3. Press **MKR, AUX CTRL, INTERNAL MIXER, and PRESEL MAN ADJ.**
4. Monitor the DVM reading while changing the **PRESELECTOR TUNE** value from 0 to 255. The **PRESELECTOR TUNE** value is the setting of R/T DAC1.
5. Check that the DVM reading increases from 0 to approximately +10 Vdc as R/T DAC1 is set from 0 to 255.
6. If the voltage does not change as described, set the spectrum analyzer to single trigger mode and check the following:
 - a. Check that A3U409B pin 18 is at -10 Vdc.
 - b. Check for the presence of pulses at U409 pin 6 (IA0).
 - c. Check that pulses are present at U409 pin 15 (LDAC2).
 - d. Check that pulses are present at U409 pin 16 (LWRCLK).
7. If the LDAC2 or LWRCLK signals are incorrect, refer to "Interface Strobe Select" in this chapter.

Flatness Control (RF Gain DACs)

Refer to function block M of A3 Interface Assembly Schematic Diagram (sheet 4 of 6) in the *HP 8560 E-Series Spectrum Analyzer Component Level Information*.

RF Gain DACs control the A15 assembly flatness compensation amplifiers. The RF Gain DACs are arranged so that the output of one DAC is the voltage reference for the other DAC. This results in an RF GAIN voltage which is exponentially proportional to the DAC settings. Each DAC is set to the same value. The A15 RF assembly converts the RF GAIN signal to a current for driving the PIN diode attenuators in the Flatness Compensation Amplifiers. The exponentially-varying voltage compensates for the nonlinear resistance-versus-current characteristic of the PIN diodes.

1. Place the WR PROT/WR ENA jumper on the A2 controller assembly in the WR ENA position.
2. Press **CAL**, **MORE 1 OF 2**, **SERVICE CAL DATA**, **FLATNESS**, and **FLATNESS DATA**. Press **NEXT BAND** until "FLATNESS BAND # 0" is displayed.
3. Press the **▲** key until "DATA @ 300 MHz" is displayed. Note the number directly underneath "DATA @ 300 MHz"; this is the RF Gain DAC value.
4. Connect a positive DVM lead to A3J400 pin 13 and the negative DVM lead to A3TP4.
5. Check that the DVM reading increases from near 0 Vdc to between -1.3 and -1.9 Vdc as the RF Gain DAC setting is increased from 0 to 4095.
6. If the DVM readings are incorrect, press **PRESET**, **SGL SWP**, **CAL**, **MORE 1 OF 2**, **SERVICE CAL DATA**, **FLATNESS**, and **FLATNESS DATA**. Press **NEXT BAND** until "FLATNESS BAND # 0" is displayed. Press the **▲** key until "DATA @ 300 MHz" is displayed. Proceed as follows:
 - a. Check the +10 V reference.
 - b. Check for narrow, low-going pulses at A3U417 pin 13 (LWRCLK).
 - c. While rotating the front panel knob, check for narrow, low-going pulses at A3U417 pin 1 (LDAC1) and pin 14 (LDACU1).
 - d. While rotating the front panel knob, check for narrow, low-going pulses at U417 pin 16 (L_IA0) and pin 15 (IA4).
7. If the LWRCLK, LDAC1, or LDACU1 is incorrect, refer to the Interface Strobe Select block in this chapter.

8. Place the WR PROT/ WR ENA jumper on the A2 controller assembly in the WR PROT position. Press **PRESET**.

A3 Assembly Video Circuits

Voltages from A3J101 to the A3 Variable Gain Amplifier correspond (approximately) to on-screen signal levels. (One volt corresponds to the top of the screen and zero volts corresponds to the bottom of the screen.) This is true for both log and linear settings except when the spectrum analyzer is in 1 dB/div or 2 dB/div. In these cases the log expand amplifier is selected, and 1 V corresponds to top-screen and 0.8 or 0.9 V corresponds to bottom-screen. The spectrum analyzer can be set to zero span at the peak of a signal to generate a constant dc voltage in the video circuits during sweeps.

1. Disconnect W26 from A3J101 and W20 from A2J4.
2. Connect W26 to A2J4.
3. Set the HP 8560E/EC to the following settings:

| | |
|----------------------------|-----------|
| Span | 0 Hz |
| Sweep time | 20 ms |
| Resolution bandwidth | 1 MHz |
| Log/division | 10 dB/div |
4. If a trace is displayed, troubleshoot the A3 assembly. If a trace is absent, connect an oscilloscope to the rear panel BLKG/GATE OUTPUT.
5. The presence of a TTL signal (TTL low during 20 ms sweep) indicates a good A3 Interface Assembly. Troubleshoot the IF section.
6. If the BLKG/GATE OUTPUT is always at a TTL high or low, troubleshoot the A3 trigger/video gating circuits.
7. Reconnect W26 to A3J101 and W20 to A2J4.
8. Remove the A3 assembly shield.
9. If the video filters appear faulty, see "Video Filter" in this chapter.
10. If there appears to be a peak detector problem, refer to "Positive/Negative Peak Detectors" in this chapter.
11. Connect CAL OUTPUT to INPUT 50 Ω of the HP 8560E/EC, and set the controls as follows:

| | |
|------------------------|---------|
| Center frequency | 300 MHz |
| Span | 0 Hz |
| Reference level | -10 dBm |
12. If the spectrum analyzer works correctly in 5 dB/div and 10 dB/div but not in 1 dB/div or 2 dB/div, refer to "Log Offset/Log Expand" in this chapter. Continue with step 13 if the problem involves on-screen amplitude errors which appear to originate in the video chain.

13. Press **CAL** and **IF ADJ ON OFF** until **OFF** is underlined. Monitor A3TP9 with an oscilloscope. If the voltage is not approximately +1 Vdc, troubleshoot the Log Amplifier on A4. (Refer to the IF troubleshooting procedure in Chapter 8.)
14. To confirm proper video input to the video circuit, set the HP 8560E/EC to Log 10 dB per division and change the reference level in 10 dB steps from -10 dBm to +30 dBm. At each 10 dB step, the input voltage should change 100 mV. The input level should be +0.6 Vdc for a +30 dBm reference level.

NOTE

The on-screen amplitude level will probably not change as expected, since the video circuitry is assumed to be faulty.

15. Monitor A3TP14 while stepping the reference level from -10 dBm to +30 dBm. If the voltage does not step approximately 100 mV per 10 dB step, refer to "Video MUX" in this chapter.
16. If the Video MUX is working properly, monitor A3TP15 with the oscilloscope and step the reference level from -10 dBm to +30 dBm. If the voltage does not change 100 mV per 10 dB step, refer to "Video Filter" in this chapter.
17. If the voltage at A3TP15 is correct, move the oscilloscope probe to A3TP17 and step the reference level between -10 dBm and +30 dBm. If the voltage does not change 100 mV per 10 dB step, refer to "Video Filter Buffer Amplifier" in this chapter.
18. If the voltage at A3TP17 is correct, move the oscilloscope probe to A3TP6. Set the following controls to keep the ADC MUX set to the MOD_VIDEO input during the sweep.

SWEEP TIME 50 s
DETECTOR MODE SAMPLE

19. Step the reference level from -10 dBm to +30 dBm while monitoring the voltage change on the oscilloscope. If the voltage does not change 100 mV per 10 dB step, refer to "ADC MUX" in this chapter.
20. If the voltage at A3TP6 is correct, move the oscilloscope probe to A3TP8 and step the reference level between -10 dBm and +30 dBm. If the voltage at A3TP8 is not the same as that at A3TP6, replace A3U110.
21. If the voltage at A3TP8 and A3TP6 are equal, move the oscilloscope probe to A3TP7.
22. Change the reference level from -10 dBm to 0 dBm. The voltage change on A3TP7 should be between 630 mV and 770 mV. If the voltage change is outside of these limits, refer to "Variable Gain Amplifier (VGA)" in this chapter. The gain of the VGA should be $7 \pm 10\%$.

Log Offset/Log Expand

Refer to function block X of A3 Interface Assembly Schematic Diagram (sheet 5 of 6) in the *HP 8560 E-Series Spectrum Analyzer Component Level Information*.

The log scales are modified using a combination of amplification and digital trace manipulation. The video input to the A3 assembly is either 10 dB/div or linear. To obtain the 5 dB/div scale, the CPU manipulates the trace data from the 10 dB/div scale. To obtain the 2 dB/div scale, the video signal is amplified and offset so that top-screen in 10 dB/div corresponds to top-screen in 2 dB/div. To obtain the 1 dB/div scale, the CPU manipulates trace data from the 2 dB/div scale.

In 2 dB/div, Log Offset/Log Expand amplifies the top 20 dB of the display. This is done by offsetting the video signal by -0.8 V and providing a gain of 5 to the top 0.2 V of the video signal. The -0.8 V offset is accomplished by sinking 2 mA through R114 by current source U105/Q101.

1. On the HP 8560E/EC, press **PRESET**, **SPAN**, **ZERO SPAN**, **CAL**, and **IF ADJ OFF**.

2. Disconnect W26 (coax 2) from A3J101 and connect the output of a function generator to A3J101.

3. Set the function generator to the following settings:

Output Sine wave
Amplitude 1 V pk-to-pk
DC Offset +500 mV
Frequency 50 Hz

4. Set the HP 8560E/EC sweep time to 50 ms.

5. Adjust the function generator amplitude and offset until the sine wave fills the entire graticule area.

6. Measure and note the function generator peak-to-peak voltage using an oscilloscope.

$$V_{(10 \text{ dB/div})} = \underline{\hspace{2cm}} \text{ V}$$

7. Set the HP 8560E/EC to 2 dB/div.

8. Readjust the function generator amplitude and offset until the sine wave again fills the entire graticule area.

9. Measure the function generator peak-to-peak voltage and dc offset.

$$V_{(2 \text{ dB/div})} = \underline{\hspace{2cm}} \text{ V}$$

10. The ratio of voltage recorded in step 6 to the voltage recorded in step 9 should be $5 \pm 3\%$. If the ratio is not 5, troubleshoot the A3 assembly.

11. Reconnect W26 to A3J101.

Video MUX

Refer to function block U of A3 Interface Assembly Schematic Diagram (sheet 5 of 6) in the *HP 8560 E-Series Spectrum Analyzer Component Level Information*.

1. Press **PRESET** and set the HP 8560E/EC controls as follows:
Center frequency 300 MHz
Span 0 Hz
2. Press **SGL SWP**, **CAL**, and **IF ADJ OFF**. Connect the CAL OUTPUT to the INPUT 50 Ω connector.
3. Check for a TTL high on A3U104 pin 2 and a TTL low on U104 pin 10. Set the spectrum analyzer to 2 dB/div and check for a TTL high on A3U104 pin 10 and a TTL low on A3U104 pin 2.
4. If the logic levels on A3U104 are incorrect, check the LLOG_STB signal as follows:
 - a. Monitor A3U104 pin 9 with an oscilloscope or logic probe. Check that a 1 microsecond, low-going pulse is present when switching between 10 dB/div and 2 dB/div.
 - b. Check the inputs to A3U104 (pins 3 and 11) while switching between 10 dB/div and 2 dB/div.
 - c. If the logic signals are incorrect, refer to "Analog Bus Timing" and "Analog Bus Drivers" in this chapter.
5. Check comparators A3U109A/C for proper outputs. The outputs should be high when the noninverting input is greater than the threshold voltage of +1.3 Vdc.
6. If A3U104 and A3U109 are working properly, set the **AMPLITUDE** and **REF LVL** to 0 dBm.
7. Monitor the voltage at A3TP14 while switching the spectrum analyzer between 10 dB/div and 2 dB/div. The voltage should switch between 0.8 and 0.4 Vdc.
8. If the voltage at A3TP14 is incorrect, suspect either A3Q220 or A3Q221.
9. The Video MUX will appear faulty if A3CR109 is shorted or leaky. Diode A3CR109 clamps the voltage at A3TP14 to -0.4 V when in log expand, with less than 0.8 V at J101. To confirm this failure, lift the cathode of diode A3CR109 and repeat steps 1 through 7.
10. To return the HP 8560E/EC to automatic sweep, press **SWEEP**, **SWEEPCONT SGL** or press **PRESET**.

Video Filter

Refer to function block V of A3 Interface Assembly Schematic

Diagram (sheet 5 of 6) in the *HP 8560 E-Series Spectrum Analyzer Component Level Information*.

The HP 8560E/EC uses digital filtering for 1 Hz to 100 Hz video bandwidths. An RC low-pass filter is used for 300 Hz to 3 MHz video bandwidths. Various series resistances and shunt capacitances switch into the video filter to change its cutoff frequency.

When Gated Video is selected, the video signal is "gated" (turned on periodically for a set duration of time). This function is shown in block V of the block diagram as a series switch that allows the video signal to pass only when it is closed. The actual switch, U109B/CR118, shunts the video to ground (video signal is passed only when the switch is open). The control circuitry for this switch is described under "Triggering or Video Gating Problems" in this chapter. The rear panel EXT/GATE TRIG INPUT provides the connection for triggering in the Gated Video mode. The gate output signal is available at the rear panel BLKG/GATE OUTPUT connector. Positive or negative edge mode, or level mode can be selected from the front panel.

1. Press **PRESET** and set the HP 8560E/EC controls to the following settings:

| | |
|------------------------|-----------------|
| Center frequency | 225 MHz |
| Span | 550 MHz |
| Sweep time | Uncoupled (MAN) |

2. Press **CAL** and **IF ADJ OFF**.
3. Step the Video BW from 3 MHz to 10 kHz. At each step, the peak-to-peak deviation of the noise should decrease.
4. Step the Video BW down to 1 Hz. At each step, the amplitude of the LO feedthrough should decrease.
5. Refer to [Table 7-7 on page 374](#) and check for correct latched levels for the selected video bandwidth setting.
6. If the output of latch A3U102 is not correct, trigger an oscilloscope on LLOG_STB (U102 pin 9) and monitor U102 pin 1 and other latch inputs while changing the video bandwidth.
7. If the inputs are incorrect, troubleshoot the analog bus. Correct inputs with bad outputs indicate a faulty U102.
8. Check that the outputs of A3U111A, A3U111B, and A3U107A/B/C/D are correct for their inputs. The outputs should be high with noninverting inputs higher than the +1.4 V threshold voltage. If a voltage drop is noticed across these components, suspect A3CR109 or A3Q317B. Since no dc current flows through any of the series resistances or FETS (drain to source), no voltage drops should occur.
9. To return the HP 8560E/EC to automatic sweep, press **SWEEP**,

SWEEP CONT SGL or PRESET.

Table 7-7

A3U102 Latch Outputs

| Video BW | Pin 2 | Pin 5 | Pin 7 | Pin 10 | Pin 12 | Pin 15 |
|-----------------|--------------|--------------|--------------|---------------|---------------|---------------|
| 300 Hz | H | L | L | L | L | L |
| 1 kHz | L | L | L | L | L | H |
| 3 kHz | L | H | L | L | L | L |
| 10 kHz | L | L | L | L | H | L |
| 30 kHz | H | L | H | L | L | L |
| 100 kHz | L | L | H | L | L | H |
| 300 kHz | L | H | H | L | L | L |
| 1 MHz | L | L | H | L | H | L |
| 3 MHz | L | L | L | H | L | L |

Video Filter Buffer Amplifier

Refer to function block W of A3 Interface Assembly Schematic Diagram (sheet 5 of 6) in the *HP 8560 E-Series Spectrum Analyzer Component Level Information*.

The video filter buffer amplifier provides outputs for video trigger, positive and negative peak detectors, and the analog zero-span (sweeps <30 ms). The zero-span video output is terminated in 500 ohms on the A2 Controller assembly. The amplifier is a high-input-impedance buffer amplifier with a gain of one when properly terminated.

Current source U307C provides twice the current of Q316. Resistor R145 and current source U307D shift the dc level. Resistor R260 terminates the peak detector inputs in 500 ohms. The unterminated gain is 1.1. Diode CR114 prevents latchup during positive overdrive conditions while CR113 protects Q318 during overdrive. Diode CR117 is a 12.7 V zener that limits the peak detector output to +1.5 V. Typically, limiting occurs at +1.1 V.

Positive/Negative Peak Detectors

Refer to function blocks Y and Z of A3 Interface Assembly Schematic Diagram (sheet 5 of 6) in the *HP 8560 E-Series Spectrum Analyzer Component Level Information*.

The following information pertains to the positive peak detector and is applicable to troubleshooting the negative peak detector.

The positive peak detector consists of an input amplifier (A3U204 and

A3Q210) followed by detector diodes (A3CR203 and A3CR204) and hold capacitor A3C217. Output amplifier A3Q206, Q211, and Q212 buffers the hold capacitor. Both the input and output amplifiers have a gain of one. Each amplifier has local feedback. On the output amplifier, the emitter of Q212 connects to the gate of Q206. On the input amplifier the feedback goes through Q209 and Q208 back to the base of U204D. Global feedback occurs from the output amplifier through R223 back to the input amplifier U204D. The peak detector resets through Q207.

1. Press **PRESET** and set the HP 8560E/EC controls as follows:

| | |
|----------------------------|-----------|
| Center frequency | 300 MHz |
| Span | 500 MHz |
| Resolution bandwidth | AUTO |
| Video bandwidth | AUTO |
| Log dB/division | 10 dB/div |

2. If the HP 8560E/EC does not meet the conditions in steps a through e below, the positive and negative peak detectors are probably faulty. Continue with step 3 to check the detectors.

- a. The peak-to-peak deviation of the noise in **NORMAL** detector mode should be approximately two divisions. Press **TRACE**, **TRACE B**, **CLEAR WRITE B**, **VIEW B**, **TRACE A**, **MORE 1 of 3**, and **DETECTOR MODES**.
- b. Select **DETECTOR POS PEAK** mode.
- c. Confirm that the noise is about one-third division peak-to-peak. The noise should also be no higher than the top of the noise level in **NORMAL** detector mode.
- d. Select **DETECTOR NEG PEAK** mode. The noise should be about one-third of a division peak-to-peak. The noise should also be no lower than the bottom of the noise in **NORMAL** mode.
- e. Select **DETECTOR SAMPLE** mode. Check that the noise appears between the top and bottom of the noise in **NORMAL** mode.

3. On the HP 8560E/EC, connect the front panel **CAL OUTPUT** to the **INPUT 50 Ω** and set the controls to the following settings:

| | |
|------------------------|----------|
| Center frequency | 300 MHz |
| Span | 0 Hz |
| Sweep time | 5 s |
| Detector mode | POS PEAK |

4. Monitor A3TP17 and A3TP16 simultaneously with an oscilloscope.
5. Change the reference level from -10 dBm to $+30$ dBm and verify a voltage change at both A3TP17 and A3TP16 of 0.9 V to 0.5 V in 100 mV steps.
6. Check the entire range of the detector by substituting a dc source at J101 and varying its output from 0 V to 1 V.

7. If the peak detector appears latched up, check LPOS_RST (U422 pin 4) for a negative TTL level reset pulses. The reset pulses should occur every 130 μ s and should be approximately 250 ns wide.
8. If the reset pulses are absent, troubleshoot the Peak Detector Reset circuitry.
9. If the reset pulses are present, check the gate of Q207. The pulses should be positive-going from -12.7 V to -1.35 V.
10. The peak detector can be made into a unity gain amplifier by shorting the cathode of CR203 to the anode of CR204. If the peak detector functions normally as a unity gain amplifier, suspect Q208 or CR203 or CR204.

Peak Detector Reset

Refer to function block R of A3 Interface Assembly Schematic Diagram (sheet 4 of 6) in the *HP 8560 E-Series Spectrum Analyzer Component Level Information*.

1. Press **PRESET** on the HP 8560E/EC and set the controls as follows:
Center frequency 300 MHz
Span 0 Hz
Sweep time 5 s
Detector mode POS PEAK
2. Check that HHOLD (A3U526 pin 11) has 18 μ s wide pulses every 128 μ s.
3. Check that HODD (U408 pin 5) is a square wave with a period of 16.7 ms ($2 \times$ sweep time/600).
4. Check LPOS_RST (U422 pin 4) for 200 ns low-going pulses every 128 μ s.
5. Check LNEG_RST (A3U422 pin 12) for 200 ns low-going pulses every 128 μ s.
6. Set the detector mode to NORMAL and check that LNEG_RST (A3U422 pin 12) has two pulses spaced 40 μ s apart and then a single pulse approximately 88 μ s from the second pulse.
7. Check HMUX_SEL0 (A3U408 pin 3) and HMUX_SEL1 (A3U408 pin 9) according to [Table 7-8 on page 377](#).

Table 7-8 HMUX_SELO/1 versus Detector Mode

| Detector Mode | HMUX_SELO (U408 pin 3) | HMUX_SEL1 (U408 pin 9) |
|---------------|------------------------------------|------------------------------------|
| NORMAL | 15 μ s pulse every 128 μ s | 40 μ s pulse every 128 μ s |
| SAMPLE | H | H |
| POS PEAK | H | L |
| NEG PEAK | L | H |

Rosenfell Detector

Refer to function block S of A3 Interface Assembly Schematic Diagram (sheet 4 of 6) in the *HP 8560 E-Series Spectrum Analyzer Component Level Information*.

If both HPOS_HLDNG and HNEG_HLDNG are high during the same bucket, HROSENFELL will also be set high. This indicates that the video signal probably consists of noise, since it rose and fell during the same period. The HROSENFELL signal is valid only when the NORMAL (rosenfell) detector mode is selected.

1. Remove anything connected to the HP 8560E/EC front panel INPUT 50 Ω connector. Press **PRESET** on the HP 8560E/EC and set the controls as follows:

Center frequency 300 MHz
Span 0 Hz
Sweep time 5 s
Detector mode NORMAL

2. Check LPOS_RST and LNEG_RST as described in "Peak Detector Reset."
3. Check A3U423 pin 4 for two low-going 3.3 μ s pulses 40 μ s apart occurring every 130 μ s.
4. Check that HROSENFELL (A3U610 pin 6) has two pulses spaced approximately 40 μ s apart and then a third pulse 60 μ s from the second pulse. Each pulse should be approximately 10 μ s wide and low-going.
5. Monitor HROSENFELL with an oscilloscope while reducing the video bandwidth from 1 MHz to 1 kHz.
6. As the video bandwidth is decreased to 1 kHz, the HROSENFELL line should increasingly show a low logic level. With a video bandwidth of 1 kHz, a nearly flat line should be displayed on the CRT.
7. Set the sweep time to 50 ms. Externally trigger the oscilloscope

using the HP 8560E/EC rear panel BLKG/GATE OUTPUT.

8. Check that HPOS_HLDNG (A3U416 pin 4) is mostly high with a 1 MHz video bandwidth and mostly low with a 1 kHz video bandwidth.
9. Check that HNEG_HLDNG (U416 pin 9) is mostly high with a 1 MHz video bandwidth and mostly low with a 1 kHz video bandwidth.

ADC MUX

Refer to function block AA of A3 Interface Assembly Schematic Diagram (sheet 6 of 6) in the *HP 8560 E-Series Spectrum Analyzer Component Level Information*.

The ADC MUX switches various inputs into the video path for conversion by the ADC. The SCAN RAMP input is used during sweeps having a width of equal to or greater than 2.01 MHz times N, to control the timing of the ADC operations. Some combination of MOD_VIDEO, NEG_PEAK, and POS_PEAK is used for the video signal to be converted by the ADC. The YTO ERR, FCMUX, CAL OSC TUNE, and OFL ERR inputs are used only during diagnostic and auto adjust routines and during retrace.

1. Set the HP 8560E/EC to the following settings:

| | |
|------------------------|---------|
| Center frequency | 300 MHz |
| Span | 0 Hz |
| Reference level | -10 dBm |
| Sweep time | 50 s |
| DETECTOR MODE | SAMPLE |

2. Refer to [Table 7-9 on page 379](#) and check for correct logic levels at A3U108 pins 1, 15, and 16. Check for proper output signals at TP6. If the select lines are not changing, suspect the ADC ASM or the VGA/ADC MUX Control. If the select lines are changing, but the proper video inputs are not being switched to the output, replace U108. In SAMPLE mode, the input is MOD_VIDEO (pin 7); in POS PEAK mode, the input is POS_PEAK (pin 5); and in NEG PEAK mode, the input is NEG_PEAK (pin 6).
3. Check for the presence of the YTO ERR signal at A3J2 pin 42 with an oscilloscope probe.
4. If ERR 300 YTO UNLK or 301 YTO UNLK occurs and the voltage is near zero during a sweep and positive during retrace (YTO is being locked), the fault is on the A3 assembly. If a constant dc voltage is present, refer to the Synthesizer section troubleshooting procedure

in Chapter 10.

Table 7-9 Logic Levels at A3U108

| Detector Mode | U108 pin 1 | U108 pin 15 | U108 pin 16 |
|---------------|------------|-------------|-------------|
| SAMPLE | H | L | H |
| POS PEAK | H | L | L |
| NEG PEAK | L | L | H |

5. Set the HP 8560E/EC to the following settings:

Span 5 MHz
Sweep time 50 ms

6. Check for the presence of the SCAN RAMP signal by connecting an oscilloscope probe to A3J2 pin 45 (component side of A3J2). Connect the negative-probe lead to A3TP4.

7. A 0 to 10 V ramp should be present in both LINE and FREE RUN trigger modes. If the waveform is present only in LINE trigger, ADC control signal HBADC_CLK0 may be faulty. Refer to "ADC Control Signals" in this chapter.

8. If the scan ramp is present, but is not being switched to the output of U108, replace U108. If the scan ramp is absent in either mode, do the following:

- a. Connect the oscilloscope probe to A3J400 pin 15 (HSCAN).
- b. A TTL signal (high during 50 ms sweep time and low during retrace) should be present, indicating A3 is working properly. Refer to the Synthesizer section troubleshooting procedure in Chapter 10. A faulty TTL signal indicates a bad A3 Interface assembly.

9. Set the HP 8560E/EC to the following settings:

Sweep time 100 ms
Span 100 MHz

10. Press **CAL** and **IF ADJ ON** and check for the presence of the CAL OSC TUNE signal by monitoring A3J401 pin 25 with an oscilloscope. If ERR 499 CAL UNLK is displayed and a signal within the range of -10 V to +10 V is present during part of the retrace period, the fault is on the A3 assembly.

11. If a constant dc voltage is present during the sweep and all of the retrace period, refer to the IF Section troubleshooting procedure in Chapter 8.

Variable Gain Amplifier (VGA)

Refer to function block AB of A3 Interface Assembly Schematic Diagram (sheet 6 of 6) in the *HP 8560 E-Series Spectrum Analyzer Component Level Information*.

The VGA provides adjustable gain in the video path. Its nominal gain of 7 can be adjusted $\pm 10\%$. U112 removes dc offset to keep U113 in its monotonic range. (Both U112 and U113 are set to the same value.) The DAC settings cannot be changed from the front panel.

Track and Hold

Refer to function block AC of A3 Interface Assembly Schematic Diagram (sheet 6 of 6) in the *HP 8560 E-Series Spectrum Analyzer Component Level Information*.

1. Press **PRESET** on the HP 8560E/EC and set the controls as follows:

| | |
|------------------------|----------|
| Center frequency | 300 MHz |
| Span | 0 Hz |
| Detector mode | Sample |
| Reference level | -70 dBm |
| Log dB/division | 2 dB/div |
| Sweep time | 50 ms |

2. Disconnect any signal from the spectrum analyzer input. A full scale display of sampled noise should be present.
3. Trigger an oscilloscope on the positive going edge of HHOLD (A3U506 pin 16).
4. The waveform at A3TP10 should be random noise with an average level of approximately 4 V. The noise should have a flat spot in its response while HHOLD is high, indicating proper operation of U114.

A3 Assembly ADC Circuits

The ADC consists of a 12-bit DAC, 12-bit successive approximation register (SAR), data multiplexers, and data latches. The ADC ASM (algorithmic state machine) controls the ADC. Eight inputs are controlled by the ADC MUX. These include a positive peak detector, negative peak detector, sampled video, scan ramp, YTO error voltage, FC MUX voltages, Cal Oscillator tune voltage, and offset lock error voltage. A MUX on the A14 frequency control assembly selects which voltage is sent to the ADC MUX on the FC MUX signal line.

During NORMAL detector mode sweeps, when noise is detected by the rosenfell detector, the ADC ASM automatically switches between POS PEAK and NEG PEAK.

ADC Control Signals

Refer to function blocks B and F of A3 Interface Assembly Schematic Diagram (sheet 2 of 6) in the *HP 8560 E-Series Spectrum Analyzer Component Level Information*.

The ADC requires two signals from the A2 controller assembly: HBADC_CLK0 and HBBKT_PULSE. HBBKT_PULSE is used only in zero span. Use the following steps to verify the signals:

1. Disconnect W22 from A2J8.
2. If a 10 MHz TTL signal is absent on W22, refer to the 10 MHz Reference (on the A15 RF assembly) troubleshooting procedure in Chapter 11.
3. Set the HP 8560E/EC **SPAN** to zero.
4. Reconnect W22.
5. With an oscilloscope probe, monitor A3J401 pin 20.
6. If TTL pulses are absent, the A2 controller assembly is faulty. Refer to Chapter 9. The presence of TTL pulses indicates a faulty A3 assembly.
7. Monitor A3J401 pin 23 (HBADC_CLK0). If a 1 MHz TTL clock signal is present, HBADC_CLK0 is working properly.
8. If HBKT_PULSE or HBADC_CLK0 is missing, disconnect A3W1 from A2J2.
9. Monitor A2U5 pin 3 for HBKT_PULSE and A2U5 pin 7 for HBADC_CLK0.
10. If HBADC_CLK0 is absent, troubleshoot the A2 controller assembly.
11. HBKT_PULSE is absent, refer to the information on troubleshooting

the frequency counter in Chapter 9.

12.Reconnect A3W1 to A2J2.

ADC Start/Stop Control

Refer to function block B of A3 Interface Assembly Schematic Diagram (sheet 2 of 6) in the *HP 8560 E-Series Spectrum Analyzer Component Level Information*.

The ADC Start/Stop Control determines the start time of all ADC conversions. Multiplexer A3U509 chooses the source of the start signal. Both HSTART_SRC and HBUCKET tell the ASM to start a conversion.

1. Press **PRESET** on the HP 8560E/EC and set the following controls:

Span 0 Hz
Sweep time 60 s
Detector mode SAMPLE

2. Check for a TTL high at A3U509 pin 2 and a TTL low at A3U509 pin 14.

3. Set the detector mode to NORMAL.

4. Check that A3U509 pins 2 and 14 are both TTL low.

5. Set the HP 8560E/EC to the following settings:

Span 1 MHz
Detector mode SAMPLE

6. Check for a TTL high at A3U509 pin 2 and a TTL low at A3U509 pin 14.

7. Press **CAL** and **REALIGN LO &IF**. During the realignment, A3U509 pin 2 should be TTL low and pin 14 should be TTL high until the 10 kHz and narrower resolution bandwidths are adjusted. If correct, the Start/Stop Control circuitry is being selected properly by the processor and U508 in the ADC Register block is working properly.

8. Press **PRESET** on the HP 8560E/EC and set the controls as follows:

Span 0 Hz
Detector mode SAMPLE
Sweep time 400 ms

9. Check that A3U509 pin 7 has positive 15 μ s pulses with a 667 μ s period (sweep time/600). Check that A3U509 pin 9 has positive 15 μ s pulses with a 667 μ s period (sweep time/600). The pulses should be present during the sweep but absent during retrace.

10.Set the detector mode to NORMAL.

11.Check that A3U509 pin 9 has pulses every 130 μ s and U509 pin 7 has pulses every 667 μ s (although pulse widths may be changing).

ADC ASM

Refer to function block F of A3 Interface Assembly Schematic Diagram (Sheet 2 of 6) in the *HP 8560 E-Series Spectrum Analyzer Component Level Information*.

1. Press **PRESET** on the HP 8560E/EC and set the controls as follows:
Span 0 Hz
Sweep time 60 s
Detector mode SAMPLE
2. Check that HSTART_SRC (U504 pin 4) goes TTL high, causing HHOLD (U506 pin 16) to go high 15 μ s later.
3. Check that HSTART_ADC (U506 pin 15) goes TTL high 19 μ s after HSTART_SRC goes high.
4. HHOLD should stay TTL high for approximately 18 μ s, and HSTART_ADC should stay high for approximately 31 μ s.
5. Check that LCMPLT (U504 pin 15) goes TTL low 12 μ s after HSTART_ADC goes high (12 bits at 1 μ s per bit). LCMPLT indicates that the successive approximation state machine (SASM) has completed the ADC conversion.
6. Check that LDONE (U506 pin 19) goes TTL low approximately 2 μ s after LCMPLT goes low.

ADC

Refer to function block A of A3 Interface Assembly Schematic Diagram (sheet 2 of 6) in the *HP 8560 E-Series Spectrum Analyzer Component Level Information*.

The successive approximation state machine (SASM) consists of A3U527 and A3U528. Upon the occurrence of HSTART_ADC, the SASM successively toggles bits from high to low starting with the most significant bit. The digital result is then converted to an analog current in DAC U518 and compared with the SAMPLED VIDEO. If the DAC current is too high, the output of U512 will be low, telling the SASM that the "guess" was high and that the bit just toggled should remain low. It then moves on to the next most significant bit until all 12 bits have been "guessed" at. Each "guess" takes 1 μ s (one cycle of HBADC_CLK0), or 12 μ s to complete a conversion. When the conversion is completed, the SASM sets LCMPLT low. The bits are written to the data bus by buffers U514 and U516.

1. Set the HP 8560E/EC controls as follows:

Center frequency 300 MHz
Span 0 Hz
Sweep time 60 s
Detector mode SAMPLE

2. Trigger an oscilloscope on HSTART_ADC (U506 pin 15) and monitor the outputs of the SASM (U527 pins 18 and 19; U528 pins 14 thru 23). Each bit should start high and be switched low. It will either stay low or return to a high state 1 μ s later, depending on the comparison at U512.
3. If the outputs do not exhibit this bit pattern, and the ADC ASM checks are working properly, suspect A3U527, U528, or one of the latches (U514/516). If the output of comparator U512 does not toggle back and forth during a conversion, suspect either U512 or one of the clipping diodes (CR500/CR501).

NOTE

Because currents are being summed at U512 pins 2 and 3, voltage levels at these points are difficult to interpret.

Ramp Counter

Refer to function block D of A3 Interface Assembly Schematic Diagram (sheet 2 of 6) in the *HP 8560 E-Series Spectrum Analyzer Component Level Information*.

The ramp counter is used for sweeps with widths greater than 2.0 MHz times N. The analog sweep ramp is compared to the digital ramp counter. When the analog sweep ramp exceeds the DAC output generated for that ramp counter setting, HRAMP_COMP toggles high, indicating the end of a bucket. The ramp counter counts horizontal buckets. There are 601 buckets per sweep, so the ramp (bucket) counter counts from 0 to 600. The ramp counter is incremented by HRST_PK_ENA.

1. Press **PRESET** on the HP 8560E/EC and set the controls as follows:

Span 5 MHz
Detector mode SAMPLE

2. For spans greater than 2.0 MHz times N0, HODD (A3U525 pin 3) is a square wave with a period defined by $(2 \times \text{sweep time}/600)$. For example, for a 6 s sweep time, HODD has a period of 20 ms. The ramp (bucket) counter will be odd every other bucket.

A3 Assembly Control Circuits

A digital control problem will cause the following three steps to fail:

1. On the HP 8560E/EC, press **AMPLITUDE**, **ATTEN MAN**, **7**, **0**, and **dB**.
2. A click should be heard after pressing **dB** in step 1, unless **ATTEN** was previously set to 70 dB.
3. Press **1**, **0**, and **dB**. Another click should be heard. If no clicks were heard, but the **ATTEN** value displayed on the CRT changed, the digital control signals are not operating properly.

Analog Bus Drivers

Refer to function block N of A3 Interface Assembly Schematic Diagram (sheet 4 of 6) in the *HP 8560 E-Series Spectrum Analyzer Component Level Information*.

1. Press **PRESET** on the HP 8560E/EC, and set the controls as follows:
Span 0 Hz
Trigger Single
2. Monitor A3U401 pin 3 (LRF_STB) with an oscilloscope or logic probe. This is the strobe for the A15 RF Assembly.
3. Press **AUX CTRL** and **REAR PANEL** and check that pulses occur when toggling between **10 MHz INT** and **10 MHz EXT**.
4. Monitor U401 pin 5 (LFC_STB) with an oscilloscope or logic probe. This is the strobe for the A14 frequency control assembly.
5. Press **AMPLITUDE** and check that pulses occur when toggling between **ATTEN** settings of 10 and 20 dB.
6. Monitor U401 pin 7 (LIF_STB) with an oscilloscope or logic probe. This is the strobe for the A5 IF assembly.
7. Press **AMPLITUDE** and check that pulses occur when toggling between **REF LVL** settings of -10 dBm and -20 dBm.
8. Monitor U401 pin 9 (LLOG_STB) with an oscilloscope or logic probe. This is the strobe for the log amplifier on the A4 assembly.
9. Press **AMPLITUDE** and check that pulses occur when toggling between **LINEAR** and **LOG dB/DIV**.
10. To check the Address and Data Lines, place a jumper from A3TP1 and A3TP2 to A3U406 pin 20 (+5 V).
11. Check that address lines A0 through A7 and data lines D0 through D7 are all TTL high.

12. If any address or data line is low, press **LINE** to turn spectrum analyzer off and disconnect the W2 control cable from A3J2. Press **LINE** to turn spectrum analyzer on. Ignore any error messages.
13. Check that address lines A0 through A7 and data lines D0 through D7 are all high. If all address and data lines are high, suspect a fault either in W2 or one of the other four assemblies which connect to W2.
14. If any address or data line is low, check the appropriate input of either U405 (data lines) or U406 (address lines).
15. If a data line input is stuck low, check the data bus buffer. If an address line input is stuck low, check A3W1 and the A2 controller assembly.
16. If the appropriate input is high or toggling between high and low, suspect a failure in either U405 (data lines) or U406 (address lines).
17. Remove jumpers.

Analog Bus Timing

Refer to function block P of A3 Interface Assembly Schematic Diagram (sheet 4 of 6) in the *HP 8560 E-Series Spectrum Analyzer Component Level Information*.

Analog bus timing (ABT) generates the strobes for the A4, A5, A14, and A15 assemblies. The A14 frequency control assembly also requires a qualifier for its strobe, LVFC_ENABLE. A3U400 and A3U414 provide a 2 μ s delay between the time HANA_BUS goes high and the enable line to demultiplexer A3U407 goes low.

1. Press **PRESET** on the HP 8560E/EC and set the controls as follows:

| | |
|------------------------|---------|
| Center frequency | 300 MHz |
| Span | 100 MHz |
2. Check that A3U407 pin 1 goes low approximately 2 μ s after HANA_BUS (A3U400 pin 3) goes high.
3. If HANA_BUS is absent, check for pulses on ABT A3U505 pin 2 and IA10 (A3U505 pin 5).
4. If A3U407 pin 1 is not delayed 2 μ s from HANA_BUS, check for the presence of the 1 MHz HBADC_CLK0.
5. If A3U407 pin 1 is not delayed 2 μ s from HANA_BUS and HBADC_CLK0 is correct, suspect a fault in either A3U414 or A3U400.
6. Press **PRESET** and set the controls as follows:

| | |
|---------------|--------|
| Span | 0 Hz |
| Trigger | SINGLE |

7. Monitor A3U401 pin 3 (LR_STB) with an oscilloscope or logic probe. This is the strobe for the A15 RF assembly.
8. Press **AUX CTRL** and **REAR PANEL** and check that pulses occur when toggling between **10 MHz INT** and **10 MHz EXT**.
9. Monitor A3U401 pin 5 (LF_STB) with an oscilloscope or logic probe. This is the strobe for the A14 frequency control assembly.
10. Press **AMPLITUDE** and check that pulses occur when toggling between **ATTEN** settings of 10 and 20 dB.
11. Monitor A3U401 pin 7 (LI_STB) with an oscilloscope or logic probe. This is the strobe for the A5 IF assembly.
12. Press **AMPLITUDE** and check that pulses occur when toggling between **REF LVL** settings of -10 dBm and -20 dBm.
13. Monitor A3U401 pin 9 (LV_STB) with an oscilloscope or logic probe. This is the strobe for the A4 log amplifier/cal oscillator assembly.
14. Press **AMPLITUDE** and check that pulses occur when toggling between **LINEAR** and **LOG DB/DIV**.

Interface Strobe Select

Refer to function block K of A3 Interface Assembly Schematic Diagram (sheet 3 of 6) in the *HP 8560 E-Series Spectrum Analyzer Component Level Information*.

Interface strobe select generates the various strobes used by circuits on the A3 Interface Assembly. [Table 7-10 on page 387](#) and [Table 7-11 on page 388](#) are the truth tables for demultiplexers A3U410 and A3U500.

Table 7-10 Demultiplexer A3U410 Truth Table

| Selected Output Line | IA1 | IA2 | IA3 |
|----------------------|-----|-----|-----|
| Pin 15, LSCAN_KBD | L | L | L |
| Pin 14, LDACU1 | H | L | L |
| Pin 13, LDAC1 | L | H | L |
| Pin 12, LDAC2 | H | H | L |
| Pin 11, LDAC3 | L | L | H |
| Pin 10 | H | L | H |
| Pin 9, LTIMER | L | H | H |
| Pin 7, LADC_REG1 | H | H | H |

Table 7-11 Demultiplexer A3U500 Truth Table

| Selected Output Line | IA0 | IA1 | IA2 |
|-----------------------------|------------|------------|------------|
| Pin 15, LSENSE_KBD | L | L | L |
| Pin 14, LINT_PRIOR | H | L | L |
| Pin 13, LADC_DATA1 | L | H | L |
| Pin 12, LDAC_DATA0 | H | H | L |
| Pin 11, HCNTR_LD0 | L | L | H |
| Pin 10, HCNTR_LD1 | H | L | H |
| Pin 9, LRPG_RD | L | H | H |
| Pin 7, LADC_REG0 | H | H | H |

A16 Assembly Fast ADC Circuits (8560E with Option 007)

The fast ADC consists of video signal scaling and limiting amplifiers, an 8-bit flash ADC, peak/pit detection of the digitized video signal, a 32 K-byte RAM, and the fast ADC control circuitry.

Video Input Scaling Amplifiers and Limiter

Refer to function block L of the A16 fast ADC assembly schematic diagram in the *HP 8560 E-Series Spectrum Analyzer Component Level Information*.

The video input scaling amplifiers help provide scaling (10 dB/div, 5 dB/div, 2 dB/div, or 1 dB/div) and buffer the flash video output. When the GAINX2 control line is low, switch U44D is open and switch

U44C is closed. Thus, the scaled video at TP26 virtually follows the video input (0 - 1 V). When the GAINX2 control line is high, switch U44C is open and switch U44D is closed. Amplifier U43 then provides a gain of $2(V_{in}) - 1$ V. Voltage clamp CR4 prevents the scaled video input to amplifier U45 from going more negative than -0.35 V or more positive than $+1.25$ V.

NOTE

When measuring voltages or waveforms on the A16 fast ADC assembly, connect the ground (or common) lead to the ground-plane trace on the A16 assembly. This digital ground plane is totally isolated from the chassis.

1. Press **PRESET** on the HP 8560E Option 007 and set the controls as follows:

| | |
|------------------------|-----------|
| Center frequency | 300 MHz |
| Span | 0 Hz |
| Reference level | -10 dBm |
| Log/division | 10 dB/div |
| Sweep time | 20 ms |
2. Connect the CAL OUTPUT to the INPUT 50 Ω connector.
3. Adjust the HP 8560E Option 007 reference level to place the signal at the top graticule line on the CRT display.
4. Measure the dc level at TP25. If the voltage measured is not $+1.0 \pm 0.15$ V, troubleshoot the A3 interface assembly.
5. Measure the dc level at TP26. The level should be approximately the same as the level measured at TP25. If not, suspect switch U44.
6. Set the HP 8560E Option 007 scale to 5dB per division.

7. Adjust the HP 8560E Option 007 reference level to place the signal at the top graticule line on the CRT display.
8. Measure the dc level at TP25 and TP26. The level should be $+1.0 \pm 0.25$ V. If the level measured at TP26 differs from the level measured at TP25 by more than 0.25 volts, troubleshoot U43 and associated circuitry.
9. Disconnect the CAL OUTPUT signal from the INPUT 50 Ω connector.
10. The level at TP26 should drop to -0.35 Vdc. If the level is less (more negative) than -0.35 Vdc, replace voltage clamp CR4.
11. Measure the dc level of the flash video at TP27. The level should be near 0 Vdc with the signal at the bottom graticule line (no input to the spectrum analyzer).
12. Connect the CAL OUTPUT to the INPUT 50 Ω connector.
13. Measure the dc level of the flash video at TP27. The level should be near $+1.7$ Vdc.

8-Bit Flash ADC

Refer to function block I of the A16 fast ADC assembly schematic diagram in the *HP 8560 E-Series Spectrum Analyzer Component Level Information*.

The flash ADC (U35) converts the analog video signal into 8-bit digital values at a fixed rate of 12 megasamples per second.

NOTE

When measuring voltages or waveforms on the A16 fast ADC assembly, connect the ground (or common) lead to the ground-plane trace on the A16 assembly. This digital ground plane is totally isolated from the chassis.

1. Press **PRESET** on the HP 8560E Option 007 and set the controls as follows:

| | |
|------------------------|----------|
| Center frequency | 300 MHz |
| Span | 0 Hz |
| Reference level | -20 dBm |
| Log/division | 5 dB/div |
| Sweep time | 20 ms |
2. Connect the CAL OUTPUT to the INPUT 50 Ω connector.
3. Pins 4 through 10 (ADC7-ADC1) and pin 21 (ADC0) of U35 should all be high (logic 1), corresponding to an ADC digital count of 255 for the analog input of $+2$ volts or greater.
4. Disconnect the CAL OUTPUT signal from the INPUT 50 Ω connector.

5. Pins 4 through 10 (ADC7-ADC1) and pin 21 (ADC0) of U35 should all be low (logic 0), corresponding to an ADC digital count of zero for the analog input of 0 volts or less.

Peak/Pit Detection

Refer to function block J of the A16 fast ADC assembly schematic diagram in the *HP 8560 E-Series Component Level Information*.

Peak detection or pit (negative peak) detection can be enabled whenever the sample rate is less than 12 MHz (sweep times greater than 50 μ s). Peak detection uses the maximum value of all the samples taken within each bucket (between adjacent display points). Pit detection uses the minimum value of all the samples taken within each bucket. And sample detection uses the last sample of all the samples taken within each bucket.

The different detection modes are implemented by selectively clocking latch U30, depending on the state of LP/Q which is generated in PAL U1 (block A). When LP/Q is low, U30 is clocked by WCLK. When LP/Q is high, U30 is not clocked. LP/Q is a function of the 12M_SEL, SCLK-1, LSAMPLE, LPEAK, P_LO, and P_HI signals. See [Table 7-12 on page 392](#).

If the sample rate is 12 MHz, 12M_SEL is high, which forces LP/Q low so that every sample is clocked into latch U30 and latched into RAM U32 (block K). If the sample rate is less than 12 MHz and the detection mode is peak or pit, the SCLK-1, LPEAK, P_LO, and P_HI signals control the LP/Q signal. In these detection modes, latch U30 stores the peak or pit value of the samples taken for each bucket. The 8-bit digital magnitude comparator, U31, compares the input byte (P) with the output byte (Q) from latch U30. When P is greater than Q, P_LO is low (0) and P_HI is high (1). When P is less than Q, P_LO is high (1) and P_HI is low (0). When P is equal to Q, P_LO and P_HI are both low (0). See [Table 7-12 on page 392](#).

Table 7-12

LP/Q Truth Table

| Mode | LP/Q | 12M_SEL | SCLK-1 | LSAMPLE | LPEAK | P_LO | P_HI |
|----------|------|---------|--------|---------|-------|------|------|
| 12MHz | L | H | X | X | X | X | X |
| SAMPLE | L | X | X | L | X | X | X |
| POS | L | L | L | H | L | L | H |
| PEAK | H | L | L | H | L | H | L |
| | H | L | L | H | L | L | L |
| NEG | H | L | L | H | H | L | H |
| PEAK | L | L | L | X | H | H | L |
| (Pit) | H | L | L | H | H | L | L |
| Clocking | L | L | H | H | X | X | X |
| Peak/Pit | | | | | | | |
| Sample | | | | | | | |

32 K-Byte Static RAM

Refer to function block K of the A16 fast ADC assembly schematic diagram in the *HP 8560 E-Series Component Level Information*.

The static RAM stores the flash ADC samples that are taken when the fast ADC circuitry is in the "write" mode. When not in the "write" mode, the static RAM is read by the CPU on the A2 controller assembly to retrieve the fast ADC data.

The 8-bit Q bus connects the outputs of latch U30 to the data port of static RAM U32.

A16 Assembly Fast ADC Control Circuits (8560E with Option 007)

The fast ADC control circuits consist of the CPU interface and control registers, the reference clock, a clock and sample rate generator, a trigger circuit, a 16-bit post-trigger counter, a 15-bit circular address counter, a video trigger comparator, and the reference and power supply circuits.

CPU Interface and Control Registers

Refer to function block A of the A16 fast ADC assembly schematic diagram in the *HP 8560 E-Series Component Level Information*.

The A16 assembly digital interface to the A2 controller assembly consists of an 8-bit bi-directional data bus, one address line, a most-significant byte strobe, and a least-significant byte strobe.

The A16 fast ADC assembly can be accessed by firmware (on the A2 controller assembly) at two logical addresses. When the address line (ADDR3) is low, the primary address is selected. When the ADDR3 is high, the secondary address is selected. The data transfers between the A16 fast ADC assembly and the A2 controller assembly are clocked by the two strobe lines, MSB_STRB and LSB_STRB. 16-bit word transfers occur as two sequential byte transfers; the most-significant byte first, followed by the least-significant byte.

The primary address (ADDR3 low) contains the 16-bit control word written by the firmware on the A2 controller assembly. The secondary address (ADDR3 high) supports both 8-bit byte and 16-bit word reads and writes. There is no read/write line on the A16 fast ADC assembly to control the direction of data transfer. The fast ADC is preconfigured to read or write by setting the appropriate bits in the 16-bit control word. Refer to [Table 7-13 on page 394](#). If the control word is not correct, it may result in a bus conflict.

Table 7-13 Control Word at Primary Address (U3 and U4)

| Bit | Mnemonic | State | Description |
|-------|-----------|-------|---|
| Bit 0 | WRITE | 1 | Allows samples to be written to FADC memory. All on-board clocks running and samples being written to FADC memory. (FADC memory cannot be read by A2 controller in this mode.) |
| | | 0 | All on-board clocks turned off and no samples being written to FADC memory. (FADC memory can be read by A2 controller.) |
| Bit 1 | ARM | 1 | Arms the FADC assembly for a trigger. FADC assembly armed to accept trigger from HSWP line or video trigger. |
| | | 0 | FADC assembly cannot be triggered. |
| Bit 2 | GAINX2 | 1 | Turns on X2 log expand amplifier. A16U43 turned on. (5 dB/div or 1 dB/div scale) |
| | | 0 | A16U43 turned off. (10 dB/div, 2 dB/div, or linear scale) |
| Bit 3 | VTRIG_POL | 1 | Controls digital video trigger polarity. Negative-edge video trigger |
| | | 0 | Positive-edge video trigger |
| Bit 4 | LSAMPLE | 1 | Enables sample detection mode. Sample detection mode disabled. Sample detection mode enabled |

Table 7-13 Control Word at Primary Address (U3 and U4)

| Bit | Mnemonic | State | Description |
|-------|-----------|-------|---|
| Bit 5 | LADCEN | | Enables FADC memory for "writes". (Toggled in conjunction with bit 0.) |
| | | 1 | Disables FADC memory for "writes". |
| | | 0 | Enables FADC memory for "writes". |
| Bit 6 | LLOADADDR | | Enables load address counter. |
| | | 1 | "Writes" to the address counter disabled. |
| | | 0 | "Writes" to the address counter enabled. |
| Bit 7 | LLOADPOST | | Enables load post-trigger counter. |
| | | 1 | "Writes" to the post-trigger counter disabled. |
| | | 0 | "Writes" to the post-trigger counter enabled. |
| Bit 8 | LVTRIG_EN | | Enables digital video trigger on A16. |
| | | 1 | Digital video trigger disabled. |
| | | 0 | Digital video trigger enabled. |
| Bit 9 | LREADCLK | | Clocks counters during "read" mode. Used to load post-trigger counter or address counter. Also used to post-increment address counter following memory "reads". |
| | | 1 | Read clock disabled. |
| | | 0 | Read clock enabled. |

Table 7-13 Control Word at Primary Address (U3 and U4)

| Bit | Mnemonic | State | Description |
|--------|------------|-------|---|
| Bit 10 | LREADMEM | | Enables read FADC memory. |
| | | 1 | Read FADC memory disabled. |
| | | 0 | Read FADC memory enabled. |
| Bit 11 | LREADADDR | | Enables read trigger address latch. |
| | | 1 | "Reads" from trigger address latch disabled. |
| | | 0 | "Reads" from trigger address latch enabled. |
| Bit 12 | LRATELATCH | | Enables load sample rate latch. |
| | | 1 | "Writes" to the sample rate latch are disabled. |
| | | 0 | "Writes" to the sample rate latch are enabled. |
| Bit 13 | LRLSHSWP | | Releases HSWP strobe. |
| | | 1 | Release HSWP strobe disabled. |
| | | 0 | Release HSWP strobe enabled. |
| Bit 14 | LLOADTRIG | | Enables load video trigger level. |
| | | 1 | Load digital video trigger level disabled. |
| | | 0 | Load digital video trigger level enabled. |

Table 7-13 Control Word at Primary Address (U3 and U4)

| Bit | Mnemonic | State | Description |
|--------|----------|-------|---|
| Bit 15 | LPEAK | | Peak/pit detection mode control. |
| | | 1 | Enables pit (negative-peak) detection mode if LSAMPLE (Bit 4) is also high. |
| | | 0 | Enables peak detection mode if LSAMPLE (Bit 4) is high. |

Reference Clock

Refer to function block B of the A16 fast ADC assembly schematic diagram in the *HP 8560 E-Series Component Level Information*.

The reference clock circuitry takes the 8 MHz CMOS square wave clock from the A2 controller assembly (via W59, coax 839) and triples the frequency to 24 MHz. Inverters U5A and U5B provide the proper match for the 8 MHz clock input, and also the desired drive level into the 24 MHz bandpass filter. The 24 MHz bandpass filter consists of R5, C8, L1, C9, C10, L2, C11, L3, C12, L4, C13, C14, and R6. Inverters U6A and U6B provide amplification of the 24 MHz clock to produce CMOS levels, and also buffer the 24 MHz clock output.

Clock and Sample Rate Generator

Refer to function block C of the A16 fast ADC assembly schematic diagram in the *HP 8560 E-Series Component Level Information*.

The clock and sample rate generator takes the 24 MHz reference clock signal and generates all of the various clock signals used on the A16 fast ADC assembly. The sample rate generator consists of CMOS latch U15, CMOS counters U14 and U16, and CMOS flip-flops U7B and U9A. The sample rate generator only controls the rate at which the static RAM address counter (15-bit circular address counter) and the 16-bit post-trigger counter are clocked (ACLK and PCLK respectively). The sample rate generator also controls the number of flash ADC samples taken per bucket. The range of the sample rate is 1 sample per bucket (12 MHz rate) to 256 samples per bucket (less than 12 MHz rate). SCLK-1 is an input to PAL U1 (block A) and affects the LP/Q signal to ensure that the first sample of a bucket is always clocked into latch U30 (block J) and written into static RAM U32 (block K) when the detection mode is peak or pit and the sample rate is less than 12 MHz. Refer to Table 7-12, LP/Q Truth Table in this chapter.

Trigger

Refer to function block D of the A16 fast ADC assembly schematic diagram in the *HP 8560 E-Series Component Level Information*.

When the A16 fast ADC is triggered, the current static RAM address is latched into trigger address latches U27 and U28 (block G), and the post-trigger counter (U19, U20, U21, U22, and U47) begins counting.

Samples continue to be written to consecutive addresses in RAM U32 until the post-trigger counter reaches its terminal count. The CPU on the A2 controller assembly monitors the HSWP line and starts a software timer when HSWP goes high after being triggered. The software timer is set to slightly longer than the post-trigger counter will be counting, so at the end of the "time-out", the post-trigger counter has already reached its terminal count. At the end of this "time-out", the CPU on the A2 controller assembly takes the fast ADC out of "write" mode and reads latches U27 and U28 to determine the static RAM address of the sample that was taken when the trigger occurred. The CPU then writes the trigger address (read at U27/U28) to the fast ADC static RAM address counter (15-bit circular address counter). If pre-trigger or post-trigger (delay) is being used, the CPU adds or subtracts appropriately and writes the "adjusted" trigger address to the static RAM counter. The CPU then begins reading the fast ADC data, starting from the trigger (or offset trigger) address.

The trigger circuitry is enabled by the ARM signal (bit 1 of the fast ADC control word). Once a trigger occurs, the fast ADC cannot be triggered again until the ARM line goes low (disarmed), then high again (armed).

The fast ADC is triggered by the HSWP line in **FREE RUN**, **LINE**, and **EXTERNAL** trigger modes. When **VIDEO** trigger is being used, a synchronous digital video trigger signal, VCLK, is generated by PAL U1 (block A) and U17A (block D).

316-Bit Post-Trigger Counter

Refer to function block E of the A16 fast ADC assembly schematic diagram in the *HP 8560 E-Series Component Level Information*.

The 16-bit post-trigger counter controls the number of static RAM memory locations that will be written after the trigger occurs. This counter consists of U19, U20, U21, U22, and U47. The counter is loaded from the CPU on the A2 controller assembly when the A16 fast ADC assembly is in "read" mode. The CPU loads the counter by first setting the LLOADPOST (bit 7 of the fast ADC control word) and the LREADCLK (bit 9 of the fast ADC control word) to their low state. The CPU then writes the 16-bit word to the fast ADC secondary address. The rising edge of PCLK then latches the 16-bit data into the post-trigger counter.

The post-trigger counter begins counting upward in "write" mode on the first rising edge of PCLK after the LCOUNT signal from the trigger circuit goes low. The frequency of PCLK is the programmed sample rate. When the post-trigger counter reaches its terminal count, the LSTOP signal goes low and disables the static RAM address counter from further counting. LSTOP also forces LCOUNT high in NAND gate U11D, which disables the post-trigger counter.

15-Bit (32 K) Circular Address Counter

Refer to function block G of the A16 fast ADC assembly schematic diagram in the *HP 8560 E-Series Component Level Information*.

This 15-bit programmable circular counter provides the address lines of the static RAM (U32). The counter consists of U23, U24, U25, and U26. It counts upward from 0 to 32767 and then back to 0 in a circular fashion. When a trigger occurs, latches U27 and U28 latch the current static RAM address so that the CPU on the A2 controller assembly can later read the latches and determine the static RAM address of the sample that was taken when the trigger occurred.

The CPU loads the address counter during "read" mode by first setting LLOADADDR (bit 6 of the fast ADC control word) and LREADCLK (bit 9 of the fast ADC control word) to their low state. The CPU then writes the 16-bit load value to the CPU secondary address. The rising edge of ACLK then latches the 16-bit data into the address counter.

After the address counter is loaded by the CPU during "read" mode, the static RAM is read by the CPU. The RAM is read by first setting LREADMEM (bit 10 of the fast ADC control word) and LREADCLK (bit 9 of the fast ADC control word) to their low state. Since the LREADCLK control bit is low, a negative-going pulse on the ACLK line will occur on every static RAM "read" by the CPU. This causes the address counter to increment at the end of each static RAM "read" so that the address counter automatically post-increments to the next address of RAM U32. In order for this address post-increment to occur, the LSTOP count enable signal from the post-trigger counter must be high. LSTOP goes low when the post-trigger counter reaches its terminal count in the "write" mode to stop the address counter from counting. When the fast ADC assembly is changed from "write" mode to "read" mode, LSTOP will be low. So the CPU on the A2 controller board must always first program the post-trigger counter to a value other than the terminal count (65535) to force LSTOP high.

Video Trigger Comparator

Refer to function block M of the A16 fast ADC assembly schematic diagram in the *HP 8560 EC-Series Component Level Information*.

This 8-bit digital magnitude comparator, U34, compares the digitized samples from the flash ADC (latch U29 output) to the programmed

video trigger level. The video trigger level value on IOB2 through IOB7 is latched into the P input (top portion of U34) by the firmware on the A2 controller assembly when the fast ADC is in "read" mode. When the sample on the Q input is higher than the video trigger level on the P input, V_HI output is high, and V_LO output is low. When the Q input is lower than the P input, V_HI output is low and V_LO output is high. And when P is equal to Q, both V_HI and V_LO are low. These two signals (V_HI and V_LO) go to PAL U1 (block A) and are used to clock the video trigger generator (block D).

Figure 7-2 **A3 Interface Assembly Block Diagram**

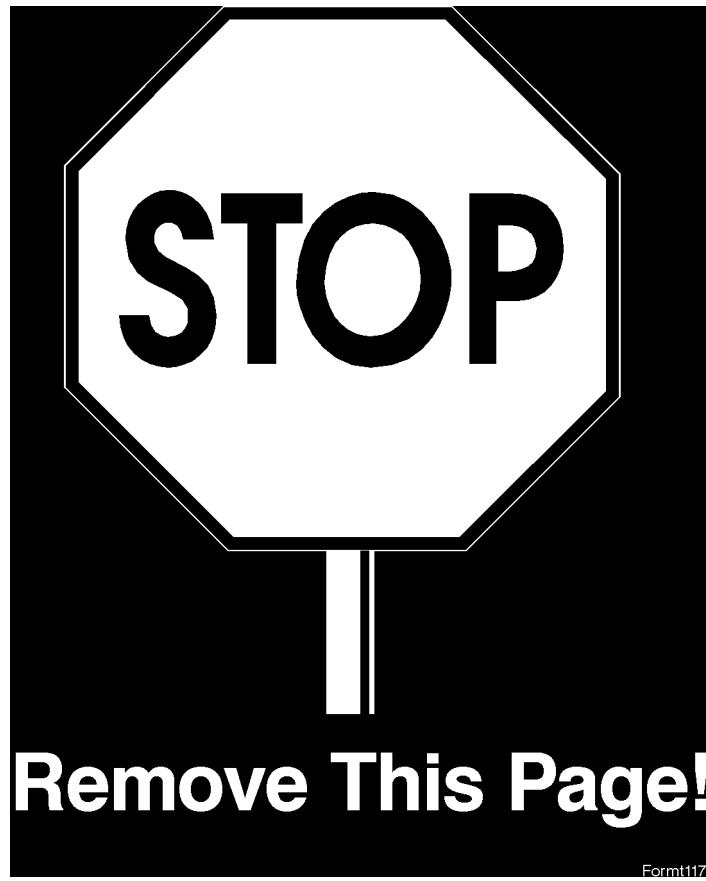

Replace with sj18c

Figure 7-3 Fast ADC Block Diagram (Option 007 in E-series instruments)

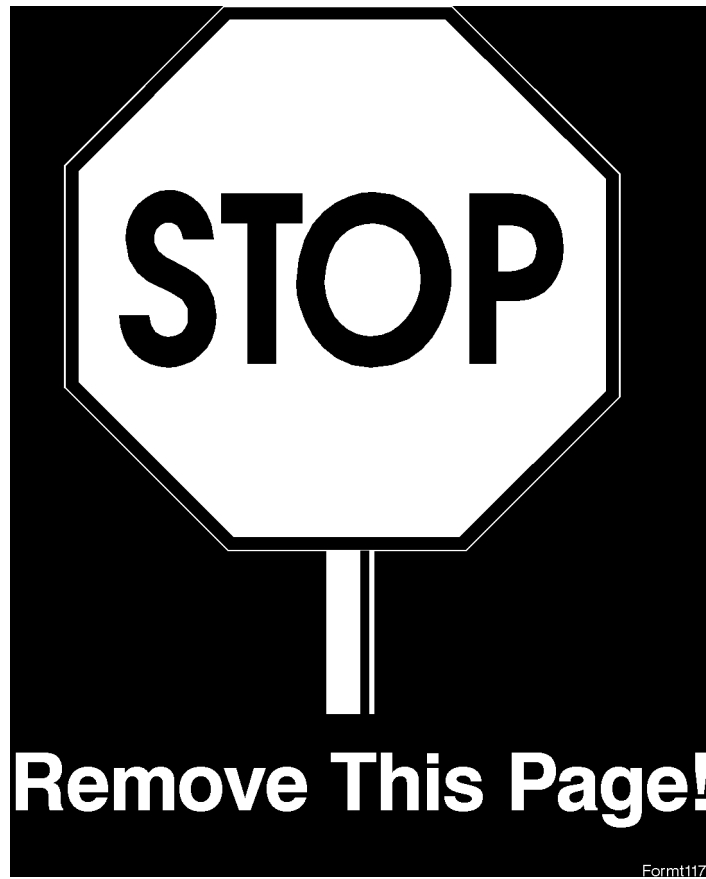

Replace with sj139e

8 **IF Section**

Introduction

The IF Section contains the A4 Log Amplifier/Cal Oscillator and A5 IF assemblies.

| | |
|--|----------|
| Troubleshooting Using the TAM..... | page 408 |
| Troubleshooting the Log Amplifier with the TAM..... | page 409 |
| Troubleshooting A5 with the TAM..... | page 409 |
| Troubleshooting the Cal Oscillator with the TAM..... | page 413 |
| Automatic IF Adjustment..... | page 415 |
| Parameters Adjusted | page 416 |
| Requirements | page 417 |
| Performance Test Failures..... | page 419 |
| IF Gain Uncertainty Performance Test | page 419 |
| Scale Fidelity Performance Test..... | page 420 |
| Resolution Bandwidths Performance Tests | page 420 |
| Log Amplifier Assembly (P/O A4)..... | page 421 |
| Log Amplifier..... | page 421 |
| Linear Amplifiers | page 422 |
| Video Offset | page 423 |
| Video Output | page 424 |
| Frequency Counter Prescaler/Conditioner | page 425 |
| AM/FM Demodulator | page 425 |
| 4.8 kHz IF Filters..... | page 426 |
| 10.7 MHz IF Filters..... | page 426 |
| 4.8 kHz and 10.7 MHz IF Filters | page 427 |
| 10.6952 MHz VCXO | page 428 |
| Input Switch..... | page 428 |
| LO Switch | page 428 |
| Synchronous Detector | page 429 |
| Limiter | page 429 |
| Isolation Amplifier | page 430 |
| Detector/Mixer..... | page 430 |
| Log Offset/Gain Compensation | page 430 |
| Log Offset Compensation..... | page 430 |
| Log Gain Compensation..... | page 430 |
| Video MUX | page 431 |
| A5 IF Assembly | page 432 |
| IF Signature | page 433 |
| Common IF Signature Problems..... | page 441 |
| 1 MHz Resolution Bandwidth Problems..... | page 445 |
| 30 kHz Resolution Bandwidth Problems..... | page 447 |
| 3 kHz and 10 kHz Resolution Bandwidth Problems..... | page 448 |
| Step Gains | page 449 |
| Cal Oscillator Assembly (P/O A4) | page 450 |
| Cal Oscillator Unlock at Beginning of IF Adjust..... | page 451 |
| Inadequate CAL OSC AMPTD Range | page 452 |
| 300 Hz to 3 kHz Resolution Bandwidth Out of Specification... | page 453 |

Low-Pass Filter page 459
Sweep Generator page 460
AM/FM Demodulation, Audio Amplifier, and Speaker ... page 460

NOTE

Because the cal oscillator circuitry on the A4 assembly is such an integral part of the IF adjustment, always check this assembly first, before checking the rest of the IF Section. A faulty cal oscillator can cause many apparent "faults" in the rest of the IF Section.

Troubleshooting Using the TAM

When using Automatic Fault Isolation, the TAM indicates suspected circuits that need to be manually checked. Use [Table 8-1 on page 408](#) to locate the manual procedure. [Table 8-2 on page 410](#) lists assembly test connectors associated with each Manual Probe Troubleshooting test. [Figure 8-1 on page 408](#) illustrates the location of A4 and A5 test connectors. [Figure 8-2 on page 412](#) illustrates the levels and paths through the IF Section.

Figure 8-1 A4 and A5 Test Connectors

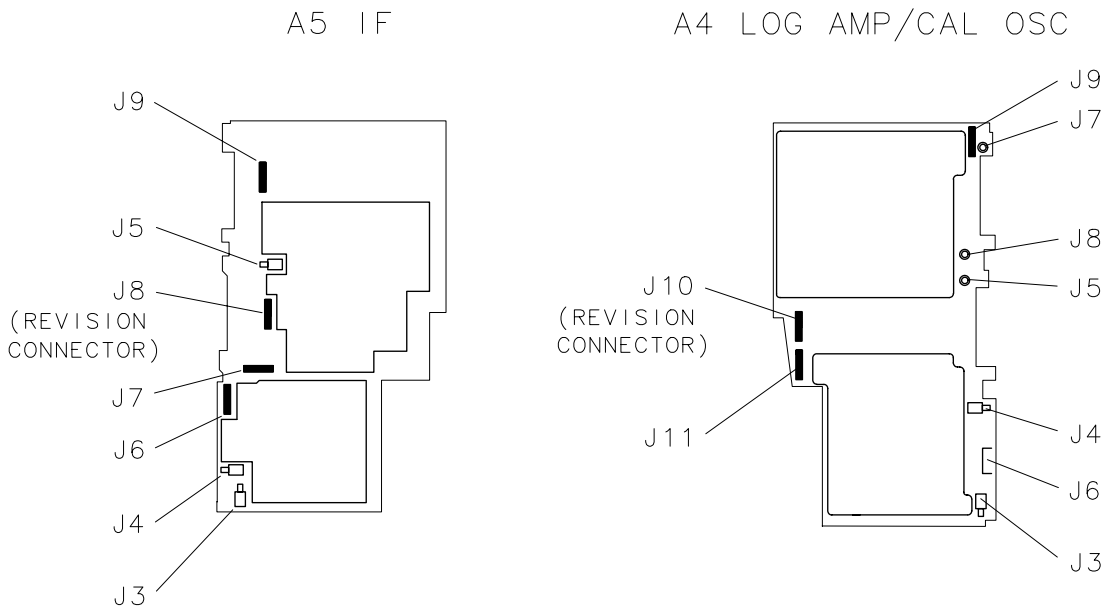

sp168e

Table 8-1 Automatic Fault Isolation References

| Suspected Circuit Indicated by Automatic Fault Isolation | Manual Procedure to Perform |
|--|---|
| Check Cal Oscillator on A4 Assembly | Troubleshooting the Cal Osc with the TAM |
| Check Input Switch on A5 IF Assembly | Troubleshooting A5 with the TAM |
| Check Linear Amplifiers on A4 Assembly | Linear Amplifiers |
| Check Log Expand on A3 Interface Assembly | Refer to "Log Expand" in this chapter |
| Check Step Gains on A5 IF Assembly | Step Gains |
| Check Video Offsets on A4 Assembly | Video Offset (<i>steps 1 through 4</i>) |
| Check VIDEO OUT on A4 Assembly | Video Output |

Troubleshooting the Log Amplifier with the TAM

Manual probe troubleshooting tests several dc bias points and signal path voltages. A dc bias is measured in the limiter and a fault here indicates a broken limiter stage. Signal path voltages are measured at the input, after the video amplifier in the linear path, after the offset and gain compensation circuits in the log path, and after the video offset.

The cal oscillator on A4 is used as an input to the log amp for the purpose of measuring gains. Faults in the signal path voltages indicate broken circuitry in prior stages. This technique locates dead stages, but might not report slightly degraded ones. Both +15 V and -15 V are measured. The revision code is on J11.

Troubleshooting A5 with the TAM

Manual Probe Troubleshooting calculates stage bias-currents which test the operation of the IF chain. (This technique locates dead stages, but might not report slightly degraded ones.) DACs that are monitored are listed below:

| | |
|--------------|--------|
| IFDAC1 | A5U812 |
| IFDAC2 | A5U813 |
| IFDAC3 | A5U809 |
| IFDAC4 | A5U807 |
| IFDAC5 | A5U810 |
| IFDAC6 | A5U806 |

Table 8-2 TAM Tests versus Test Connectors

| Connector | Manual Probe Troubleshooting Test | Measured Signal Lines |
|------------------|--|--|
| A3J105 | Video Input to Interface Video to Rear Panel Video MUX Log Offset/Log Expand Video Filter Buffer Amplifier Video Peak Detectors ADC MUX Variable Gain Amplifier Track and Hold | MS1 MS2 MS3 MS1,MS3 MS3, MS5, OS1 MS5, MS6 MS6 MS6, MS7 MS7, MS8 |
| A3J400 | Video Trigger DAC Revision Real Time DAC #1 RF Gain DACs ADC Start/Stop Control Trigger | MS1 MS2 MS3 MS6 MS7 MS8 |
| A4J9 | Cal Osc Sweep Gen Hardware Cal Osc Tune Line Test Cal Osc ALC Test Cal Osc Sweep Gen Output | MS1, MS2 MS3 MS4 MS6 |
| A4J10 | Log Amp Input Switch Log Amp Limiter Bias Positive 15 V Supply | MS1 MS2 MS5 |
| A4J11 | Logamp Linear Output Logamp Linear MUX Path Logamp Log Output Logamp Compensation Logamp Log MUX Path Logamp Video Offset -15 Volt Supply Revision | MS2 MS2,MS3,MS8 MS3 MS3,MS4 MS4,MS8 MS8 MS7 MS5 |
| A5J6 | 1st Step Gain Stage 1 1st Step Gain Stage 2 1st XTAL Pole Stage 2nd XTAL Pole Stage 1st LC Pole Stage 1 1st LC Pole Stage 2 | MS1, MS2, MS8 MS1, MS2, MS3 MS2, MS3, MS4 MS3, MS4, MS5 MS4, MS5, MS6 MS5, MS6, MS7 |
| A5J7 | Ref 15 dB Attenuator Stage 2nd Step Gain Stage 2nd/3rd Step Gain Stage 3rd Step Gain Stage Fine Atten/3rd XTL Pole 3rd XTAL Pole Stage | MS1, MS2, MS3 MS2, MS3, MS4 MS3, MS4, MS5 MS4, MS5, MS6 MS5, MS6, MS7 MS6, MS7, MS8 |

Table 8-2 TAM Tests versus Test Connectors

| Connector | Manual Probe Troubleshooting Test | Measured Signal Lines |
|-----------|--|---|
| A5J8 | Revision 4th XTAL Pole Stage Post Amplifier Stage 1 Post Amplifier Stage 3 3rd LC Pole Stage 4th LC Pole Stage | MS8 MS1, MS2, MS3 MS2, MS3, MS4 MS3, MS4, MS5 MS5, MS6, MS7 MS6, MS7 |
| A5J9 | IFDAC Channels `A` IFDAC Channels `B` IFDAC Channels `C` IFDAC Channels `D` Latched IF Control Lines Negative 15 V Supply 5 Volt Supply 10 Volt Reference | MS1 MS3 MS4 MS2 MS5 MS6 MS7 MS8 |

Figure 8-2 IF Section Troubleshooting with the TAM

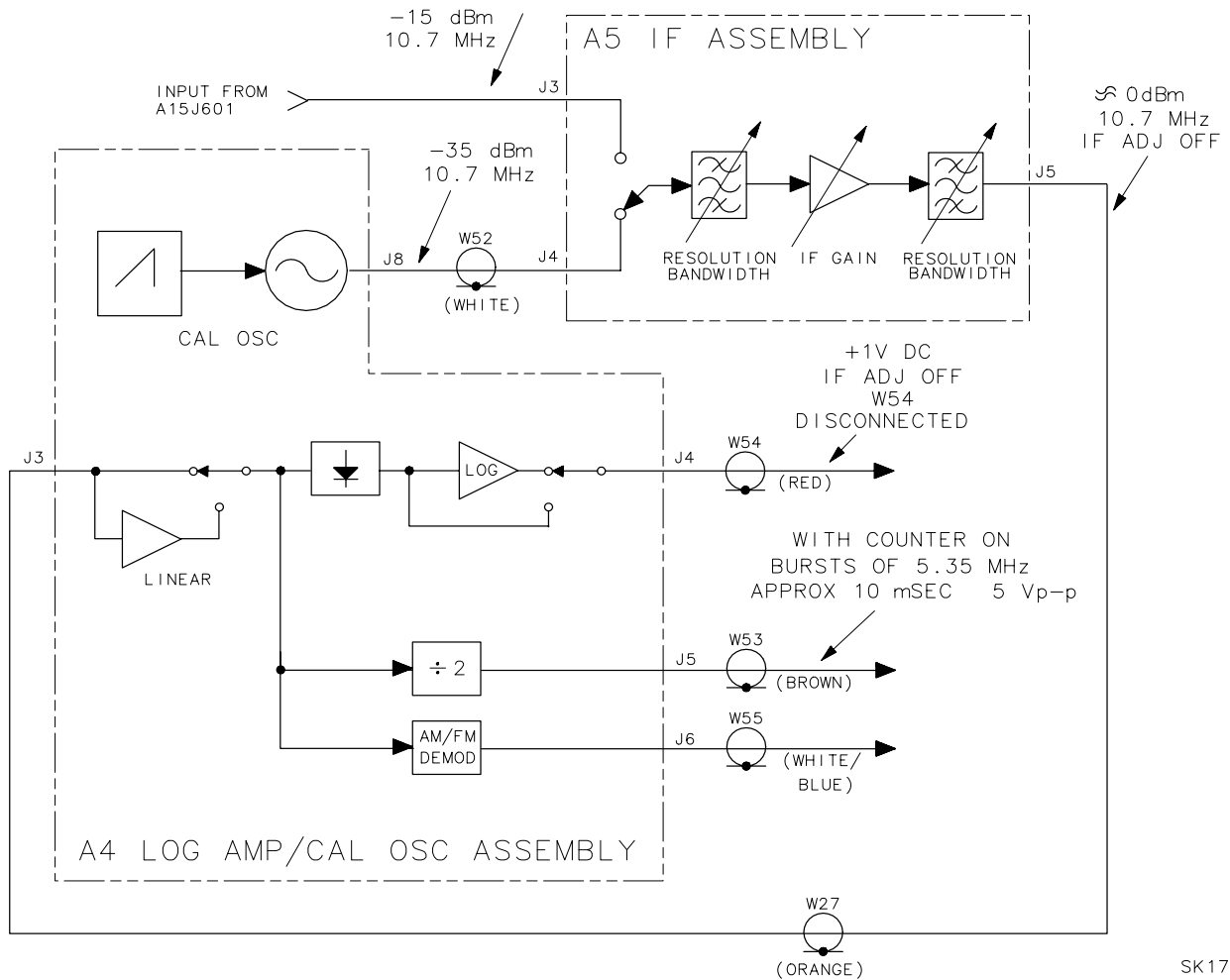

SK171

Both the digital control and DACs are multiplexed onto test point "channels" through resistive networks. One DAC from each of the quad-DAC packages feeds into a network. The TAM varies each DAC individually to isolate which ones failed. Similarly, 10 digitally-controlled lines feed into a network and are monitored by the TAM. The channels used to monitor the DACs are listed below:

1. On the HP 8560E/EC, press **PRESET, MODULE,** and **Diagnose.** Select **Cal Osc Troubleshooting Mode.**
2. On the HP 8560E/EC, disconnect W27 (coax 3) from A5J5 and monitor the output of A5J5 with a second spectrum analyzer.

3. Set the other spectrum analyzer controls as follows:
 - Span 5 MHz
 - Reference level -20 dBm
 - Center frequency 10.7 MHz
4. On the HP 8560E/EC, set the cal oscillator to 10.7 MHz by selecting **Fixed Tuned to 10.7 MHz**.
5. A -25 dBm signal from A5J5 should be displayed. If the signal is missing, disconnect W52 (coax 9) from A5J4. This is the cal oscillator signal input from the cal oscillator on the A4 assembly.
6. Connect the end of cable W52 to the input of the second spectrum analyzer. The signal coming from cable W52 should be -35 dBm at 10.7 MHz. If the cal oscillator signal from cable W52 is correct, the A5 IF assembly is probably at fault.

Troubleshooting the Cal Oscillator with the TAM

1. Enter the TAM Cal Osc Troubleshooting Mode.
2. On the spectrum analyzer, disconnect cable W52 (coax 9) from A5J4 and connect this end of cable W52 to the input of a second spectrum analyzer.
3. Set the controls of the second spectrum analyzer connected to cable W52 to the following:
 - Span 5 MHz
 - Reference level -30 dBm
 - Center frequency 10.7 MHz
4. Select each of the fixed-tuned frequencies. Verify at each frequency that the signal amplitude measures -35 dBm. If the frequency is incorrect, do the following:
 - a. Verify that the reference divider output (A4U811 pin 9) is 100 kHz. If it is not, verify that the 10 MHz reference is present at A4U811 pin 1.
 - b. Verify that the frequency found on the output of the divider (A4U808 pin 15) matches the output of the reference divider. Matching frequencies indicate the oscillator loop is locked. If the loop is not locked, troubleshoot the divider, oscillator, or phase detector.
 - c. Verify that the frequency found at the divider input (A4U808 pin 3) matches the CW frequency chosen in step a. Matching frequencies indicate a properly working oscillator. If the frequency is different, troubleshoot the divider.
 - d. Repeat step c for all the CW frequencies provided by the test.
5. Select each of the sweep widths (these sweeps are centered about

10.7 MHz).

6. Reduce the span of the other spectrum analyzer to check that the cal oscillator is actually sweeping. If the oscillator is not sweeping, perform the following steps:
 - a. The output of the sweep generator circuit (A4U804 pin 8 of function block Z) should be a series of negative-going parabolas (frequency and amplitude vary depending on the sweep width chosen). [Table 8-3 on page 414](#) lists the RANGE, MA0, and MA1 values for the sweep widths. If a failure is indicated in the IF/LOG CHECK, press **More Info** to provide more detailed information about the detected failure. If an HP-IB printer is available, connect it to the spectrum analyzer HP-IB connector, then press **Print Page** for a hard-copy output.

Table 8-3 Sweep Width Settings

| Sweep Width | Sweep Time | Res BW Adjusted | RANGE A4U105 Pin 6 | MA1 A4U105 Pin 2 | MA0 A4U105 Pin 5 |
|-------------|------------|-----------------|--------------------|------------------|------------------|
| 20 kHz | 5 ms | 10 kHz | +5 V | 0 V | 0 V |
| 10 kHz | 10 ms | 3 kHz | +5 V | 0 V | +5 V |
| 4 kHz | 30 ms | 1 kHz | +5 V | +5 V | 0 V |
| 2 kHz | 15 ms | 300 Hz | +5 V | +5 V | +5 V |

Automatic IF Adjustment

The spectrum analyzer performs an automatic adjustment of the IF Section whenever needed.

The cal oscillator on the A4 assembly provides a stimulus signal which is routed through the IF during the retrace period.

The A3 Interface assembly measures the response using its analog-to-digital converter (ADC). The spectrum analyzer turns the cal oscillator off during a sweep.

When IF ADJ is ON, the spectrum analyzer readjusts part of the IF circuitry during each retrace period to readjust the IF completely every 5 minutes.

Automatic IF adjustment is performed upon the following conditions:

- Power on: (unless **STOP ALIGN** is pressed). The IF parameter variables are initialized to values loaded in program ROM and all possible IF adjustments are made. If **STOP ALIGN** is pressed, the adjustment is halted.
- If **REALIGN LO &IF** is selected: All possible IF adjustments (and LO adjustments) are made with the most recent IF parameter variables used as the starting point.
- If **FULL IF ADJ** is selected: All possible IF adjustments are made with the most recent IF parameter variables used as the starting point. (**FULL IF ADJ** is located in the **CAL** menu.)
- If **ADJ CURR IF STATE** is selected: All amplitude data and some resolution bandwidths are adjusted. The bandwidths adjusted are a function of the currently selected resolution bandwidth setting.
- Between sweeps: IF ADJ must be set to ON. When IF ADJ is OFF, an A is displayed along the left side of the graticule.

If a **FULL IF ADJ** sequence cannot proceed beyond the amplitude portion, check the output of the cal oscillator on the A4 assembly as follows:

1. Disconnect cable W52 (coax 9) from A5J4. Connect cable W52 to the input of a second spectrum analyzer.
2. Set the second spectrum analyzer center frequency to 10.7 MHz and the reference level to -30 dBm.
3. On the HP 8560E/EC under test, press **FULL IF ADJ** and observe the display of the second spectrum analyzer.
4. If a -35 dBm signal does not appear, the cal oscillator is probably at fault.

Parameters Adjusted

The following IF parameters are adjusted in the sequence listed:

1. Amplitude
 - a. Video Offsets: analog (using log amplifier video offset DAC) and digital (applying stored constant to all readings)
 1. Linear Scale Offset
 2. Log Scale Offset
 1. Wideband and Narrowband modes.
 2. 0 to 60 dB range in 10 dB steps.
 3. 10 dB/DIV and 2 dB/DIV (log expand) modes.
 - b. Step Gains (A5 IF Assembly)
 1. First Step Gain for 16 different DAC settings.
 2. Second Step Gain for 16 different DAC settings.
 3. Third Step Gain for 0, 15, and 30 dB attenuation relative to maximum gain.
 4. Fine Attenuator for 32 evenly-spaced DAC settings.
 - c. Log Amplifier Slopes and Fidelity
 1. Wideband (RES BW 300 kHz through 2 MHz) and Narrowband modes (RES BW 300 Hz through 100 kHz)
 2. 10 dB/DIV and 2 dB/DIV (log expand) modes
 - d. Linear Scale Gains - On the log amplifier assembly (P/O A4)
 - e. Peak Detector Offsets (both Positive and Negative Peak Detectors with respect to normal sample path used by Auto IF Adjust)
2. LC Bandwidths
 - a. 300 kHz resolution bandwidth center frequency, bandwidth, and gain
 - b. 1 MHz resolution bandwidth center frequency, bandwidth, and gain
 - c. 2 MHz resolution bandwidth gain
 - d. 100 kHz resolution bandwidth center frequency, bandwidth, and gain
 - e. 30 kHz resolution bandwidth center frequency, bandwidth, and gain
 - f. Gain of all resolution bandwidth relative to the 300 kHz RES BW

3. Crystal Bandwidths

- a. The cal oscillator sweep rate is measured against the 100 kHz resolution bandwidth filter skirt. This result is used in compensating the sweeps used for adjusting the crystal bandwidths.
 - b. 10 kHz resolution bandwidth
 1. Center frequency of LC tank that loads the crystal
 2. Symmetry adjustment to cancel crystal case capacitance
 3. Bandwidth
 - c. 3 kHz resolution bandwidth: center frequency of LC tank and bandwidth of resolution bandwidth
 - d. 1 kHz resolution bandwidth: bandwidth
 - e. 300 Hz resolution bandwidth: bandwidth
 - f. Gain of all resolution bandwidth relative to the 300 kHz RES BW
4. Digital Bandwidths (1 Hz through 100 Hz; 10 Hz through 100 Hz if Option 103)
- a. VCXO (final LO) tuned to align digital bandwidths with crystal bandwidth center frequency
 - b. Overall gain
 - c. Gain variation with input frequency

Requirements

For the Automatic IF Adjustment routine to work, the spectrum analyzer must provide the following basic functions:

- Power supplies
- Control signals
- ADC
- 10 MHz Frequency Reference to the A4 log amp/cal oscillator
- A15 RF Assembly isolation from the RF signal during IF adjustment

A15 RF assembly isolation is a function of the REDIR signal in the A15 Flatness Compensation Control block.

The references against which the Automatic IF Adjustment routine aligns are:

- 10 MHz reference (A15)
- Linear Scale Fidelity, especially the 10 dB gain stage in A4 Linear Amplifier block.
- 15 dB Reference Attenuator (A5)
- Cal Oscillator output power (A4)

Performance Test Failures

Failures in IF-Section-related performance tests may be investigated using the following information:

IF Gain Uncertainty Performance Test

Failure of this performance test indicates a possible problem with the spectrum analyzer IF gain circuits. Assuming no major IF problems causing IF adjustment errors, IF gain problems in the first 50 dB of IF gain (REF LVLs of 0 dBm to -50 dBm with 10 dB ATTEN) are a result of faults on the A5 IF Assembly. IF gain problems in the next 60 dB of IF gain (REF LVLs of -60 dBm to -110 dBm, 10 dB ATTEN) result from log amplifier faults on the A4 assembly.

A signal level of -5 dBm is required at input (A5J3) for displaying a signal at top screen with 10 dB input attenuation and a 0 dBm reference level. Isolate IF gain problems on the log amplifier assembly (A4) with the following steps:

1. On the spectrum analyzer press **PRESET, SPAN, ZERO SPAN, FREQUENCY, 1 GHz, AMPLITUDE, -50 dBm**.
2. Press **CAL** and **IF ADJ OFF**.
3. Disconnect cable W27 (coax 3) from A5J5 and connect cable W27 to the output of a signal generator.
4. Set the signal generator controls as follows:

| | |
|-----------------|----------|
| Amplitude | +10 dBm |
| Frequency | 10.7 MHz |
5. Simultaneously decrease the signal generator output and the spectrum analyzer REF LVL in 10 dB steps. The signal displayed by the spectrum analyzer should remain at the reference level for each step. If the signal deviates from the reference level, troubleshoot the video offset circuitry on the A4 assembly.
6. Repeat steps 1 through 5 with the spectrum analyzer set to linear.

Scale Fidelity Performance Test

Failure of this performance test indicates a possible problem with the A4 assembly.

If the Linear, 5 dB/DIV, or 10 dB/DIV scales are out of specification, the fault is most likely on the log amplifier assembly (P/O A4).

If only the 1 dB/DIV or 2 dB/DIV scales are out of specification, the fault is most likely on the A3 interface assembly.

Resolution Bandwidths Performance Tests

Most resolution bandwidth problems are a result of A5 IF assembly failures. The resolution bandwidths are adjusted in the following sequence using 300 kHz as the reference: 1 MHz, 2 MHz, 100 kHz, 30 kHz, 10 kHz, 3 kHz, 1 kHz, 300 Hz, 100 Hz, 30 Hz, 10 Hz, 3 Hz, and 1 Hz. The 3 Hz and 1 Hz bandwidths are not available with Option 103.

If the IF adjustment routine encountered an error, the previously adjusted resolution bandwidths should be working properly and default DAC values are used for the remaining resolution bandwidth settings.

If the IF bandpass adjustments and the automatic IF adjustments fail to bring the resolution bandwidths within specification, troubleshoot the A5 IF assembly.

Log Amplifier Assembly (P/O A4)

The log amplifier assembly on A4 performs several functions. It provides log and linear paths converting the 10.7 MHz IF signal to video. In addition it also provides offset circuitry, AM/FM demodulator circuitry, a frequency counter output, and down conversion of the 10.7 MHz IF to 4.8 kHz for use by the digital IF.

The log amp results are realized by using a wide dynamic range linear detector followed by a video log amp. The detector is used for both linear and log paths and contains a mixer that acts as the down converter mixer for the digital IF.

CAUTION

For troubleshooting, it is recommended that you use an active probe, such as an HP 85024A, and another spectrum analyzer. If an HP 1120A active probe is being used with a spectrum analyzer having dc coupled inputs, such as the HP 8566A/B, HP 8569A/B and the HP 8562A/B, either set the active probe for an ac-coupled output or use a dc-blocking capacitor between the active probe and the spectrum analyzer input. Failure to do this can result in damage to the spectrum analyzer or the probe.

Log Amplifier

Refer to function blocks K, L, and AE of A4 Log Amplifier Schematic Diagram in the *HP 8560 E-Series Spectrum Analyzer Component Level Information*. The log amplifier receives the detected video signal from the Detector/Mixer and outputs a voltage proportional to the log of the input voltage. The linear output is tapped off at the emitter of U501D. U507 provides input offset adjustment capability and adjusts the offset of the op amp formed by U501A, B, C, and D. Q502 is a buffer. Q501 switches in additional offset for digital RBWs. The logarithmic characteristic of the base-emitter junction of U502B is used in the feedback path to produce the logging affect. U502D is used to adjust for non-linearities in the linear mode. R531 is used to adjust log fidelity at the top of the screen.

Use the following steps to verify proper operation of the log amplifier chain:

1. Press **CAL** and **IF ADJ OFF**. Set the digital multimeter to read dc volts and connect the negative lead to the chassis of the spectrum analyzer.
2. Remove W27 from A4J3 and inject a 10.7 MHz signal of +10 dBm into A4J3.
3. Set the spectrum analyzer to log mode, with a resolution bandwidth of 300 kHz and single sweep.

4. Using the DMM, check the voltage at U503 pin 6.
5. Verify that this level is about -700 mV.
6. Adjust the source amplitude to place the signal at the reference level.
7. Reduce the input signal level in 10 dB steps, down to -60 dBm, while noting the voltage displayed on the DMM. The voltage should increase (become less negative) at a rate of 30 mV for each 10 dB decrease in input power. Troubleshoot the A4 assembly if the signal does not decrease properly.
8. Set the spectrum analyzer resolution bandwidth to 100 kHz to place the wide/narrow filter in narrow mode.
9. Repeat steps 2 through 7.
10. If log fidelity is poor near the bottom of the screen or the 1 MHz resolution bandwidth is narrow, a fault might exist in the wide/narrow filter switch. (Refer to function block G of A4 log amplifier schematic diagram in the *HP 8560 E-Series Spectrum Analyzer Component Level Information*.) Check this switch as follows:
 - a. Monitor voltages on A4U302 pins 1 and 7 while changing the spectrum analyzer resolution bandwidth from 100 kHz to 300 kHz.
 - b. If the voltages do not come within a few volts of the +15 V and -15 V supplies, U103 and U302 are suspect.
 - c. Disconnect the digital multimeter and reconnect W27 to A4J3.

Linear Amplifiers

Refer to function block C of A4 log amplifier schematic diagram (sheet 2 of 4) in the *HP 8560 E-Series Spectrum Analyzer Component Level Information*. The Linear Amps consist of two variable gain stages, U201C and U201E as well as the buffer amplifier A4U201B, A4U201D, and A4Q201. The linear amplifiers provide 0 to 40 dB of IF gain in 10 dB steps. The gain of A4U201C can be increased by 20 dB by turning on A4CR201 and A4CR210 with the control line LIN_20B. The gain of A4U201E can be increased by either 10 dB or 20 dB with the control lines LIN_10 or LIN_20A respectively. The gain can be selected by setting the spectrum analyzers reference level.

Table 8-4 IF Gain Application Guidelines (ATTEN=10 dB)

| Power into A4J3 | Reference Level | Gain of A4U201C (Pin 8 in; Pin 3 out) | Gain of A4U201 (Pin 3 in; Pin 10 out) | Total Gain |
|-----------------|-----------------|---------------------------------------|---------------------------------------|------------|
| +6 dBm | -50 dBm | 0 dB | 0 dB | 0 dB |
| -4 dBm | -60 dBm | 0 dB | 10 dB | 10 dB |
| -14dBm | -70 dBm | 0 dB | 20 dB | 20 dB |
| -24 dBm | -80 dBm | 20 dB | 10 dB | 30 dB |
| -34 dBm | -90 dBm | 20 dB | 20 dB | 40 dB |

Total gain can be measured by injecting the specified power into A4J3 and measuring the total gain provided by A4U201C and A4U201E. The following procedure provides a means of troubleshooting the linear amplifiers:

1. On the spectrum analyzer, press **PRESET, SPAN, ZERO SPAN, CAL, IF ADJ OFF, FREQUENCY, 1 GHz, AMPLITUDE, -50 dBm, LINEAR, MORE, AMPTD UNITS, dBm, and AMPLITUDE.**
2. Disconnect W27 (coax 3) from A4J3 and connect the output of a signal generator to A4J3.
3. Set the signal generator controls as follows:
 - Amplitude +6 dBm
 - Frequency 10.7 MHz
4. Simultaneously decrease the signal generator output and spectrum analyzer REF LVL in 10 dB steps to -90 dBm. At each step, the signal displayed on the spectrum analyzer should be within one division of the previous position.
5. If a problem exists, isolate it by comparing the actual gain of A4U201C and A4U201E with those listed in the gain guidelines, above.
6. Reconnect W27 (coax 3) to A4J3.

Video Offset

Refer to function block P of A4 log amplifier schematic diagram (sheet 3 of 4) in the *HP 8560 E-Series Spectrum Analyzer Component Level Information*.

The circuit provides a programmable video offset, with a step size of 5 mV, from -300 mV to +900 mV.

1. On the spectrum analyzer, press **PRESET, SPAN, ZERO SPAN, FREQUENCY, 1 GHz, AMPLITUDE, -50 dBm, CAL, IF ADJ OFF.**
2. Disconnect W27 (coax 3) from A4J3 and connect a signal generator to A4J3.

3. Set the signal generator controls as follows:

Amplitude +10 dBm
Frequency 10.7 MHz

4. Simultaneously decrease the signal generator output and spectrum analyzer reference level in 10 dB steps down to -110 dBm. At each step, the signal displayed on the spectrum analyzer should be close to the reference level.
5. Reconnect W27 (coax 3) to A4J3 and cycle the spectrum analyzer power. Press **STOP REALIGN** when it appears.
6. On the spectrum analyzer, press **SWEEP, SINGLE, CAL,** and **IF ADJ OFF.**
7. The offset DAC, A4U102 pin 2, should now be at its default value of approximately +2.45 V. The voltage at U601 pin 3 should be approximately 0 V for a DAC output of 2.45 V.
8. If this default offset voltage is incorrect, DAC U102 is the most probable cause.

Video Output

1. On the spectrum analyzer, press **PRESET, FREQUENCY, 300 MHz, SPAN, 100 Hz, AMPLITUDE, -10 dBm, SGLSWP, CAL** and **IF ADJ OFF.**
2. Connect the CAL OUTPUT to the INPUT 50 Ω connector.
3. Disconnect W54 (coax 2) from A4J4. Connect a short SMB to SMB cable from A4J4 to an SMB tee and connect W54 to the tee. Connect a test cable from the tee to the input of an oscilloscope.
4. Set the oscilloscope controls as follows:

Amplitude scale 200 mV/div
Offset +400 mV
Coupling dc
Sweep time 50 μ s/div
5. The oscilloscope should display a 4.8 kHz sine wave.
6. Disconnect the cable from the CAL OUTPUT and the INPUT 50 Ω connectors.
7. Set the resolution bandwidth to 2 MHz.
8. Broadband noise should be displayed on the oscilloscope from approximately +200 mV to +400 mV.
9. As the **REF LVL** is decreased in 10 dB steps from -10 dBm to -70 dBm, the noise displayed on the oscilloscope should increase in 100 mV increments. If this response is not observed, refer to "Step Gains" and "Video Offset" in this chapter.

10.Reconnect cable W54 to A4J4.

Frequency Counter Prescaler/Conditioner

Refer to function block Q of A4 log amplifier schematic diagram (sheet 4 of 4) in the *HP 8560 E-Series Spectrum Analyzer Component Level Information*.

The frequency counter prescaler/conditioner divides the frequency by two, and then attenuates it. The circuit consists of frequency divider (U703A) and an output attenuator. The frequency divider turns on only when the instrument is counting.

AM/FM Demodulator

Refer to function block R of A4 Log Amplifier Schematic Diagram (sheet 4 of 4) in the *HP 8560 E-Series Spectrum Analyzer Component Level Information*.

The demodulator circuitry on the log amplifier on A4 produces a low-level audio signal. This audio signal is then amplified by the audio amplifier on A4. The FM demodulator demodulates narrowband FM (5 kHz deviation) signals. The detector demodulates AM signals.

1. If demodulation problems occur when the spectrum analyzer is in the frequency domain, perform the Frequency Span Accuracy performance test and, if necessary, the YTO Adjustments procedure.
2. If an FM signal cannot be demodulated, perform the Demodulator Adjustment procedure. If the output of A4C707 cannot be adjusted as described in the Demodulator Adjustment procedure, troubleshoot the FM Demodulator or Audio MUX circuits on A4.

4.8 kHz IF Filters

Refer to function block N of A4 Log Amplifier Schematic Diagram (sheet 3 of 4) in the *HP 8560 E-Series Spectrum Analyzer Component Level Information*.

Problems with the 4.8 kHz filters can result in spurious signals appearing 2.88 kHz to 3.52 kHz greater than the frequency of the desired response. Also, ERR 536 RBW <300 may occur when problems exist with the 4.8 kHz IF filters.

Measure the passband of the 4.8 kHz IF Filters as described in the following procedure:

1. On the spectrum analyzer, press **CAL**, **IF ADJ OFF**, **SPAN**, and 600 Hz.
2. Disconnect W27 from A4J3 and inject a 10.7 MHz signal of -20 dBm into A4J3.
3. Fine-tune the frequency of the signal generator to center the signal on the screen. Set the signal generator to sweep one 2 kHz span about this center frequency. Press **SGL SWP** on the HP 8563E.
4. Set another spectrum analyzer, such as the HP 8566A/B, to 4.8 kHz center frequency and 2 kHz span.

CAUTION

If a dc block is not used, damage to the HP 8566A/B results. The HP 8566A/B and many other spectrum analyzers have dc-coupled inputs and cannot tolerate dc voltages on their inputs.

5. Connect the VIDEO OUTPUT (rear panel) of the spectrum analyzer through a 20 dB attenuator and dc block to the input of the HP 8566A/B. Set the sweep time of the HP 8566A/B to 10 seconds.
6. Set the HP 8566A/B to single trigger and press **TRACE A CLEAR-WRITE**. Trigger a sweep of the HP 8566A/B and the signal generator simultaneously. The HP 8566A/B shows the passband of the 4.8 kHz IF filters. The 3 dB bandwidth of the filters should be 1.2 kHz. The passband of the filters should be flat within 2 dB over 800 Hz.
7. Reconnect W27 (coax 3) to A4J3.

10.7 MHz IF Filters

1. Press **PRESET**, **FREQUENCY**, 300 MHz, **SPAN**, 600 Hz, **CAL**, and **IF ADJ OFF**.
2. Disconnect W29 (coax 7) from A5J3. Set the signal generator for a 10.7 MHz signal at -50 dBm and connect it to A5J3.
3. Fine tune the frequency of the signal generator to center the signal on the HP 8560E/EC display. Set the signal generator to sweep one 2 kHz span about this center frequency.

4. On the HP 8560E/EC, press **SGL SWP**.
5. Disconnect W27 (coax 3) from A5J5. Connect a test cable from A5J5 to the input of an HP 8566A/B.
6. Set the HP 8566A/B as follows:
Center frequency 10.7 MHz
Span 2 kHz
Reference level +10 dBm
Sweep Single
7. Press TRACE A **CLEAR-WRITE** on the HP 8566A/B.
8. Trigger a sweep on the signal generator and on the HP 8566A/B simultaneously. The HP 8566A/B should display a 3 dB bandwidth of approximately 500 Hz.
9. Reconnect W27 (coax 3) to A5J5 and W29 (coax 7) to A5J3.

4.8 kHz and 10.7 MHz IF Filters

1. On the HP 8560E/EC, press **PRESET, FREQUENCY, 300 MHz, SPAN, 600 Hz, CAL, and IF ADJ OFF**.
2. Disconnect W29 (coax 7) from A5J3. Set the signal generator for a 10.7 MHz signal at -60 dBm and connect it to A5J3.
3. Fine tune the frequency of the signal generator to center the signal on the HP 8560E/EC display. Set the signal generator to sweep one 2 kHz span about this center frequency.
4. On the HP 8560E/EC, press **SGL SWP**.
5. Set the HP 8566A/B to 4.8 kHz center frequency and 2 kHz span.

CAUTION

Damage to the HP 8566A/B results if a dc block is not used. The HP 8566A/B and many other spectrum analyzers have dc-coupled inputs and cannot tolerate dc voltages on their inputs.

6. Connect the VIDEO OUTPUT (rear panel) of the spectrum analyzer through a 20 dB attenuator and dc block to the input of the HP 8566A/B. Set the sweep time of the HP 8566A/B to 10 seconds.
7. Set the HP 8566A/B to single trigger and press TRACE A **CLEAR-WRITE**. Trigger a sweep on the HP 8566A/B and on the signal generator simultaneously. The HP 8566A/B should show a 3 dB bandwidth of 600 Hz \pm 100 Hz.
8. Reconnect W29 (coax 7) to A5J3.

10.6952 MHz VCXO

Refer to function block E of A4 log amplifier schematic diagram (sheet 2 of 4) in the *HP 8560 E-Series Spectrum Analyzer Component Level Information*.

The purpose of the 10.6952 MHz voltage-controlled crystal oscillator (VCXO) is to provide an LO for down-converting the peak of the 10.7 MHz IF filter passband to 4.8 kHz. Since the peak of the passband of the 10.7 MHz IF filters is 10.7 MHz \pm 300 Hz, the frequency of the VCXO is between 10.6949 MHz and 10.6955 MHz. This frequency can best be measured at the collector of A4Q202.

The center frequency of the 300 Hz resolution-bandwidth filters and the 1 Hz to 100 Hz filters should differ no more than 10 Hz. If the center frequency is different by more than this, or if no signal is present in the 1 Hz to 100 Hz resolution-bandwidth settings, troubleshoot the 10.6952 MHz VCXO.

Error message ERR 539 may occur if the VCXO is not oscillating. If problems exist with the VCXO control voltage, error messages ERR 536 or ERR 530 may occur.

Between sweeps the VCXO, at times, is turned off. To prevent the oscillator from turning off, press **PRESET**, **FREQUENCY**, **0.3 GHz**, **SPAN**, **1 kHz**, **SGL SWP**, **CAL**, and **IF ADJ OFF**.

Input Switch

Refer to function block D of A4 Log Amplifier Schematic Diagram (sheet 2 of 4) in the *HP 8560 E-Series Spectrum Analyzer Component Level Information*.

The input switch switches between log and linear modes. In addition it contains a 20 dB attenuator which is used only in digital resolution bandwidth settings. CR207, CR208, and CR209 form the input switch. CR205 and CR206 switch in R234 when in linear mode to maintain a constant impedance at J3. CR210, CR211, CR212, and CR221 switch the 20 dB attenuator in and out.

LO Switch

Refer to function block F of A4 Log Amplifier Schematic Diagram (sheet 2 of 4) in the *HP 8560 E-Series Spectrum Analyzer Component Level Information*.

The LO switch switches the limiter input between the 10.7 MHz path or the 10.6952 MHz VCXO path.

Synchronous Detector

A wide dynamic range linear detector is realized by the limiter (block G), the isolation amplifier (block H), the LO amplifier (block I), and the detector/mixer (block J). The combination of these circuits form what is commonly known as a synchronous detector.

The input signal is split between two paths. One path flows through the isolation amplifier and the other path flows through the limiter and LO amplifier. The path flowing through the limiter generates the LO for the detector/mixer block. The path through the isolation amplifier drives the RF port.

To troubleshoot this group of circuits set the RBW to 300 kHz. Inject 10.7 MHz at +6 dBm into J3. Probe the gate of A4Q404 or A4Q405 with a scope. Look for a 0 to -3 V square wave. Decrease the input power from +6 dBm to -84 dBm in 10 dB steps. The square wave signal should remain unchanged. It is normal for the phase of the signal to jitter at the lowest signal levels.

The signals at the gates of A4Q404 and A4Q405 should be 180 degrees out of phase from each other. If they are not 180 degrees out of phase or one of the signals are not present, troubleshoot the LO Amplifier or the FETs in the mixer. If the signal is not a symmetrical square wave, troubleshoot the LO amplifier. If the signal drops out prematurely or is not present at all, troubleshoot the limiter or LO amplifier.

Repeat the procedure for an $RBW \leq 100$ kHz. If the log amplifier works in the 300 kHz RBW but not in the narrower RBWs, troubleshoot the log narrow filter in the limiter or isolation amplifier. A4CR302 and A4CR303 are varactor diodes in the limiter filter and are used to tune the filter.

Limiter

Refer to function block G of A4 Log Amplifier Schematic Diagram (sheet 2 of 4) in the *HP 8560 E-Series Spectrum Analyzer Component Level Information*.

The limiter consists of 7 identical 20 dB gain stages. A "log narrow filter" is switched in for RBWs ≤ 100 kHz. This filter is switched in using the control lines NARROW between the 4th and 5th stages. During normal operation, the limiter serves to amplify even the smallest 10.7 MHz signals up to a level sufficient to drive the LO Amplifier and subsequent detector/mixer. This signal serves as the LO for the mixer circuitry.

Isolation Amplifier

Refer to function block H of A4 Log Amplifier Schematic Diagram (sheet 3 of 4) in the *HP 8560 E-Series Spectrum Analyzer Component Level Information*.

The isolation amplifier prevents LO port to RF port feedthrough in the mixer from feeding back to the input of the limiter and causing loop oscillations. In addition, the isolation amplifier matches the phase of the non-limited signal path to the phase of the limited signal path. The isolation amplifier should have a gain of about 4 dB and also has a "log narrow filter" that is switched with the control line NARROWB.

Detector/Mixer

Refer to function block J of A4 Log Amplifier Schematic Diagram (sheet 3 of 4) in the *HP 8560 E-Series Spectrum Analyzer Component Level Information*.

Sum and difference frequencies are produced in the Detector/Mixer. The difference frequency produces video (dc to approximately 3 MHz), since the two signals are at the same frequency. During digital resolution bandwidths the two signals are separated by about 4.8 kHz.

Log Offset/Gain Compensation

Refer to function blocks L and M of A4 Log Amplifier Schematic Diagram (sheet 3 of 4) in the *HP 8560 E-Series Spectrum Analyzer Component Level Information*.

Log Offset Compensation

The gain of A4U503 is set to unity, with A4R539 and A4R540 combining for a gain of 0.5. Therefore, the gain from A4U503 pin 3 to A4U508 pin 3 should be 0.5.

Log Gain Compensation

The gain of A4U508 is nominally 6.8, measuring from pin 3 to pin 8. To check the log offset/gain compensation circuits, inject a +10 dBm signal into J3 with the spectrum analyzer set to log mode. Measure A4U503 pin 3, $V_{in}(1)$ and A4U508 pin 3, $V_{out}(1)$ and record the results. Decrease the input level to -40 dBm and make the same measurements recording $V_{in}(2)$ and $V_{out}(2)$.

The gain is then:

$$\frac{(V_{OUT}(1) - V_{OUT}(2))}{(V_{IN}(1) - V_{IN}(2))}$$

This gives an offset-independent gain measurement.

Video MUX

The video MUX switches the video output between linear, log and 4.8 kHz IF (for digital RBWs). The demod video is an unused feature. The easiest way to troubleshoot this circuit is to look for blown FETs. Bad FETs are characterized by having significant gate current. Only one of the signal lines LIN_VIDEO, IF_VIDEO or LOG_VIDEO should be high (+15 V) at any given time. The others should be low (–15 V). Also look for a voltage drop of several volts across the gate resistors R601, R605, R609, or R613 when in either the off or on state. This indicates gate current and thus a bad FET.

A5 IF Assembly

The input switch connects the IF to either the cal oscillator on the A4 assembly or the 10.7 MHz IF output from the A15 RF assembly. The automatic IF adjustment uses the cal oscillator on A4 at instrument turn-on and between sweeps to align the IF filters and step-gain amplifiers. During sweeps the input switch selects the 10.7 MHz IF output from A15. The LC filters are variable-bandwidth filters that provide resolution bandwidths from 30 kHz to 2 MHz. The automatic IF adjustment sets the bandwidths and center frequencies of each filter stage.

The crystal filters are variable-bandwidth filters that provide resolution bandwidths from 300 Hz to 10 kHz. The automatic IF adjustment sets the filter bandwidths and symmetry.

The step-gain amplifiers consist of the first step-gain stage, second step-gain stage, and third step-gain stage. These amplifiers provide gain when the spectrum analyzer reference level is changed. The amplifiers also provide gain range to compensate for variations in the IF filter gains, which change with bandwidth and environmental conditions, and band conversion loss in the front end. Fixed-gain amplifiers shift the signal levels to lower the noise of the IF chain.

The assembly has two variable attenuators. The fine attenuator provides the 0.1 dB reference level steps. The reference 15 dB attenuator provides a reference for automatic adjustment of the step-gain amplifiers and the log amplifier. The reference 15 dB attenuator also provides gain for changes in spectrum analyzer reference level.

Various buffer amplifiers provide a high-input impedance to prevent loading of the previous filter pole and a low-output impedance to drive the next filter pole.

Digital control signals from the W2 control cable, the "analog bus," drive the control circuitry. At the beginning of each sweep, the analog bus sets each control line for instrument operation. At the end of each sweep, the analog bus sets each control line for the next portion of the automatic IF adjustment routine. IF adjustments continuously remove the effects of component drift as the spectrum analyzer temperature changes.

The assembly contains a reference limiting amplifier. This amplifier provides a known amount of limiting for the automatic IF adjustment routines. (Limiting occurs only during the automatic IF adjustment routines.) The LC34_Short switches are open during sweeps. The current in the reference limiter is increased during sweeps to prevent limiting.

CAUTION For troubleshooting, it is recommended that you use an active probe, such as an HP 85024A, and another spectrum analyzer. If an HP 1120A active probe is being used with a spectrum analyzer having dc-coupled inputs, such as the HP 8566A/B, HP 8569A/B and the HP 8562A/B, either set the active probe for an ac-coupled output or use a dc-blocking capacitor between the active probe and the spectrum analyzer input.

CAUTION Do not short control voltages to ground. These voltages are not short-circuit protected. DACs damaged by shorting these voltages might not fail until several weeks after the shorting takes place.

Do not short power-supply voltages to ground. The spectrum analyzer power-supply current limiting cannot protect the resistors in series with the power supply.

NOTE Some transistors have collectors connected to the case. Electrical connection of the case to the collector might not be reliable, making collector voltage measurements on the transistor case unreliable.

IF Signature

1. Disconnect W27 (coax 3) from A5J5.
2. Connect an SMB tee to A5J5, using a short coaxial cable with SMB connectors.
3. Connect one output of the tee to cable W27 (coax 3).
4. Connect an HP 85024A active probe, with a 10:1 divider installed, to the other output of the tee.
5. Connect the output (type N connector) of the active probe to the input of the HP 8566A/B spectrum analyzer.
6. Connect the probe power cable to the HP 8560E/EC front panel PROBE POWER connector (you may need to use a probe power extension cable, HP 10131B).
7. Set the HP 8566A/B controls as follows:

| | |
|----------------------------|----------|
| Reference level | +10 dBm |
| Center frequency | 10.7 MHz |
| Span | 0 Hz |
| Resolution bandwidth | 300 kHz |
| Video bandwidth | 300 kHz |
| Sweep time | 5.5 s |
| Trigger | Single |
8. On the HP 8566A/B, press **SHIFT** (trace A blank) to set detector to SAMPLE mode.

9. On the HP 8560E/EC, press **PRESET** and set the controls as follows:

Center frequency 300 MHz
Span 5 MHz

10. On the HP 8560E/EC, press **SGL SWP** and **CAL**.

11. Simultaneously press **SINGLE** on the HP 8566A/B and **ADJ CURR IF STATE** on the HP 8560E/EC. The IF signature is displayed on the HP 8566A/B display. It may be necessary to experiment with different time intervals between initiating the sweep on the HP 8566A/B and initiating the current IF state adjustment on the HP 8560E/EC.

12. Compare the IF signature to the signature of a properly operating spectrum analyzer illustrated in [Figure 8-3 on page 435](#). If the signatures do not closely resemble each other, a more detailed view of the signature may show the failed hardware.

a. Set the HP 8566A/B controls as follows:

Sweep time 550 ms
dB/DIV 5 dB
Reference level - 5 dBm

b. Press **SINGLE** on the HP 8566A/B and, a very short time later, press **ADJ CURR IF STATE** on HP 8560E/EC. [Figure 8-4 on page 436](#) through [Figure 8-8 on page 440](#) illustrate detailed IF signatures of a properly operating HP 8560E/EC. It may be necessary to experiment with different time intervals between initiating the sweep on the HP 8566A/B and initiating the current IF state adjustment on the HP 8560E/EC to obtain the waveforms shown. Note the changes in the HP 8566A/B video bandwidth and sweep time.

13. Reconnect W27 (coax 3) to A5J5.

Figure 8-3 IF Adjust Signature

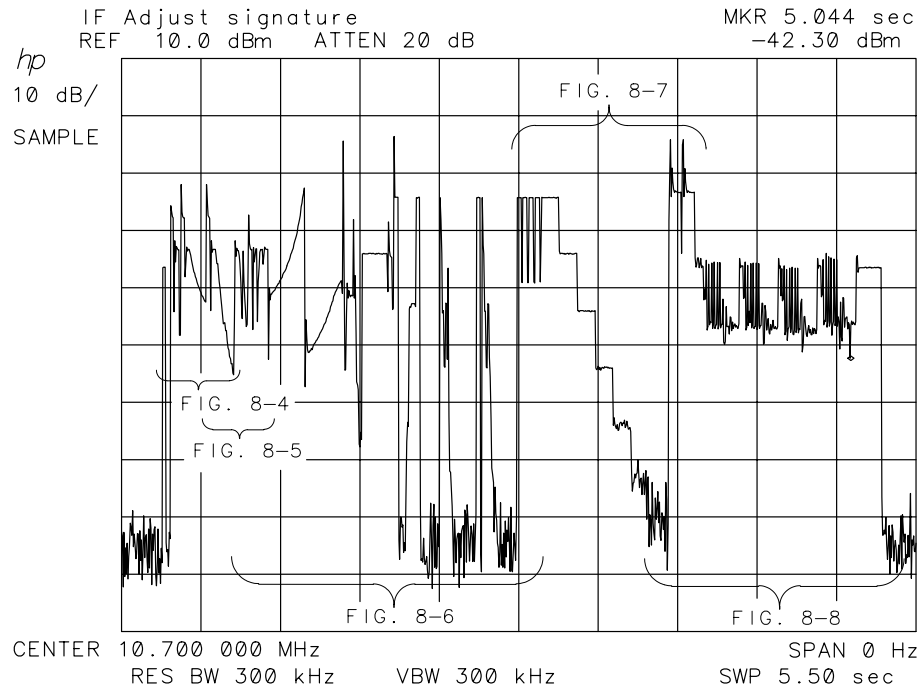

sp1

Figure 8-4 Detailed IF Adjust Signature (1)

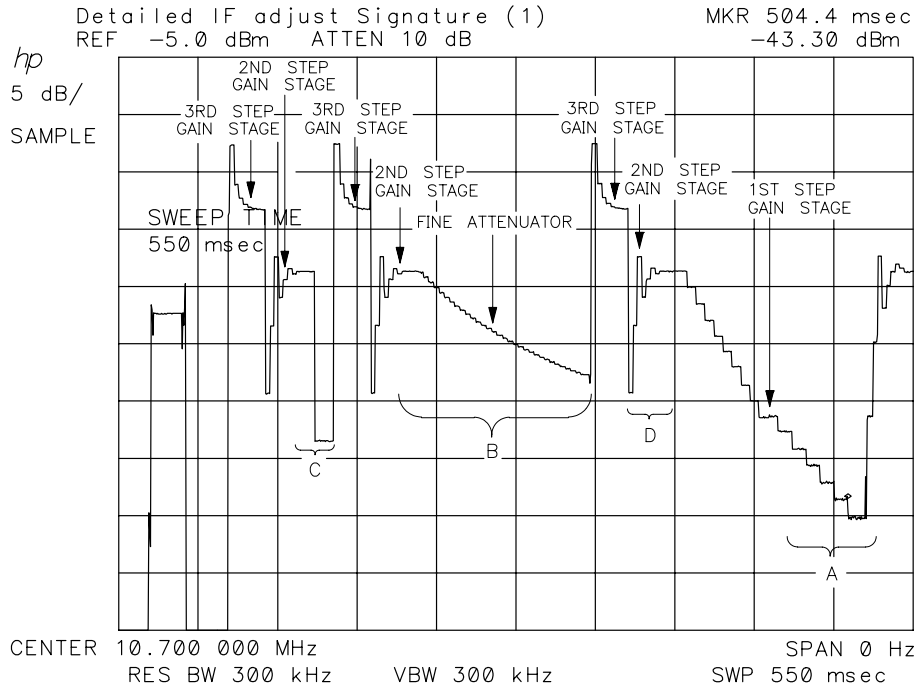

sp1

Figure 8-5 Detailed IF Adjust Signature (2)

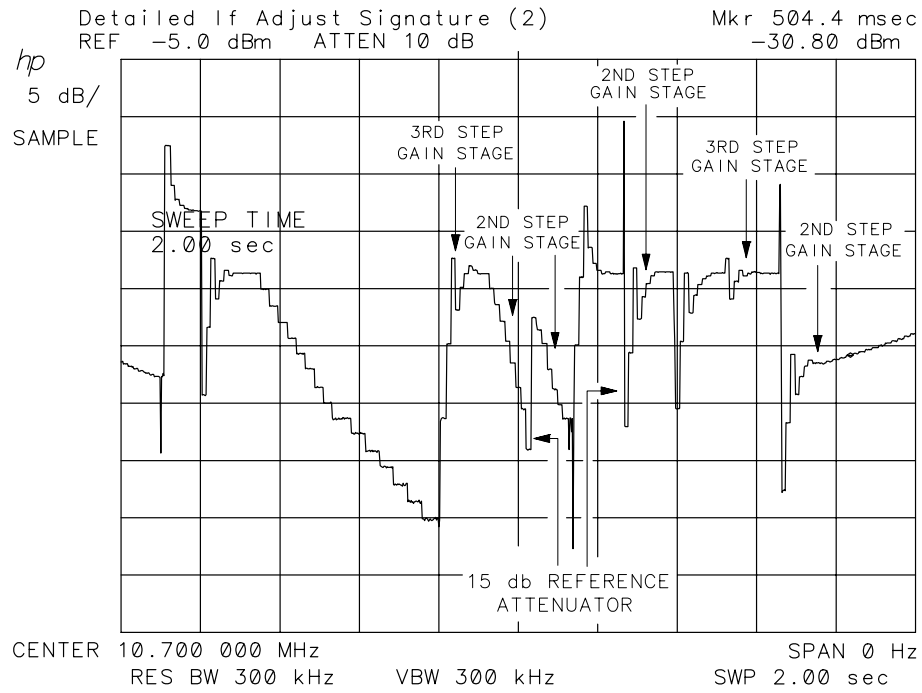

sp1.

Figure 8-6 Detailed IF Adjust Signature (3)

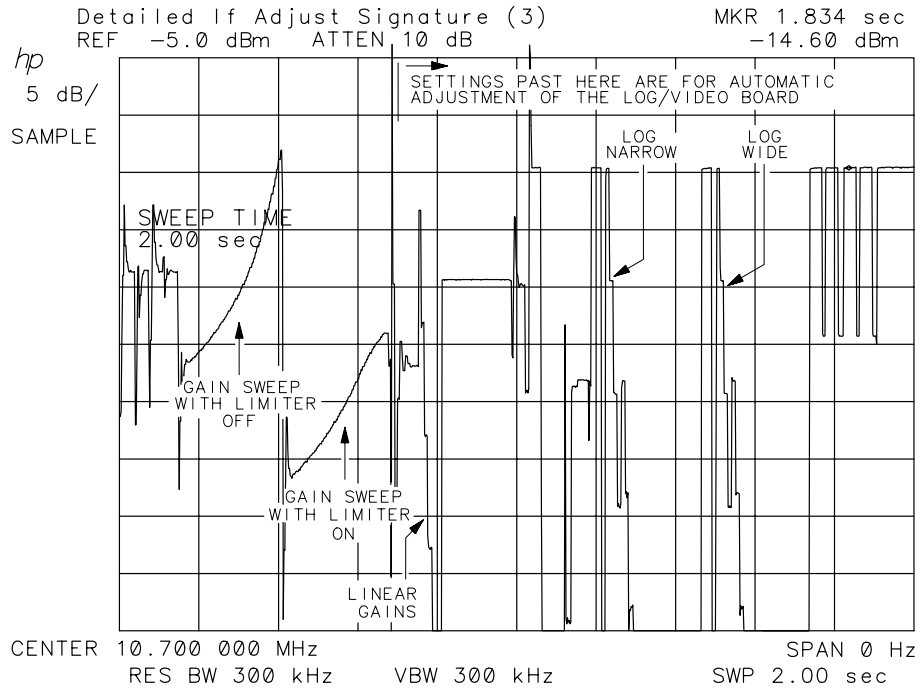

sp

Figure 8-7 Detailed IF Adjust Signature (4)

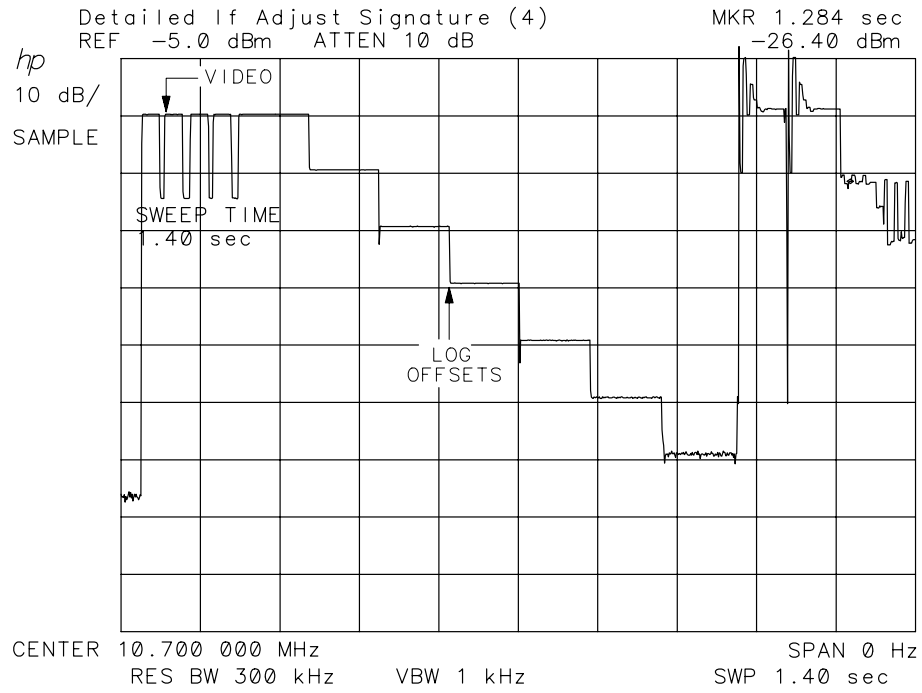

sp1

Figure 8-8 Detailed IF Adjust Signature (5)

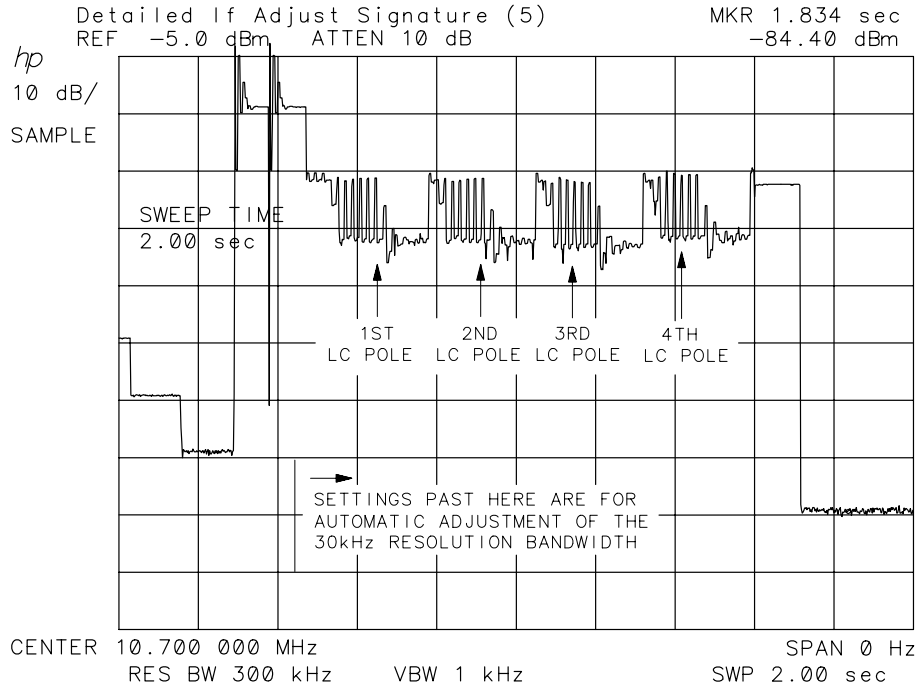

sp

Common IF Signature Problems

Region A of Figure 8-4 on page 436 is noisy:

Suspect the first LC pole.

Region B of Figure 8-4 on page 436 is flat:

Suspect the third step-gain stage, the fine attenuator, or the fourth LC-pole output amplifier.

Region C of Figure 8-4, “Detailed IF Adjust Signature (1),” has no 15 dB step:

Suspect the reference 15 dB attenuator.

Region D of Figure 8-4 on page 436 is flat:

Suspect the second step-gain stage.

Entire signature noisy:

If the signature resembles Figure 8-9 on page 442, suspect a broken first step-gain stage or a break in the signal path in the input switch, first crystal pole, or second crystal pole.

Correct shape but noisy:

If the signature resembles Figure 8-10 on page 443, suspect the second crystal-pole output amplifier.

Amplitude of Region B of Figure 8-11 on page 444 varies more than 12 dB:

Suspect the third step-gain stage output amplifier.

Region B of Figure 8-12 on page 445 is kinked:

Suspect the fourth LC-pole output amplifier.

Figure 8-9 **Noisy Signature**

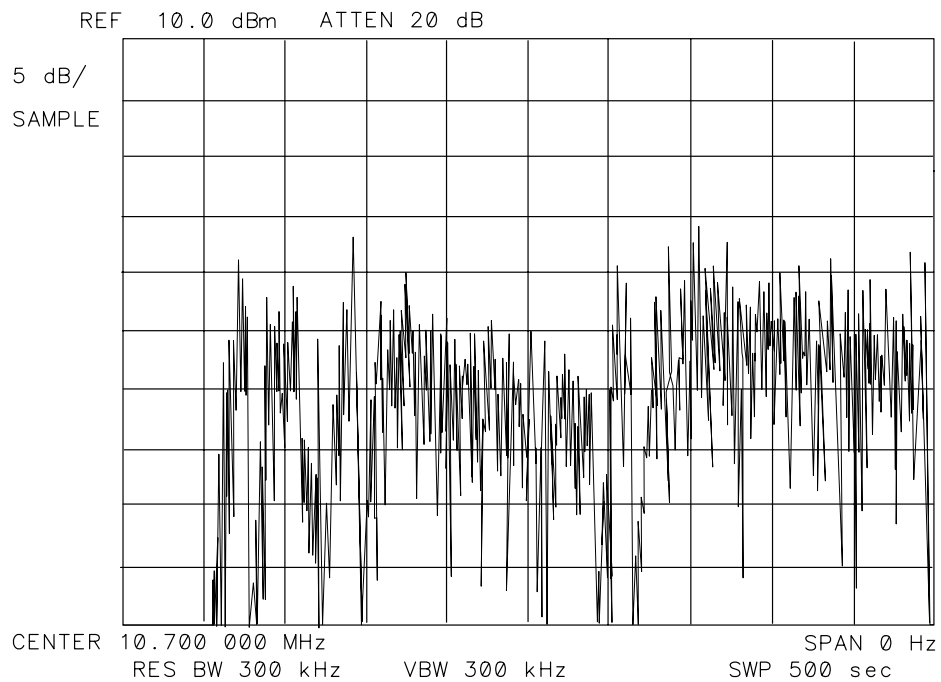

SK178

Figure 8-10 **Noise with Correct Shape**

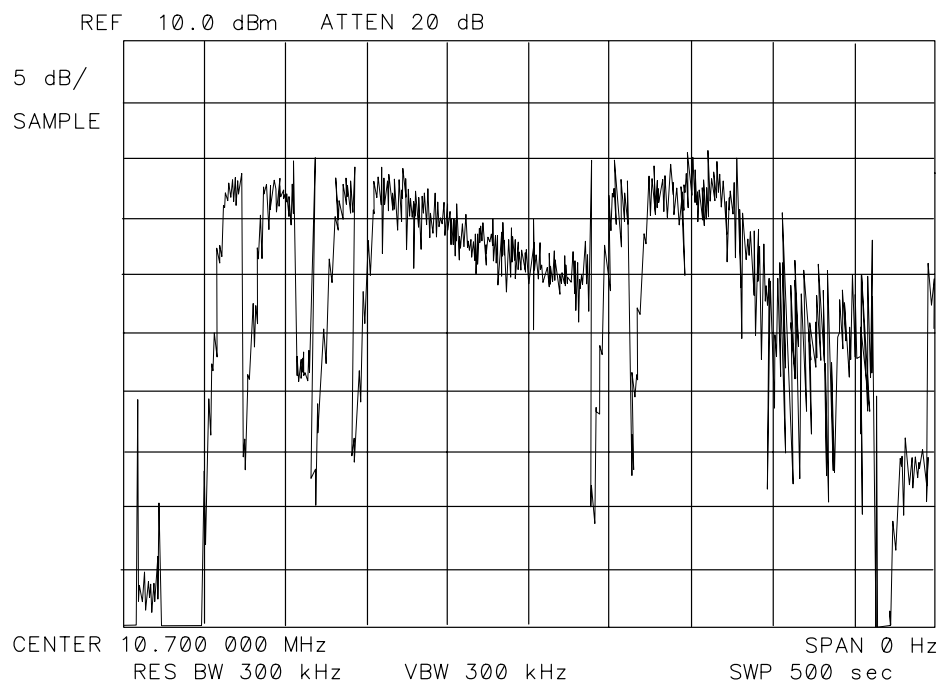

SK179

Figure 8-11 Region B Amplitude Variation

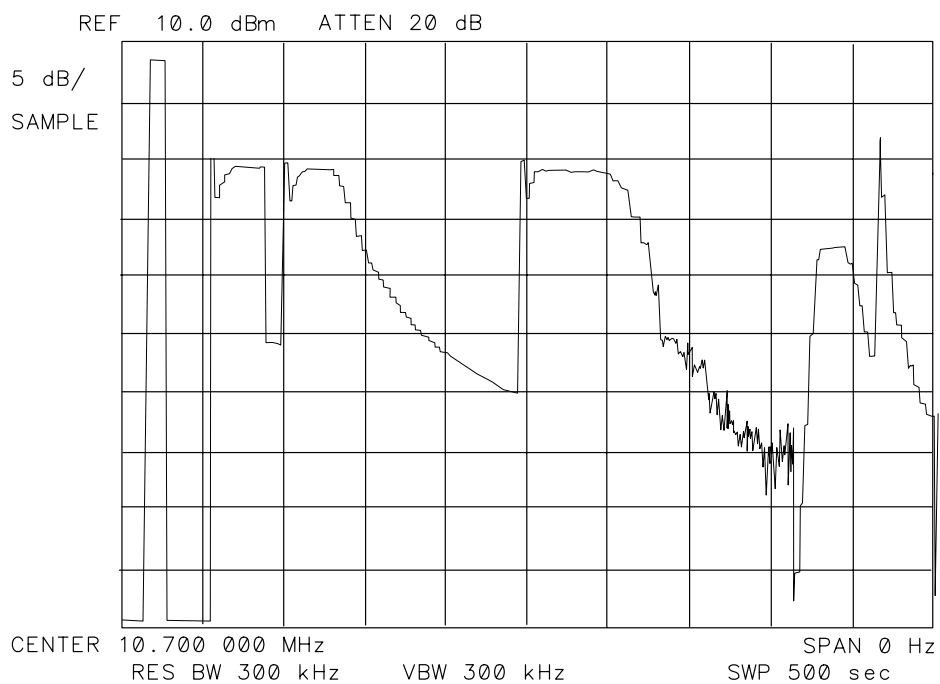

SK180

Figure 8-12 Region B Amplitude Offset

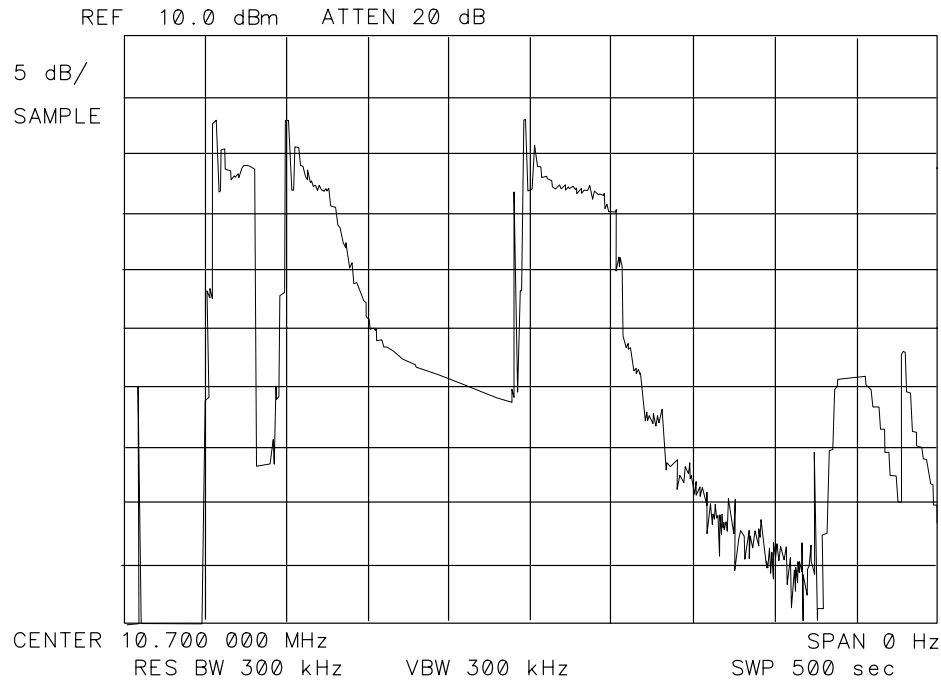

SK181

1 MHz Resolution Bandwidth Problems

Check the crystal shorting switches as follows:

1. On the spectrum analyzer, press **PRESET** and set the controls as follows:

| | |
|----------------------------|---------|
| Resolution bandwidth | 1 MHz |
| Span | 500 kHz |
| Center frequency | 300 MHz |
2. On the spectrum analyzer, connect the 300 MHz CAL OUTPUT to the INPUT 50 Ω
3. If the trace flatness is not within 2.5 dB, a failure probably exists.
4. A trace similar to [Figure 8-13 on page 446](#) indicates a crystal short failure.
5. Press **SPAN** to set the spectrum analyzer to 3 MHz. A trace that slopes across the screen (see [Figure 8-14 on page 447](#)) indicates a failed LC pole. To isolate the broken pole refer to the shape factor information in "30 kHz Resolution Bandwidth Problems."

Figure 8-13 **Faulty Crystal Short**

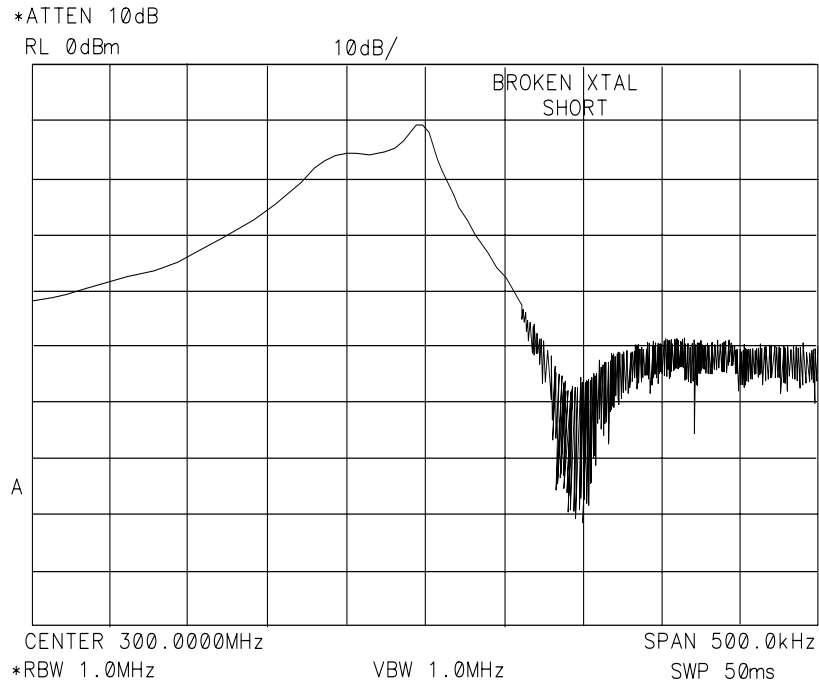

SK182

Figure 8-14 **Faulty LC Pole**

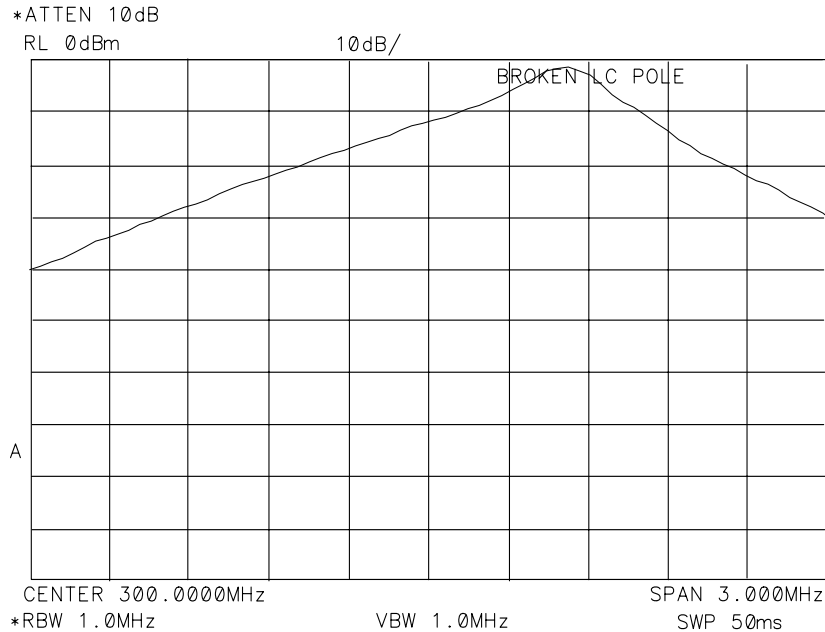

SK183

30 kHz Resolution Bandwidth Problems

Shape factor too high: Shape factor is the ratio of the 60 dB bandwidth to the 3 dB bandwidth. Shape factor should be less than 15:1. If one of the LC poles malfunctions, the shape factor may be the only indication of the failure. Isolate the non-functioning pole with the IF signature. Region E of [Figure 8-8 on page 440](#) illustrates the four LC-pole adjustments. Take several signatures to examine the LC-pole adjustments. If one of the four sections of Region E is consistently longer than the others, the corresponding LC pole is faulty.

IF gain compression: FET transistors Q301, Q303, Q700, and Q701 can deteriorate with age. Measuring less than 0 volts on the FET source indicates a bad FET.

Bandwidth too wide: Check for contamination on the printed-circuit board. Clean the board as required.

3 kHz and 10 kHz Resolution Bandwidth Problems

Asymmetric Filter Response: Check the crystal symmetry control with the following steps:

1. Press **PRESET**.
2. Set the spectrum analyzer controls as follows:
Resolution bandwidth 3 kHz
Span 100 kHz
Center frequency 300 MHz
3. On the spectrum analyzer, connect the 300 MHz CAL OUTPUT to the INPUT 50 Ω
4. A trace similar to [Figure 8-15 on page 448](#) indicates a failed crystal-symmetry circuit.

Narrow 10 kHz resolution bandwidth: Check for printed-circuit board contamination. Clean the board as required.

IF Gain Compression in 10 kHz resolution bandwidth: FET transistors Q202, Q203, Q501, and Q503 can deteriorate with age. Measuring less than 0 volts on the FET source indicates a bad FET.

Figure 8-15 **Faulty Crystal Symmetry**

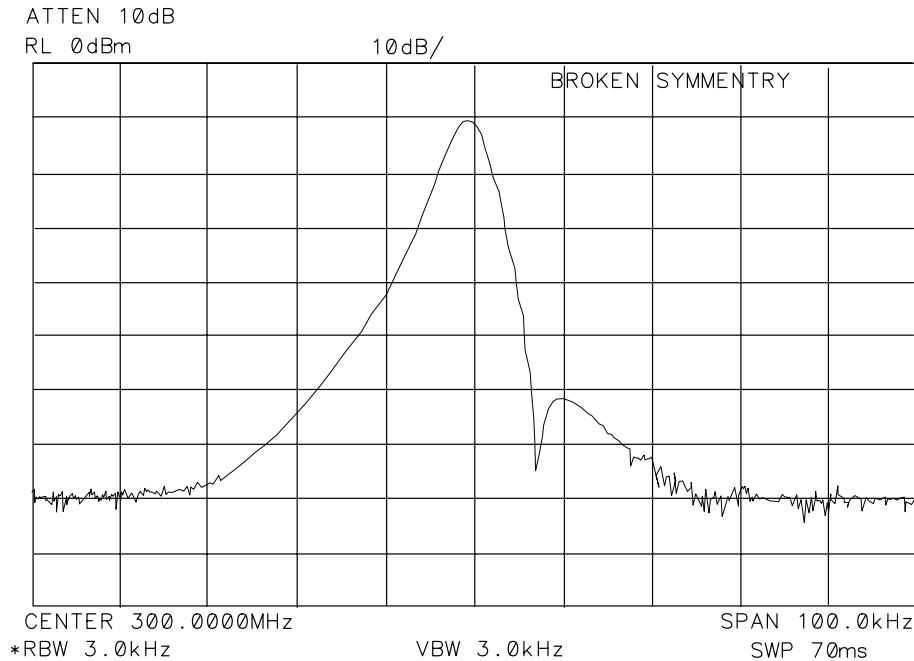

SK184

Step Gains

Refer to function blocks B, H, and I of A5 IF filter schematic diagram (sheets 1 of 3 and 2 of 3) in the *HP 8560 E-Series Spectrum Analyzer Component Level Information*.

1. On the spectrum analyzer, press **PRESET**, **SPAN**, **ZERO SPAN**, **FREQUENCY**, and **1 GHz**.
2. Press **CAL** and **IF ADJ OFF**.
3. Disconnect W29 (coax 7) from A5J3 and W27 (coax 3) from A5J5.
4. Inject a -5 dBm, 10.7 MHz signal into A5J3.
5. Monitor the output of A5J5 with another spectrum analyzer.
6. Simultaneously decrease the signal generator output and spectrum analyzer reference level in 10 dB steps down to a -50 dBm reference level.
7. At each step, the signal displayed on the other spectrum analyzer should be close to $+10$ dBm. (More subtle IF gain problems might require smaller signal generator and reference level steps.)
8. Reconnect W29 to A5J3 and W27 (coax 3) to A5J5.

Cal Oscillator Assembly (P/O A4)

The cal oscillator on the A4 assembly supplies the stimulus signal for automatic IF adjustments. Normally, the oscillator operates only during retrace (for a few milliseconds) to adjust part of the IF. (All IF parameters are to be readjusted about every 5 minutes.) With continuous IF adjust ON, a group of IF parameters are adjusted during each retrace period (non-disruptive). If continuous IF adjust is OFF, the most recent IF calibration data is used.

The IF parameters adjusted include step gains, log amplifier gain and offset, bandwidth centering, 3 dB bandwidth, bandwidth amplitude, and crystal-filter symmetry.

The cal oscillator provides three types of output signals (all -35 dBm):

- 10.7 MHz
- 9.9 to 11.5 MHz in 100 kHz steps
- Frequency sweeps from 20 kHz to 2 kHz centered at 10.7 MHz (lasting 5 to 60 ms respectively)

The signals perform the following functions:

- Adjust gains, log amps, and video slopes and offsets.
- Adjust 3 dB bandwidth and center frequencies of LC resolution bandwidth filters (30 kHz through 1 MHz).
- Adjust 3 dB bandwidth, symmetry, and gain of the crystal resolution bandwidth filters (300 Hz through 10 kHz).

The cal oscillator uses a phase-locked loop (PLL). The oscillator (function block X) is locked to the instrument 10 MHz reference. The reference divider (function block U) divides the reference and delivers a 100 kHz TTL signal to the phase detector (function block V). The divide-by-N circuitry (function block Y) divides the oscillator output of 9.9 MHz to 11.5 MHz (by 99 to 115) resulting in a 100 kHz output to the phase detector. When the cal-oscillator PLL is locked, narrow positive and negative of equal width pulses occur at the phase detector output. Since the phase detector drives a low-input impedance at the loop integrator, observe the positive pulses at A4CR808 anode and negative pulses at A4CR809 cathode.

The loop integrator acts as a low-pass filter that filters the pulses and inverts the result. If the anode of A4CR808 is more positive (with respect to ground) than the cathode of A4CR809 is negative, the loop integrator output should saturate to approximately -13 V. Conversely, if the anode of A4CR808 is less positive than the cathode of A4CR809 is negative, the integrator should saturate to a positive voltage.

NOTE

If error messages ERR 581 AMPL or ERR 582 AMPL appears, refer to error message ERR 582 AMPL in Chapter 6 and perform the procedure provided.

1. The oscillator output frequency should exceed 11.5 MHz if the CAL OSC TUNE line, A4U804 pin 14, exceeds +9 V. The oscillator frequency should be less than 9.9 MHz if CAL OSC TUNE is less than -9 V. The oscillator only operates when CALOSC_OFF is low (0 V).
2. If the cal oscillator remains locked (no error code ERR 499 displayed) but does not have the correct output level, troubleshoot the output leveling circuitry (function blocks AA, AB, and AC) or output attenuator (function block AD).

Cal Oscillator Unlock at Beginning of IF Adjust

1. Press **LINE** to turn the spectrum analyzer off and then on. The words IF ADJUST STATUS appear on the display 10 seconds after the instrument is turned on (assuming the rest of the instrument is working correctly). Immediately observe the lower right corner of the display for error messages. If the message ERR499 CAL UNLK appears (before errors ERR 561, ERR 562 and ERR 565), the cal oscillator is unable to phase-lock. Expect to see the ERR 499 message for only about 1 second.
2. If the spectrum analyzer registers an unlocked cal oscillator, continue with step 3 to verify the presence of externally supplied signals.
3. Check A4U811 pin 9 for a 100 kHz TTL-level square wave verifying operation of A4U811, A4Q802, and the 10 MHz input signal from A4J7.
4. Check the +15 VF, +5 VF and -15 V power supplies, and +10 V reference on the A4 assembly.
5. Check that A4U807 pin 5 (CALOSC_OFF) becomes TTL low (0 V) at the start of a FULL IF ADJ (press **CAL** and **FULL IF ADJ**). The phase modulation output at A4U804 pin 8 should also remain at 0 volts. If these checks are correct, troubleshoot blocks V, W, X, and Y. See [Figure 8-21 on page 463](#), A4 Log Amplifier/Cal Oscillator Block Diagram (2 of 2).

Inadequate CAL OSC AMPTD Range

Refer to function block AC of A4 Log Amplifier Schematic Diagram in the *HP 8560 E-Series Spectrum Analyzer Component Level Information*.

1. If A4R826, CAL OSC AMPTD, has inadequate range to perform the IF Amplitude Adjustment, press **CAL**.
2. Rotate A4R826 fully clockwise and disconnect W52 (coax 9) from A5J4.
3. Connect A5J4 to the input of a second spectrum analyzer.
4. Set the other spectrum analyzer controls as follows:
 - Center frequency 10.7 MHz
 - Reference level -30 dBm
5. Observe the spectrum analyzer display while pressing **FULL IF ADJ**. The signal level should be greater than -34.55 dBm. If the signal level is incorrect, continue with step 7.
6. Rotate A4R826 fully counterclockwise. The signal should be less than -36.25 dBm. If the signal level is correct at both settings, troubleshoot the A5 IF assembly. If the signal level is incorrect, continue with step 7.
7. Troubleshoot the ALC loop on this assembly using the following steps:
 - a. Connect a positive DVM probe to A4J9 pin 4.
 - b. On the spectrum analyzer, press **CAL**.
 - c. Press **FULL IF ADJ**. Observe the DVM reading between the displayed messages **IF ADJUST STATUS: 300 kHz RBW** and **IF ADJUST STATUS: 3 kHz RBW**. During this time period, the voltage should be within a 2 to 10 Vdc range.
 - d. Observe the DVM reading while **IF ADJUST STATUS: AMPLITUDE** is displayed. The reading should be within the 2 to 10 Vdc range.
 - e. If the DVM reading is outside the range in step c but inside the range in step d, suspect a reactive component in the filter.
8. If the ALC loop is working correctly (A4J9 pin 4 within the test tolerances given), then either the output attenuator is defective, or A4U810 pin 6 (in ALC loop integrator) is outside of its +3 to +6 Vdc range.
9. Reconnect W52 (coax 9) to A5J4.

300 Hz to 3 kHz Resolution Bandwidth Out of Specification

1. If the 3 dB bandwidth of one of these filters is incorrect, suspect a failure of one of the five available sweeps from the sweep generator in the cal oscillator (function block Z). These sweeps are generated by changing the switch settings of A4U803 which routes signals through A4U802 and A4U804.
2. Disconnect W52 (coax 9) from A4J8.
3. Connect the source connection of a 3 dB power splitter (Minicircuits Model: ZSC J-2-1) to A4J8. Connect one output of the power splitter to the input of an HP 8566A/B spectrum analyzer. Connect the other output of the power splitter to cable W52 (coax 9).

NOTE

If a 3 dB power splitter is not available, an SMB tee and an active probe may be substituted. Connect the active probe between the tee and the other spectrum analyzer. The absolute power levels are approximately 3 dB higher than those stated below, due to the elimination of the 3 dB power splitter.

4. Press **INSTR PRESET** on the HP 8566A/B and set the controls as follows:

| | |
|----------------------------|----------|
| Center frequency | 10.8 MHz |
| Span | 0 Hz |
| Reference level | -43 dBm |
| Resolution bandwidth | 100 kHz |
| Video bandwidth | 10 kHz |
| Sweep time | 50 ms |
| Scale | 1 dB/DIV |
| Sweep | Single |

5. On the spectrum analyzer, press **PRESET** and **CAL**.
6. Press **FULL IF ADJ**. When the display reads **ADJUSTING IF:** 10 kHz RBW, press **SINGLE** on the HP 8566A/B.
7. The HP 8566A/B screen illustrates frequency versus time of the cal oscillator output sweeps. See [Figure 8-16 on page 455](#). The slope of the HP 8566A/B 100 kHz resolution bandwidth is used to detect frequency changes. Sweeps that vary (greater than 30%) from the normal levels, trigger error code **ERR 581** or **ERR 582**.

8. Press **FULL IF ADJ**. When the display reads **ADJUSTING IF: 3 kHz**, press **SINGLE** on the HP 8566A/B.
9. [Figure 8-17 on page 456](#) illustrates normal operation. Severe failures (slope error greater than 30 percent) and subtle 3 kHz resolution bandwidth errors (less than 30 percent) indicate a problem with A4U802, A4U803, A4U804, or A4U106.
10. Severe failure of the bandwidth accompanied by subtle errors in the output signal indicate an A5 failure.
11. Set the HP 8566A/B controls as follows:

| | |
|----------------------------|------------|
| Center frequency | 10.710 MHz |
| Resolution bandwidth | 10 kHz |
| Video bandwidth | 1 kHz |
| Sweep time | 200 ms |
12. On the spectrum analyzer, press **FULL IF ADJ**. When the message **IF ADJUST STATUS: 1 kHz RBW** appears, press **SINGLE** on the HP 8566A/B.
13. [Figure 8-18 on page 457](#) illustrates normal operation. Severe failures (slope error greater than 30%) and subtle 3 kHz resolution bandwidth errors (less than 30%) indicate a problem with A4U802, U803, U804, or U106.
14. On the spectrum analyzer, press **FULL IF ADJ**. When the message **IF ADJUST STATUS: 300 Hz RBW** appears, press **SINGLE** on the HP 8566A/B.
15. [Figure 8-19 on page 458](#) illustrates normal operation. Severe failures (slope error >30%) and 3 kHz resolution bandwidth errors (less than 30%) indicate a problem with A4U802, U803, U804, or U106.
16. Reconnect W52 (white) to A4J8.

Figure 8-16 **Output Waveform, 10 kHz Resolution Bandwidth**

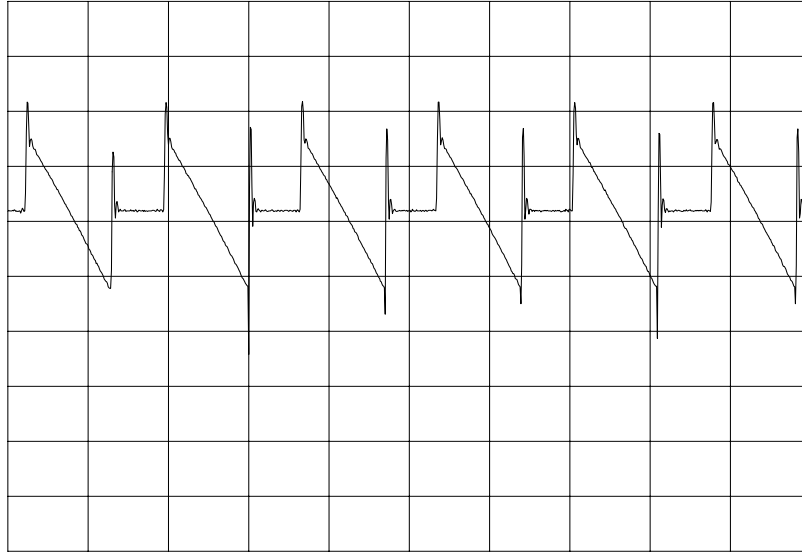

Figure 8-17 **Output Waveform, 3 kHz Resolution Bandwidth**

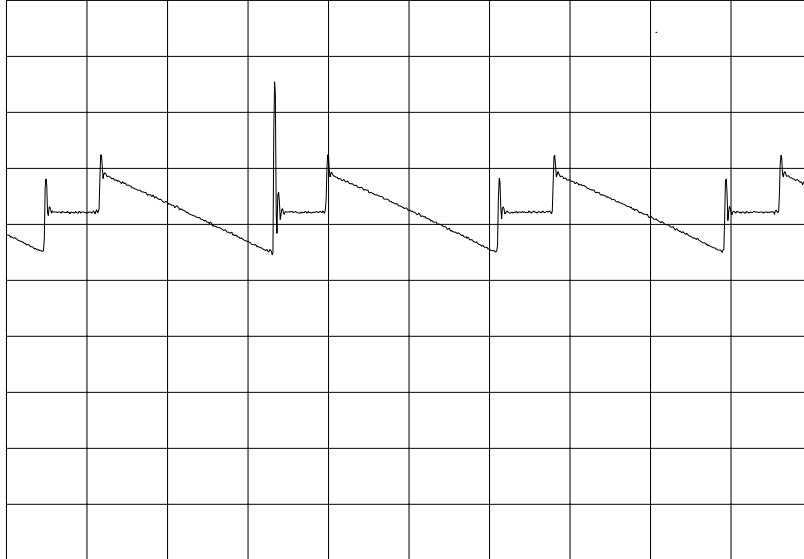

Figure 8-18 **Output Waveform, 1 kHz Resolution Bandwidth**

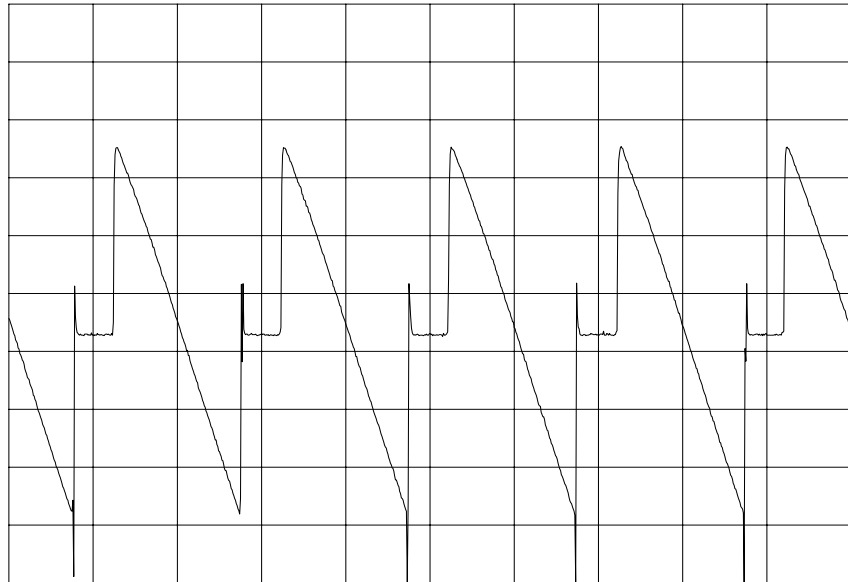

Figure 8-19 **Output Waveform, 300 Hz Resolution Bandwidth**

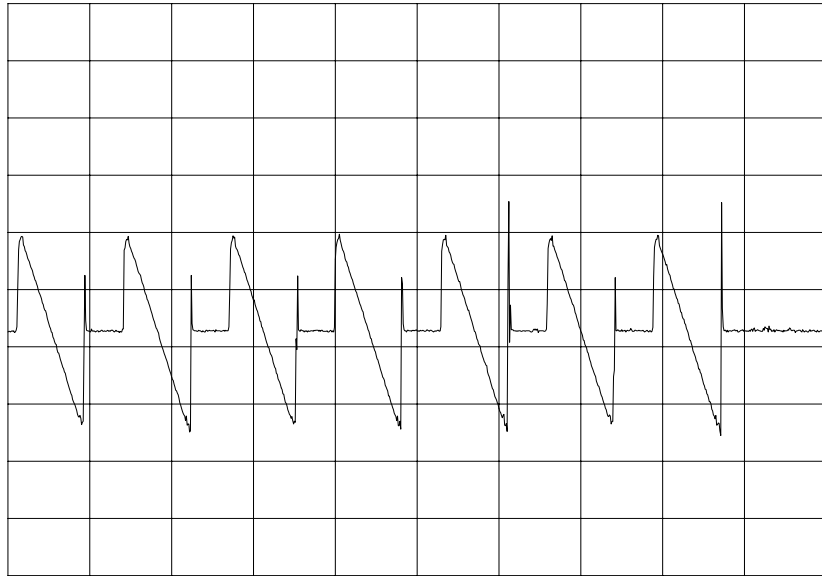
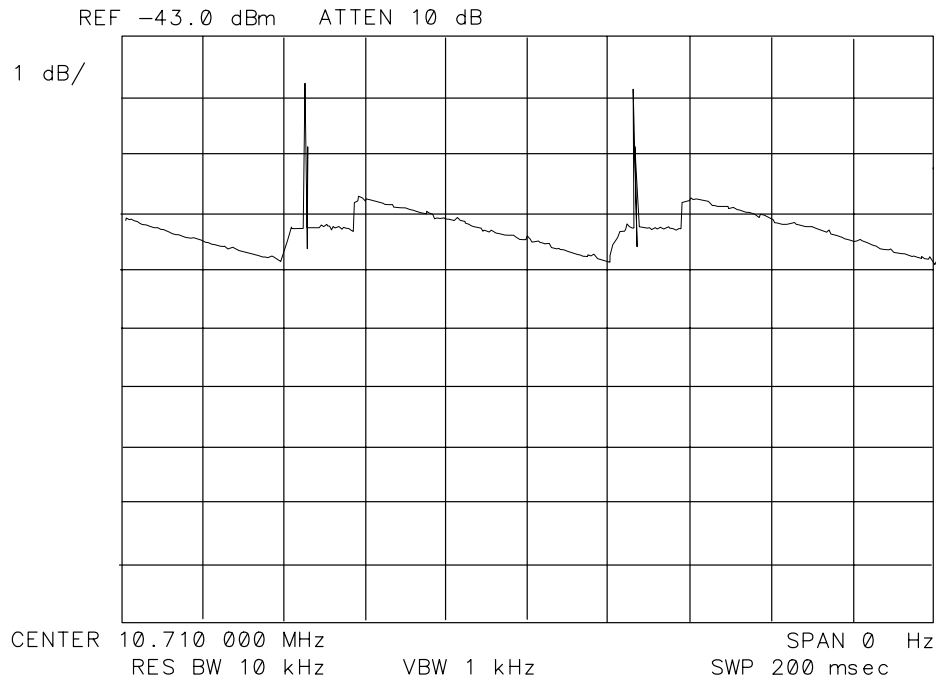

Figure 8-20 Failed Crystal Set Symptoms



SK189

Low-Pass Filter

Refer to function block AB of A4 Log Amplifier Schematic Diagram in the *HP 8560 E-Series Spectrum Analyzer Component Level Information*.

1. Connect a DVM positive probe to A4J9 pin 4.
2. On the spectrum analyzer, press **CAL**.
3. Press **FULL IF ADJUST**. Observe the DVM reading between the displayed messages **IF ADJUST STATUS: 300 kHz RBW** and **IF ADJUST STATUS: 3 kHz RBW**. During this time period, the voltage should be within a 2 to 10 Vdc range.
4. Observe the DVM reading while **IF ADJUST STATUS: AMPLITUDE** is displayed. The reading should be within the 2 to 10 Vdc range.
5. If the DVM reading is outside the range in step 3 but inside the range in step 4, suspect a reactive component in the filter.

Sweep Generator

Refer to function block Z of A4 log amplifier schematic diagram in the *HP 8560 E-Series Spectrum Analyzer Component Level Information*.

A properly operating sweep generator generates a series of negative-going parabolas. Before the sweep, switches A4U802C and A4U802D turn on, shorting A4C802 and A4C801 (the output is at 0 volts). These switches open to start the sweep. The output of A4U804A, pin 1, is 0.35 V to 10 V, depending on the sweep width selected by A4U802A and A4U803A. This voltage appears across A4R801. Capacitor A4C801 integrates the current through A4R801. The output of A4U804B is a straight, negative-going ramp. Capacitor A4C802 and resistor A4R802 integrate the output of A4U804A which starts a negative ramp (A4U804C) at the beginning of the sweep. The ramp from A4U804B is added to the current in A4R802 via A4U803B. Integrating this ramp results in the parabolic output waveform.

AM/FM Demodulation, Audio Amplifier, and Speaker

Refer to function blocks R, S, and T of A4 Log Amplifier Schematic (sheet 4 of 4) Diagram in the *HP 8560 E-Series Spectrum Analyzer Component Level Information*.

If the audio circuits are not functioning use the following procedure to isolate the problem:

1. Set an AM signal generator controls as follows:

| | |
|----------------------------|---------|
| Frequency | 100 MHz |
| Amplitude | -6 dBm |
| Modulation type | 80% AM |
| Modulation frequency | 400 Hz |

2. Set the spectrum analyzer controls as follows:

| | |
|----------------------------|---------|
| Center frequency | 100 MHz |
| Span | 0 Hz |
| Sweep time | 50 ms |
| Reference level | 0 dBm |
| Resolution bandwidth | 10 kHz |
| Amplitude scale | LINEAR |

3. Adjust the spectrum analyzer reference level and center frequency to display the 400 Hz modulation frequency eight divisions peak-to-peak.
4. On the spectrum analyzer, press **AUX CTRL**, **AM/FM DEMOD**, **AM DEMOD ON**, and set the sweep time to 5 seconds.
5. Vary the volume and listen for the variation in speaker output level. Clipping is normal at the highest volume levels.
6. If the audio is not working correctly, monitor the signal at A4U704

pin 3 with an oscilloscope. The signal should be 20 mV peak-to-peak $\pm 25\%$ (with +2.5 V of dc bias). If the signal measures outside these limits, the fault is prior to the audio amplifier (block T).

7. If the signal is correct, troubleshoot the audio amplifier and speaker.

IF Section
Cal Oscillator Assembly (P/O A4)

Figure 8-21 **A4 Log Amplifier/Cal Oscillator Block Diagram (1 of 2)**

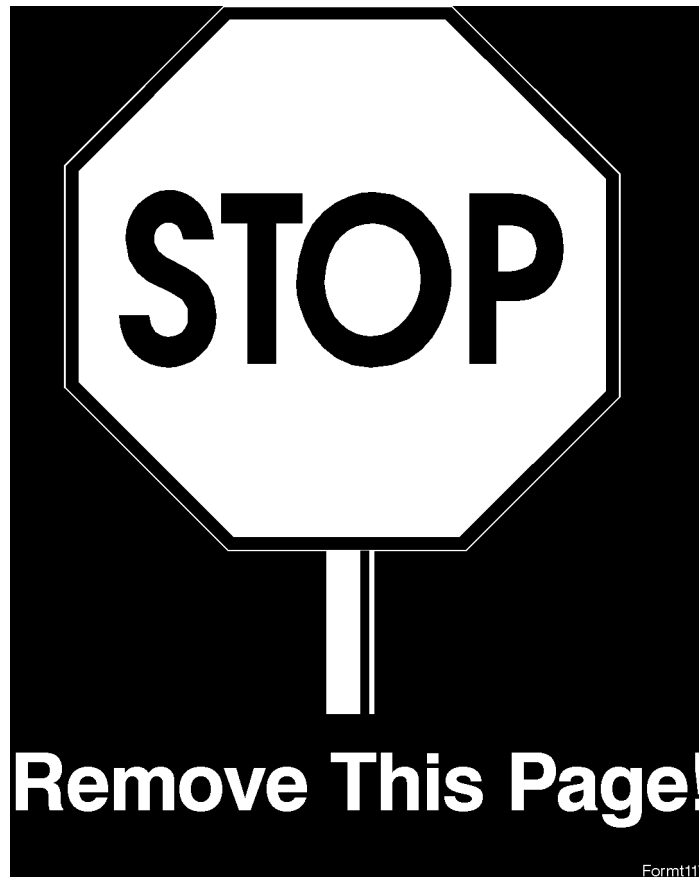

Replace with sj123e

IF Section
Cal Oscillator Assembly (P/O A4)

Figure 8-21 **A4 Log Amplifier/Cal Oscillator Block Diagram (2 of 2)**

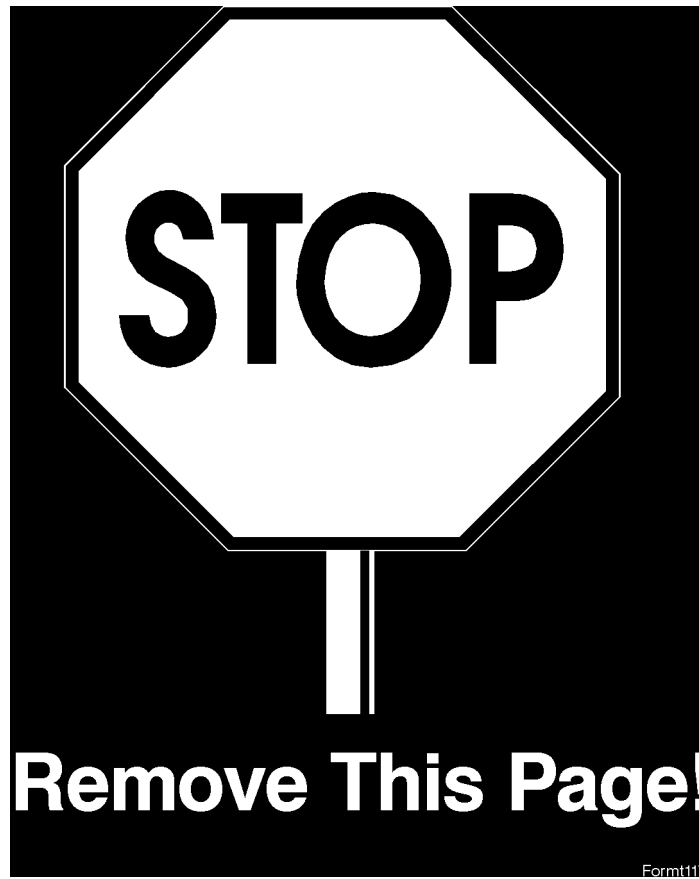

Replace with sj122e

IF Section
Cal Oscillator Assembly (P/O A4)

Figure 8-22 **A5 IF Assembly Block Diagram**

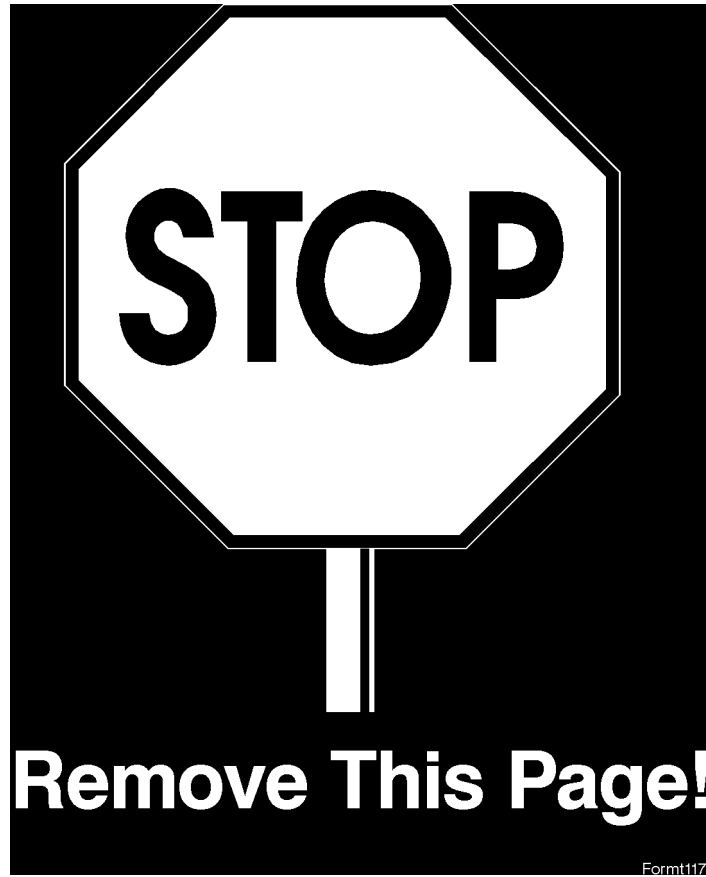

Replace with sj124e

Introduction

The controller section includes the A2 controller assembly, A19 HP-IB assembly, and BT1 battery. The presence of a display (graticule and annotation) verifies that most of the A2 controller assembly is operating properly.

| | |
|--|----------|
| Troubleshooting Using the TAM (8560E) | page 471 |
| Blank Display (8560E) | page 471 |
| Digital Signature Analysis – DSA (8560E) | page 474 |
| Display Problems (8560E) | page 475 |
| Line Generators | page 475 |
| Blanking | page 476 |
| Display Jumbled or Trace Off Screen | page 478 |
| Intensity | page 482 |
| Bad Characters or Graticule | page 483 |
| Long Lines Dimmer than Short Lines | page 483 |
| Analog Zero-Span Problems (8560E) | page 486 |
| Frequency-Count Marker Problems | page 487 |
| Frequency Counter | page 489 |
| State- and Trace-Storage Problems | page 499 |
| Keyboard Problems | page 500 |

NOTE

When measuring voltages or waveforms, make ground connections to A2TP3. The metal board-standoffs are not grounded and should not be used when taking measurements.

Troubleshooting Using the TAM (8560E)

Table 9-1 on page 471 lists assembly test connectors associated with each Manual Probe Troubleshooting test. Figure 9-1 on page 472 illustrates the location of the A2 test connectors.

Table 9-1 TAM Tests versus Test Connectors

| Connector | Manual Probe Troubleshooting Test | Measured Signal Lines |
|-----------|-----------------------------------|---------------------------|
| A2J11 | ADC/MUX Test | MS1, MS3 through MS6, MS8 |
| | DAC test | MS2, MS7, OS1 |
| A2J201 | 10 volt reference test | MS4 |
| | Switch drive test | MS8 |
| | Buffered X & Y DAC outputs | MS2, MS7 |
| | X line gen test | MS6 |
| | Y line gen test | MS1 |
| | Intensity offset output | MS3 |
| A2J202 | Revision | MS1 |
| | X, Y, & Z Output Offset | MS3, MS4, MS7 |
| | X output amplifier | MS7 |
| | Y output amplifier | MS3 |
| | Blanking test | MS8 |
| | Focus DAC test | MS2 |

Blank Display

Use the following procedure if the instrument display is blank. This procedure substitutes an HP-IB printer for the display.

1. Connect the printer to the HP 8560E and set the printer address to the value required by the TAM. This is usually 1.
2. All of the power-supply indicator LEDs along the edge of the A2 controller assembly should be lit.
3. The rear panel CRT +110 VDC ON indicator might not be lit, even if the +110 V is present.
4. Connect the TAM probe cable to A2J11.
5. Press **MODULE**, **SOFT KEY #3**, ↓, and **SOFT**

- KEY #1.** (The top soft key is #1.)
6. The yellow LED next to A2J11 should blink approximately ten times. If the LED fails to blink correctly, troubleshoot the digital section of the A2 controller assembly.
 7. Move the probe cable to A2J202. Press **SOFT KEY #1** and wait five seconds.
 8. Press **SOFT KEY #4**. The results should be sent to the printer.
 9. If a failure is indicated in any of these tests, the fault lies on the A2 controller assembly. To obtain more information:
 - a. Press the step down key, ↓ one less time than the test number. (For example, press it twice for the third test on the list.)
 - b. Press **SOFT KEY #3**, then **SOFT KEY #4**, and when the printout is complete, **SOFT KEY #6**.

Figure 9-1 A2 Test Connectors

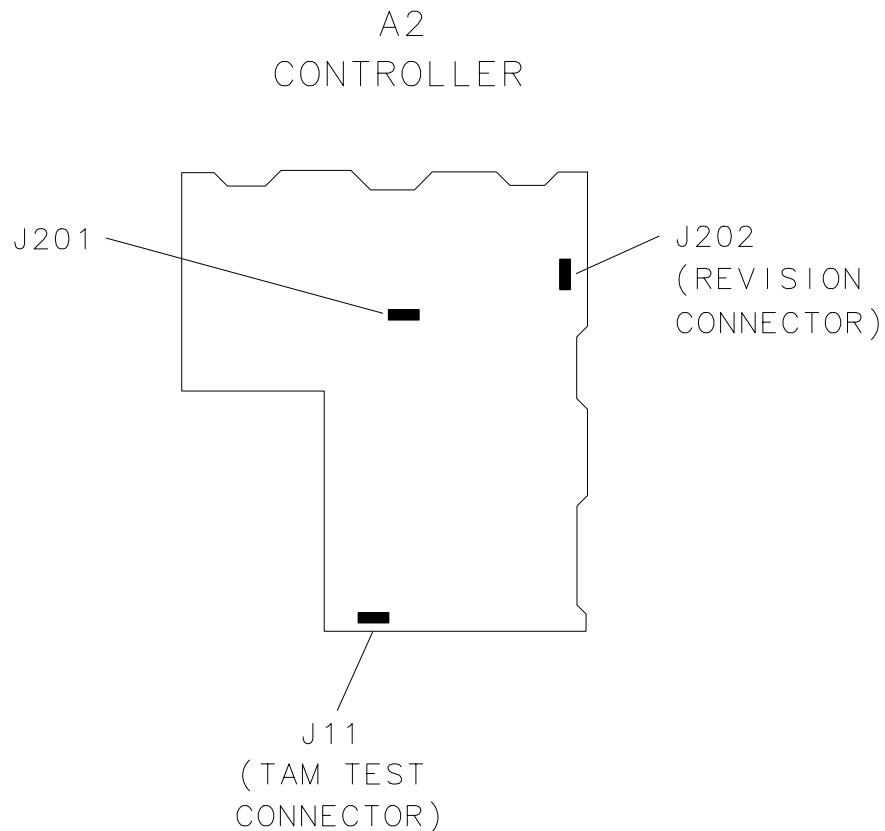

10. Move the probe cable to A2J201, press **SOFT KEY #1** and wait five seconds.
11. Press **SOFT KEY #4**. The results will be sent to the printer. Follow the procedure in step 9 to obtain more information on any of the tests.

- 12.If no failures were indicated in testing the A2 controller, move the probe cable to A17J4.
- 13.Press **SOFT KEY #1** and wait five seconds.
- 14.Press **SOFT KEY #4**. The results will be sent to the printer.
- 15.If no failure is indicated in the printout, refer to "High Voltage Supplies" in Chapter 12.

Digital Signature Analysis – DSA (8560E)

Digital signature analysis (DSA) places microprocessor, A2U1, in a simplified known state. This simplified state consists of placing a one-word instruction, MOVE QUICK, (0111 XX10 XXXX XXX0) on the data bus. The microprocessor cycles through its address range continually reading the instruction. Perform the following DSA procedure to test the operation of microprocessor, A2U1:

1. Set the HP 8560E **LINE** switch off.
2. Move the DSA jumper on J3 (located in the middle of the A2 assembly) from the DISable position to the ENable position.
3. Remove jumper A2E1. A2E1 is a 16 pin dual-in-line package located in the middle of the A2 Assembly. Set the HP 8560E **LINE** switch on.
4. Use an oscilloscope to confirm that address lines, address strobe, and chip selects are toggling at proper levels.
5. Use an oscilloscope to check the address line sequencing. The signal on each line (starting with A1 and ending with A23) should be one-half the frequency of the previous line.
6. If step 4 reveals problems, microprocessor A2U1 is probably faulty.
7. Set the HP 8560E **LINE** switch off. Replace jumper A2E1. Move the DSA jumper from connecting E5 and E6 back to connecting E6 and E7.

Display Problems (8560E)

NOTE See page [page 621](#) for information on troubleshooting 8560EC display problems.

Line Generators

Refer to function blocks D and I of A2 controller schematic diagram (sheet 1 of 4) in the *HP 8560 E-Series Component Level Information*.

The line generators convert the digital display information to an analog output suitable to drive the A17 CRT driver assembly. These circuits change the digital words into vectors, or lines, which move the beam of the CRT. The vectors are each 6 μ s long (width of the INTEGRATE pulse) followed by a 1 μ s SAMPLE pulse. When characters of text are being drawn, the vectors are 3 μ s long.

1. On the HP 8560E press **PRESET**.
2. On the HP 8560E, press **CAL**, **MORE**, and **CRT ADJ PATTERN**. If the display is blank, press the bottom softkey and then the top softkey.
3. Set an oscilloscope to the following settings:

Amplitude scale 3 V/div
Sweep time 1 ms/div
Triggering External

4. Externally trigger the oscilloscope off the signal at A2U207 pin 8 (LBRIGHT).
5. Compare the signals at the following test points with those illustrated in [Figure 9-2 on page 476](#).

X POS: A2J202 pin 14

Y POS: A2J202 pin 3

Z OUT: A2J201 pin 3

BLANKING: A2J202 pin 15

NOTE Waveforms displayed on an analog scope may show considerably more spikes. This is normal and is due to the wider displayed bandwidth.

6. Troubleshoot the circuits associated with any bad waveforms.

Figure 9-2 **Line Generator Output Waveforms**

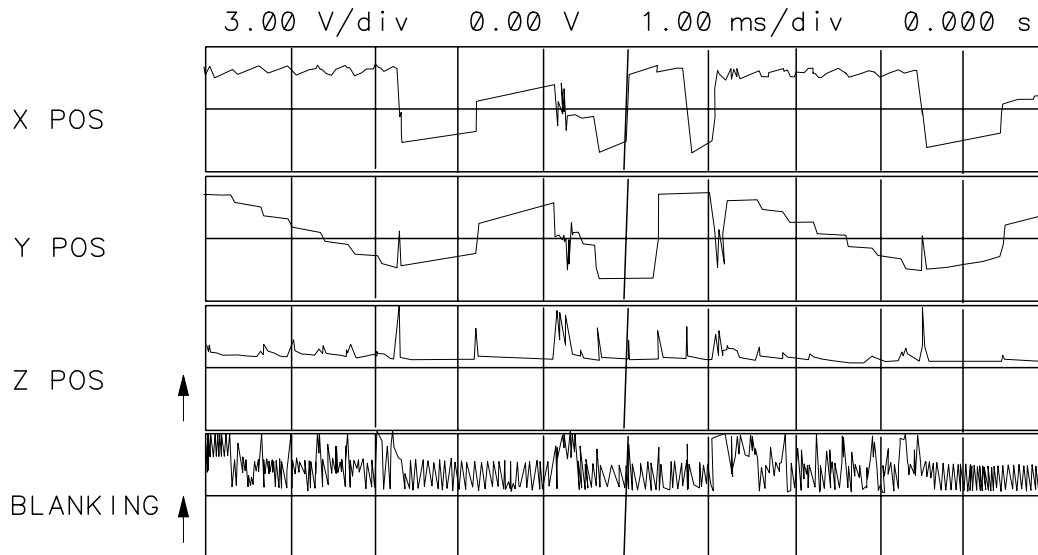

Blanking

Refer to function block J of A2 Controller Schematic Diagram (sheet 1 of 4) in the *HP 8560 E-Series Component Level Information*.

1. Using an oscilloscope, check for blanking pulses at A2J202 pin 15. A2U206 pin 6 should be at a TTL high. Blanking pulses turn the CRT beam off during the sample time of the line generators and when moving the CRT beam to a new position for drawing the next vector.

2. Set an oscilloscope to the following settings:

Amplitude scale 4 V/div
Amplitude offset +2.5 V
Sweep time 20 μ s/div
Triggering External

3. Externally trigger the oscilloscope off the signal at A2U207 pin 8 (LBRIGHT).

4. Compare the blanking-circuit input signals at the following test points with those illustrated in [Figure 9-3 on page 477](#).

BLANKING: J202 pin 15
BLANK: U214 pin 12
VECTOR: U214 pin 11
 U213 pin 13

- The waveforms in [Figure 9-3 on page 477](#) must match the timing of the vectors being drawn. To do this, U215B is used to adjust the leading edge, and U215A is used to adjust the trailing edge. The first six horizontal divisions show the line drawing mode where the VECTOR pulses are 6 μs apart. The remaining divisions shows character mode (VECTOR pulses 3 μs apart). The BLANK pulses are synchronized to the VECTOR pulses by U214B. The fourth trace shows the double pulses which delay the leading and trailing edges of the blanking pulses.
- Set the oscilloscope to the following settings to expand the first and fourth traces. This displays how the rising edges of U213-13 determine the transitions of the blanking pulses. See [Figure 9-4 on page 478](#).

Amplitude scale 4 V/div
 Amplitude offset +2.5 V
 Sweep time 2 $\mu\text{s}/\text{div}$
 Delay from trigger 96 μs
 Triggering External

Figure 9-3 **Blanking Waveforms**

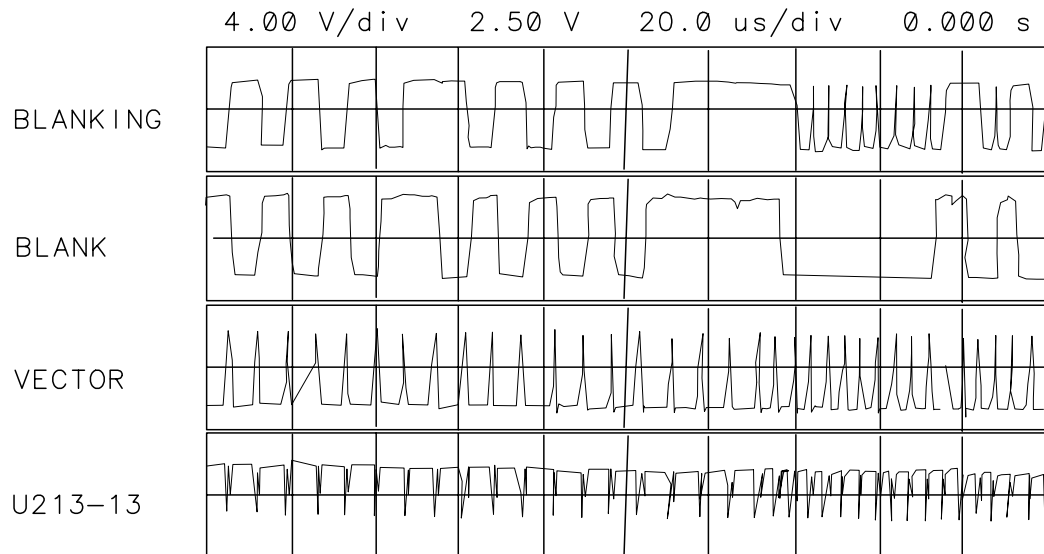
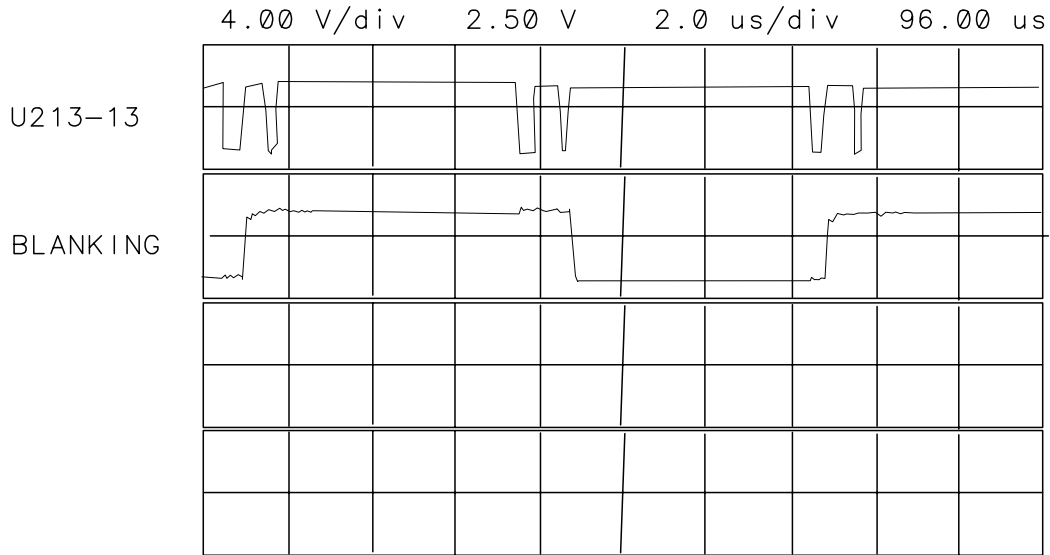

Figure 9-4 **Expanded Blanking Waveforms**



Display Jumbled or Trace Off Screen

Refer to function blocks D and I of A2 controller schematic diagram (sheet 1 of 4) in the *HP 8560 E-Series Component Level Information*.

The two line generators are identical circuits, so the following steps apply to both. The X generator is referenced below, with Y generator references in parentheses.

1. The voltage at A2U202B pin 7 should measure 10.0 V.
2. Perform steps 1 through 5 of "Line Generators" in this chapter. If the X POS and Y POS waveforms look different from those illustrated in [Figure 9-2 on page 476](#), check the waveforms at the low-pass filter input (function block E in the component-level information binder).
3. The waveform at the low-pass filter should look like X POS in [Figure 9-2 on page 476](#) but have an amplitude from 0 V to +5 V.
4. If the waveform in step 3 is incorrect, set an oscilloscope to the following settings:

Amplitude scale 10 V/div
Sweep time 20 μ s/div
Triggering External

5. Trigger the oscilloscope on the signal at U207 pin 8 (LBRIGHT).
6. Compare the line-generator input signals at the following test points with those illustrated in [Figure 9-5 on page 479](#). INTEGRATE and SAMPLE waveforms are replicas of VECTOR except for polarity and

amplitude. LCHAR is low when characters are drawn.

- INTEGRATE: Q202 collector
- SAMPLE: Q201 collector
- LCHAR: U207 pin 9
- VECTOR: U213 Pin 9

Figure 9-5 Switch Driver Waveform LCHAR

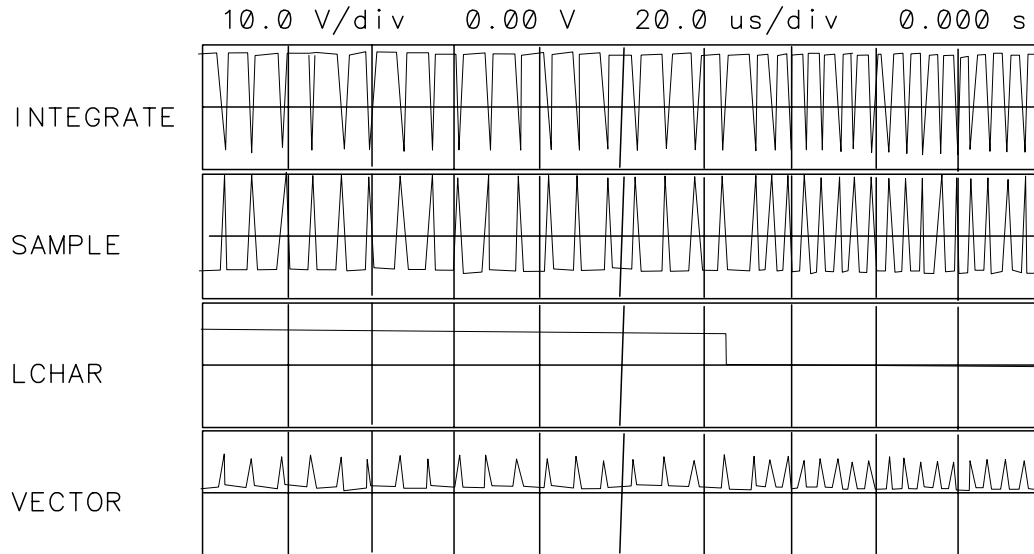

7. All of the DAC inputs should change state two or more times within a 5 ms window. If one or more DAC bits are not working correctly, this will effect the entire display, especially the diagonal lines that go from lower left to upper right. When these lines are drawn, both the X and Y DACs are stepped one count at a time. A "stuck" bit will distort the diagonal in a repetitive manner. The quicker the repetition, the less significant the "stuck" bit. Horizontal distortions apply to the X LINE GENERATOR DAC, while vertical distortions apply to the Y LINE GENERATOR DAC. The DACS have current outputs so they are not readily observable with an oscilloscope. Continue with step 8 to observe the DAC outputs.
8. To break the effect of feedback in the line generators and to observe the output of the DACs, short J201 pin 13 (J201 pin 1) to TP3 (GND) to observe U201 pin 1 and TP2 (U203 pin 1 and TP1.) Continue with step 9.
9. Set an oscilloscope to the following settings:

Amplitude scale 5 V/div
 Sweep time 1 ms/div

Coupling ac
Triggering External

10. Trigger the oscilloscope on the signal at U207 pin 8 (LBRIGHT).

11. The following waveforms should look like [Figure 9-6 on page 481](#) on the oscilloscope. The top two traces are for the X line generator and the bottom two traces for the Y line generator.

X line generator

— U201 pin 1

— TP2

Y line generator

— U203 pin 1

— TP1

12. [Figure 9-7 on page 481](#) illustrates the waveforms in step 11 expanded to show relative timing. the second and fourth traces are delayed by 5 ms from the first and third. The oscilloscope settings are changed as follows:

Sweep time 20 μ s/div

13. [Figure 9-8 on page 482](#) illustrates the waveforms of properly working line generators. Whenever there is a pulse on TP2 (or TP1), the appropriate integrator U201B (or U203B) generates a ramp (the output vector) which feeds back to U201A (U203A) and shows on its output.

Figure 9-6 Distorted X/Y Line Generator Waveforms

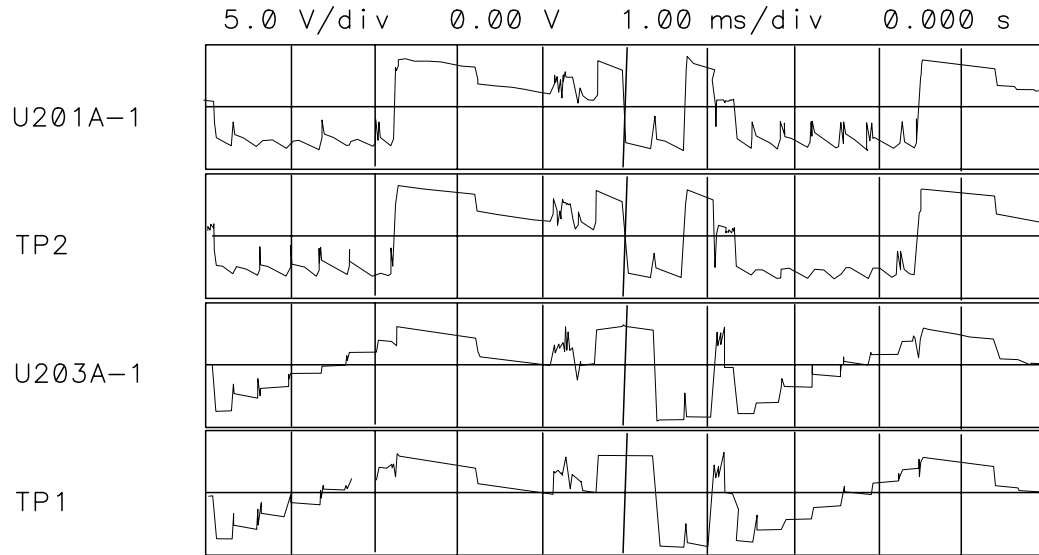

Figure 9-7 Expanded X/Y Line Generator Waveforms

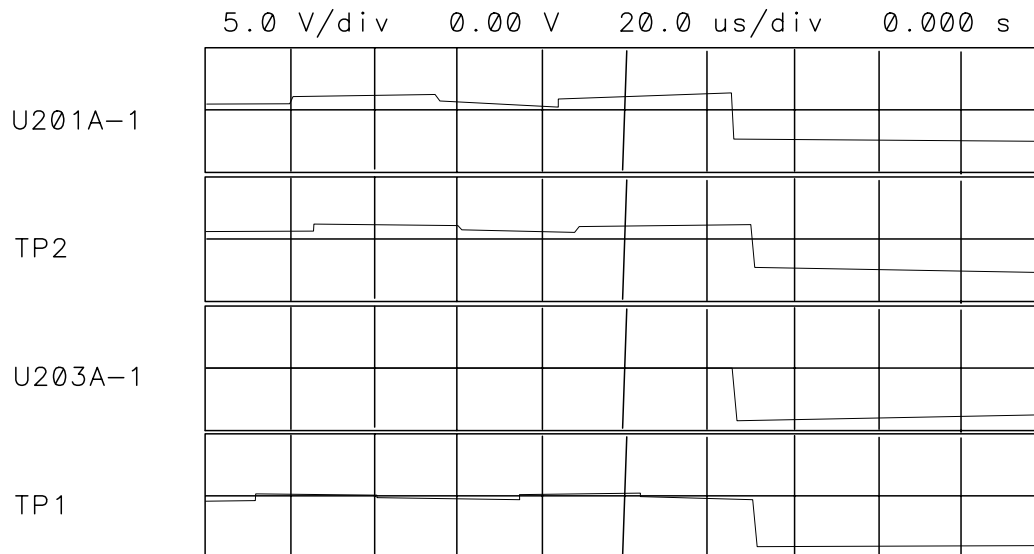
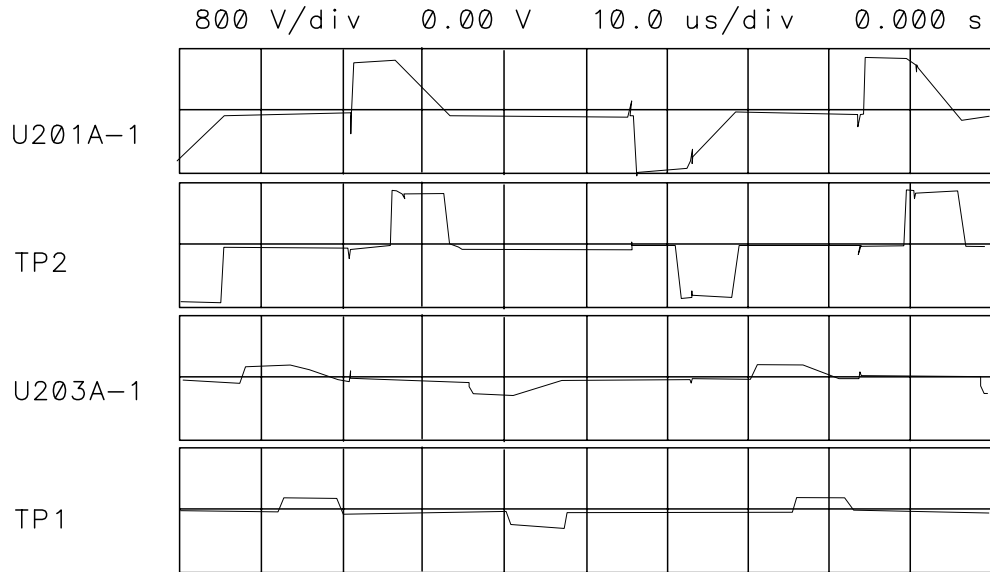

Figure 9-8 Normal X/Y Line Generator Waveforms



Intensity

1. The length of the vector being drawn can effect intensity. U210A, U210C, and U210D sum the lengths of the X and Y vectors. Refer to "Long Lines Dimmer than Short Lines" in this chapter.
2. Short A2U207 pin 6 to pin 7. If the display does not brighten, troubleshoot LBRIGHT switch, U207B. This switch intensifies trace A and active softkeys.
3. Short A2U207 pin 2 to pin 3. If the display does not brighten, troubleshoot DEF1 switch, U207A. This switch is used in analog zero-span.
4. Change the intensity (under **DISPLAY**). If the intensity does not change, troubleshoot the intensity DAC, A2U212A. (A2U212A is controlled from the front panel.) The amplitude of the waveform at U211A pin 1 should increase or decrease with intensity changes.
5. Clamp U211B limits the voltage to about 4.2 V. Short A2J201-1 to ground and set the intensity DAC to a number greater than 80. A major portion of the waveform should be limited to 4.2 V.
6. If a major portion of the waveform is not limited to 4.2 V, troubleshoot the maximum brightness clamp, A2U211C.

Bad Characters or Graticule

If the displayed characters are bad but the graticule is correct (or if the symptoms are reversed), troubleshoot the X- and Y- generator switches A2U207D and A2U207C. Check that the switch driver signal LCHAR is working properly. Refer to "Display Jumbled or Trace Off Screen" in this chapter.

Long Lines Dimmer than Short Lines

Refer to function block M of A2 controller schematic diagram (sheet 1 of 4) in the *HP 8560 E-Series Component Level Information*.

The Z output function block contains the absolute value circuits which determine the intensity of vectors drawn on the display. The vector length is approximated by the sum of the X length and Y length. The voltage corresponding to the X length, ΔX , is converted to current by R274. If the voltage is negative, it is amplified by 2 in A2U210C, converted to current by A2R246, and added to the current from A2R274. This effectively turns both negative and positive voltages into positive currents, hence absolute value.

1. Short A2J201 pin 13 to ground (A2TP3).
2. Connect channel A of an oscilloscope to A2J201 pin 2. Connect channel B to A2U210D-14.
3. Set an oscilloscope to the following settings:

| | |
|-----------------------|----------|
| Amplitude scale | 10 V/div |
| Sweep time | 1 ms/div |
| Triggering | External |
4. Externally trigger the oscilloscope off the signal at A2U207 pin 8 (LBRIGHT).
5. The waveforms should look like those illustrated in [Figure 9-9 on page 484](#). If the waveform at J201 pin 2 is bad, troubleshoot the X line generator (function block D of the A2 controller schematic, sheet 1 of 4).
6. If the waveform at U210D pin 14 is bad, troubleshoot the Z output circuit (function block M of A2 controller schematic, sheet 1 of 4).
7. Remove the short from J201 pin 13 to ground. Short A2J201 pin 1 to ground.

Figure 9-9 Delta X Waveform

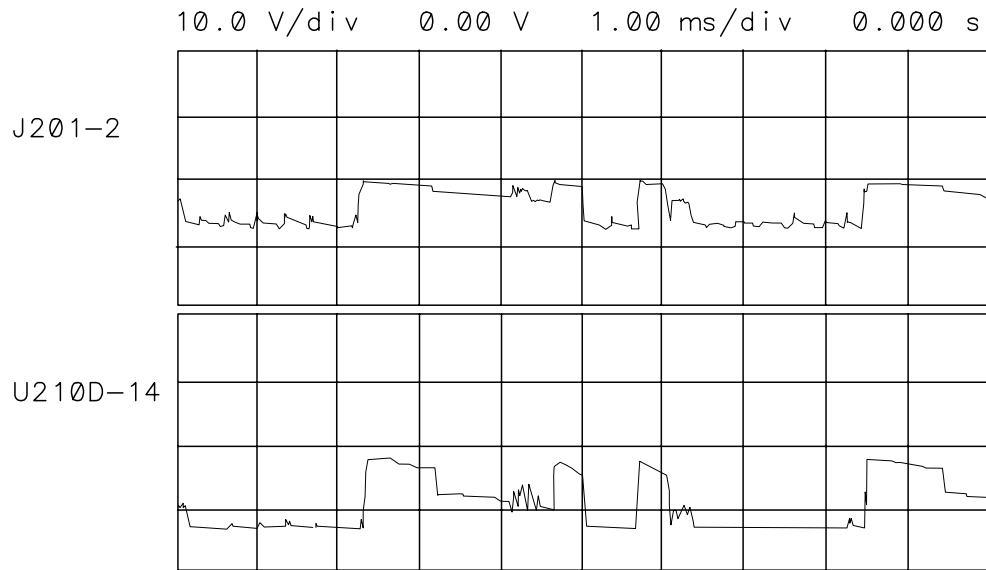

8. Move the oscilloscope channel A probe to J201 pin 14.
9. The waveforms should look like those illustrated in [Figure 9-10 on page 485](#). If the waveform at J201 pin 14 is bad, troubleshoot the Y line generator (function block I of A2 controller schematic, sheet 1 of 4).
10. If the waveform at U210D pin 14 is bad, troubleshoot the Z output circuit (function block M of A2 controller schematic, sheet 1 of 4).
11. Remove the jumpers.

Figure 9-10 **Delta Y Waveform**

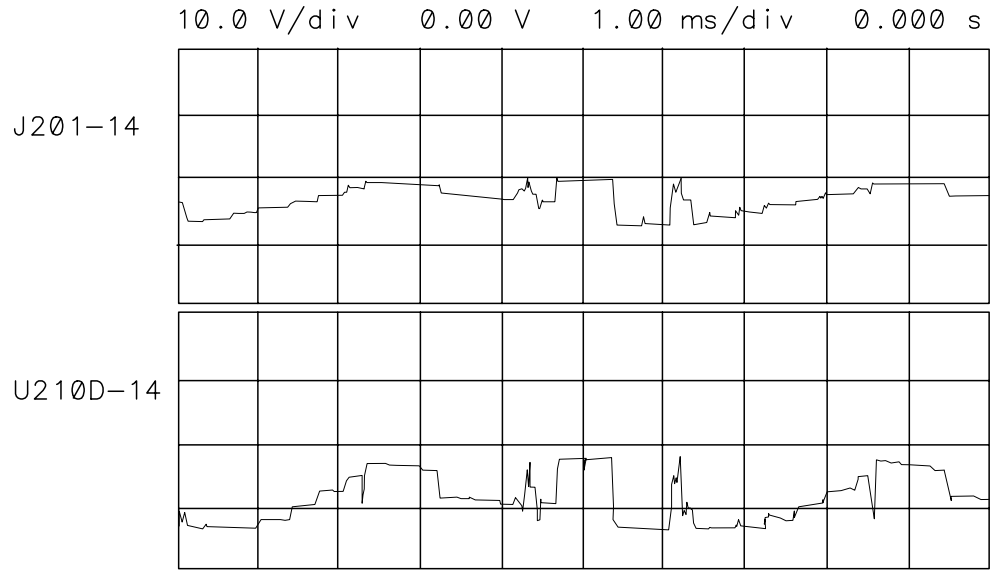

Analog Zero-Span Problems (8560E only)

1. On the HP 8560E, press PRESET, SPAN, ZERO SPAN, SWEEP, 1, ms, CAL, MORE, and CRT ADJ PATTERN.
2. Set an oscilloscope to the following settings:
Amplitude scale 10 V/div
Sweep time 1 ms/div
Triggering External
3. Externally trigger the oscilloscope off the signal at A2U207 pin 8 (LBRIGHT).
4. The display should be similar to [Figure 9-11 on page 486](#) except that the untriggered trace should show at the left edge of the screen. In these settings, DEF1 causes switching between the line generators and the analog inputs (sweep and video). DEF1 remains high when the CRT adjust pattern is on. Refer to function block M of the A2 controller schematic, 1 of 4.
5. The sweep input from J1-41 should go from 0 V to +10 V; the video In signal should go from about 0 V to 1 V from the bottom to the top of the screen. Apply a dc voltage to A2J4, Video In, to test the circuit.
6. In [Figure 9-11 on page 486](#), there is no synchronization between DEF1 and the video patterns X POS and Y POS when DEF1 is TTL high. The Y POS level when DEF1 is low is the Video In level.

Figure 9-11 DEF1 Synchronization

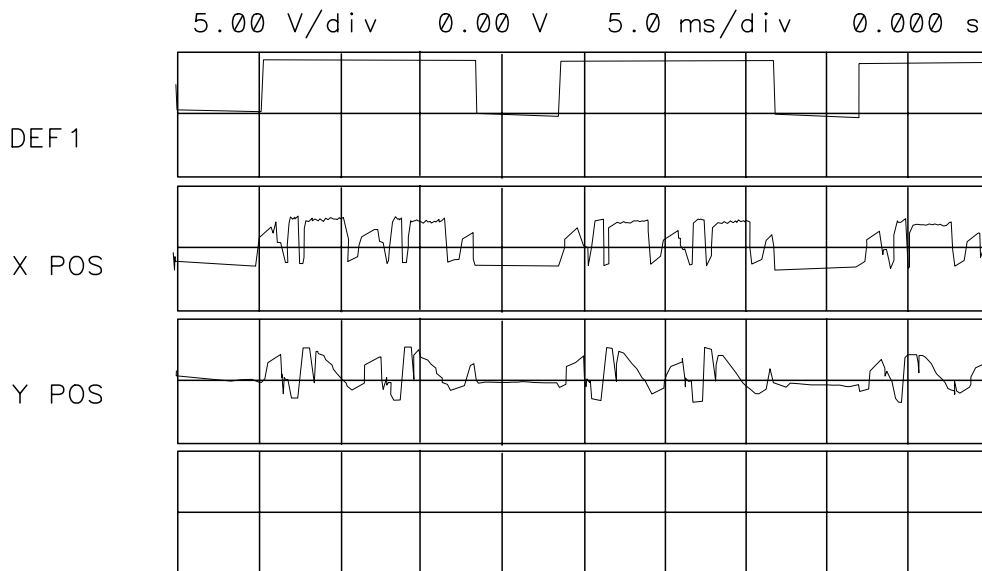

Frequency-Count Marker Problems (8560EC)

The **FREQ COUNT** function works by dividing the 10.7 MHz IF signal by two (prescaling) and counting the divided-down signal using the frequency counter on the A2 controller assembly . The prescaler is on the A4 Log amplifier/cal oscillator assembly . Perform the following steps to determine whether the problem is on the A4 log amplifier/cal oscillator or the A2 controller assembly:

1. Disconnect W53 from A2J13.
2. Connect the output of a synthesized source, such as an HP 3335A, to A2J13.
3. Set the synthesized source to the following settings:
Amplitude +10 dBm
Frequency 5.35 MHz
4. Set the spectrum analyzer to the following settings:
Center frequency 300 MHz
Span 1 MHz
5. On the spectrum analyzer, press **FREQ COUNT**. The frequency counter actually reads one half the frequency of the 10.7 MHz IF. If the CNT frequency display reads all asterisks, the frequency counter is probably at fault.
6. If a valid frequency is displayed, troubleshoot the prescaler on the A4 log amplifier/cal oscillator assembly.
7. Reconnect W53 to A2J13.

Frequency-Count Marker Problems (8560E)

The **FREQ COUNT** function works by dividing the 10.7 MHz IF signal by two (prescaling) and counting the divided-down signal using the frequency counter on the A2 controller assembly (block Z of the A2 schematic diagram). The prescaler is on the A4 Log amplifier/cal oscillator assembly (block Q of the A4 schematic diagram). Perform the following steps to determine whether the problem is on the A4 log amplifier/cal oscillator or A2 controller assembly:

1. Disconnect W53 from A2J7.
2. Connect the output of a synthesized source, such as an HP 3335A, to A2J7.
3. Set the synthesized source to the following settings:
 - Amplitude +10 dBm
 - Frequency 5.35 MHz
4. Set the spectrum analyzer to the following settings:
 - Center frequency 300 MHz
 - Span 1 MHz
5. On the spectrum analyzer, press **FREQ COUNT**. The frequency counter actually reads one half the frequency of the 10.7 MHz IF. If the CNT frequency display reads all asterisks, the frequency counter is probably at fault.
6. If a valid frequency is displayed, troubleshoot the prescaler on the A4 log amplifier/cal oscillator assembly.
7. Reconnect W53 to A2J7.

Frequency Counter (8560EC)

The frequency counter counts the frequency of the last IF and provides accurate timing signals for digital zero-spans. The circuit also provides timing signals to the ADC (analog to digital converter) on the A3 interface assembly. The nominal input frequency is 5.35 MHz (10.7 MHz divided by 2). The 10 MHz reference from the A15 RF assembly provides the frequency reference in the frequency count mode. The frequency reference in digitized zero spans (sweep times ≥ 30 ms) is the 4 MHz HPIB_CLK, selected by a clock select multiplexer in U35.

The 10 MHz reference from the A15 RF assembly is first filtered and passed through a comparator to generate a TTL, 50 percent duty cycle signal. C128, L16, and R91 provide a bandpass filter centered at 10 MHz. The output of comparator U33B is the actual reference used for the Frequency Counter. An additional stage of filtering is performed on this signal to provide a 10 MHz signal for the A17 LCD Driver assembly.

In the frequency count mode, the 10 MHz reference is prescaled by 5 to generate a 2 MHz timebase. This timebase feeds through the clock select multiplexer in U35 to the CLK2 input of programmable timer U15. The output (OUT2) of programmable timer U15 is the gating signal (HBKT_PULSE); it performs the frequency count. The gating time interval is a function of the counter resolution which may be set between 10 Hz and 1 MHz. [Table 9-2 on page 490](#) lists the gate time for each setting of COUNTER RES. The gate time is the period during which HBKT_PULSE (pin 20 of U15) is low.

The FREQ COUNT input, A2J13, is gated by HBKT_PULSE. The gated signal clocks divide-by-16 counters within U35. These counters are cascaded to form a divide-by-256 counter. The MSB of this counter, CD7, clocks the CLK0 input of U15. The frequency of CD7 is a function of COUNTER RES as shown in [Table 9-2 on page 490](#). If timer U15 overflows, OUT0 will be set, generating CNTOVFLIRQ, which will interrupt the CPU.

If IRQAK2 is high, HBKT_PULSE will generate FREQCNTLIRQ. Upon receiving the FREQCNTLIRQ interrupt, the CPU latches the CD0 to CD7 onto the BID bus by setting LCDRD (low counter data read) low and reading the counter data from the BID bus. The CPU will also read the data from the timer, U15, by setting L8254CS and LCNTLRD low, placing the timer data on the BID bus. The CPU then resets IRQAK2 low.

Table 9-2

Gate Times

| Counter Res | Gate Time* (U15 pin 20 low state) | A2TP16 | A2TP15 |
|---|---|--------|----------|
| 10 Hz | 200 ms | 2 MHz | 4.18 kHz |
| 100 Hz | 20 ms | 2 MHz | 418 Hz |
| 1 kHz | 2 ms | 2 MHz | 41.8 Hz |
| 10 kHz | 2 ms | 2 MHz | 41.8 Hz |
| 100 kHz | 2 ms | 2 MHz | 41.8 Hz |
| 1 MHz | 2 ms | 2 MHz | 41.8 Hz |
| * U15 pin 10 = (FREQ COUNT input × Gate Time)/256 | | | |

1. Disconnect W22 from A2J9.
2. If a 10 MHz, TTL-level signal is not present at the end of W22, continue with step 3. If a 10 MHz signal is present at W22, proceed as follows:
 - a. Reconnect W22 to A2J9.
 - b. Set the spectrum analyzer to the following settings:

| | |
|------------------|-----------|
| Span | Zero Span |
| Sweep time | 20 ms |
 - c. Monitor the signal at A2J2 pin 21. This is an output of the frequency counter, HBUCKET PULSE.
 - d. If HBUCKET PULSE is stuck high, troubleshoot the frequency counter.
3. Check for a 10 MHz signal at A15J302. If the signal is not present at A15J302, the A15 RF assembly is probably defective.

Frequency Counter (8560)

See function block Z of A2 schematic diagram (sheet 4 of 4) in the *HP 8560 E-Series Spectrum Analyzer Component Level Information*.

The frequency counter counts the frequency of the last IF and provides accurate timing signals for digital zero-spans. The circuit also provides timing signals to the A3 interface assembly ADC (analog to digital converter). The nominal input frequency is 5.35 MHz (10.7 MHz divided by 2). The circuit frequency reference in the frequency count mode is the 10 MHz reference from the A15 RF assembly. The frequency reference in digitized zero spans (sweep times ≥ 30 ms) is the 4 MHz HPIB_CLK, selected by MUX U704.

In the frequency count mode, U702 prescales the 10 MHz reference by 5 to generate a 2 MHz timebase. This timebase feeds through MUX U704 to programmable-timer U700 CLK2 input. Programmable-timer U700 output (OUT2) is the gating signal (HBKT_PULSE) for performing the frequency count. The gating time interval is a function of the counter resolution which may be set between 10 Hz and 1 MHz. [Table 9-2 on page 490](#) lists the gate time for each setting of COUNTER RES. The gate time is the period during which U511 pin 3 is high.

The FREQ COUNT input, A2J7, is gated in U511B by HBKT_PULSE. The gated signal clocks divide-by-16 counters U703A and U703B. These counters are cascaded to form a divide-by-256 counter. The MSB of this counter, CD7, clocks the CLK0 input of U700. The frequency of CD7 is a function of COUNTER RES as shown in [Table 9-2 on page 490](#). If timer U700 overflows, OUT0 will be set and U701B clocked, generating CNTOVFLIRQ, which will interrupt the CPU.

If IRQAK2 is high, HBKT_PULSE will clock U701A, generating FREQCNTLIRQ. Upon receiving the FREQCNTLIRQ interrupt, the CPU latches the CD0 to CD7 onto the BID bus by setting LCDRD (low counter data read) low and reading the counter data from the BID bus. The CPU will also read the data from the timer, U700, by setting L8254CS and LCNTLRD low, placing the timer data on the BID bus. The CPU resets U701A by setting IRQAK2 low via the BID bus and latch U506.

Table 9-3

Gate Times

| Counter Res | Gate Time* (U511 pin 3 high state) | A2TP16 | A2TP15 |
|---|--|--------|----------|
| 10 Hz | 200 ms | 2 MHz | 4.18 kHz |
| 100 Hz | 20 ms | 2 MHz | 418 Hz |
| 1 kHz | 2 ms | 2 MHz | 41.8 Hz |
| 10 kHz | 2 ms | 2 MHz | 41.8 Hz |
| 100 kHz | 2 ms | 2 MHz | 41.8 Hz |
| 1 MHz | 2 ms | 2 MHz | 41.8 Hz |
| * TP15 = (FREQ COUNT input × Gate Time)/256 | | | |

1. Disconnect W22 from A2J8.
2. If a 10 MHz, TTL-level signal is not present at the end of W22, continue with step 3. If a 10 MHz signal is present at W22, proceed as follows:
 - a. Reconnect W22 to A2J8.
 - b. Set the spectrum analyzer to the following settings:

| | |
|------------------|-----------|
| Span | Zero Span |
| Sweep time | 20 ms |
 - c. Monitor the signal at A2J2 pin 21. This is an output of the frequency counter, HBUCKET PULSE.
 - d. If HBUCKET PULSE is stuck high, troubleshoot the frequency counter.
3. Check for a 10 MHz signal at A15J302. If the signal is not present at A15J302, the A15 RF assembly is probably defective.

Video Input Scaling Amplifiers and Limiter (8560EC)

The video input scaling amplifiers help provide scaling (10 dB/div, 5 dB/div, 2 dB/div, or 1 dB/div) and buffer the flash video output. When the GAINX2 control line is low, switch U44D is open and switch U44C is closed. Thus, the scaled video at TP26 virtually follows the video input (0 - 1 V). When the GAINX2 control line is high, switch U44C is open and switch U44D is closed. Amplifier U43 then provides a gain of $2(V_{in}) - 1$ V. Voltage clamp CR4 prevents the scaled video input to amplifier U45 from going more negative than -0.35 V or more positive than $+1.25$ V.

NOTE

When measuring voltages or waveforms on the Fast ADC section of the A2 controller assembly, connect the ground (or common) lead to the ground-plane trace associated with the shield. This digital ground plane is totally isolated from the chassis.

1. Press **PRESET** on the HP 8560 EC-series spectrum analyzer and set the controls as follows:

| | |
|------------------------|-----------|
| Center frequency | 300 MHz |
| Span | 0 Hz |
| Reference level | -10 dBm |
| Log/division | 10 dB/DIV |
| Sweep time | 20 ms |
2. Connect the CAL OUTPUT to the INPUT 50 Ω connector.
3. Adjust the spectrum analyzer reference level to place the signal at the top graticule line on the LCD display.
4. Measure the dc level at pin 3 of U10. If the voltage measured is not $+1.0 \pm 0.15$ V, troubleshoot the A3 interface assembly.
5. Measure the dc level at pin 3 of U17. The level should be approximately the same as the level measured at pin 3 of U10. If not, suspect switch U9.
6. Set the spectrum analyzer scale to 5dB per division.
7. Adjust the spectrum analyzer reference level to place the signal at the top graticule line on the LCD display.
8. Measure the dc level at pin 3 of U10 and pin 3 of U17. The level should be $+1.0 \pm 0.25$ V. If the level measured at pin 3 of U17 differs from the level measured at pin 3 of U10 by more than 0.25 volts, troubleshoot U10 and associated circuitry.

9. Disconnect the CAL OUTPUT signal from the INPUT 50 Ω connector.
10. The level at pin 3 of U10 should drop to -0.35 Vdc. If the level is less (more negative) than -0.35 Vdc, replace voltage clamp D3.
11. Measure the dc level of the flash video at pin 2 of R47. The level should be near 0 Vdc with the signal at the bottom graticule line (no input to the spectrum analyzer).
12. Connect the CAL OUTPUT to the INPUT 50 Ω connector.
13. Measure the dc level of the flash video at pin 2 of R47. The level should be near $+1.7$ Vdc.

12-Bit Flash ADC (8560EC)

The flash ADC (U22) converts the analog video signal into 12-bit digital values at a fixed rate of 12 megasamples per second.

When measuring voltages or waveforms on the Fast ADC of the A2 controller assembly, connect the ground (or common) lead to the ground-plane trace associated with the shield. This digital ground plane is totally isolated from the chassis.

1. Press **PRESET** on the spectrum analyzer and set the controls as follows:

| | |
|------------------------|----------|
| Center frequency | 300 MHz |
| Span | 0 Hz |
| Reference level | -20 dBm |
| Log/division | 5 dB/DIV |
| Sweep time | 20 ms |

2. Connect the CAL OUTPUT to the INPUT 50 Ω connector.
3. Pins 2 through 13 (ADC0-ADC11) of U22 should all be high (logic 1), corresponding to an ADC digital count of 255 for the analog input of +2 volts or greater.
4. Disconnect the CAL OUTPUT signal from the INPUT 50 Ω connector.
5. Pins 2 through 13 (ADC0-ADC11) of U22 should all be low (logic 0), corresponding to an ADC digital count of zero for the analog input of 0 volts or less.

32 K-Byte Static RAM (8560EC)

The static RAM stores the ADC samples that are taken when the Fast ADC circuitry is in the "write" mode. When not in the "write" mode, the static RAM is read by the CPU to retrieve the fast ADC data. The 8-bit DFADC bus connects the outputs of latches within U35 to the data port of static RAM U21.

Reference Clock (8560EC)

The reference clock circuitry takes the 8 MHz square wave clock and triples the frequency to 24 MHz. This is accomplished through two stages of filtering of the 8 MHz signal, to extract the third harmonic. The 8 MHz signal is first passed through a high pass filter consisting of C123 and L15. The the signal passes through a bandpass filter centered at 24 MHz, consisting of C106, C08, L13, and R80. The comparator U28B generates a square wave. The signal then passes through a second stage of filtering by using the bandpass filter consisting of C89, C88, L12, and R77. Comparator U28A then regenerates the square wave. A divide-by-two flip flop in U16 divides the 24 MHz signal to create the 12 MHz signal used by the ADC.

16 MHz Harmonic Filter (8560EC)

The 16 MHz Harmonic Filter generates a 16 MHz signal through a series of stages, consisting of a filter and a comparator. The 10 MHz reference signal from the A15 RF assembly is first prescaled by 2.5 to yield a 4 MHz signal with a 20 percent duty cycle. This prescaling is performed within U35. The 4 MHz signal is then passed, first, through a high pass filter, and then, through a bandpass filter at 16 MHz. The high pass filter consists of R85, C122, and L14. The bandpass filter consists of L19 and C139. The filter basically filters the fourth harmonic of the 4 MHz signal to generate a 16 MHz signal. The resulting signal is then passed through comparator U34A to generate a 16 MHz square wave. Three more stages, consisting of a bandpass filter followed by a comparator, further filter the signal so that a clean 16 MHz signal results. The 16 MHz signal which is the result of these successive stages of filtering is output at pin 10 of U34. U35 buffers this signal to provide the 16 MHz clock for the CPU. In addition, divide-by-two flip flops are located within U35, which generate 8 MHz and 4 MHz signals.

State- and Trace-Storage Problems

State storage is in the two of the four Program RAMs and trace storage is in the two display RAMs. With low battery voltage, it is normal for states and traces to be retained if the power is off for less than 1 minute. If the power is left off for more than thirty minutes with low battery voltage, the stored states and traces will be lost.

The following steps test battery backup for EC-series instruments:

1. Measure the voltage on W6 at A2J3. If the voltage is less than 2.6 V, check the BT1 battery.
2. If the battery voltage is correct, reconnect W6 to A2J3, turn the analyzer power off and wait 5 minutes.
3. Measure the voltage at A2U19 pin 32 and A2U26 pin 32.
4. If the voltage is less than 2.0 Vdc, the RAM power battery-backup circuitry on the A2 controller assembly is probably at fault.

The following steps test battery backup for E-series instruments:

1. Measure the voltage on W6 at A2J10. If the voltage is less than 2.6 V, check the BT1 battery.
2. If the battery voltage is correct, reconnect W6 to A2J10, turn the analyzer power off and wait 5 minutes.
3. Measure the voltage at A2U101 pin 28 and A2U102 pin 28.
4. If the voltage is less than 2.0 Vdc, the RAM power battery-backup circuitry on the A2 controller assembly is probably at fault.

Keyboard Problems

If the analyzer does not respond to keys being pressed or the knob being rotated, the fault could be either on the A3 interface assembly or the A2 controller assembly. To isolate the A2 controller assembly, use the following procedure. This procedure tests the analyzer response over HP-IB and the keyboard/RPG interrupt request signal.

1. Enter and run the following BASIC program:

```
10 OUTPUT 718; "IP; SP 1 MHz;"
20 WAIT 2 ! Wait 2 seconds
30 OUTPUT 718;"AT 70 DB;"
40 WAIT 2 ! Wait 2 seconds
50 OUTPUT 718;"AT 30 DB;"
60 WAIT 2 ! Wait 2 seconds
70 OUTPUT 718;"AT 10 DB;"
80 END
```

2. When the program runs, three or four clicks should be heard. This is the A9 input attenuator changing attenuation value.
3. If the display shows the analyzer to be in RMT and the ATTEN value displayed on the LCD (CRT on E-series instruments) changed according to the program, the A2 controller assembly is working properly. Refer to Chapter 8, "ADC/Interface Section."
4. If there was no response over HP-IB, the A2 controller is probably defective. Be sure to also check the A19 HP-IB assembly and A19W1.
5. If there was an improper response (for example, the displayed ATTEN value changed but no clicks were heard), the A2 controller is probably working properly.
6. On EC-series instruments, attach a logic probe to A2U35 pin 213. On E-series instruments, attach a logic probe to A2U2 pin 2.

Look for pulses while pressing a key and rotating the knob (RPG). This is the interrupt request signal for the keyboard and RPG.
7. If the interrupt request signal is always low, troubleshoot the A2 controller assembly.
8. If the interrupt request signal is always high, the fault is on either the A3 interface or A1A1 keyboard assembly.

Figure 9-12 **A2 Controller Block Diagram (E-Series)**

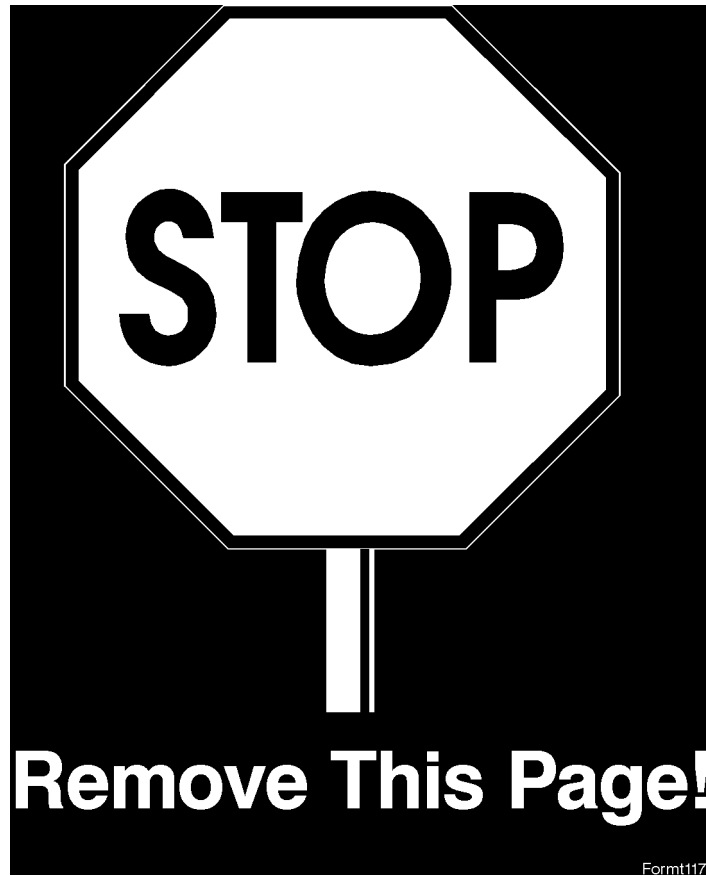

replace with sj125e

Controller Section
Keyboard Problems

Figure 9-13 **A2 Controller Block Diagram (EC-Series)**

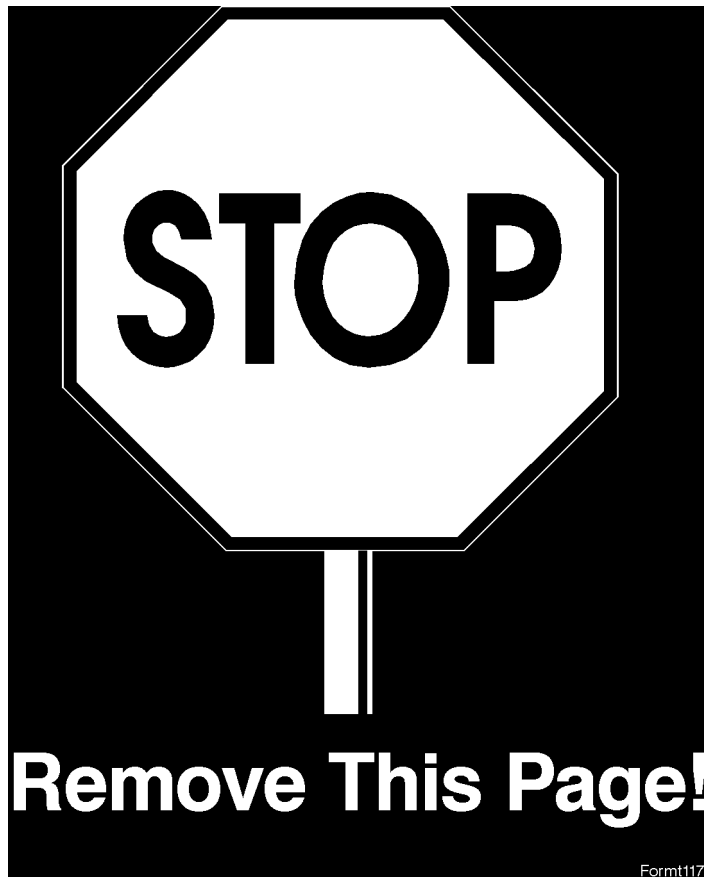

replace with sj118c

Controller Section
Keyboard Problems

10

Synthesizer Section

Introduction

The synthesizer section includes the A7 first LO distribution amplifier, A11 YTO, and parts of the A14 frequency control and A15 RF assemblies. Simplified and detailed block diagrams for each assembly are located at the end of this chapter.

| | |
|--|----------|
| Synthesizer Troubleshooting Section..... | page 508 |
| Test Setup Troubleshooting..... | page 514 |
| Troubleshooting Using the TAM..... | page 515 |
| General PLL Troubleshooting..... | page 520 |
| PLL Locked at Wrong Frequency..... | page 520 |
| Unlocked PLL..... | page 521 |
| Unlocked Reference PLL (100 MHz VCXO) | page 524 |
| Operation (100 MHz VCXO)..... | page 524 |
| Troubleshooting (100 MHz VCXO)..... | page 524 |
| Third LO Driver Amplifier (100 MHz VCXO) | page 528 |
| Unlocked Reference PLL (600 MHz SAWR) | page 529 |
| Operation (600 MHz SAWR)..... | page 529 |
| Troubleshooting (600 MHz SAWR) | page 529 |
| Third LO Driver Amplifier (600 MHz SAWR) | page 533 |
| Unlocked Offset Lock Loop (Sampling Oscillator) | page 534 |
| Operation..... | page 534 |
| Troubleshooting..... | page 534 |
| Unlocked YTO PLL | page 538 |
| Operation..... | page 538 |
| Troubleshooting an Unlocked YTO PLL..... | page 540 |
| Unlocked Fractional N PLL..... | page 547 |
| Operation..... | page 547 |
| Confirming an Unlocked Condition..... | page 547 |
| Fractional N PLL | page 548 |
| Frequency Span Accuracy Problems..... | page 555 |
| Determining the First LO Span | page 555 |
| Confirming Span Problems..... | page 556 |
| YTO Main Coil Span Problems (LO Spans >20 MHz) | page 556 |
| YTO FM Coil Span Problems (LO Spans 2.01 MHz to 20 MHz)..... | page 557 |
| Fractional N Span Problems (LO Spans \leq 2 MHz) | page 559 |
| First LO Span Problems (All Spans)..... | page 559 |
| Phase Noise Problems..... | page 561 |
| Phase Noise in Locked versus Lock-and-Roll Spans..... | page 561 |
| Reference versus Reference PLL Phase Noise | page 562 |
| Fractional N versus Offset PLL or YTO PLL Phase Noise | page 562 |
| Fractional N PLL Phase Noise..... | page 562 |
| Sampler and Sampler IF | page 563 |
| Sweep Generator Circuit | page 565 |
| A21 OCXO | page 574 |

CAUTION All of the assemblies are extremely sensitive to electrostatic discharge (ESD). For further information regarding electrostatic cautions, refer to "Electrostatic Discharge Information" in Chapter 1.

CAUTION Using an active probe, such as an HP 85024A, with a spectrum analyzer is recommended for troubleshooting the RF circuitry. If an HP 1120A active probe is being used with a spectrum analyzer, such as the HP 8566A/B, or HP 8569A/B having dc coupled inputs, either set the active probe for an ac coupled output or use a dc blocking capacitor (HP 11240B) between the active probe and the spectrum-analyzer input. Some spectrum analyzers can be set to ac coupled. Failure to do this can result in damage to the spectrum analyzer or the probe.

Synthesizer Troubleshooting Section

The A11 YTO (the HP 8560E/EC first LO) is a YIG-tuned oscillator which tunes from 2.95 to 6.8107 GHz. The A7 LO distribution amplifier (LODA) levels the output of A11 and distributes the signal to the A8 low band mixer, A10 YIG-tuned mixer/filter, A15U100 sampler, and the 1ST LO OUTPUT on the front panel. The synthesizer section includes the following PLLs (Phase Locked Loops):

| | |
|---|---------------------------------|
| YTO PLL | A7, A11, A14 and A15 assemblies |
| Offset PLL (sampling oscillator PLL) | A15 RF assembly |
| Fractional N PLL | A14 frequency control assembly |
| Reference PLL | A15 RF assembly |

The fractional N PLL is sometimes swept backwards (higher frequency to lower frequency). This is necessary because of the way in which the sampler IF signal is produced.

NOTE

The frequency control board is digitally controlled. If multiple failures appear in unrelated areas of the circuitry, the control may be at fault. Refer to the troubleshooting procedures in this chapter for further help on isolating those failures.

The TAM tests the signal path circuitry by digitally controlling the hardware and monitoring the control lines to make sure they are responding properly. Use the TAM automatic fault isolation routine or verify the RF levels manually to ensure proper operation.

Check A3 ADC MUX function block (steps 1-4)

1. Connect positive lead of a DVM to A15J200 pin 13, and the negative lead to A15J200 pin 6. This measures the sampling oscillator tune voltage, which is an input to the ADC MUX of the A3 interface assembly.
2. Set the HP 8560E/EC to the following settings:
 - Span 0 Hz
 - Center frequency 389.5 MHz
 - Trigger Single
3. Use the data entry keys to tune the **CENTER FREQ** to the values listed in [Table 10-1 on page 509](#).

4. As the sampling oscillator frequency is increased, the DVM reading should also increase. If the tune voltage is correct, but the ADC measures the voltage and determines it to be out of specification, troubleshoot the A3 assembly ADC MUX.

Table 10-1 Center Frequency Tuning Values

| HP 8560E/EC Center Frequency (MHz) | Sampling Oscillator Frequency (MHz) |
|---|--|
| 2156.3 | 285.000 |
| 2176.3 | 286.364 |
| 2199.5 | 287.500 |
| 2230.3 | 288.462 |
| 799.3 | 288.889 |
| 2263.3 | 290.000 |
| 2282.3 | 290.909 |
| 2302.3 | 291.667 |
| 2155.3 | 292.500 |
| 2158.3 | 293.478 |
| 2336.3 | 294.444 |
| 2196.3 | 295.000 |
| 1.3 | 296.000 |
| 2378.3 | 296.471 |
| 2410.3 | 297.000 |
| 2422.3 | 297.222 |

Check A14J301 10 MHz reference input (steps 5-8)

5. Disconnect W37 from A14J301.
6. Connect a test cable from W37 to the input of another spectrum analyzer. Tune the other spectrum analyzer to the following settings:
 - Center frequency 10 MHz
 - Span 2 MHz
7. The amplitude of the 10 MHz reference signal should measure >-1 dBm. If the signal does not measure >-1 dBm, troubleshoot the A15 10 MHz distribution, and A21 OCXO (if not Option 103).
8. Reconnect W37 to A14J301.

Check first LO (steps 9-11)

9. Connect the CAL OUTPUT to INPUT 50 Ω

10. Set the HP 8560E/EC to the following settings:

Center frequency 300 MHz
Span 100 MHz
Trigger CONT

11. If the first LO is present, a signal should be displayed at about -10 dBm (approximately ± 20 MHz from the center frequency). If no signal is displayed and ERR 334 LO AMPL is not present, suspect the A7 LODA. If no signal is displayed and ERR 334 LO AMPL is present, check the A11 YTO as follows:

- a. Set jumper A14J23 to the TEST position.
- b. Set the HP 8560E/EC to the following settings:

Center frequency 50 Hz
CF step 300 MHz
Span 0 Hz

- c. Connect a power meter directly to the output of the A11 YTO.
- d. Press the HP 8560E/EC step-up key and measure the YTO output power at each step.
- e. Verify that the output power of the A11 YTO is between $+9$ and $+13$ dBm.
- f. Set jumper A14J23 to the NORM position and reconnect the A11 YTO.

Check A14 frequency control assembly (steps 12-17)

12. On the HP 8560E/EC, press PRESET, SPAN, ZERO SPAN, CAL, MORE 1 OF 2, FREQ DIAGNOSE, and FRAC N FREQ. Note the fractional N oscillator frequency. (Ignore the minus sign, if present.)

Fractional N Oscillator Frequency = _____ MHz

13. Check A14J304 (FRAC N TEST) port with a spectrum analyzer for this exact frequency. The amplitude should be approximately -10 dBm.

14. Disconnect W32 from A14J501 and connect the output of a signal source to A14J501. Remove the jumper from A14J23. Connect the positive lead of a DVM to A14J23 pin 1, and the negative lead to A14J23 pin 3. See [Figure 10-1 on page 511](#).

15. Set the signal source to the following settings:

Power 0 dBm
Frequency Frequency recorded in step 12

16. Tune the source to 1 kHz less than the fractional N frequency. The voltage measured on the DVM should be approximately 12 Vdc.
17. Tune the source to a frequency 1 kHz greater than the fractional N frequency. The voltage measured on the DVM should be approximately -12 Vdc.
18. If the DVM reading does not change, the A14 frequency control assembly is defective. Reconnect W32 to A14J501.

Figure 10-1 YTO Loop Test Setup

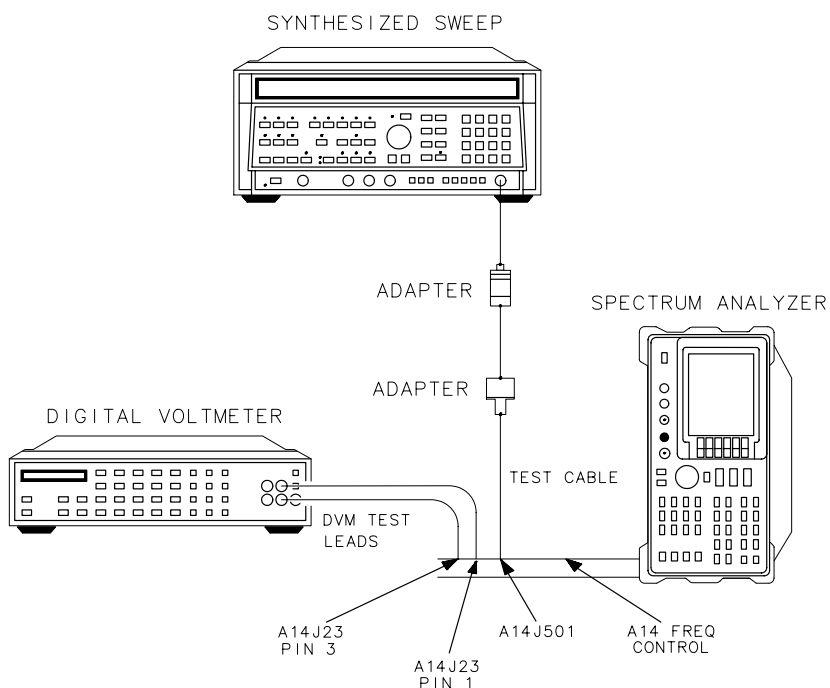

sp127e

Check A15 RF assembly (steps 18-25)

19. Disconnect W34 from A15U100J1 and disconnect W32 from A15J101.
20. Connect a frequency counter to A15J101. Connect a high-frequency test cable from an HP 8340A/B synthesized sweeper to A15U100J1. See [Figure 10-2 on page 512](#).
21. Connect a BNC cable from the HP 8560E/EC 10 MHz REF IN/OUT to the HP 8340A/B FREQUENCY STANDARD EXT input.
22. Set the HP 8340A/B to the following settings:

Frequency standard EXT
 Power level -5 dBm

23. Set the HP 8560E/EC to the following settings:

Span 0 Hz
 Trigger Single

24. Set the HP 8560E/EC and HP 8340A/B frequencies to the combinations listed in Table 10-2 on page 513 and press SGL SWP on the spectrum analyzer.

Figure 10-2 Sampler and Sampling Oscillator Test Setup

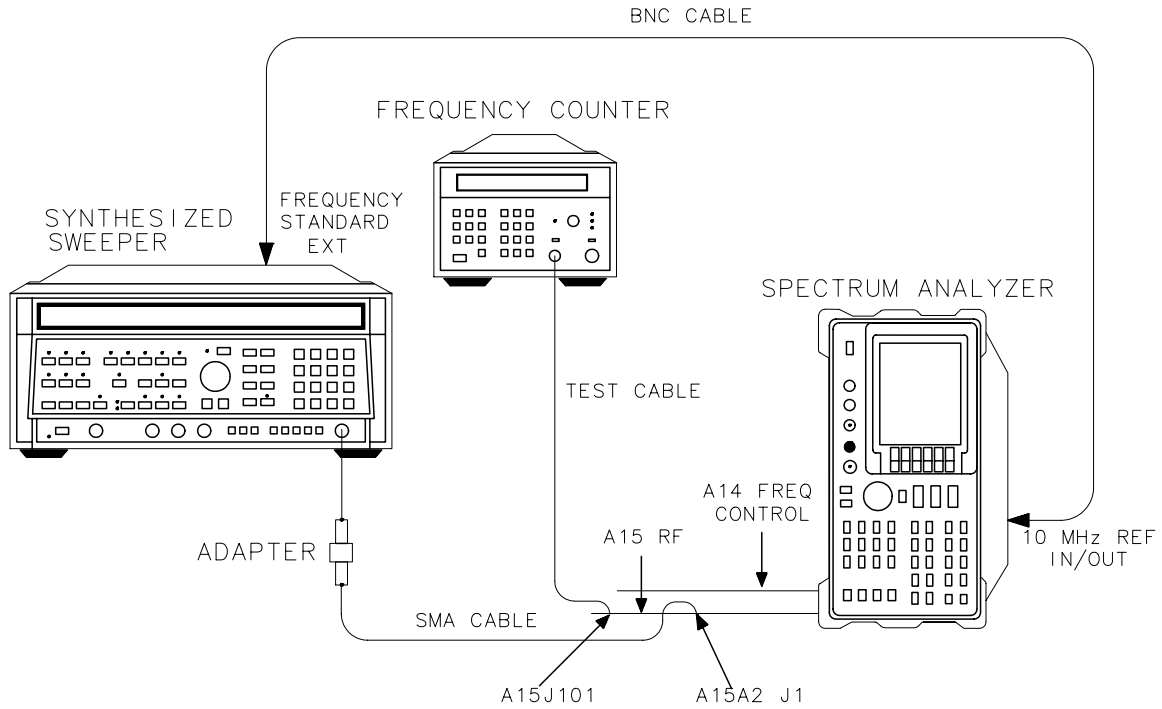

25. At each combination, the frequency counter should measure a sampler IF as shown in Table 10-2 on page 513. (The sampling oscillator of the offset PLL tunes to the frequencies listed in the table.) If the frequency counter does not read the indicated sampler IF ± 10 kHz, suspect the A15 RF assembly.

26. Reconnect W34 to A15U100J1 and W32 to A15J101.

27. The 1ST LO OUTPUT, located on the front panel, must be terminated in 50 Ω . If the YTO unlocks only with certain center frequency and span combinations, check that the termination is in place.

28. Set the HP 8560E/EC CENTER FREQ and SPAN to generate the unlock conditions.

29. On the HP 8560E/EC, press **SGL SWP**.
30. Move jumper A14J23 to the TEST position.
31. Disconnect W34 from A15U100J1 and measure the power of the signal at the end of W34.
32. If the power is less than -6.5 dBm, suspect W34, A7 LODA, or A11 YTO.
33. Move jumper A14J23 to the NORM position.

Table 10-2

Sampling Oscillator Test Frequencies

| HP 8340A CW Frequency (GHz) | HP 8560E/EC Center Frequency (MHz) | Offset PLL Sampling Oscillator Freq (MHz) | Counter Reading Sampler IF (MHz) |
|------------------------------------|---|--|---|
| 6.067000 | 2156.3 | 285.000 | 82.000 |
| 6.087000 | 2176.3 | 286.364 | 73.364 |
| 6.110200 | 2199.5 | 287.500 | 72.700 |
| 6.141000 | 2230.3 | 288.462 | 83.308 |
| 4.710000 | 799.3 | 288.889 | 87.778 |
| 6.174000 | 2263.3 | 290.000 | 84.000 |
| 6.193000 | 2282.3 | 290.909 | 83.909 |
| 6.213000 | 2302.3 | 291.667 | 88.000 |
| 6.066000 | 2155.3 | 292.500 | 76.500 |
| 6.069000 | 2158.3 | 293.478 | 94.044 |
| 6.247000 | 2336.3 | 294.444 | 63.667 |
| 6.107000 | 2196.3 | 295.000 | 88.000 |
| 3.912000 | 1.3 | 296.000 | 64.000 |
| 6.289000 | 2378.3 | 296.471 | 63.118 |
| 6.321000 | 2410.3 | 297.000 | 84.000 |
| 6.333000 | 2422.3 | 297.222 | 91.333 |

Test Setup Troubleshooting

Some synthesizer section problems require placing the YTO PLL in an unlocked condition. Do this by moving jumper A14J23 to the TEST position. This grounds the YTO ERROR signal and stops the CPU from detecting an unlocked YTO. The FM coil driver output is set to its mid-range level causing the YTO to be controlled only by the main coil tune DAC.

It is best to troubleshoot the synthesizer section with the HP 8560E/EC span set to 0 Hz (even though it is still possible to sweep the Main and FM coils of the YTO).

With the YTO in its unlocked conditions and the span set to 0 Hz, the nominal YTO frequency is not necessarily the value listed as LO FREQ in the Frequency Diagnose menu. The YTO has an initial pretune accuracy of ± 20 MHz. To display the nominal YTO frequency, press **CAL, MORE 1 OF 2, FREQ DIAGNOSE, LO FREQ**.

The fractional N oscillator frequency is the same as the desired sampler IF. To display the fractional N oscillator frequency press **CAL, MORE 1 OF 2, FREQ DIAGNOSE, FRAC N FREQ**. If the sampler IF is negative (YTO frequency is lower than the desired sampling oscillator harmonic), the fractional N frequency will be displayed as a negative number.

Troubleshooting Using the TAM

When using automatic fault isolation, the TAM indicates suspected circuits that need to be manually checked. Use [Table 10-4 on page 516](#) to locate the manual procedure.

[Table 10-5 on page 517](#) lists assembly test connectors associated with each manual probe troubleshooting test. [Figure 10-3 on page 515](#) illustrates the location of A14 and A15 test connectors.

The pin locations of a 16-pin TAM connector are indicated in [Figure 10-4 on page 516](#). [Table 10-3 on page 516](#) indicates the correspondence between a measured signal line and the TAM connector pin.

Figure 10-3 A14 and A15 Test Connectors

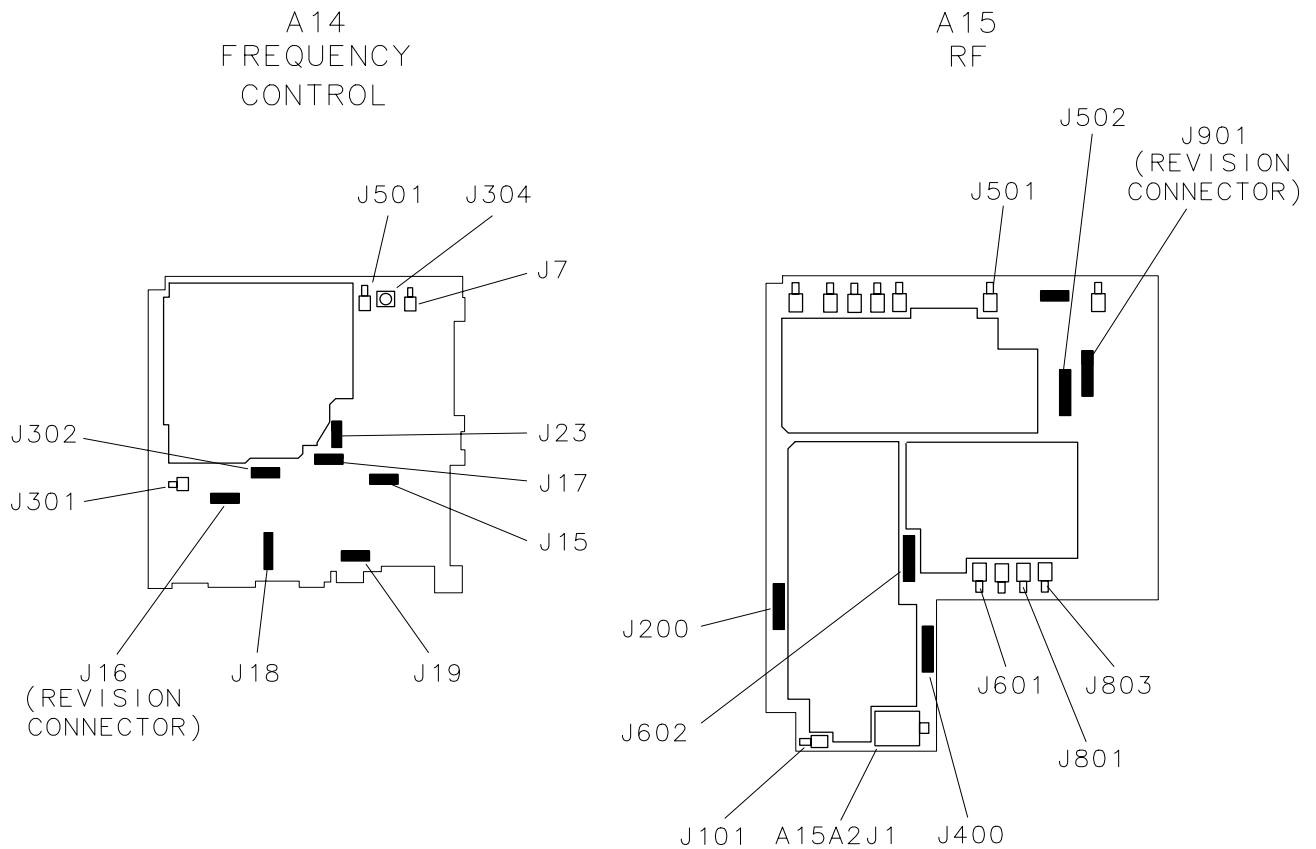

sp128e

Figure 10-4 TAM Connector Pin Locations

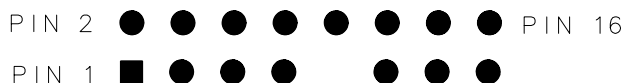

Table 10-3 Measured Signal Line Location

| Measured Signal Line | Connector Pin |
|----------------------|---------------|
| MSL1 | pin 1 |
| MSL2 | pin 2 |
| MSL3 | pin 3 |
| MSL4 | pin 4 |
| MSL5 | pin 5 |
| GND | pin 6 |
| MSL6 | pin 13 |
| MSL7 | pin 14 |
| MSL8 | pin 15 |

Table 10-4 Automatic Fault Isolation References

| Suspected Circuit Indicated by Automatic Fault Isolation | Manual Procedure to Perform |
|--|---|
| Check the YTO loop Check first LO | Confirming a Faulty Synthesizer Section <i>(steps 9-11)</i> |
| Check first LO pretune frequency and amplitude | Unlocked YTO PLL <i>(steps 10-13)</i> |
| Check 3rd LO drive | Third LO Driver Amplifier <i>(steps 1-6)</i> |
| Check 10 MHz reference to phase/frequency detector | Unlocked Reference PLL <i>(steps 8-13)</i> |
| Check for 10 MHz signal at other input to phase/frequency detector | Unlocked Reference PLL <i>(steps 12 and 13)</i> |
| Check A3 ADC MUX function block | Confirming a Faulty Synthesizer Section <i>(steps 1-4)</i> |
| Check A14 frequency control assembly | Confirming a Faulty Synthesizer Section <i>(steps 12-17)</i> |
| Check A14J301 10 MHz REF input | Confirming a Faulty Synthesizer Section <i>(steps 5-8)</i> |
| Check A15 RF assembly | Confirming a Faulty Synthesizer Section <i>(steps 18-25)</i> |

Table 10-4 Automatic Fault Isolation References

| Suspected Circuit Indicated by Automatic Fault Isolation | Manual Procedure to Perform |
|---|--|
| Check current source | First LO Span Problems (All Spans) (steps 14-21) |
| Check FM loop sense | Unlocked YTO PLL (steps 28-34) |
| Check level at amplifier Input | Third LO Driver Amplifier (steps 1-6) |
| Check levels into mixer U400 | Unlocked Offset PLL (steps 3-13) |
| Check loop references | Unlocked Offset PLL (steps 1 and 2) |
| Check main coil tune DAC | Unlocked YTO PLL (steps 45-49) |
| Check main coil coarse and fine DACs | Unlocked YTO PLL (steps 41-44) |
| Check offset span accuracy | First LO Span Problems ≤ 2 MHz (step 8) |
| Check phase/frequency detector | Unlocked Reference PLL (steps 17-22) |
| Check path to phase/frequency detector | Unlocked Offset PLL (steps 3-7, 14-19) |
| Check fractional N oscillator | Unlocked YTO PLL (steps 14-18) |
| Check sampler drive output of A7 LODA | Unlocked YTO PLL (steps 19-22) |
| Check sampler IF | Unlocked YTO PLL (steps 23-27) |
| Check sampler/sampler IF operation | Sampler and Sampler IF (steps 1-15) |
| Check span attenuator | First LO Span Problems (All Spans) (steps 6-13) |
| Check sweep generator | Sweep Generator Circuit |
| Check the 600 MHz reference loop amplifier | Unlocked Reference PLL (steps 23-26) |
| Check the YTO loop | Unlocked YTO PLL |
| Check YTO FM coil driver | First LO Span Problems (2.01 MHz to 20 MHz) (step 6) |
| Check YTO FM coil driver and main loop error voltage driver | Unlocked YTO PLL (steps 35-40) |

Table 10-5 TAM Tests versus Test Connectors

| Connector | Manual Probe Troubleshooting Test | Measured Signal Lines |
|------------------|--|------------------------------|
| A14J15 | Sweep generator | MS8 |
| | Span attenuator DAC | MS7 |
| | Span attenuator switches | MS7 |
| | Sweep + tune mult input amp | MS1, OS1 |
| | Sweep + tune mult input switches | MS1, MS3 |
| A14J16 | FAV generator | MS4 |
| | FAV gen 0.5 V/GHz output | MS5 |
| A14J17 | Main coil coarse DAC | MS3 |
| | Main coil fine DAC | MS2 |
| | Main coil DACs output | MS5 |

Table 10-5 TAM Tests versus Test Connectors

| Connector | Manual Probe Troubleshooting Test | Measured Signal Lines |
|--|-----------------------------------|-----------------------|
| | Main loop error volt DVR | MS4 |
| | Option drive | MS8 |
| | Option drive switch | MS7 |
| | Option drive DAC | MS6 |
| A14J18 | ±10 V reference | MS1, MS2 |
| | LODA drive | MS5, MS6, MS7, MS8 |
| | Main coil tune DAC | MS3 |
| | Sweep gen DAC | MS4* |
| | Sweep gen DAC | MS4* |
| A14J19 | Second conv PIN switch | MS8 |
| | Second conv mixer bias | MS1 |
| | Second conv drain bias | MS3 |
| | Second conv doubler bias | MS4 |
| | Second conv driver bias | MS5 |
| | First mixer drive switch | MS7 |
| | First mixer drive DAC | MS6 |
| A14J302 | Revision | MS7 |
| | Fractional N out | MS1 |
| | Divided reference | MS4 |
| | Feedback buffer bias | MS5 |
| | Outamp bias | MS6 |
| A15J200 | Positive 15 volt supply | MS1 |
| | Sampler drive buffer bias | MS2 |
| | Sampling oscillator bias | MS3 |
| | Offset lock drive buffer | MS4 |
| * Only on A14 assemblies with part numbers 08560-60059, 08560-69059, 08560-60062, 08560-69062. | | |

Table 10-5 TAM Tests versus Test Connectors

| Connector | Manual Probe Troubleshooting Test | Measured Signal Lines |
|--|------------------------------------|-----------------------|
| A15J200 | OFL error voltage | MS6 |
| | Negative 10 volt supply | MS8 |
| | Offset lock loop BW DAC | MS5,MS7,MS8 |
| A15J400 | Positive 15 volt supply | MS2 |
| | Offset lock RF buffer | MS4 |
| | IF AMP/limiter bias | MS6 |
| | Offset lock loop buffer D | MS7 |
| | Offset lock loop buffer C | MS8 |
| | Sampler bias test | MS3 |
| A15J502 | Positive 15 volt supply | MS2 |
| | Third LO tune voltage | MS3 |
| | Offset lock loop buffer | MS4 |
| | 600 MHz oscillator bias | MS5 |
| | Calibrator AGC amp bias | MS6 |
| | Calibrator ampl adj | MS7 |
| | 3rd LO driver amp | MS1, MS8 |
| A15J602 | Positive 15 volt supply | MS8 |
| | Flatness compensation 3 | MS2 |
| | Flatness compensation 2 | MS5 |
| | Flatness compensation 1 | MS6 |
| | SIG ID collector bias (Option 008) | MS7 |
| | RF gain control test | MS1, MS3 |
| A15J901 | Revision | MS3 |
| | External mixer switch | MS1, MS8 |
| | Signal ID switch (Option 008) | MS5, MS6 |
| | Ten volt reference | MS4 |
| | External mixer bias | MS7 |
| * Only on A14 assemblies with part numbers 08560-60059, 08560-69059, 08560-60062, 08560-69062. | | |

General PLL Troubleshooting

The synthesizer section relies heavily on phase-locked loops (PLL). Typically, faulty PLLs are either locked at the wrong frequency or unlocked. The information below applies to troubleshooting these two classes of problems on a generalized PLL.

PLL Locked at Wrong Frequency

Numbers in the following text identify items in [Figure 10-5 on page 521](#).

- Any frequency errors at reference (1) will be multiplied by N/M on the PLL output.
- A sampler reference-frequency error (2) will be multiplied by its harmonic on the PLL output.
- A mixer reference-frequency error (3) produces the identical error on the PLL output.
- If divider input or output frequencies (4) are wrong, check for incorrect divide numbers and data controlling the dividers.

Figure 10-5 PLL Locked at Wrong Frequency

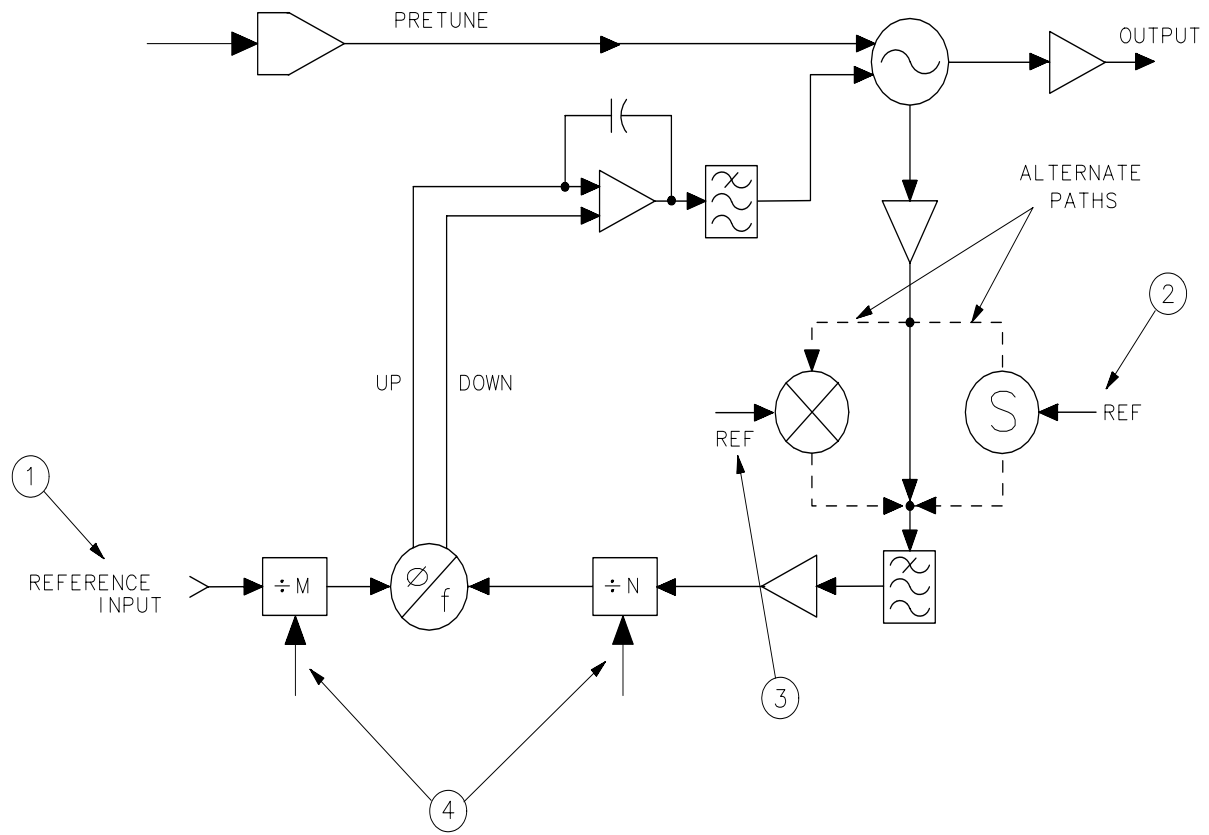

sp129e

Unlocked PLL

An unlocked PLL can be caused by problems inside or outside the PLL. Troubleshoot this problem by working backward from the oscillator as described in the steps below. Numbers in the following text identify items in [Figure 10-6 on page 522](#).

1. The loop integrator output voltage (1) should be attempting to tune the oscillator to the correct frequency.
 - The voltage at (1) should increase as the frequency increases on all of the PLLs:

Table 10-6 TAM Tests versus Test Connectors

| PLL | Measurement Point |
|------------------|--------------------------|
| YTO PLL | A14J23 pin 1 (YTO ERROR) |
| Reference PLL | A15J502 pin 3 (LO3 ERR) |
| Sampler PLL | A15J200 pin 13 (OFL ERR) |
| Fractional N PLL | A14TP13 (INTEGRATOR) |

Figure 10-6 Unlocked PLL

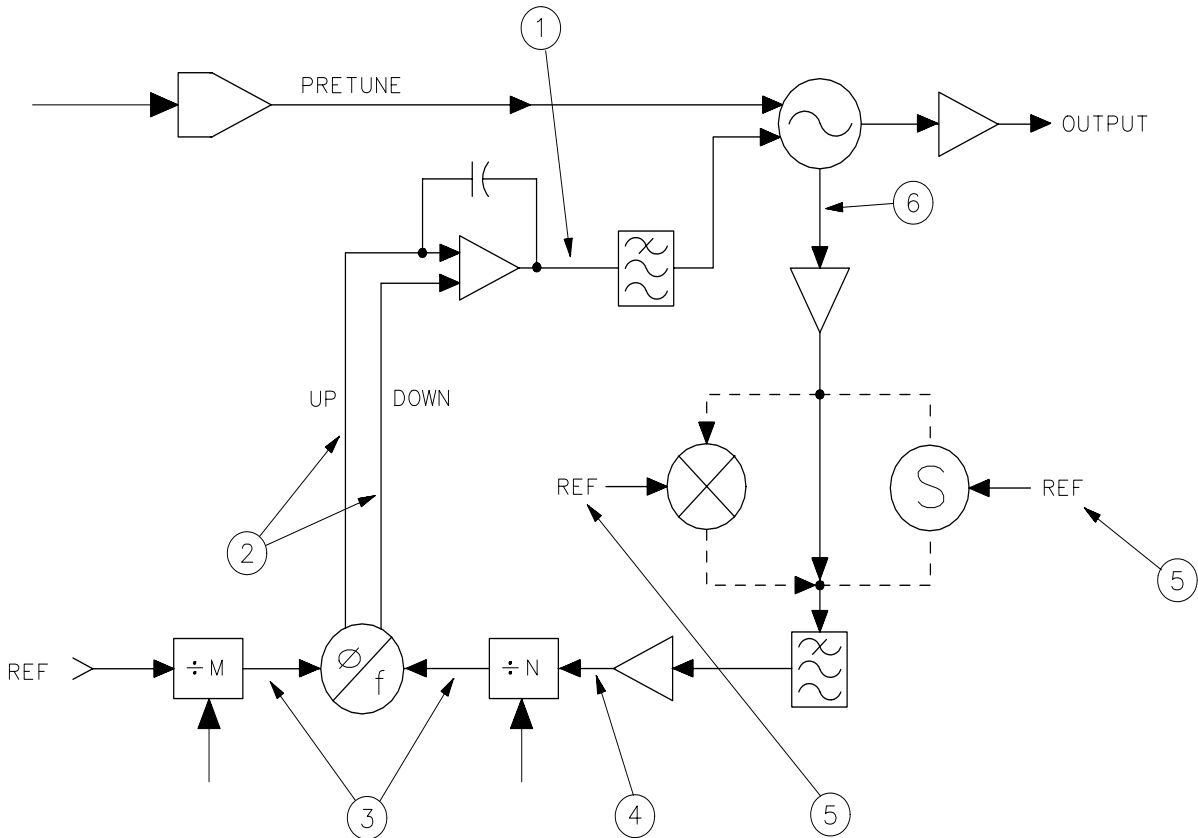

sp130e

2. If the integrator output voltage changes in the manner described in

step 1, the problem is external to the PLL. For example, the reference frequency could be faulty. If the integrator output voltage appears incorrect, confirm that the pulses out of the phase detector (2) are attempting to tune the oscillator in the correct direction.

3. If the phase detector output is bad, check the inputs to the detector (3). One input should be higher in frequency than the other; this should match the phase detector outputs.
4. Confirm proper power levels for the signals at the input to the "N" dividers (4), the reference inputs (5 and 7), and the loop feedback path (6).

Unlocked Reference PLL (100 MHz VCXO)

NOTE

The following information is for A15 RF assemblies 08563-60054 and later. For earlier A15 RF assemblies, proceed to *Unlocked Reference PLL (600 MHz SAWR)* in this chapter.

Operation (100 MHz VCXO)

The 600 MHz reference is generated by tripling, then doubling the output of the 100 MHz phase-locked loop. If the 600 MHz reference is off frequency, the 100 MHz phase-lock circuitry is probably at fault. If there is no signal present at A15J701, or if the level is less than -3 dBm, the 100 MHz VCXO, the tripler, or the doubler circuitry has probably failed. Refer to function blocks Q, R, and S of the A15 RF schematic (sheet 2 of 4) in the *HP 8560 E-Series Spectrum Analyzer Component Level Information*.

Troubleshooting (100 MHz VCXO)

Check 100 MHz VCXO, tripler, and doubler (steps 1-7)

1. Using an active probe/spectrum analyzer combination, such as the HP 85024A/HP 8566B, measure the tripler output at A15TP700. The tripler output should be $+3$ dBm ± 2 dB.
2. If the tripler output is within tolerance, suspect the doubler circuitry. Refer to function block S of the A15 RF schematic (sheet 2 of 4).
3. If the tripler output is too low, probe the output of A15U700 RF amplifier. The level should be $+16.5$ dBm ± 2 dB. The level at the input of A15U700 should be $+8.5$ dBm ± 2 dB.
4. If the level at the input of A15U700 is too low, suspect a faulty 100 MHz VCXO. Refer to function block Q of the A15 RF schematic (sheet 2 of 4).
5. On the spectrum analyzer, press **AUX CTRL**, **REAR PANEL**, and **10 MHz INT**.
6. Measuring the tune voltage indicates if the 100 MHz PLL is locked. Connect the ground lead the voltmeter to A15J1 pin 3 and measure the voltage at A15J700 pin 3.
7. The tune voltage should be between $+1$ and $+24$ Volts. If the tune voltage is incorrect, place the P700 jumper (on A15J700) in the **TEST** position (pin 1 to pin 2). This sets the tune voltage for varactor A15CR700 to the nominal $+13$ Volts, making it easier to troubleshoot the 100 MHz VCXO, tripler, and doubler. Remember to return P700 jumper to the **NORMAL** position when you have finished troubleshooting the oscillator circuitry.

8. If the 100 MHz oscillator is working, the reason for the unlocked condition is either a problem in the 10 MHz reference or a fault in the signal path around the loop.

Check 10 MHz reference to phase/frequency detector (steps 9-14)

9. On the spectrum analyzer, press **AUX CTRL, REAR PANEL,** and **10 MHz INT.**
10. Check the 10 MHz reference frequency accuracy by connecting a frequency counter to A15J301 and verify that the reference frequency is 10 MHz \pm 40 Hz after a 5 minute warm-up period.
11. If a 10 MHz signal >1 V peak-to-peak is not present at A15J301, refer to the "10 MHz Reference" in Chapter 11.
12. Measure the signal at TP301 with an oscilloscope. Refer to function block M of A15 RF schematic.
13. Measure the signal at U502 pin 11 with an oscilloscope. Refer to function block X of A15 RF schematic. This signal should be TTL levels at 10 MHz with a 60 percent duty cycle.
14. If TTL-level signals (approximately 10 MHz) are not present, check signals backwards through the loop to find a fault in the signal path.
15. Measure the signals at the following test points with an active probe/spectrum analyzer combination:

| | |
|--|-------------------------------|
| Junction of C570 and C571 | 100 MHz, +2.5 dBm \pm 2 dB |
| Junction of R715, R716, R567, and R568 | 100 MHz, -3 dBm \pm 2 dB |
| U700 pin 3 | 100 MHz, +16.5 dBm \pm 2 dB |
| U700 pin 1 | 100 MHz, +8.5 dBm \pm 2 dB |

16. If an approximately 10 MHz TTL signal is present at U502 pin 11 with 60 percent duty cycle, and the RF portion of the phase-lock loop is functioning, the fault probably lies in the phase/frequency detector or the 100 MHz lock loop integrator.

Check phase/frequency detector (steps 17-22)

17. Monitor U504 pin 5 and U503 pin 9 with an oscilloscope. These are the two outputs of the phase/frequency detector. Refer to function block O of A15 RF schematic.
18. A locked loop will exhibit stable, narrow (approximately 20 ns wide), and positive-going TTL pulses occurring at a 10 MHz rate at U504 pin 5 and U503 pin 9.
19. If the loop is unlocked, but signals are present on both inputs of the phase/frequency detector, the output pulses will be superimposed on each other.

20. If the loop is unlocked, and there is no signal at one of the phase/frequency detector inputs, one phase detector output will be at TTL low and the other will be at TTL high. For example, if there is no input signal at U504 pin 3, U504 pin 5 will be TTL low and U503 pin 9 will be TTL high. If there is no input signal at U503 pin 11, U503 pin 9 will be TTL low and U504 pin 5 will be TTL high.
21. To remove the 10 MHz reference input to the phase/frequency detector, press **AUX CTRL**, **REAR PANEL**, and **10 MHz EXT** with no signal applied to the rear panel 10 MHz REF IN/OUT connector.
22. To remove the divided-down 100 MHz signal from the phase/frequency detector, short R595. Refer to function block X of A15 RF schematic.
23. Remove 10 MHz reference input to the phase/frequency detector by pressing **AUX CTRL**, **REAR PANEL**, and **10 MHz EXT**. No signal should be connected to the rear panel 10 MHz REF IN/OUT connector.

Check the 100 MHz lock loop integrator (steps 23-27)

NOTE

The outputs of phase/frequency detector are low-pass filtered to reduce the 10 MHz component of the signal. The filtered signals are then integrated by U506 and the result is fed to the tune line of the 100 MHz VCXO.

24. Check that the voltage on A15J502 pin 3 is less than 0 Vdc. Refer to function block P of A15 RF schematic.
25. Press **AUX CTRL**, **REAR PANEL**, and **10 MHz INT** and remove the divided-down 100 MHz input to the phase/frequency detector by shorting R572.
26. Check that the voltage on A15J502 pin 3 is greater than 13 Vdc.
27. If the loop is locked, the voltage on A15J502 pin 3 should be between 0 and +6 Vdc.
28. If the front panel CAL OUTPUT amplitude is out of specification and cannot be brought within specification by adjusting A15R561, CAL AMPD, check the calibrator AGC amplifier with the following steps. Refer to function block W of A15 RF schematic.

NOTE

The 300 MHz CAL OUTPUT signal comes from the tripled 100 MHz which is passed through a leveling loop. The 300 MHz signal passes through a low-pass filter for reducing higher harmonics. These harmonics can fool the detector. The 300 MHz signal passes through a variable attenuator controlled by PIN diode CR503 which is controlled by the feedback loop. Diode CR504 is the detector diode (the same type as CR505). Diode CR504 provides temperature compensation between the reference voltage and the detected RF voltage.

- Measure the level of 300 MHz at A15 TP505 with an active probe/spectrum analyzer combination. If the signal is less than +2 dBm, repeat the first 27 steps of this procedure.
 - If the signal at this point is correct, place a short across the PIN diode CR503.
 - If the signal level at the CAL OUTPUT is still less than -10 dBm with CR503 shorted out, troubleshoot the RF forward path through amplifier Q505. (The signal amplitude decreases.)
 - If the CAL OUTPUT signal level is greater than -10 dBm, troubleshoot the PIN diode attenuator, the detector, or the feedback path.
29. Measure the detector voltage at A15J502 pin 14. The voltage should measure approximately +0.3 Vdc when the CAL OUTPUT signal is at -10 dBm. This voltage should change with adjustment of A15R561, CAL AMPTD.
30. Check that the voltage at U507A Pin 3 is +1.7 Vdc. If this voltage is not correct, there may be a problem with the +10 V reference.
31. Measure voltage at U507B pin 5 while adjusting R561. This is the temperature-compensated adjustable voltage reference to which the detected voltage is compared. It should vary between +0.15 V and +0.6 V.
32. Adjust R561 to its limits and verify that the output U507B pin 7 measures approximately +1 Vdc at one limit and -12 Vdc at the other limit.

Third LO Driver Amplifier (100 MHz VCXO)

The third LO driver amplifier (Q503) amplifies the 300 MHz from the 300 MHz distribution amplifier to a sufficient level to drive the LO port of the double balanced mixer. During the SIG ID operation, diodes CR501 and CR502 turn off the 3rd LO driver amplifier in order to minimize the amount of 300 MHz going to the double-balanced mixer.

Check level at amplifier input (steps 1-6)

1. Press **AUX CTRL, INTERNAL MIXER**. Press **SIG ID OFF**, if option 008 is installed.
2. Use an active-probe/spectrum-analyzer combination to confirm the power level of the 300 MHz signal at the following test points:

A15X602 pin 5 $\geq +7$ dBm

A15TP504 $\geq +15$ dBm

3. If the signal at A15X602 pin 5 is low, but the signal at A15TP504 is correct, press **AUX CTRL, INTERNAL MIXER**. Press **SIG ID OFF**, if present.
4. Check that PIN diode switches CR603 and CR605 are reverse biased by approximately +10 Vdc. Refer to function block F of A15 RF schematic.
5. Measure 300 MHz signal at A15TP503 using an active probe/spectrum analyzer combination. If the signal is not approximately +10 dBm, refer to "Unlocked Reference PLL (100 MHz VCXO)" in this chapter.
6. If the level at the TP503 is correct, but signal at TP504 is too low, the fault is probably in the amplifier.

Unlocked Reference PLL (600 MHz SAWR)

NOTE

The following information is for A15 RF assemblies earlier than 08563-60054, 08563-60055, or 08563-60056. For A15 RF assemblies with the aforementioned HP part numbers or later, refer to *Unlocked Reference PLL (100 MHz VCXO)* earlier in this chapter.

Operation (600 MHz SAWR)

The reference PLL 600 MHz output is generated by a 600 MHz SAWR (surface acoustical wave resonator) VCO. The SAWR provides a high Q feedback path in the oscillator ensuring good phase noise. If the oscillator is off-frequency, the phase-lock circuitry is probably at fault. If there is no signal present at A15J701, or if the level is less than -3 dBm, the oscillator has failed. Transistor Q703 provides active bias for oscillator transistor Q701. Transistor Q704 provides active bias for 600 MHz buffer amplifier Q702. Refer to function blocks Q and R of A15 RF schematic in the *HP 8560 E-Series Spectrum Analyzer Component Level Information*.

Troubleshooting (600 MHz SAWR)

1. If Q701 and Q703 are functioning, check the bias on varactors CR701 and CR702. The varactors should be reverse-biased between 0 V and 18 V, depending on tune voltage.
2. If the active devices are functioning properly, check the SAWR by placing a 100-ohm resistor across U701 pins 1 and 2. This bypasses the SAWR, but provides the equivalent loss of a correctly functioning SAWR.
3. If the oscillator begins to oscillate, the SAWR is probably defective.
4. On the HP 8560E/EC, press **AUX CTRL**, **REAR PANEL**, and **10 MHz INT**.
5. Measuring tune line voltage (LO3 ERR) indicates if the Reference PLL is locked. Measure the voltage at A15J502 pin 3. Connect the ground lead to A15J200 pin 6.
6. If voltage is not between 0 V and 5.75 V, the loop is unlocked and ERR 333 600 UNLK should be displayed on the CRT.
7. If the 600 MHz oscillator is working, the reason for the unlocked condition is either a problem in the 10 MHz reference or a fault in the signal path around the loop.

Check 10 MHz reference to phase/frequency detector (steps 8-13)

8. On the HP 8560E/EC, press **AUX CTRL**, **REAR PANEL**, and **10 MHz INT**.
9. Check the 10 MHz reference frequency accuracy by connecting a frequency counter to A15J301 and verify that the reference frequency is 10 MHz \pm 40 Hz after a 5 minute warm-up period.
10. If a 10 MHz signal >1 V peak-to-peak is not present at A15J301, refer to the "10 MHz Reference" in Chapter 11.
11. Measure the signal on U504 pin 3 with an oscilloscope. Refer to function block O of A15 RF schematic.
12. Measure the signal at U504 pin 11 with an oscilloscope. Refer to function block O of A15 RF schematic. This signal should be TTL levels at 10 MHz with a 90 percent duty cycle.
13. If TTL-level signals (approximately 10 MHz) are not present, check signals backwards through the loop to find a fault in the signal path.
14. Use an oscilloscope to check for 50 MHz TTL level signal at U503 pin 2. Refer to function block X of A15 RF schematic.
15. Measure the signals at the following test points with an active probe/spectrum analyzer combination such as an HP 85024A/HP 8566A/B. The signal level at TP701 should be sufficient to drive an ECL input.

U502 pin 2 50 MHz, $\geq+3$ dBm

U502 pin 15 300 MHz, $\geq+3$ dBm

TP503 300 MHz, approximately +8 dBm

TP502 300 MHz (ECL level), approximately +3 dBm

TP701 600 MHz (ECL level), approximately +3 dBm

16. If an approximately 10 MHz TTL signal is present at U504 pin 11 with 90 percent duty cycle, and the RF portion of the phase-lock loop is functioning, the fault probably lies in the phase/frequency detector or the 600 MHz reference loop amplifier.

Check phase/frequency detector (steps 17-22)

17. Monitor U504 pins 5 and 9 with an oscilloscope. These are the two outputs of the phase/frequency detector. Refer to function block O of A15 RF schematic.
18. A locked loop will exhibit stable, narrow (approximately 20 ns wide), and positive-going TTL pulses occurring at a 10 MHz rate at U504 pins 5 and 9.

- 19.If the loop is unlocked, but signals are present on both inputs of the phase/frequency detector, the output pulses will be superimposed on each other.
- 20.If the loop is unlocked, and there is no signal at one of the phase/frequency detector inputs, one phase detector output will be at TTL low and the other will be at TTL high. For example, if there is no input signal at U504 pin 3, U504 pin 5 will be TTL low and U504 pin 9 will be TTL high. If there is no input signal at U504 pin 11, U504 pin 9 will be TTL low and U504 pin 5 will be TTL high.
- 21.To remove the 10 MHz reference input to the phase/frequency detector, press **AUX CTRL**, **REAR PANEL**, and **10 MHz EXT** with no signal applied to the rear panel 10 MHz REF IN/OUT connector.
- 22.To remove the divided-down 600 MHz signal from the phase/frequency detector, short R572. Refer to function block W of A15 RF schematic.

Check the 600 MHz reference loop amplifier (steps 23-26)

NOTE

The outputs of phase/frequency detector are low-pass filtered to reduce the 10 MHz component of the signal. The filtered signals are then integrated by U506 and the result is fed to the tune line of the 600 MHz oscillator.

- 23.Remove 10 MHz reference input to the phase/frequency detector by pressing **AUX CTRL**, **REAR PANEL**, and **10 MHz EXT**. No signal should be connected to the rear panel 10 MHz REF IN/OUT connector.
- 24.Check that the voltage on A15J502 pin 3 is less than 0 Vdc. Refer to function block P of A15 RF schematic.

Press **AUX CTRL**, **REAR PANEL**, and **10 MHz INT** and remove the divided-down 600 MHz input to the phase/frequency detector by shorting R572.
- 25.Check that the voltage on A15J502 pin 3 is greater than 5.75 Vdc.
- 26.Replace C519 in X501.
- 27.If the loop is locked, the voltage on A15J502 pin 3 should be between 0 V and +5.75 Vdc.

NOTE

The 300 MHz CAL OUTPUT signal comes from the divided down 600 MHz which is passed through a leveling loop. The 300 MHz signal passes through a low-pass filter for reducing higher harmonics. These harmonics can fool the detector. The 300 MHz signal passes through a variable attenuator controlled by PIN diode CR503 which is controlled by the feedback loop. Diode CR504 is the detector diode (the same type as CR505). Diode CR504 provides temperature compensation between the reference voltage and the detected RF voltage.

28. If the front panel CAL OUTPUT amplitude is out of specification and cannot be brought within specification by adjusting A15R561, CAL AMPTD, check the calibrator AGC amplifier with the following steps. Refer to function block W of A15 RF schematic.
- Measure the level of 300 MHz at A15 TP505 with an active probe/spectrum analyzer combination. If the signal is less than +2 dBm, repeat the first 29 steps of this procedure.
 - If the signal at this point is correct, place a short across the PIN diode CR503.
 - If the signal level at the CAL OUTPUT is still less than -10 dBm with CR503 shorted out, troubleshoot the RF forward path through amplifier Q505. (The signal amplitude decreases.)
 - If the CAL OUTPUT signal level is greater than -10 dBm, troubleshoot the PIN diode attenuator, the detector, or the feedback path.
29. Measure the detector voltage at A15J502 pin 14. The voltage should measure approximately +0.3 Vdc when the CAL OUTPUT signal is at -10 dBm. This voltage should change with adjustment of A15R561, CAL AMPTD.
30. Check that the voltage at U507A Pin 3 is +1.7 Vdc. If this voltage is not correct, there may be a problem with the +10 V reference.
31. Measure voltage at U507B pin 5 while adjusting R561. This is the temperature-compensated adjustable voltage reference to which the detected voltage is compared. It should vary between +0.15 V and +0.6 V.
32. Adjust R561 to its limits and verify that the output U507B pin 7 measures approximately +1 Vdc at one limit and -12 Vdc at the other limit.

Third LO driver amplifier (600 MHz SAWR)

The third LO driver amplifier (Q503) amplifies the 300 MHz from the 600 MHz phase-lock loop to a sufficient level to drive the LO port of the double balanced mixer. During the SIG ID operation, (Option 008 only), diodes CR501 and CR502 turn off the 3rd LO driver amplifier in order to minimize the amount of 300 MHz going to the double-balanced mixer.

Check level at amplifier input (steps 1-6)

1. Press **AUX CTRL, INTERNAL MIXER**. For Option 008, press **SIG ID OFF**.
2. Use an active-probe/spectrum-analyzer combination to confirm the power level of the 300 MHz signal at the following test points:

A15TP602 $\geq +7$ dBm

A15TP504 $\geq +15$ dBm

3. If the signal at A15TP602 is low, but the signal at A15TP504 is correct, press **AUX CTRL, INTERNAL MIXER**. For Option 008, press **SIG ID OFF**.
4. Check that PIN diode switches CR603 and CR605 are reverse biased by approximately +10 Vdc. Refer to function block F of A15 RF schematic.
5. Measure 300 MHz signal at A15TP503 using an active probe/spectrum analyzer combination. If the signal is not approximately +10 dBm, refer to "Unlocked Reference PLL (600 MHz SAWR)" in this chapter.
6. If the level at the TP503 is correct, but signal at TP504 is too low, the fault is probably in the amplifier.

Unlocked Offset Lock Loop (Sampling Oscillator)

Operation

The offset lock loop drives the A15U100 sampler. The offset lock loop sampling oscillator tunes to one of sixteen discrete frequencies between 285 MHz and 297.222 MHz. Refer to A15 schematic. Mixer A15U400 mixes the oscillator output with 300 MHz from the reference PLL, producing a 3 MHz to 15 MHz IF signal. The 3 MHz to 15 MHz signal is compared in the phase/frequency detector with the divided-down 300 MHz from the reference PLL. The phase/frequency detector drives a voltage-to-current diode switch which drives the loop integrator. Loop bandwidth switches vary the loop bandwidth to minimize noise sidebands. The sampling oscillator must produce low noise because the A15U100 sampler multiplies noise by a factor of approximately 24.

[Table 10-7 on page 535](#) lists the prescaler and postscaler divide numbers in the offset loop reference divide chain, for each of the 16 discrete frequencies to which the offset lock loop may be set. It also indicates what the reference frequency into the phase/frequency divide chain is. Refer to function block AN on the RF schematic.

Troubleshooting

Check loop references (steps 1 and 2)

1. Use an active probe and spectrum analyzer to confirm the presence of the following reference to the offset lock loop input:

| | |
|-----------------|-------------------|
| A15TP404 | 300 MHz at +5 dBm |
|-----------------|-------------------|

2. This signal is not correct, refer to "Unlocked Reference PLL" in this chapter.

Check levels into mixer (steps 3-13)

3. Set the HP 8560E/EC to the following settings:

| | |
|------------------------|---------|
| Center frequency | 300 MHz |
| Span | 0 Hz |
| Trigger | SINGLE |

4. Force the PLL to unlock by shorting A15X201 pin 1 to A15X201 pin 5 with a short length of wire. Then connect a dc power supply to A15J200 pin 16.
5. Monitor A15TP201 with an active probe/spectrum analyzer combination. Vary the dc supply until the frequency of the sampling

10. Measure the 296 MHz loop feedback signal at the following test point:

A15TP400 +2 dBm

11. If the feedback signal is not near the indicated power, measure the signals at the following test points on the feedback path. Refer to function blocks AD, AG, and AH of A15 RF schematic.

A15TP200 +4 dBm

A15TP201 +9 dBm

A15TP202 +5.5 dBm

12. Measure the 4 MHz loop-IF signal at the mixer output. The frequency of the IF is the same as the reference frequency and can be found in [Table 10-7 on page 535](#).

A15R447 (end nearest L414) -6 dBm

13. If the IF signal is not near the indicated power, troubleshoot the loop mixer (function block AI).

Check path to phase/frequency detector (steps 14-19)

14. Measure the loop IF signal at the input to the IF amplifier/limiter (function block AK):

A15L428 (end nearest U411) 4 MHz (approximately -6 dBm)

15. Confirm the presence of a 4 MHz square-wave reference frequency signal at U406 pin 3. The square wave is TTL whose peak values should be less than +0.6 V and greater than +2.2 V.

16. Disconnect the jumper from X201 pins 1 and 5. Disconnect the dc power supply which is connected to A15J200 pin 16.

17. Set HP 8560E/EC to the following settings:

Center frequency 300 MHz
Span 0 Hz

18. Use an oscilloscope to confirm the presence of a 4 MHz TTL-level reference frequency signal at U406 pin 11.

19. Connect a short across A15R425. Connect A15U406 pins 3 and 11 together. This puts the same signal on both the phase/frequency detector inputs.

20. Observe the phase/frequency detector outputs, U406 pins 6 and 9, with an oscilloscope. Narrow TTL pulses should be present. Pin 9 is normally low, pulsing high, and pin 6 is normally high, pulsing low.

21. Check the end of L417 (nearest C445) with an oscilloscope. With the oscilloscope input ac-coupled, a triangle waveform approximately 20 mVp-p should be present.
22. Short C441 with a wire jumper. (Connect the jumper from the end of R462 nearest C441 to the end of R460 nearest C443.) This changes the loop integrator into a voltage follower. Refer to function block AB of A15 RF schematic.
23. Check the voltages at the following points:

| | |
|----------------------|--------------------------|
| A15U408 pin 6 | +2.5 Vdc (approximately) |
| A15X201 pin 1 | +2.5 Vdc (approximately) |
24. If the voltages are not correct, suspect A15U408.
25. Remove the jumpers.

Unlocked YTO PLL

Operation

The A11 YTO is locked to two other oscillators: the fractional N oscillator, and the offset PLL sampling oscillator. For LO spans of 2.01 MHz and greater, either the FM or main coil of the YTO is swept directly. For LO spans of 2 MHz and less, the fractional N oscillator is swept. The sampling oscillator remains fixed-tuned during all sweeps.

The output of A11 YTO feeds through the A7 LO distribution amplifier (LODA) to the A15U100 sampler. The offset PLL sampling oscillator, which drives the sampler, oscillates between 285 and 297.222 MHz. The sampler generates harmonics of the sampling oscillator and one of these harmonics mixes with the YTO frequency to generate the sampler IF frequency. As a result, the frequency of the sampler IF is determined by the following equation:

$$F_{IF} = F_{YTO} - (N \times F_{SAMP})$$

Where:

- F_{IF} is the sampler IF
- F_{YTO} is the YTO frequency
- N is the desired sampling oscillator harmonic
- F_{SAMP} is the sampling oscillator frequency

Notice that F_{IF} can be positive or negative depending upon whether the sampling oscillator harmonic used is less than or greater than the YTO frequency. The actual sampler IF is always positive, but the sign is carried along as a "bookkeeping" function which determines which way to sweep the fractional N oscillator (up or down) and what polarity the YTO error voltage should have (positive or negative) to maintain lock.

To check if a negative sampler IF is selected, press **CAL, MORE 1 OF 2, FREQ DIAGNOSE, FRAC N FREQ**. If the fractional N oscillator frequency is positive, the sampler IF is also positive. A negative fractional N frequency indicates that the sampler IF is negative.

Notice that the polarity of the YTO loop error voltage (YTO ERROR) out of the YTO loop phase/frequency detector changes as a function of the polarity of the sampler IF. That is, for positive sampler IFs, an increasing YTO frequency results in an increasing YTO ERROR signal. For negative sampler IFs, an increasing YTO frequency results in a decreasing YTO ERROR signal. This implies that to maintain lock in both cases, the sense of YTO ERROR must be

reversed such that, with a negative sampler IF, an increasing YTO ERROR results in an increasing YTO frequency. This is accomplished with error-sign amplifier, A14U328B. This amplifier can be firmware-controlled to operate as either an inverting or non-inverting amplifier. Digital control line ERRSGN (from A14U313 pin 19) controls the polarity of this amplifier. When ERRSGN is high (positive sampler IF), the amplifier has a positive polarity.

In fractional N spans (LO Spans ≤ 2 MHz), the YTO remains locked to the sweeping fractional N PLL. Thus, the sampler IF must always equal the fractional N oscillator frequency (conditions for lock). Since the YTO must always sweep up in frequency, for negative sampler IFs, the fractional N oscillator must sweep from a higher frequency to a lower frequency. This is necessary since an increasing YTO frequency decreases the sampler IF for negative sampler IFs. The opposite is true for positive sampler IFs, so in these cases, the fractional N oscillator sweeps more conventionally from a lower frequency to a higher frequency.

[Table 10-8 on page 539](#) summarizes the amplifier polarities for the various combinations of sampler IF polarities and LO spans.

The YTO main coil filter is used to improve residual FM in FM and fractional N spans. See function block I of A14 frequency control schematic in the Component-Level Information binder. Transistors Q304 and Q305 switch the filter (capacitor C36 and resistor R48) into the circuit. Transistor Q303 and U333 keep C36 charged during main spans so the frequency does not jump when C36 is switch in.

Table 10-8 Amplifier Polarities

| | | YTO Error Sign Amplifier | ERRSGN (A14U313 pin 19) |
|-------------------------------|---------------------|--------------------------|-------------------------|
| Fractional N Oscillator Swept | Positive Sampler IF | Positive | TTL High |
| | Negative Sampler IF | Negative | TTL Low |
| FM/Main YTO Coils Swept | Positive Sampler IF | Positive | TTL High |
| | Negative Sampler IF | Negative | TTL Low |

Troubleshooting an Unlocked YTO PLL

1. If the YTO PLL is unlocked, error code 301 should be displayed. Place the HP 8560E/EC in zero span. [Figure 10-7 on page 541](#) illustrates the simplified YTO PLL.
2. Move the jumper on A14J23 to connect pins 2 and 3 (TEST position). Refer to [Figure 10-3 on page 515](#) for the location of A14J23. Error code 301 should no longer be displayed. (The YTO PLL feedback path is now open and the YTO error voltage is forced to zero.)
3. On the HP 8560E/EC, press **CAL, MORE 1 OF 2, FREQ DIAGNOSE**, and **LO FREQ**. The displayed LO FREQ is the desired YTO frequency calculated. Record calculated frequency of the YTO below:

YTO Frequency (calculated) = _____ GHz

4. Measure the YTO frequency at the front panel 1ST LO OUTPUT jack and record below:

YTO Frequency (measured) = _____ GHz

Figure 10-7 Troubleshooting an Unlocked YTO PLL

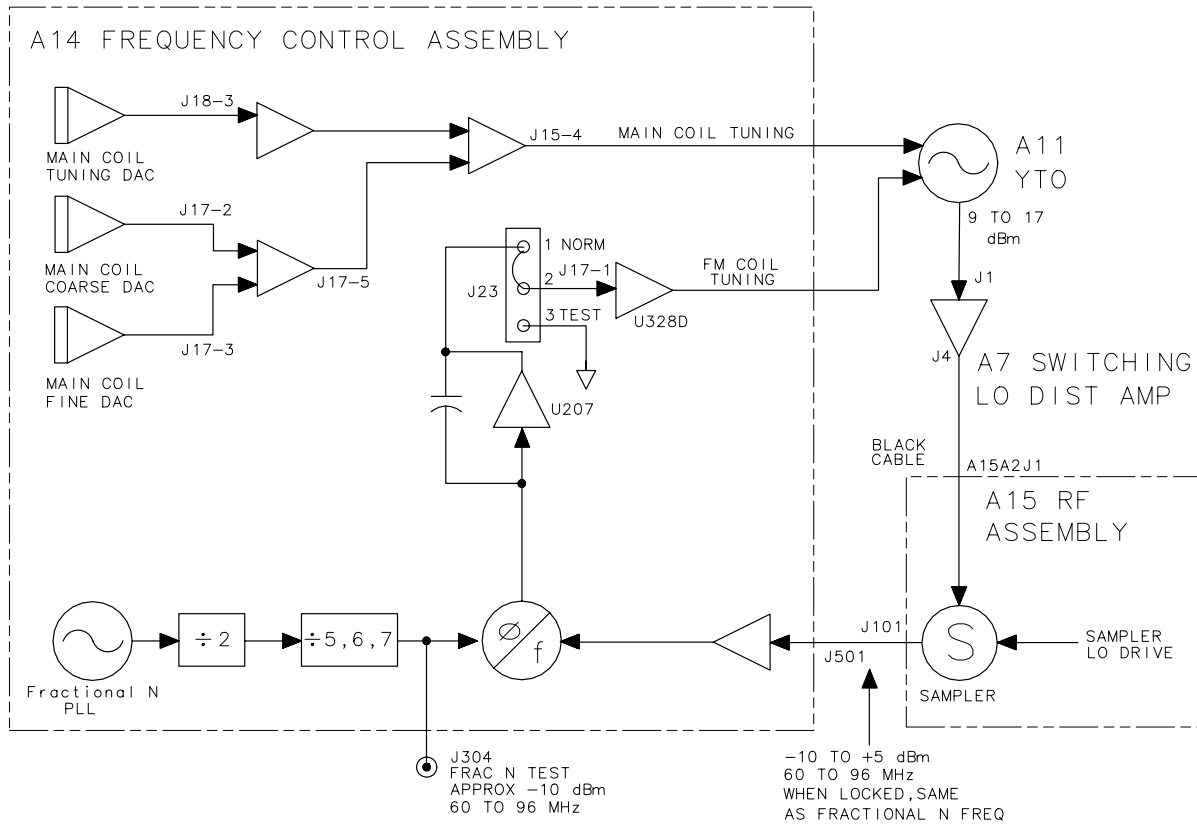

sp131e

- Calculate the YTO frequency error by subtracting the frequency recorded in step 3 from the frequency recorded in step 4. Record the result below:

YTO Frequency Error = _____ MHz

YTO Frequency Error = YTO Frequency (MEASURED) - YTO Frequency (CALCULATED)

- On the HP 8560E/EC, press **MORE 1 OF 2, FREQ DIAGNOSE**, and **FRAC N FREQ**. Record the fractional N frequency below:

Fractional N frequency = _____ MHz

CAUTION

Replacement of the phase/frequency detector chip A14U204 is not recommended. The part is very delicate and requires special tooling to install successfully.

7. If the YTO frequency error recorded in step 5 is greater than 20 MHz, do the following:
 - Check the YTO Adjustments using the TAM or the procedure in Chapter 2.
 - Check the YTO DACs using the procedure in steps 41 through 49 below, or using manual probe troubleshooting with the TAM on A14J17 and A14J18.
 - Refer to steps 9 through 33 below.
8. If the YTO Frequency error recorded in step 5 is less than 20 MHz, do the following:
 - Measure the frequency at A14J304. The frequency should be equal to the frequency recorded in step 6. If not, refer to "Unlocked Fractional N PLL" in this chapter.
 - Measure the input and output levels of the A15U100 sampler. If the sampler appears defective, check the LO drive to the sampler as described in "Sampler and Sampler IF."
 - Refer to steps 34 through 51 below.

Check first LO pretune frequency and amplitude (steps 10-13)

9. The pretuned frequency of the first LO must be sufficiently accurate for the YTO loop to acquire lock. The amplitude of the first LO must be sufficient to drive the A15U100 sampler. Perform the YTO Adjustment procedure, particularly the YTO main coil adjustments. (If available, use a synthesized microwave spectrum analyzer instead of the microwave frequency counter specified in the adjustment procedure.)
10. If the YTO main coil cannot be adjusted, proceed to step 33 to troubleshoot the main coil coarse and fine DACs and main coil tune DAC.
11. The 1ST LO OUTPUT on the front panel should measure between +14.5 and +18.5 dBm in amplitude.
12. If the 1ST LO OUTPUT amplitude is out of the specified range, perform the first LO distribution amplifier adjustment procedure. Refer to Chapter 2.

Check the fractional N oscillator (steps 14-18)

13. Set the HP 8560E/EC to the following settings:

Center frequency 300 MHz
Span 0 Hz

14. Monitor the fractional N PLL output at A14J304 (FRAC N TEST) with a synthesized spectrum analyzer such as an HP 8568A/B or HP 8566A/B. Refer to function block AI of A14 frequency control schematic.

15. The signal at A14J304 (FRAC N TEST) should measure approximately -10 dBm at 66.7 MHz. If the loop is unlocked, the sampler IF frequency can also be seen on A14J304, about 30 dB less than the fractional N signal, when unlocked.

16. If a problem exists only at particular center frequency and span settings, determine the desired fractional N oscillator frequency by pressing **CAL, MORE 1 OF 2, FREQ DIAGNOSE, FRAC N FREQ** and setting the HP 8560E/EC to SINGLE trigger mode.

17. If the fractional N oscillator frequency is not correct, refer to "Unlocked Fractional N PLL" in this chapter.

Check sampler drive output of A7 LODA (steps 19-22)

18. Set jumper A14J23 to the TEST position and set the HP 8560E/EC to the following settings:

Center frequency 2.9 GHz
Span 0 Hz

19. Disconnect cable W34 from A15U100J1.

20. Use a power meter to measure the A7 LODA sampler-drive output at the end of W34. The power should measure greater than -9 dBm.

21. Place jumper A14J23 in the NORMAL position and reconnect W34 to A15U100J1.

Check sampler IF (steps 23-27)

22. Set the HP 8560E/EC to the following settings:

Center frequency 300 MHz
Span 0 Hz

23. Place jumper A14J23 in the TEST position.

24. Disconnect W32 from A15J101. Monitor the sampler IF output (A15J101, SAMPLER IF) with a synthesized spectrum analyzer such as an HP 8568A/B or HP 8566A/B.

25. The sampler IF should measure between 46 MHz and 86 MHz at -15 dBm to $+2$ dBm. If the signal frequency or amplitude is incorrect, refer to "Unlocked Offset PLL" in this chapter.
26. Set jumper A14J23 in the NORMAL position. Reconnect W32 to A15J101.

Check FM loop sense (steps 28-34)

27. Set jumper A14J23 in the TEST position.
28. Set the HP 8560E/EC to the following settings:

Center frequency 300 MHz
Span 0 Hz

29. Connect an RF signal-generator output to A14J501. Set the signal generator to the following settings:

Frequency 56 MHz
Amplitude 0 dBm

30. Monitor A14J17 pin 1 with a DVM or oscilloscope. Connect ground to A14J17 pin 6.
31. As the signal generator frequency is increased to 76 MHz, the voltage at A14J17 pin 1 should change from approximately $+12$ V to -12 V.
32. Set the signal generator to the following settings and repeat step 30.

Frequency 56 MHz
Amplitude -15 dBm

33. If the voltage monitored in step 30 is correct with a 0 dBm output but not with -15 dBm output, suspect the limiting amplifier function block AE.
34. Place jumper A14J23 in the NORMAL position and reconnect W32 to A14J501.

Check YTO FM coil driver and main loop error voltage driver (steps & 35-40)

35. To troubleshoot the YTO FM coil driver, refer to step 6 of "First-LO Span Problems (2.01 MHz to 20 MHz)."
36. Steps 36 through 40 verify that the YTO-loop error voltage is reaching the FM coil. The main loop error voltage driver has a gain of either 1.5 or 15; the spectrum analyzer firmware controls the gain during the locking process. The error voltage is read by the ADC on the A3 interface assembly. A14U326D calibrates out any offsets from true ground. A14U326A inverts the sense of the YTO loop to lock the YTO on lower sampler-sidebands (YTO frequency $<$ (sampler frequency \times sampler harmonic)). The fractional N frequency

indicated in the FREQ DIAGNOSE menu will be negative when locking to lower sidebands. Refer to function blocks E, M, and N of A14 frequency control schematic in the *Component Level Information*.

Set the HP 8560E/EC to the following settings:

Center frequency 300 MHz
Span 0 Hz

37. Remove jumper A14J23 and connect a dc power supply to A14J23 pin 2. Connect ground to A14J23 pin 3. Set the dc power supply to +7.5 Vdc.
38. Verify the nominal test-point voltages listed in [Table 10-9 on page 545](#).
39. Change the input voltage to -7.5 volts and re-verify that the voltages listed in [Table 10-9 on page 545](#) are the same except for a change in polarity.
40. Change the **CENTER FREQ** to 678.8 MHz with the span remaining 0 Hz. This will change the switch setting of U326A and invert the voltages listed in [Table 10-9 on page 545](#).

Table 10-9 Voltages in FM Coil and Main Loop Drivers

| Measurement Points | Voltages |
|--------------------|----------|
| A14U405 pin 6 | +2.8 Vdc |
| A14U322 pin 2 | 0 Vdc |
| A14J17 pin 4 | >+10 Vdc |

Check main coil coarse and fine DACs (steps 41-44)

41. The main coil coarse and fine DACs correct any initial pretune errors in the YTO main coil. The DACs adjust the FM-coil current to zero before any sweep begins. Refer to function block J of A14 frequency control schematic.
42. Set the HP 8560E/EC to the settings listed below. This sets both DACs to 128 (the DAC setting range is 0 to 255).

Center frequency 300 MHz
Span 0 Hz
Trigger SINGLE, EXT
(with no external trigger connected)

43. Press **SAVE, PWR ON STATE** and turn off the spectrum analyzer.
44. Place jumper A14J23 in the TEST position and turn on the spectrum analyzer.

Check main coil tune DAC (steps 45-49)

45. Verify the voltages listed in [Table 10-10 on page 546](#).

Table 10-10 **Main Coil Coarse and Fine DACs Voltages**

| Measurement Points | Voltages |
|--------------------|----------|
| A14J17 pin 2 | -5 Vdc |
| A14J17 pin 3 | -5 Vdc |
| A14J17 pin 5 | +5Vdc |

46. Place jumper A14J23 in the NORMAL position.

47. Set the HP 8560E/EC to the following settings:

Center frequency 300 MHz
Span 0 Hz

48. Place jumper A14J23 in the TEST position.

49. Measure the output of the main coil tune DAC (A14J18 pin 3) with a DVM. Refer to function block E of A14 frequency control schematic.

50. If the HP 8560E/EC center frequency is 300 MHz, the voltage at A14J18 pin 3 should measure $-3.35 \text{ V} \pm 0.25 \text{ V}$. The voltage may also be determined from the following equation:

$$V = -(\text{First LO Frequency} - 2.95 \text{ GHz}) \times 2.654 \text{ V/GHz}$$

51. The voltage at A14U330 pin 2 should measure $-3.4 \text{ V} \pm 0.2 \text{ Vdc}$. This represents a current setting the YTO to approximately 2.95 GHz.

52. Return jumper A14J23 to the NORMAL position.

Unlocked Fractional N PLL

Operation

The fractional N oscillator is used in the HP 8560E/EC as a reference for the first LO phase locked loop. It provides the 1 Hz start-frequency resolution for the first LO, and is the means by which the first LO is swept in LO spans of 2 MHz or less (fractional N spans). The prescaler, fractional N divider, and the postscaler are preset at power-on.

The PLL operates to produce an output frequency in the range of 60 MHz to 96 MHz selectable in 1 Hz increments. The output frequency can be swept (increasing or decreasing) over a selectable 100 Hz to 2 MHz range.

To determine the fractional N frequency for any given center frequency, press **CAL**, **MORE 1 OF 2**, **FREQ DIAGNOSE**, and **FRAC N FREQ**. The FRAC N FREQ frequency displayed is the frequency that will be measured at A14J304 with the HP 8560E/EC in zero span.

Confirming an Unlocked Condition

1. Set the HP 8560E/EC to the following settings:

Center frequency 300 MHz
 Span 0 Hz

2. Connect A14J304 FRAC N TEST to the input of a synthesized spectrum analyzer and view the fractional N PLL output at 66.7 MHz.

NOTE

If a synthesized spectrum analyzer is not available, connect A14J304 to the input of a 20 dB gain amplifier, such as an HP 8447E. Connect the output of the amplifier to the input of a frequency counter.

3. If the fractional N oscillator measures a stable 66.7 MHz, the fractional N PLL is probably locked.
4. Check the two LEDs visible through the shield on A14. If either LED is lit, the fractional N PLL is not locked.
5. If either LED on A14 is lit, and no error message is displayed, check FC MUX A14U305. Refer to function block AH of A14 frequency control schematic.

6. If neither LED is lit, but the output frequency is wrong by more than 1 MHz, check the postscaler, function block AV.
7. Check that the postscaler is dividing properly. The frequency at A14J304 should be equal to the frequency at A14TP4 divided by either 5, 6, or 7. Refer to [Table 10-11 on page 548](#). To keep the divide number at a constant value set the spectrum analyzer to:

Span 0 Hz
 Trigger SINGLE, EXT
 (with no external trigger connected)

Table 10-11 Postscaler Divide Numbers

| Divide Number | D11 | D10 | D9 | Input Range (MHz) (A14J304) | Output Range (MHz) (A14TP4) |
|---------------|-----|-----|----|-----------------------------|-----------------------------|
| 7 | 0 | 0 | 1 | 840 to 973 | 60.0 to 69.5 |
| 6 | 0 | 1 | 0 | 834 to 987.96 | 69.5 to 82.33 |
| 5 | 0 | 1 | 1 | 823.2 to 960 | 82.33 to 96.0 |

If the output frequency is wrong by less than 1 MHz, the phase locked loop is not unlocked but still requires repair. Continue with the "Fractional N Oscillator PLL" section.

Fractional N PLL

The fractional N PLL provides a synthesized frequency in the range of 60 MHz to 96 MHz. The 800 MHz to 1020 MHz voltage controlled oscillator (VCO) in the loop is divided down to lock with the 2.5 MHz reference. Simultaneously, the VCO is divided by two and then by either 5, 6, or 7 to generate the 60 MHz to 96 MHz output.

The prescaler (function block AR) supplies the clock signal for the fractional divider and is required for the fractional divider to operate. At the start of a fractional N sweep, the fractional divider is set to a value for the start frequency and a sweep rate. It then sweeps for as long as HSCAN is high. Use the following procedure to troubleshoot unlocked loop problems or problems of locking to the wrong frequency (by less than 1 MHz):

1. Check the two LEDs on A14 frequency control assembly. If either LED is lit, the fractional N phase locked loop is not locked.
2. The 10 MHz reference is required for fractional N operation. It is divided by four to 2.5 MHz in the reference divider circuitry, block AN. It is used to lock the divided voltage controlled oscillator (VCO) frequency. Check that the 10 MHz reference is present at A14J301. The 10 MHz reference is derived from the 600 MHz reference on the

- A15 RF assembly.
3. Change the spectrum analyzer from the fractional N span to 0 Hz.
 4. Check the frequency at A14TP1. It should equal the value found by pressing **CAL, MORE 1 OF 2, FREQ DIAGNOSE, and RAW OSC FREQ.**
 5. Check the tune voltage at the ungrounded end of C135.
 6. Look up the expected problem area in [Table 10-12 on page 549](#) with the information from steps 4 and 5. Go to the appropriate troubleshooting steps.

Table 10-12 Unlocked Fractional N Troubleshooting Areas (08560-60069 and Above)

| Measured VCO Frequency Relative to Expected Value | Tune Voltage | | | | |
|---|----------------|-----------------------|------------------------|-----------------------|----------------------|
| | Less than -4 V | About -3.3 V | Between -2 V and +10 V | About +11 V | Greater than +12.5 V |
| Measured > expected | VCO clamp | VCO | Divider or integrator | Divider or integrator | VCO clamp |
| Measured < expected | VCO clamp | Divider or integrator | Divider or integrator | VCO | VCO clamp |
| Measured, not oscillating | VCO clamp | VCO | VCO | VCO | VCO clamp |

Table 10-13 Unlocked Fractional N Troubleshooting Areas (08560-60062 and below)

| Measured VCO Frequency Relative to Expected Value | Tune Voltage | | | | |
|---|-------------------|-----------------------|-----------------------|-----------------------|----------------------|
| | Less than -12.5 V | About -11 V | Between ±10 V | About +11 V | Greater than +12.5 V |
| Measured > expected | VCO clamp | VCO | Divider or integrator | Divider or integrator | VCO clamp |
| Measured < expected | VCO clamp | Divider or integrator | Divider or integrator | VCO | VCO clamp |
| Measured, not oscillating | VCO clamp | VCO | VCO | VCO | VCO clamp |

7. VCO clamp troubleshooting: Q131, Q132 and the associated components should limit the tune voltage at R240 to about -3.3 V to $+11\text{ V}$ ($\pm 11\text{ V}$ for 08560-60062 and below). If the integrator (its output voltage is on TP13) tries to produce a voltage outside this range, excess current is shunted through CR131 and Q131 for positive excursions or CR132 and Q132 for negative excursions. The base of Q131 should be at about $+9.60\text{ V}$, and the base of Q132 should be at about -2.09 V for proper operation. If troubleshooting an earlier A14 frequency control assembly (08560-60062 and below), the bases of Q131 and Q132 should be at about $\pm 9.6\text{ V}$ for proper operation.
8. VCO troubleshooting: Check the dc biases in the VCO function block. The bias voltages, for some points in the VCO, are indicated in [Figure 10-8 on page 551](#) (or Figure 10-8a for earlier instruments).

Figure 10-8 VCO Bias Voltages for A14 Assemblies 08560-60069 and Above

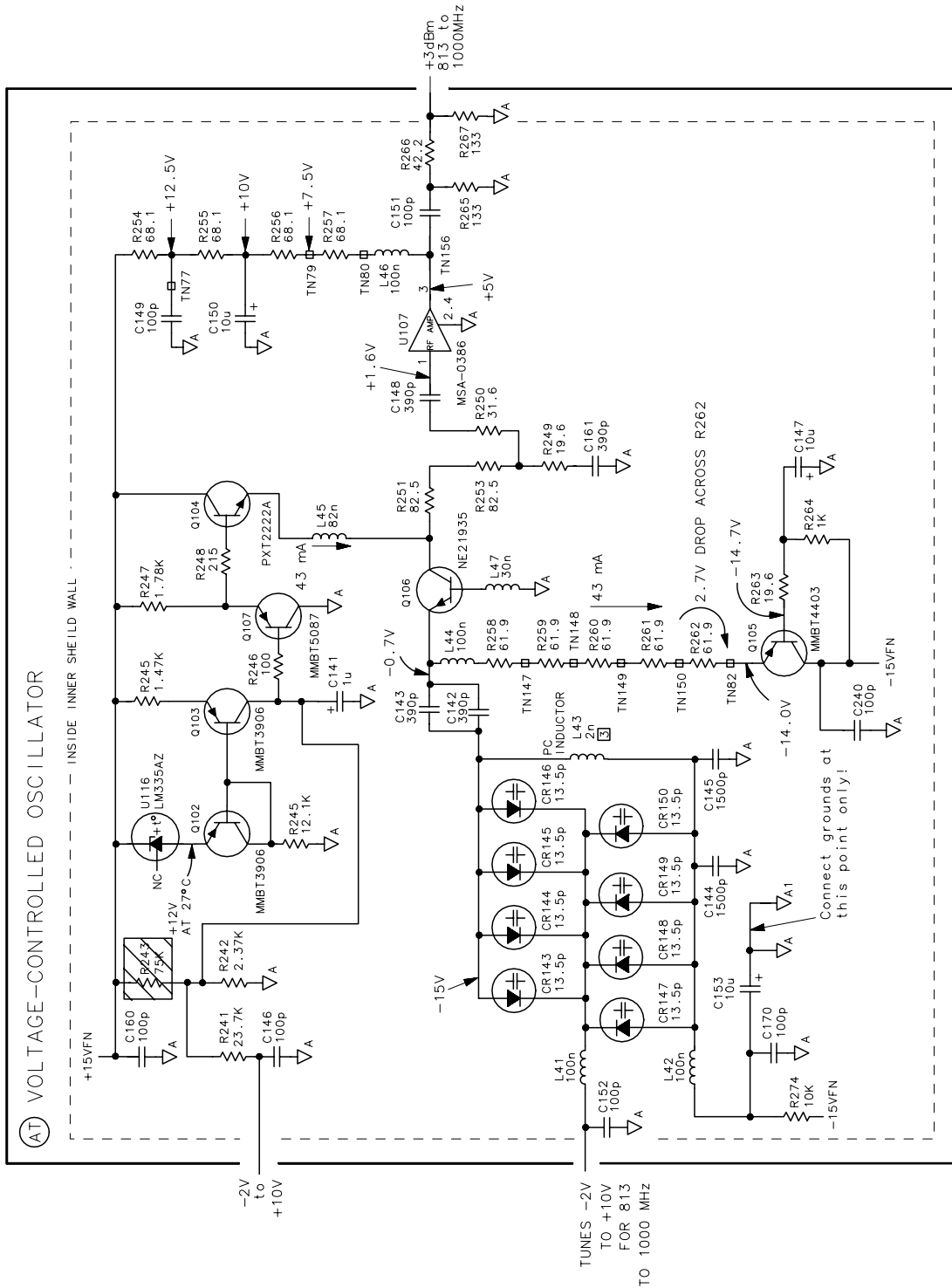

sz 139e

Figure 10-8a VCO Bias Voltages for A14 boards(08560-60062 and below)

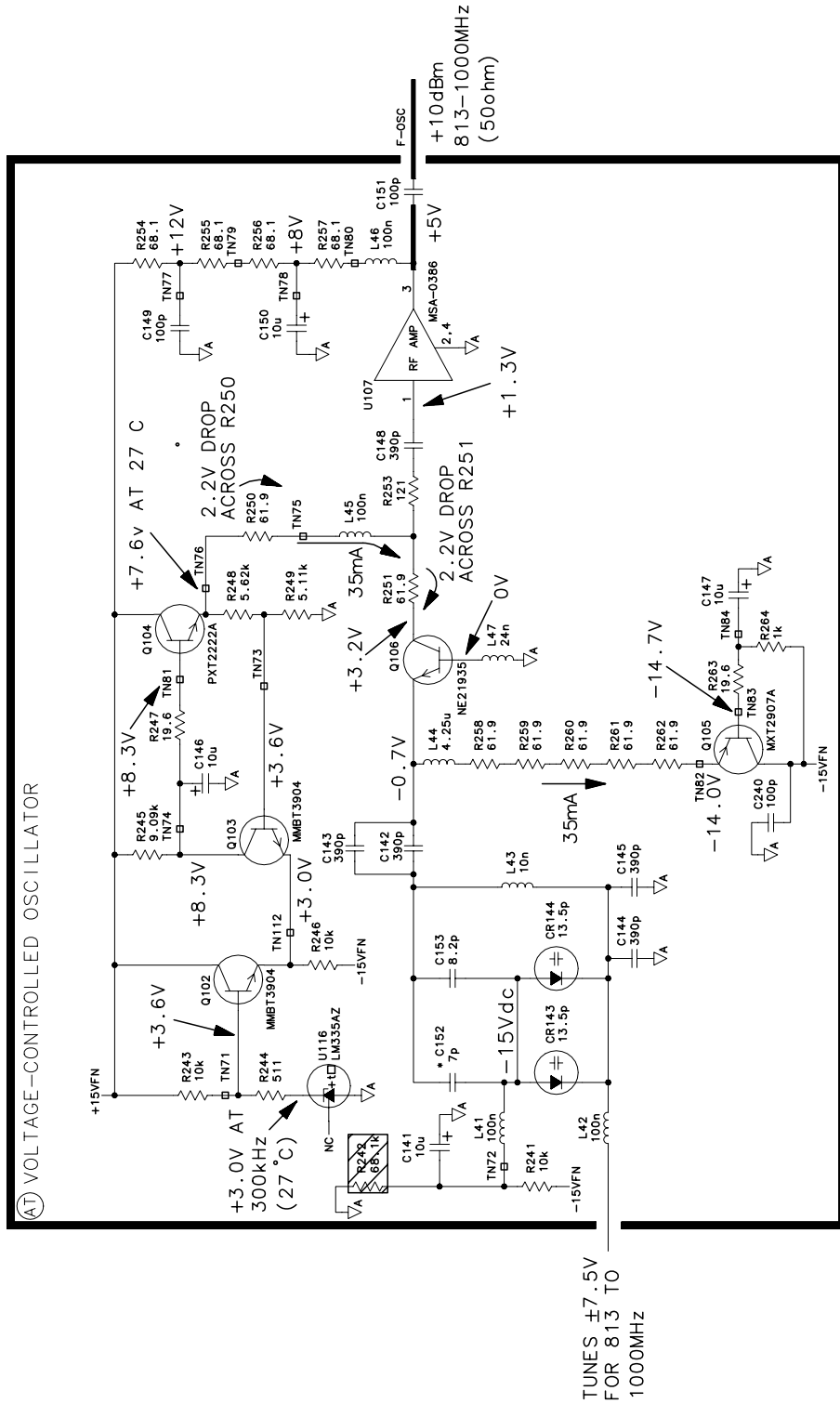

sp140e

- Divider and integrator troubleshooting: Measure the frequency of the pulses at TP6 in block AO. Look up the expected problem area in [Table 10-14 on page 553](#) and go to the appropriate troubleshooting

steps.

Table 10-14 Divider and Integrator Troubleshooting

| Measured VCO Frequency Relative to Expected Value | TP6 Frequency | | | |
|---|---------------|-------------------|----------|-------------------|
| | zero | <2.5 MHz | 2.5 MHz | >2.5 MHz |
| Measured > expected | Dividers | Dividers | Dividers | Det or integrator |
| Measured < expected | Both | Det or integrator | Dividers | Dividers |

10.Divider troubleshooting:

- a. Check the frequency at A14TP2. It should be equal to the frequency at A14TP1 divided by two.
- b. The signal at A14TP3 should be greater than -14 dBm.
- c. Use an analog oscilloscope to view the signal at A14TP5. Adjust the scope triggering to view the divide-by-16 signal. The frequency at this point will be varying as the prescaler changes its divide number to either 16, 17, 20, or 21. The prescaler uses 16 as the divide number most frequently. The frequency displayed on the oscilloscope should equal the frequency from TP2 divided by 16.
- d. Use an oscilloscope to view the signal at pin 8 of U112. Its average frequency should be given by:

$$f = f(A14TP5) \times 80 \text{ MHz/RAW OSC FREQ}$$
 where: f(A14TP5) is the frequency measured at TP5, and RAW OSC FREQ comes from step 4 (A14TP1).
 If the frequency is in error, the fractional divider, block AS, is not functioning. Check that FRAC N RUN on U113 pin 39 is high.
- e. Use an oscilloscope to verify that the signals at N_in (U112 pin 8) and N_out (TP6) are identical except for a sub-microsecond delay.

11.Detector and integrator troubleshooting:

- a. Check the phase detector output on TP11 in block AO. If F_ref is higher in frequency than TP6 (relocked VCO/N), then the average voltage at TP11 should be positive by 0.05 V to 10 V. If F_ref is lower, TP11 should be -0.05 V to -10 V.
- b. The polarity of the output of the loop gain (block AP, TP12) should be the same as the polarity of the input (TP11).

- c. The integrator op amp (U106) output (TP13) should try to go very positive (about +12 V) if its average input (TP12) is positive. If its average input is negative, it should try to go very negative (about -4 V). If its average input is zero and it is functioning correctly, it may take on any output voltage between -4 V and +12 V (between -12 V and +12 V for 08560-60062 and below).

Frequency Span Accuracy Problems

The HP 8560E/EC employs lock-and-roll tuning to sweep the first LO for spans greater than 2.0 MHz. The first LO is locked to the start frequency immediately after the previous sweep has been completed. The first LO is then unlocked, and, when a trigger signal is detected, the first LO sweeps (rolls).

When there is a considerable delay between the end of one sweep and the beginning of the next, the actual first LO start frequency may differ from the locked start frequency. This start frequency drift will be most noticeable in a 2.01 MHz LO span (the narrowest FM coil span). This drift is not noticeable in either free run or line trigger modes. The sweep is generated by different oscillators in the synthesizer section depending on the desired first-LO span (due to harmonic mixing, this is not necessarily the same as the span setting of the spectrum analyzer). Refer to [Table 10-15 on page 555](#) for a listing of sweep-signal destinations versus First LO spans. Sweeping the fractional N oscillator results in sweeping the YTO FM coil. There is a one-to-one relationship between the fractional N oscillator frequency span and the first-LO span. The fractional N oscillator sweep is generated digitally. The oscillator is always synthesized, rather than employing lock and roll tuning.

Table 10-15 Sweep Signal Destination versus Span

| First LO Span | Sweep Signal Destination |
|--------------------|--|
| >20 MHz | A11 YTO main coil |
| 2.01 MHz to 20 MHz | A11 YTO FM coil |
| ≤2 MHz | None Fractional N oscillator sweeps without a sweep ramp signal. |

Determining the First LO Span

The first-LO span depends on the spectrum analyzer harmonic-mixing number. Use the following steps to determine the span of the first LO:

1. Read the span setting displayed on the HP 8560E/EC.
2. Determine the harmonic-mixing number from the information in [Table 10-16 on page 556](#).

Table 10-16 Harmonic Mixing Number versus Center Frequency

| Center Frequency | Harmonic Mixing Number |
|-------------------|--|
| 1 kHz to 2.9 GHz | 1 |
| 18 GHz to 325 GHz | 6 through 54 depending upon lock harmonic selected |

3. Use the following equation to determine the first LO span used.

$$\text{First LO Span} = \frac{\text{Display Span Setting}}{\text{Current Band Harmonic Mixing Number}}$$

4. Refer to [Table 10-15 on page 555](#) to determine the circuit associated with the span.

Confirming Span Problems

- If all first LO spans or only first LO spans of 2.01 MHz or greater are affected, perform the YTO Adjustment procedure in Chapter 2.
 - On the HP 8560E/EC press **CAL, REALIGN LO &IF**, and retest all spans.
 - If the YTO adjustment has sufficient range and only LO spans of 2.01 MHz or greater are faulty, test YTO linearity by performing step c.
 - Test the span in question at different center frequencies in the same band. If the span accuracy changes significantly (2% or more), suspect the A11 YTO.
- If first LO spans of 2 MHz or less only are faulty, suspect the A14 fractional N PLL.
- If there are several spans in the main coil and FM coil ranges affected, suspect the A14 span attenuator.

YTO Main Coil Span Problems (LO spans >20 MHz)

For YTO main coil spans, the YTO is locked at the beginning of the sweep and the sweep ramp is summed into the main coil tune driver.

- Perform the YTO adjustment procedure in Chapter 2. If the YTO adjustments cannot be performed, continue with step 2.
- Set the HP 8560E/EC to the following settings:

Start frequency 10 MHz
 Stop frequency 2.9 GHz

3. Verify that a -1.2 V to -4.8 V ramp (approximately) is present at A14U331 pin 2.

If this ramp is not present, troubleshoot the main/FM sweep switch. See function block H of A14 frequency control schematic (sheet 2 of 5).

4. Measure the output of the main coil tune DAC at A14J18 pin 3. At the frequency settings of step 2, this should be -2.48 V .

If the voltage is not -2.48 V , troubleshoot the main coil tune DAC. See function block E of A14 frequency control schematic (sheet 2 of 5).

YTO FM Coil Span Problems (LO spans 2.01 MHz to 20 MHz)

In YTO FM coil spans, the YTO loop is locked and then opened while the sweep ramp is summed into the FM coil. The FM coil sensitivity is corrected by changing the sensitivity of the FM coil driver.

1. Perform the YTO Adjustment procedure in Chapter 2. If the YTO adjustments cannot be performed, continue with this procedure.

2. Set the HP 8560E/EC to the following settings:

| | |
|------------------------|---------|
| Center frequency | 300 MHz |
| Span | 20 MHz |
| Sweep time | 50 ms |

3. Check for the presence of a 0 V to -10 V sweep ramp at A14J15 pin 14 (input to the main/FM sweep switch). Refer to function block H of A14 frequency control schematic (sheet 2 of 5).
4. Check for the presence of a 0 V to $+5\text{ V}$ sweep ramp at A14U405 pin 6 (YTO FM coil driver). Refer to function block M of A14 frequency control schematic (sheet 2 of 5).
5. Check the state of the Main/FM sweep switches as indicated in [Table 10-17 on page 558](#).
6. The rest of the procedure troubleshoots the YTO FM coil driver. Refer to function block M of A14 frequency control schematic (sheet 2 of 5).

Table 10-17 Settings of Sweep Switches

| Switch | Switch State | Switch Control Line (Pin #) | Control Line State (TTL) |
|--------|--------------|-----------------------------|--------------------------|
| U318A | Closed | 1 | High |
| U318B | Open | 16 | High |
| U318C | Closed | 9 | Low |
| U318D | Open | 8 | Low |

7. Set the HP 8560E/EC to the following settings:

Center frequency 300 MHz
 Span 0 Hz
 Trigger SINGLE, EXT

- a. On the HP 8560E/EC, press **SAVE, SAVE STATE, STATE 0**.
- b. Remove jumper A14J23 and connect a dc voltage source to A14J23 pin 2. Connect the voltage source ground to A14J23 pin 3.
- c. Connect a microwave frequency counter or spectrum analyzer to the HP 8560E/EC 1ST LO OUTPUT (front panel output).
- d. Set the dc voltage source output for 0 Vdc and note the 1st LO frequency.
- e. Set the dc voltage source output for +10 Vdc. The first LO frequency should momentarily increase approximately +15.6 MHz.
- f. The voltage at A14U332 pin 2 should be approximately 19% of the voltage at A14J23 pin 2.
- g. If the first LO frequency did not change in step e, turn off the HP 8560E/EC **LINE** switch and disconnect W10 from A14J3.
- h. Place a jumper between A14J3 pins 9 and 10. Place a 50 Ω , 3 watt resistor across A14J3 pins 5 and 6 (resistor, HP part number 0811-1086). Set the **LINE** switch on.
- i. On the HP 8560E/EC, press **RECALL, STATE, STATE 0**.
- j. The voltage at A14U332 pin 2 should be approximately 19% of the voltage at A14J23 pin 2.
- k. If the voltage at U332 pin 2 is correct with A14J3 pins 9 and 10 shorted, but was incorrect with W10 connected, the YTO FM coil is probably open; replace the A11 YTO.
- l. Replace jumper A14J23. Remove the jumper and resistor from A14J3. Reconnect W10 to A14J3.

Fractional N Span Problems (LO spans ≤ 2 MHz)

If the fractional N spans are inaccurate or nonexistent, but the fractional N PLL is locked to the correct frequency and other spans are correct, there may be a problem with the HSCAN signal. Check that HSCAN is present at the fractional divider, U113 pin 41 in function block AS. HSCAN comes from the A3 interface assembly and goes to the sweep generator circuitry in function block A and to Fractional N.

First LO Span Problems (All Spans)

1. Set the HP 8560E/EC to the following settings:

| | |
|------------------------|---------|
| Center frequency | 300 MHz |
| Span | 2 MHz |
| Resolution BW | 1 MHz |
| Video BW | 1 MHz |
| Sweep time | 50 ms |

2. Check that there is 0 V to +10 V ramp of 50 ms duration at A14J15 pin 15.
3. If a scan ramp is not present, refer to "Sweep Generator" in this chapter.
4. If there is a 0 to -10 V ramp at A14J15 pin 14, the fault is probably in the Main/FM sweep switch. See function block H of A14 frequency control schematic.
5. Check that there is a 0 V to +10 V ramp at U325 pin 1. The spectrum analyzer ADC obtains information about the sweep from this node.

Check span attenuator (steps 6-13)

1. Continue with step 7 to check the span attenuator. See function block L of A14 frequency control schematic (sheet 2 of 5).
2. With the spectrum analyzer set to the settings in step 1, monitor A14U323 pin 6 with an oscilloscope. A 0 V to -10 V ramp should be present.
3. Change the spectrum analyzer span to 10 MHz and check for a 0 V to -5 V ramp at U323 pin 6.
4. Change the spectrum analyzer span to 2.01 MHz and check for a 0 V to -1 V ramp at U323 pin 6.

5. Set the spectrum analyzer to the following settings:

Start frequency 10 MHz
Stop frequency 2.9 GHz
Sweep time 80 ms

6. Monitor A14J15 pin 14 for a 0 V to -7.4 V ramp. Switches U317A, U317B, and U317D should be open and U317C should be closed.

7. Change the spectrum analyzer SPAN to 365 MHz and check for a 0 to -936 mV ramp at A14J15 pin 14. Switches U317A, B, and C should be open and U317D closed.

8. Change the spectrum analyzer SPAN to 36.5 MHz and check for a 0 to -93.6 mV ramp at A14J15 pin 14. Switches U317B, C, and D should be open and U317A closed.

Phase Noise Problems

System phase noise can be a result of noise generated in many different areas of the spectrum analyzer. When the spectrum analyzer is functioning correctly, the noise can be observed as a function of the distance away (the offset) from the carrier frequency. The major contributor to system noise can be characterized as coming from specific circuit areas depending upon the offset frequency.

Some very general recommendations can be made for identifying which circuitry is the cause of the noise at certain offsets. The recommendations below apply with a center frequency of 1 GHz.

Table 10-18 Settings of Sweep Switches

| Carrier Frequency Offset | Major Contributor (when working correctly) |
|--------------------------|--|
| 100 Hz | Reference (OCXO or TCXO) |
| 1 kHz | 100 MHz (or 600 MHz) reference PLL |
| 3 kHz | Fractional N PLL |
| 10 kHz to 150 kHz | Offset lock loop or YTO loop |
| >150 kHz | YTO |

Phase Noise in Locked versus Lock-and-Roll Spans

Input a signal to the spectrum analyzer. Set the center frequency to the input signal frequency, set the span to 2 MHz, and plot the display. This plots the system noise for a locked sweep. Plot the display again with a span of 2.01 MHz (lock and roll sweep). The crossover point of the noise floor of the two plots is typically at an offset of about 50 kHz, for a functioning instrument.

If the crossover point is shifted out to a higher offset frequency, suspect the YTO loop circuitry.

If the crossover point is shifted in to a lower offset frequency, suspect the offset or fractional N loop circuitry.

Reference versus Reference PLL Phase Noise

If the problem seems to be in the frequency reference or reference PLL circuitry, measure the noise with internal and external references. If there is no difference, suspect the circuitry associated with the 100 MHz VCXO (or the SAWR A15U701 on earlier A15 RF assemblies). If there is a difference, look at 10 MHz distribution, OCXO, or TCXO.

Fractional N versus Offset PLL or YTO PLL Phase Noise

If the spectrum analyzer has excessive noise at >1 kHz offset, measure the noise with center frequencies of 100 MHz and 2.5 GHz.

If the measurements are equal, suspect the fractional N circuitry and the YTO loop circuitry on the A14 frequency control assembly.

If the measurements differ by 2 dB to 5 dB, with the 2.5 GHz measurement at a higher noise level, suspect the offset lock loop circuitry.

Fractional N PLL Phase Noise (08560-60062 and below only)

Check the noise on the 5 V regulators on A14, particularly the regulator in the reference divider circuitry A14U121. Refer to function block AN on the A14 frequency control assembly schematic.

- The noise level of the voltage regulator should be <1 mV. The typical noise level is 40 μ V RMS between 10 Hz and 100 kHz.
- A coaxial probe with very little unshielded tip area should be used to avoid picking up radiated 60 Hz. Check that your measurement is valid by probing ground on the circuit and verifying that the measured value is well under the 1 mV threshold that indicates a defective regulator.

There can also be phase noise problems if the loop gain is incorrect. See function block AP for loop gain troubleshooting information.

Sampler and Sampler IF

The A15U100 sampler creates and mixes harmonics of the sampling oscillator with the first LO. The resulting sampler IF (60 MHz to 96 MHz) is used to phase-lock the YTO. The sampler IF filters unwanted products from the output of A15U100 and amplifies the IF to a level sufficient to drive the YTO loop. When the IF is less than 87.14 MHz, PIN diodes switch a 120 MHz low pass filter in the sampler IF section.

1. Set HP 8560E/EC to the following settings:

Center frequency 300 MHz
 Span 0 Hz

2. Disconnect W32 from A15J101.
3. Connect the input of a power splitter to A15J101. Connect W32 to one of the splitter outputs. Connect the other splitter output to the input of another spectrum analyzer.
4. If a 66.7 MHz signal, greater than -15 dBm, is not displayed on the other spectrum analyzer, set a microwave source to the following settings:

Frequency 4.2107 GHz
 Amplitude -5 dBm

5. Connect the microwave source to A15U100J1. A 66.7 MHz signal at approximately 0 dBm should be displayed on the other spectrum analyzer.
6. Use an active probe/spectrum analyzer combination to measure the signal at the following test points:

| | |
|-----------------|--------------------|
| A15TP101 | 66.7 MHz, -8 dBm |
| A15TP201 | 296 MHz, $+9$ dBm |

7. If a correct signal is seen at A15TP201 but the signal at A15TP101 is wrong, proceed as follows:

- Use an oscilloscope to measure the signals at the following test points:

A15J400 pin 1 $+0.8$ Vdc to $+1.6$ Vdc (≤ 0.5 Vp-p variation)
A15J400 pin 3 -0.8 Vdc to -1.6 Vdc (≤ 0.5 Vp-p variation)

- If these levels are wrong, perform the "Power and Sampler Match Adjustments" in the sampler oscillator adjustment procedure. Refer to Chapter 2.
 - If adjusting the sampler match does not bring the signal at A15TP101 within specification when the signal at A15TP201 is correct, the A15U100 sampler is defective.
8. The sampler IF signal at A15J101 is 60 MHz to 96 MHz at -10 dBm to $+5$ dBm. If the signal at A15TP101 is correct, but the signal at A15J101 is wrong, the fault lies in the sampler IF circuitry. Continue with the following steps.
 9. Set the HP 8560E/EC to the following settings:
Center frequency 300 MHz
Span 0 Hz
 10. Set a microwave source to the following settings:
Frequency 4.2107 GHz
Amplitude -5 dBm
 11. Connect the microwave source to A15U100J1.
 12. Measure the signal at U103 pin 1 using an active probe/spectrum analyzer combination.
 13. If a 94.7 MHz signal, approximately -14 dBm, is present, but the signal at A15J101 is low, suspect U103.
 14. When U104 pin 3 is at TTL low, U104 pin 6 should be near -15 Vdc and PIN diodes CR101, CR102, and CR103 should be reverse-biased.
 15. Set HP 8560E/EC to the following settings:
Center frequency 89.3 MHz
Span 0 Hz
 16. Check that U104 pin 3 is at a TTL high and U104 pin 6 is greater than $+7$ V. PIN diodes CR101, CR102, and CR103 should all be turned on with about 7 mA of forward current.
 17. Disconnect the power splitter and reconnect W32 to A15J101.

Sweep Generator Circuit (for Spectrum Analyzers with 100 s max. Sweep Time)

The sweep generator operates by feeding a constant current from DAC U307 into an integrator, U320B. See function block A of A14 frequency control schematic. This current is scaled by resistors R20 through R24 and U312B/C/D. See [Figure 10-9 on page 566](#). The capacitors used in the integrator depend on the sweeptime range; smaller-value capacitors provide faster sweep times.

The integration is initiated by HSCAN going high. This opens U312A which places the output of U320A near -15 Vdc, turning CR6 off and allowing the output of integrator U320B to ramp from 0 V to $+10$ Vdc. The analyzer ADC monitors the scan ramp at U325A pin 1 via the scan ramp attenuator U320B pin 7. When the ramp reaches $+10$ V (for single-band sweeps), HSCAN is brought low and the integration ends. During normal non-fast-zero spans (sweep times >30 ms), comparators U319A and B are high. This turns off diodes CR1, CR2 and turns on transistors Q1 and Q2. The integrating current has a maximum value of $236 \mu\text{A}$.

During retrace, HSCAN is low, closing U306B and U312A. See [Figure 10-10 on page 567](#). The output of U320A tries to go high, turning CR6 on and sourcing current through R26. This current discharges the capacitors in the integrator, forcing U320B pin 7 toward 0 Vdc. Ultimately, the output of U320B will be brought and held to 0 V by U320A supplying a current equal to that which is sunk by the current source. For more information, refer to "First-LO Span Problems (Multiband Sweeps)" in this chapter.

Figure 10-9 **Simplified Sweep Generator**

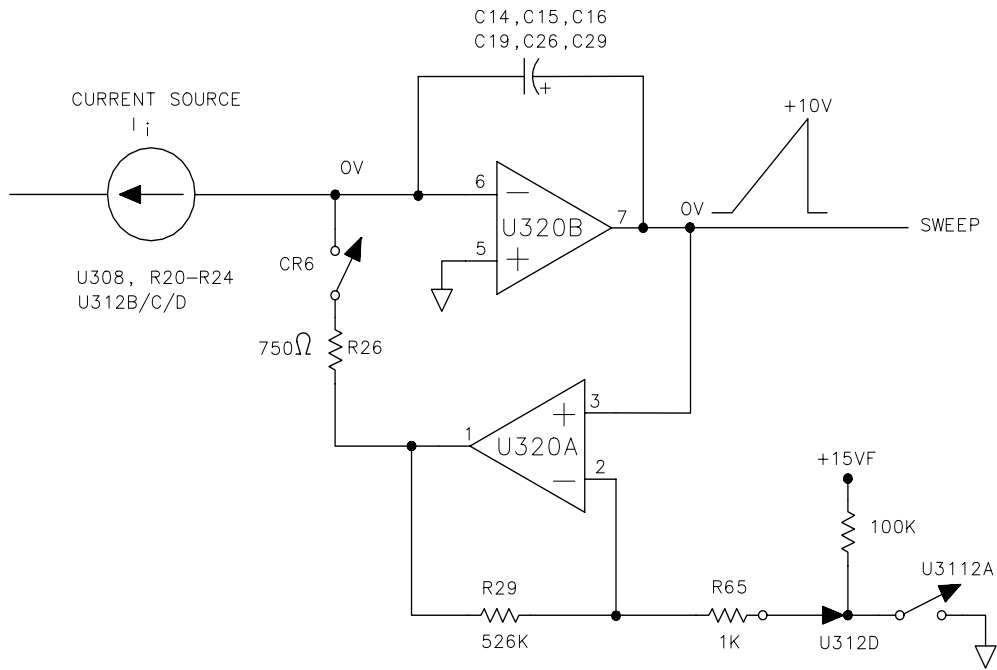

sp132e

Figure 10-10 Simplified Sweep Generator during Retrace

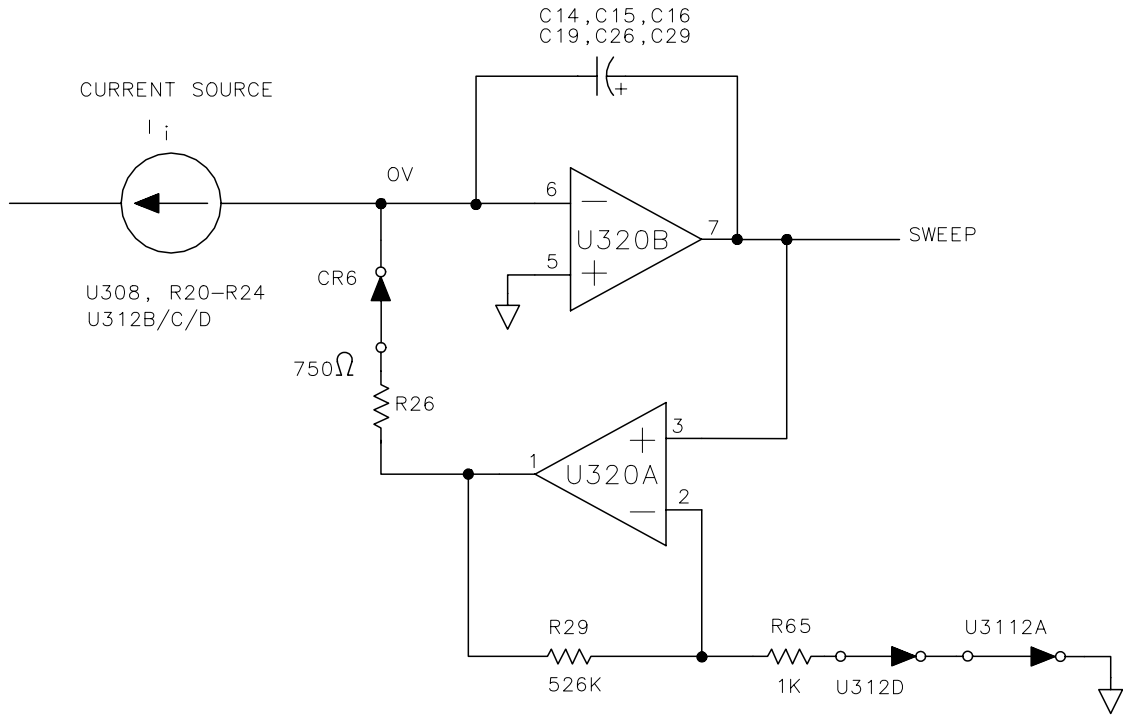

Sweep Generator Circuit (for Spectrum Analyzers with 2000 s max. Sweep Time)

The sweep generator circuitry generates a ramp from 0 to 10 volts during the sweep time. The available sweep times range from 50 μ s to 2,000 seconds. The sweep times are generated in two different ranges, a 50 μ s to 30 ms range and a 50 ms to 2,000 second range. The 50 μ s to 30 ms range is only needed for analog zero span sweeps.

The sweep generator is controlled with an 8-bit latch and the control signal HSCAN. The latch, U308, controls the sweep rate. HSCAN determines when to reset the scan ramp and when to let it sweep.

Operation of the 50 ms to 2,000 second range will be described using a 50 ms sweep time as the example. For a 50 ms sweep time, Q1 shorts out C16. The D to A converter U307, has zero output current. U334A is a buffer with zero offset, because there is no current coming out of U307. The buffering of U334 makes the base-emitter voltages on Q3A and Q3B the same. These two transistors are matched, so their collector currents should be identical when their base-emitter voltages are identical. The emitter current of Q3B is 200 μ A, therefore the emitter current of Q3A is 200 μ A and the sweep ramp is generated by C14. The sweep time is given by the formula:

$$\text{sweeptime} = \text{capacitance}(C14) \frac{\Delta V}{\text{current}}$$

Where ΔV is equal to 10 Volts.

With a capacitance of 1 μ F and a current of 200 μ A, the sweep time should be 50 ms. The DAC setting is increased for longer sweep times. This increases the current sunk by the DAC output U307 pin 4, which increases the emitter voltage on Q3A, decreasing the base-emitter voltage drop. Q3A acts as an exponentiator and reduces its collector current, creating a slower sweep ramp.

For the shorter sweep times, 50 μ s to 30 ms, Q1 is opened putting C16 in series with C14. This changes the effective capacitance from 1 μ F to 1,000 pF, or a reduction of 1,000 to 1.

The HSCAN signal uses Q2 to reset the ramp. Q2 shorts the integrator and sets its output nominally to ground.

Check the sweep generator circuit

1. Press **PRESET** and set the spectrum analyzer to the following settings:

Center frequency 300 MHz
 Span 100 MHz
 Sweep time 50 ms

2. Using an oscilloscope, check that the sweep ramp at A14U320 pin 6

sweeps linearly from 0 to +10 Volts in 50 ms, then resets to 0 Volts.

3. Change the sweep time to 10 seconds and check that the sweep ramp (U320 pin 6) sweeps linearly from 0 to +10 Volts in 10 seconds, then resets to 0 Volts.

4. Change the spectrum analyzer settings as follows:

Span 0 Hz
Sweep time 10 ms

5. Check that the ramp (U320 pin 6) sweeps linearly from 0 to +10 Volts in 10 ms, then resets to 0 Volts.

6. If the any of the sweep times were not within specification or the sweep ramp appeared to be non-linear in the preceding steps, proceed with the following steps:

7. Connect the negative lead of a voltmeter to A14Q3 pin 8 and connect the positive lead to A14U312 pin 1 to check the temperature sensor (U312).

8. The voltage at pin 1 should be $10 \text{ mV}/^{\circ}\text{C}$ times the temperature of the A14 frequency control assembly. (For example, if the ambient temperature is approximately 20°C , and the A14 frequency control assembly is 10°C warmer, the actual temperature of the A14 assembly is 30°C and U312 pin 1 should measure 300 mV.)

9. To check the temperature-dependent offset voltage generator, connect the positive lead of the voltmeter A14Q3 pin 6. The voltmeter should read $-600 \text{ mV} \pm 150 \text{ mV}$.

10. To check the DAC buffer, A14U334A, connect the positive lead of the voltmeter to A14U334 pin 2. The voltmeter should read the same voltage measured at A14Q3 pin 6, within 2 mV. (The same voltage should be present at U334 pin 3.)

11. To check the buffered DAC, press **PRESET** and set the spectrum analyzer as follows:

Center frequency 300 MHz
Span 100 MHz
Sweep time 50 ms

12. Connect the positive lead of the voltmeter to A14U334 pin 1. The voltmeter should read the same voltage measured at U334 pin 2, within 2 mV.

13. Change the spectrum analyzer sweep time to 2000 seconds. The voltage at A14U334 pin 1 should increase by $275 \text{ mV} \pm 20 \text{ mV}$ (compared to the voltage measured in step 12).

Figure 10-11 Simplified Synthesizer Section

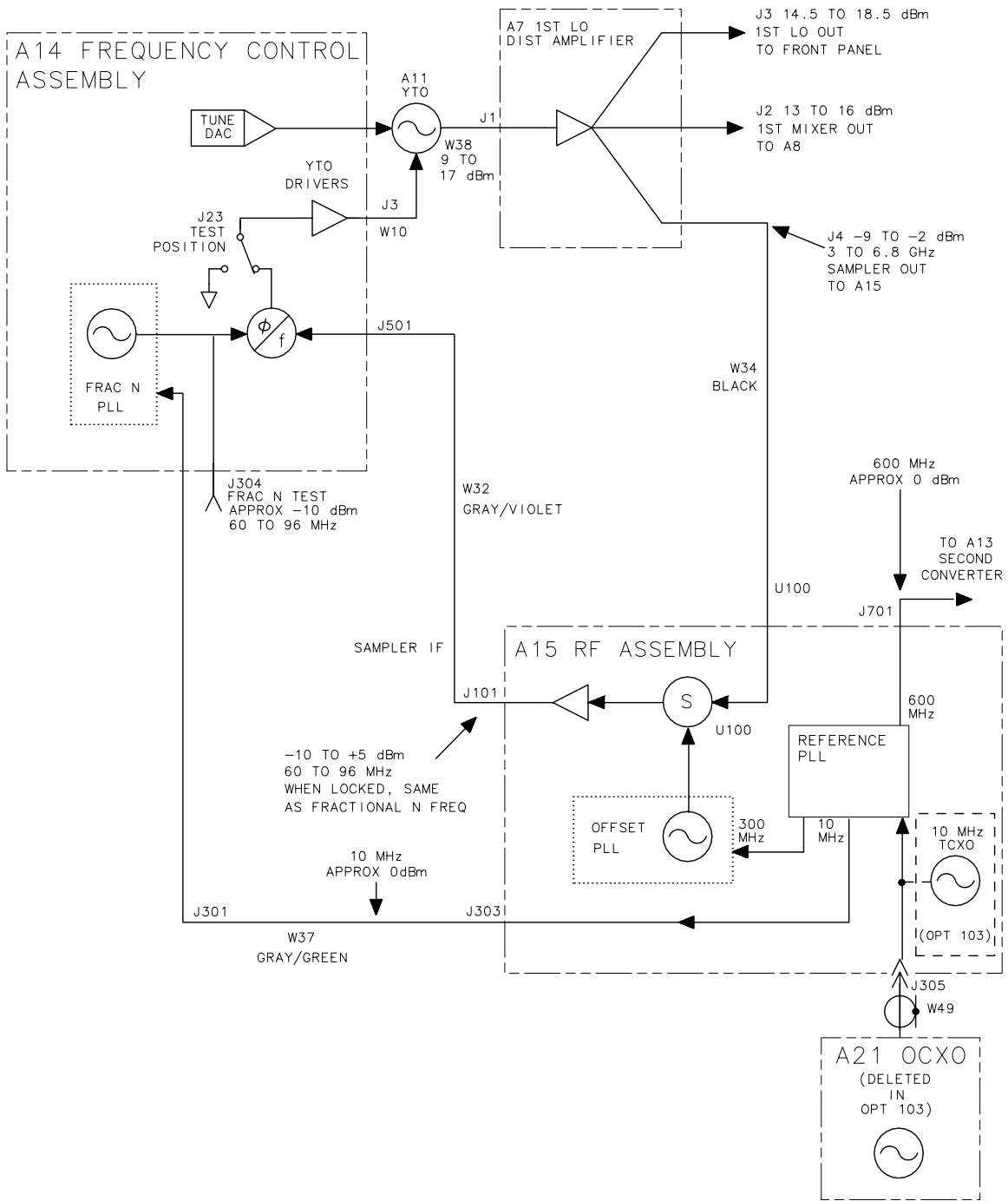

sj160e

Figure 10-12 Simplified A14 Assembly Block Diagram

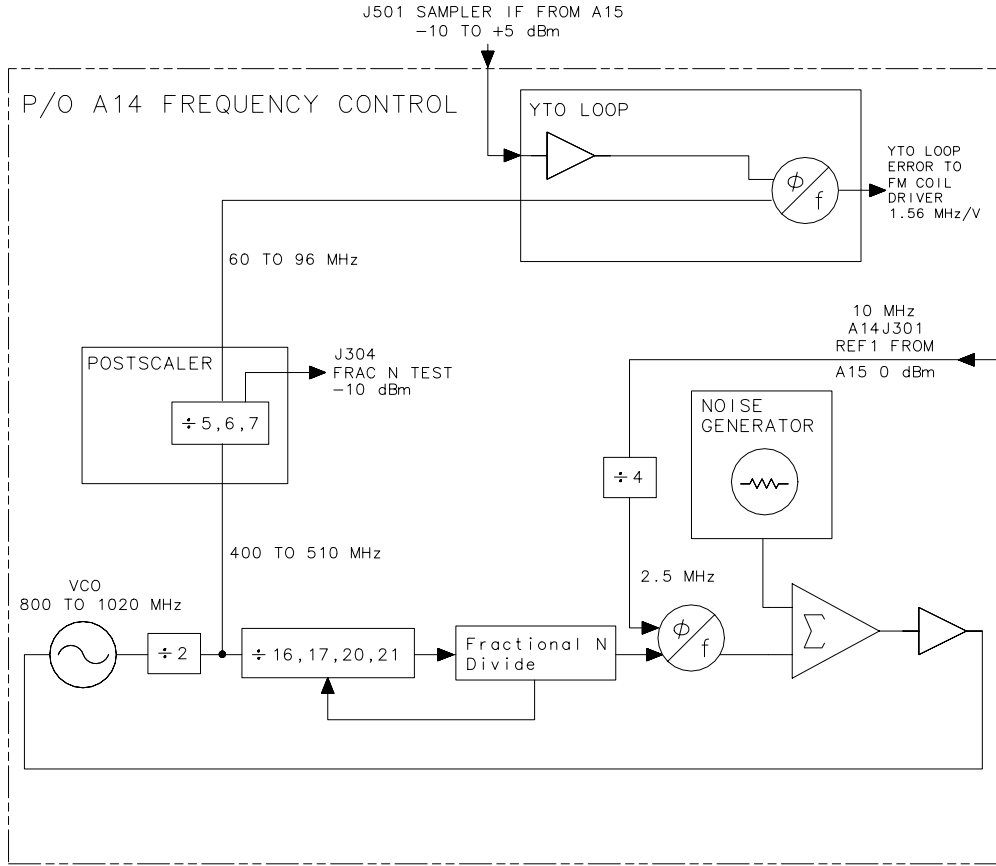

s j146e

Figure 10-13 Simplified A15 Assembly Block Diagram (100 MHz PLL)

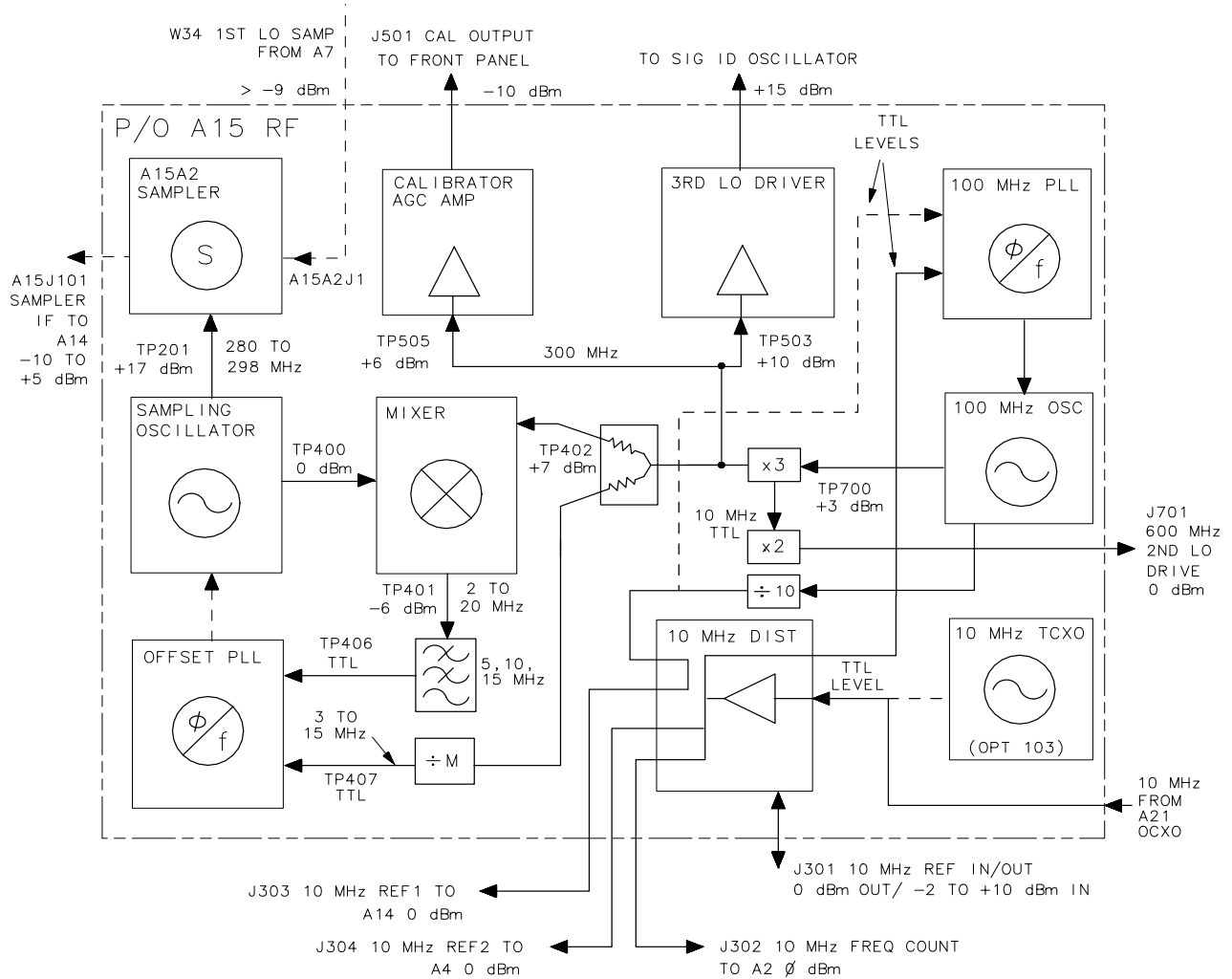

sj161e

Figure 10-13a Simplified A15 Assembly Block Diagram (600 MHz PLL)

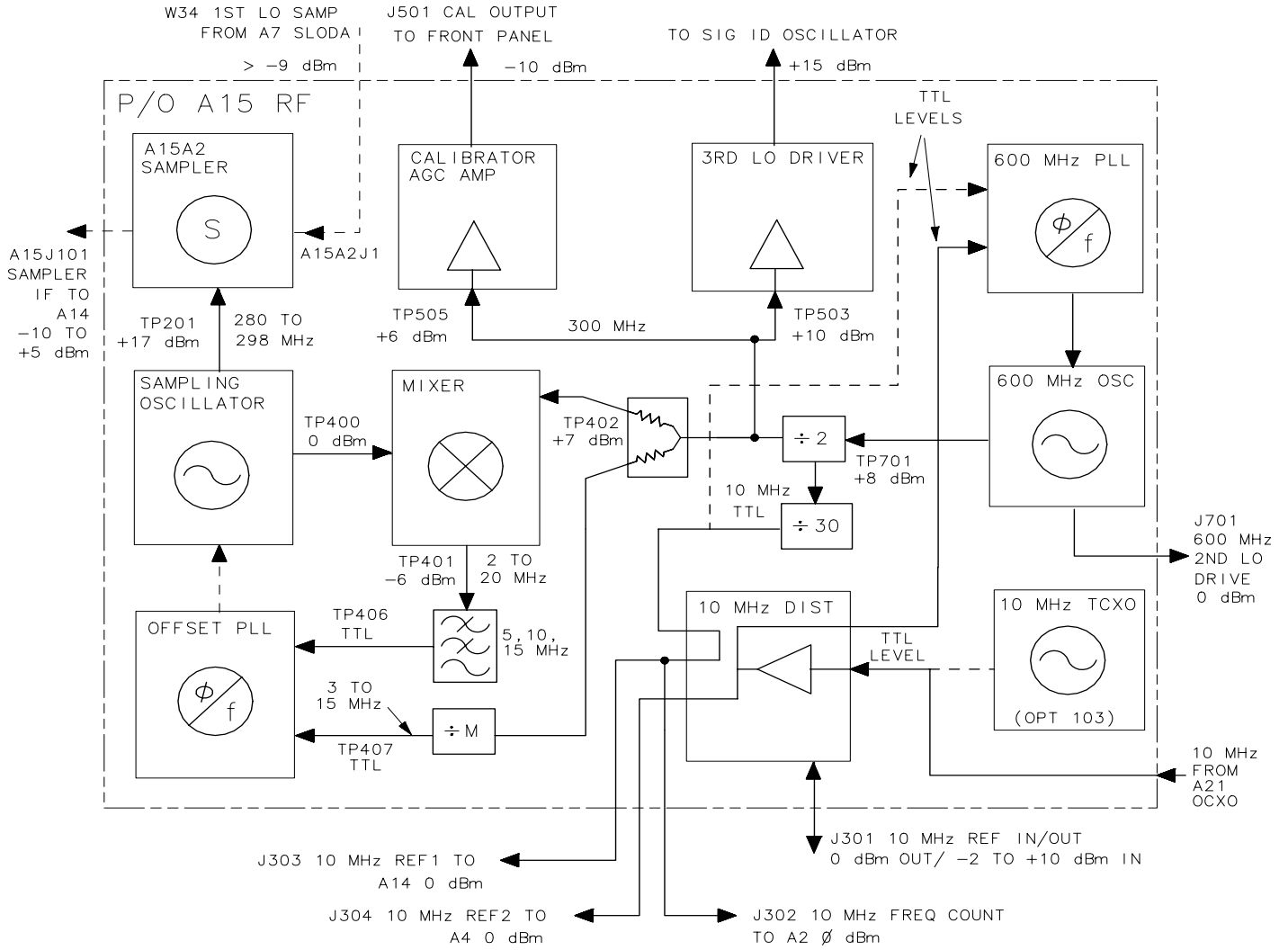

sp134e

A21 OCXO

The spectrum analyzer uses an oven-controlled crystal oscillator (OCXO). It is deleted in Option 103 and replaced by a temperature-compensated crystal oscillator (TCXO), located on the A15 RF assembly. Connectors J305 and J306 on the A15 RF assembly are located where the TCXO would be installed in an Option 103. The oven in the OCXO is powered only when the spectrum analyzer is powered on; there is no standby mode of operation. The OCXO oscillator operates only when the internal frequency reference is selected. Control line HEXT (High = EXTERNAL frequency reference) is inverted by A15U303B to generate LEXT. (Refer to the A15 RF assembly schematic diagram, block M, sheet 2 of 4.) LEXT is sent to the OCXO via A15J306 pin 4. When LEXT is low, the oscillator in the OCXO will be turned off.

Replacement OCXOs are factory adjusted after a complete warmup and after the specified aging rate has been achieved. Thus, readjustment should typically not be necessary after OCXO replacement, and is generally not recommended.

If adjustment is necessary, the spectrum analyzer must be on continuously for a minimum of 24 hours immediately prior to oscillator adjustment to allow both the temperature and frequency of the oscillator to stabilize. Failure to allow sufficient stabilization time could result in oscillator misadjustment.

Check operation of the A21 OCXO as follows:

1. Disconnect W49 (Coax 82) from A15J305. Connect the output of W49 to the input of another spectrum analyzer.
2. Check that the fundamental frequency is 10 MHz and that the power level is 0 dBm \pm 3 dB. Also check that the harmonics are at least -25 dBc. Excessive harmonics can generate spurious responses on the fractional N oscillator on the A14 frequency control assembly.
3. If the OCXO has no output, check A15J306 pin 1 for +15 Vdc. Check A15J306 pin 4 for a TTL-high level.
4. If A15J306 pin 4 is at a TTL-low level, press **AUX CTRL** and **REAR PANEL**. Press **10 MHz EXT INT** until INT is underlined. A15J306 pin 4 should read a TTL-high level. Press **10 MHz EXT INT** until EXT is underlined. A15J306 pin 4 should read a TTL-low level.

Figure 10-14 **Frequency Control Block Diagram**

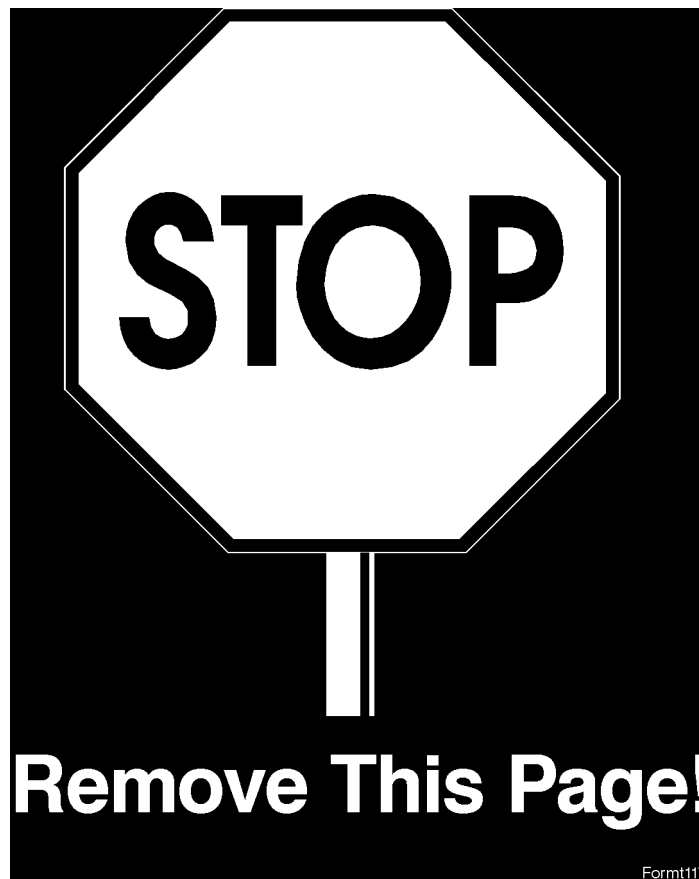

Replace with sj19c

Figure 10-15 RF Block Diagram (for A15 08563-60054, 08563-60055, or 08563-60056)



Replace with sj110c

Figure 10-16 RF Block Diagram (for A15 <08563-60054, 08563-60055, or 08563-60056)

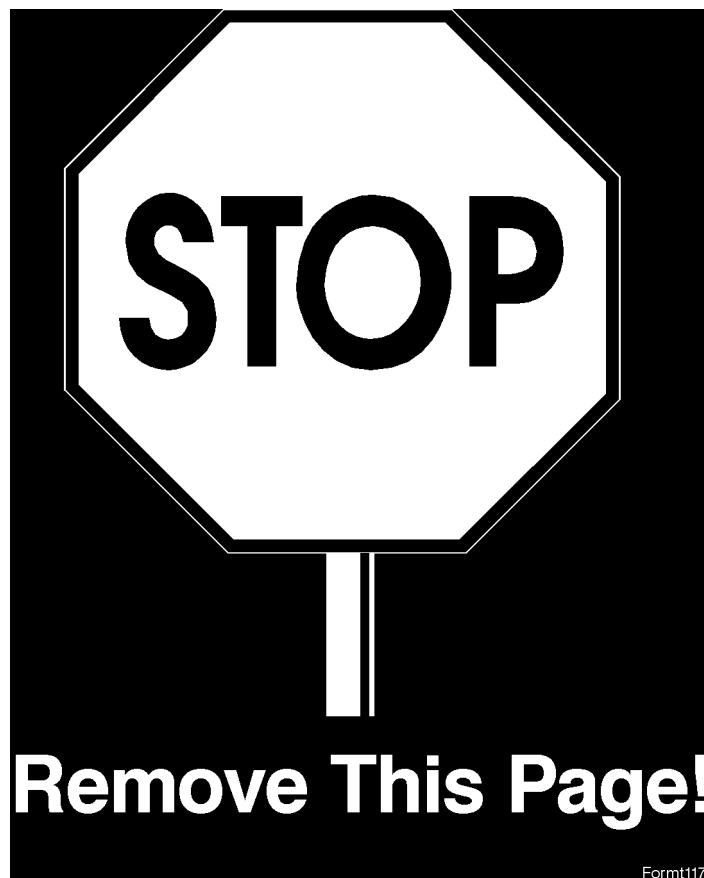

Replace with sj141c

11 **RF Section**

Introduction

The RF section converts the input signal to a 10.7 MHz IF (Intermediate Frequency). See [Figure 11-5 on page 615](#) for a detailed block diagram.

NOTE The block diagrams for the A14 and A15 assemblies are located in Chapter 10, "Synthesizer Section."

| | |
|--|----------|
| Troubleshooting Using the TAM..... | page 584 |
| Low Band Problems (30 Hz to 2.9 GHz) | page 587 |
| Low Band Problems | page 588 |
| A7 LODA (LO Distribution Amplifier)..... | page 589 |
| A8 Low Band Mixer | page 591 |
| A9 Input Attenuator | page 592 |
| A13 Second Converter..... | page 594 |
| A14 Frequency Control Assembly | page 596 |
| A7 LODA Drive | page 596 |
| A15 RF Assembly | page 598 |
| Confirming a Faulty Third Converter..... | page 598 |
| Confirming a Third Converter Output..... | page 598 |
| Third Converter..... | page 599 |
| Flatness Compensation Control | page 600 |
| Control Latches | page 601 |
| SIG ID Oscillator (Option 008)..... | page 602 |
| 10 MHz Reference | page 603 |
| A10 Tracking Generator (Option 002) | page 607 |
| Block Diagram Description..... | page 607 |
| Output Goes Unleveled (ERR 900 or ERR 901) | page 608 |
| Excessive Residual FM | page 610 |
| Flatness Out-of-Tolerance | page 610 |
| Vernier Accuracy Out-of-Tolerance | page 611 |
| Harmonic/Spurious Outputs Too High | page 612 |
| Power Sweep Not Functioning Properly | page 613 |
| No Power Output..... | page 613 |

CAUTION All of the RF assemblies are extremely sensitive to Electrostatic Discharge (ESD). For further information regarding electrostatic cautions, refer to "Electrostatic Discharge" in Chapter 1.

CAUTION

Use of an active probe, such as an HP 85024A, with another spectrum analyzer is recommended for troubleshooting the RF circuitry. If an HP 1120A Active Probe is being used with a spectrum analyzer, such as the HP 8566A/B or the HP 8562A/B, having dc coupled inputs, either set the active probe for an ac coupled output or use a dc blocking capacitor (HP 11240B) between the active probe and the spectrum analyzer input. Failure to do this can result in damage to the spectrum analyzer or to the probe.

Troubleshooting Using the TAM

When using Automatic Fault Isolation, the TAM indicates suspected circuits that need to be manually checked. Use [Table 11-1 on page 584](#) to locate the manual procedure.

[Table 11-2 on page 585](#) lists assembly test connectors associated with each Manual Probe Troubleshooting test. [Figure 11-1 on page 584](#) illustrates the location of A15 test connectors.

Figure 11-1 A14 and A15 Test Connectors

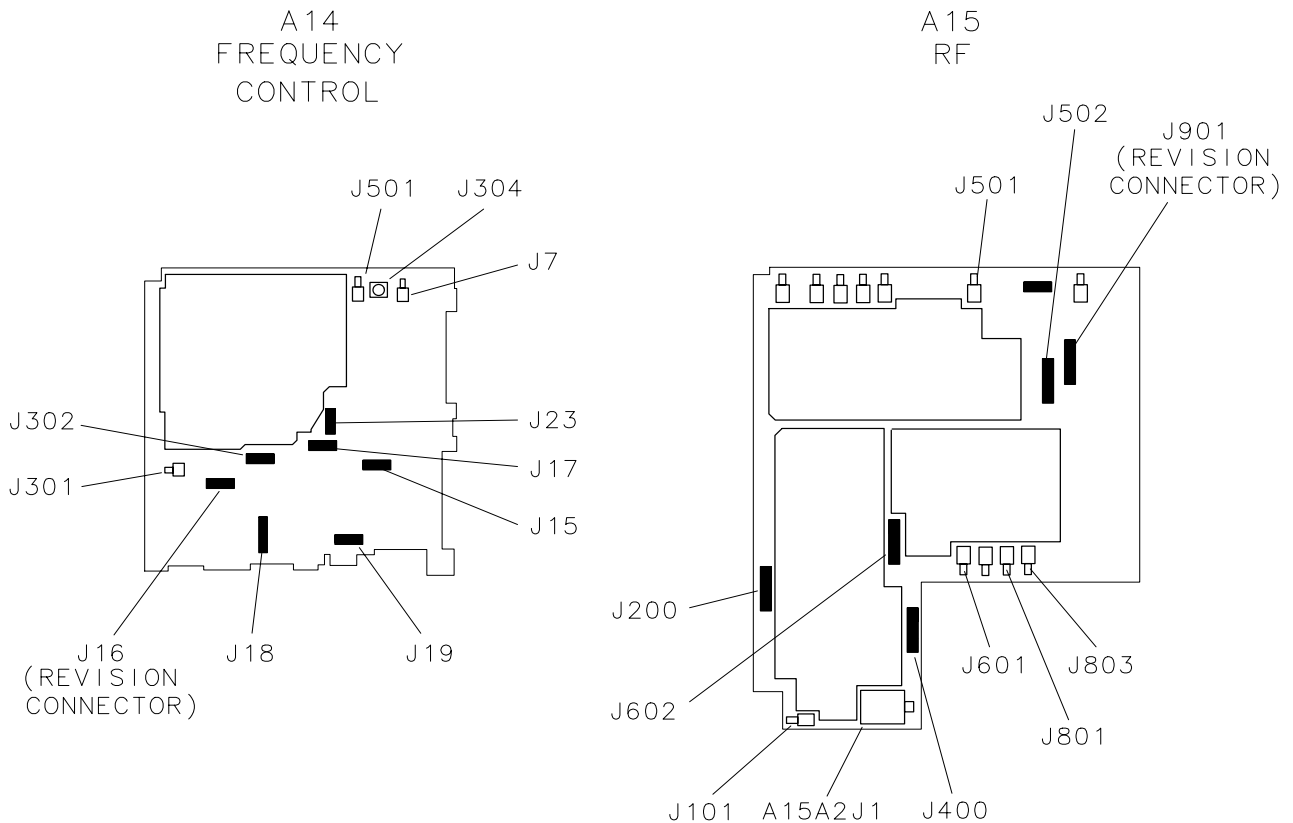

sp128e

Table 11-1 Automatic Fault Isolation References

| Suspected Circuit Indicated by Automatic Fault Isolation | Manual Procedure to Perform |
|--|--|
| Check 2nd IF Amplifier | Third Converter |
| Check 2nd IF Distribution | Third Converter |
| Check 10.7 MHz IF Out of Double Balanced Mixer | Third Converter |
| Check 300 MHz CAL OUTPUT | Calibrator Amplitude Adjustment in Chapter 2 |

Table 11-1 Automatic Fault Isolation References

| Suspected Circuit Indicated by Automatic Fault Isolation | Manual Procedure to Perform |
|---|--|
| Check A7 1st LO Distribution Amplifier | A7 LODA (LO Distribution Amplifier) |
| Check A8 Low Band Mixer | A8 Low Band Mixer |
| Check A9 Input Attenuator | A9 Input Attenuator |
| Check A13 Second Converter | A13 Second Converter |
| Check A13J2 INT 2nd IF | A13 Second Converter (<i>steps 1 to 6</i>) |
| Check A15 Control Latches | Control Latches |
| Check A15J601 10.7 MHz | Third Converter Output |
| Check External 10 MHz Reference Operation | 10 MHz Reference (<i>steps 5 to 11</i>) |
| Check Gain of Flatness Compensation Amplifier | Third Converter |
| Check INT 10 MHz Reference Operation | 10 MHz Reference (<i>steps 1 to 4</i>) |
| Check LO Feedthrough | Low Band Problems (1 kHz to 2.9 GHz) (<i>steps 1 to 3</i>) |
| Check LO Power | Low Band Problems (<i>steps 4 to 9</i>) |
| Check PIN Switch | PIN Switch |
| Check PIN Switches in SIG ID Oscillator | SIG ID Oscillator |
| Check Second Converter Control | A13 Second Converter |
| Check SIG ID Oscillator | Signal ID Oscillator Adjustment in Chapter 2 |
| Check SIG ID Oscillator Operation | SIG ID Oscillator |
| Check Third Converter | Low Band Problems (<i>step 10</i>) |

Table 11-2 TAM Tests versus Test Connectors

| Connector | Manual Probe Troubleshooting Test | Measured Signal Lines |
|------------------|--|------------------------------|
| A14J17 | Main Coil Course DAC | MS3 |
| A14J18 | LODA Drive | MS5, MS6, MS7, MS8 |
| A14J19 | Second Conv PIN Switch Second Conv Mixer Bias | MS8 MS1 |

Table 11-2 TAM Tests versus Test Connectors

| | | |
|---------|--|---|
| A14J19 | Second Conv Drain Bias Second Conv Doubler Bias Second Conv Driver Bias First Mixer Drive Switch First Mixer Drive DAC | MS3 MS4 MS5 MS7 MS6 |
| A14J302 | Revision | MS7 |
| A15J400 | IF AMP/Limiter Bias | MS6 |
| A15J502 | Third LO Tune Voltage 3rd LO Driver Amp | MS3 MS1, MS8 |
| A15J602 | SIG ID Collector Bias RF Gain Control Test | MS7 MS1, MS3 |
| A15J901 | Revision External Mixer Switch Signal ID Switch External Mixer Bias RF Gain Test | MS3 MS1, MS8 MS5, MS6 MS7 MS2 |

Low Band Problems (30 Hz to 2.9 GHz)

1. Disconnect all inputs from the front panel INPUT 50 Ω connector.
2. Set the HP 8560E/EC to the following settings:
Center frequency0 Hz
Span 1 MHz
Input attenuation0 dB
3. The LO feedthrough amplitude observed on the display should be between -6 and -30 dBm.

NOTE

The marker will not peak search on the LO feedthrough when in a non-zero span. To measure the LO feedthrough amplitude with the markers, set the span to 0 Hz and center frequency to 0 Hz. Press **MKR ON**.

4. If the LO feedthrough amplitude is within limits, but signals are low, the RF path following the A8 Low Band Mixer is operating properly.
5. If the LO feedthrough amplitude is higher than -5 dBm (signal will be "clipped" at top of screen) and signals are low in amplitude, suspect a defective A8 Low Band Mixer.
6. Check A13 Second Converter mixer diode bias at A14J19 pin 1. The bias voltage should be between -150 and -900 mV.
7. Troubleshoot the signal path. Refer to the power levels listed on [Figure 11-3 on page 604](#), RF Section Troubleshooting Block Diagram.

Low Band Problems

1. On the HP 8560E/EC, press **PRESET** and **REALIGN LO &IF**. If any error messages are displayed, refer to "Error Messages" in Chapter 6.
2. Perform "External Mixer Amplitude Adjustment" in Chapter 2. If this adjustment cannot be completed, perform the steps located in "Third Converter" in this chapter.
3. Perform the "First LO Output Amplitude" performance test. (Refer to the *HP 8560 E-Series Spectrum Analyzer Calibration Guide* or use the TAM functional test.)
4. If the performance test fails, perform the "First LO Distribution Amplifier Adjustment" in Chapter 2. If the adjustment fails, set the HP 8560E/EC to the following settings:
5. Place the jumper on A14J23 in the TEST position. Remove W38 from the input of the A7 LODA.
6. Use a power meter or another spectrum analyzer to measure the output of A11 YTO. The power should be between +2 dBm and +13 dBm.
7. Reconnect W38 to the LODA. Place the jumper on A14J23 in the NORM position.
8. If ERR 334 (unleveled output) is present and the A11 YTO power output is correct, the A7 LODA drive circuit may be defective. Refer to "A7 LODA (LO Distribution Amplifier)" in this chapter.
9. Troubleshoot the signal path. Refer to the power levels listed on [Figure 11-5 on page 615](#), RF Section Troubleshooting Block Diagram.
10. Check Third Converter as follows:
 - a. On the HP 8560E/EC, press **PRESET** and set the controls as follows:

| | |
|------------------------|---------|
| Center frequency | 300 MHz |
| Span | 0 Hz |
 - b. Inject a -28 dBm, 310.7 MHz signal into A15J801.
 - c. If a flat line is displayed within 2 dB of the reference level, but the "External Mixer Amplitude Adjustment" fails, troubleshoot the A15 RF assembly.

A7 LODA (LO Distribution Amplifier)

NOTE YTO unlock errors may occur if the power delivered to the A15A2 Sampler is less than -9.5 dBm. Frequency response will be degraded in both internal and external mixing modes if the output power is low or unlevelled.

ERROR 334 may be displayed if the LO OUTPUT connector on the front panel is not properly terminated into a 50Ω termination.

CAUTION Connecting or disconnecting the A7 LODA bias with the **LINE** switch on will destroy the A7 LODA. Always press **LINE** to turn spectrum analyzer off before removing or reinstalling W12 to either the A7 LODA or A14J10.

1. Press **LINE** to turn spectrum analyzer off. Disconnect W12 from A14J10.
2. Connect a jumper between A14J10 pin 5 and A14J19 pin 6. Connect a jumper between A14J18 pin 13 and A14J18 pin 1.
3. Connect the positive lead of a DVM to A14J18 pin 14, and the negative lead to A14J18 pin 6.
4. Press **LINE** to turn spectrum analyzer on.
5. The voltage measured on the DVM should be more negative than -9.4 Vdc.
6. Move the jumper from A14J18 pin 1 to A14J18 pin 2. The voltage measured on the DVM should be more positive than $+12.3$ Vdc.
7. If the voltages do not meet the limits listed in steps 5 and 6, troubleshoot the A14 frequency control assembly.
8. Connect the positive DVM lead to A14J10 pin 1.
9. The measured voltage should be approximately $+5$ Vdc. If the voltage is not $+5$ Vdc, troubleshoot the A14 frequency control assembly.
10. Connect the positive lead of a DVM to A14J18 pin 15. The voltage should measure within ± 10 mV of the GATE BIAS voltage listed on A7 LODA label.
11. If this voltage is not within the correct range, refer to "LO Distribution Amplifier Adjustment" in Chapter 2, "Adjustment Procedures."

12. If the voltage varies between 0 Vdc and -2 Vdc, adjust the GATE BIAS for a DVM reading within ± 10 mV of the GATE BIAS voltage listed on A7 LODA label. If the voltage does not vary between 0 Vdc and -2 Vdc, troubleshoot the A14 frequency control assembly.
13. Disconnect the jumper from A14J19 to A14J10. Press **LINE** to turn spectrum analyzer off. Reconnect W12 to A14J10. Press **LINE** to turn spectrum analyzer on.
14. If the DVM reading changes significantly, the A7 LODA is probably defective.

A8 Low Band Mixer

1. Connect the HP 8560E/EC CAL OUTPUT to INPUT 50 Ω
2. Set the HP 8560E/EC as follows:
Center frequency 300 MHz
Span 0 Hz
Input attenuation 10 dB
3. If the spectrum analyzer serial number prefix is 3632A or greater, make sure A8 is receiving the $-5V$ and $-4V$ supply voltages from frequency control board assembly A14 via cable assembly W12.
4. Using another spectrum analyzer, check for approximately -21 dBm (300 MHz) at the input of A8. (This level can easily be measured at the output of FL1 by disconnecting W45 from FL1.)
5. If the level at the input of A8 is less than -25 dBm, suspect FL1 low-pass filter, or A9 input attenuator. Refer to power levels shown on Figure 11-5, RF Section Troubleshooting Block Diagram.
6. Check for approximately -30 dBm (3.9107 GHz) at the output of A8. (This level can easily be measured at the output of FL2 by disconnecting W57 from FL2.)
7. If the level at the output of A8 is less than -35 dBm, suspect A8 low band mixer or FL2 low-pass filter.

A9 Input Attenuator

1. Perform the "Input Attenuator Accuracy" test in the *HP 8560 E-Series Spectrum Analyzer Calibration Guide*.
2. If there is a step-to-step error of approximately 10 dB or more, continue with step 3.
3. On the HP 8560E/EC, press **AMPLITUDE**, and **ATTEN AUTO MAN** until **MAN** is underlined.
4. Step the input attenuator from 0 dB to 70 dB. A "click" should be heard at each step. The absence of a click indicates faulty attenuator drive circuitry.
5. Monitor the pins of A14U420 with a logic probe or DVM while setting the input attenuator to the values listed in [Table 11-3 on page 593](#).

NOTE

The logic levels listed in [Table 11-3 on page 593](#) show the default AC usage (Pin 5 low, Pin 6 high). DC usage (Pin 5 high, Pin 6 low) is not shown.

6. If one or more logic levels listed in [Table 11-3 on page 593](#) is incorrect, disconnect W11 from A14J6 and repeat step 4 checking only pins 3, 5, 11, and 13 of A14U420. Pins 4, 6, 10, and 12 should all read low TTL levels.
7. If one or more logic levels listed in [Table 11-3 on page 593](#) is incorrect with W11 disconnected, troubleshoot the A14 frequency control assembly.
8. If all logic levels are correct, the A9 input attenuator is probably defective.

Table 11-3 Attenuator Pin Values

| | A14U420 Pin Number | | | | | | | |
|----------------------|---------------------------|--------------|-----------|-----------|-------------|-------------|--------------|--------------|
| ATTEN Setting | 3 | 4 | 5 | 6 | 10 | 11 | 12 | 13 |
| (dB) | 20 dB | 20 dB | DC | AC | 40dB | 40dB | 10 dB | 10 dB |
| 0 | high | low | low | high | low | high | low | high |
| 10 | high | low | low | high | low | high | high | low |
| 20 | low | high | low | high | low | high | low | high |
| 30 | low | high | low | high | low | high | high | low |
| 40 | high | low | low | high | high | low | low | high |
| 50 | high | low | low | high | high | low | high | low |
| 60 | low | high | low | high | high | low | low | high |
| 70 | low | high | low | high | high | low | high | low |

A13 Second Converter

CAUTION

The A13 assembly is extremely sensitive to Electrostatic Discharge (ESD). For further information regarding electrostatic cautions, refer to "Electrostatic Discharge Information" in Chapter 1.

1. Connect the HP 8560E/EC CAL OUTPUT to the INPUT 50 Ω connector.
2. Set the HP 8560E/EC to the following settings:
 - Center frequency 300 MHz
 - Span 0 Hz
 - Input attenuation 10 dB
3. Disconnect W35 (coax 92) from A13J2.
4. Connect a test cable from A13J2 to the input of another spectrum analyzer.
5. Tune the other spectrum analyzer to 310.7 MHz. The signal displayed on the other spectrum analyzer should be approximately -38 dBm.
6. Remove the test cable from A13J2 and reconnect W35 to A13J2.
7. Disconnect W33 (coax81) from A13J4 and connect W33 through a test cable to the input of another spectrum analyzer.
8. Tune the other spectrum analyzer to a center frequency of 600 MHz.
9. If a 600 MHz signal is not present, or its amplitude is less than -5 dBm, the fault is probably on the A15 RF assembly.
10. Reconnect W33 to A13J4.
11. Connect the positive lead of a DVM to A14J19 pin 15, and the negative lead to A14J19 pin 6.
12. If the DVM does not measure between +14.0 Vdc and +15.0 Vdc, perform the following:
 - a. Press **LINE** to turn spectrum analyzer off and disconnect W13 from A14J12.
 - b. Press **LINE** to turn spectrum analyzer on and set the spectrum analyzer to the following settings:
 - Center frequency 300 MHz
 - Span 10 MHz

- c. The voltage should measure +15 Vdc \pm 0.2 V. If the voltage measures outside this limit, the A14 frequency control assembly is probably defective.
- d. Press **LINE** to turn spectrum analyzer off, reconnect W13 to A14J12, and press **LINE** to turn spectrum analyzer on. Set the HP 8560E/EC to the following settings:

Center frequency 300 MHz
Span0 Hz

13. Move the positive lead of the DVM to A14J19 pin 1. The voltage should measure between -150 m Vdc and -800 mVdc. If the voltage measures outside this limit, the A13 Second Converter is probably defective.

A14 Frequency Control Assembly

NOTE The block diagrams for the A14 and A15 assemblies are located in Chapter 10, "Synthesizer Section."

A7 LODA Drive

Refer to function block Z on the A14 Frequency Control schematic in the *HP 8560 E-Series Spectrum Analyzer Component Level Information*.

1. Set the HP 8560E/EC to the following settings:

Center frequency 300 MHz
Span 2 MHz

2. On the HP 8560E/EC, press **SGL SWP** and measure the signal power at the output of A7 (see item **(1)** of [Figure 11-2 on page 597](#)).
3. If the output power is low, the A14U429B output voltage at A14J18 pin 14 (item **(2)** of [Figure 11-2 on page 597](#)) should be greater than 0 V. If the output power is high, the voltage should be more negative than -10 V. If the voltages do not measure as indicated, check that the voltages at A14J18 pins 5 and 13, item **(4)**, are consistent with the output of the operational amplifier.

NOTE If a TAM is available, use Manual Probe Troubleshooting to make measurements on A14J18 pins 5, 13, and 14. These voltages are referred to as AMP CNTL, LO SENSE, and PIN ATTEN respectively.

4. If the voltages measure as indicated in step 3, measure the A11 YTO output. (See item **(3)** of [Figure 11-2 on page 597](#).)
5. If all measurements are within limits, refer to "A7 LODA (LO Distribution Amplifier)" in this chapter.

Figure 11-2 A7 LODA Drive

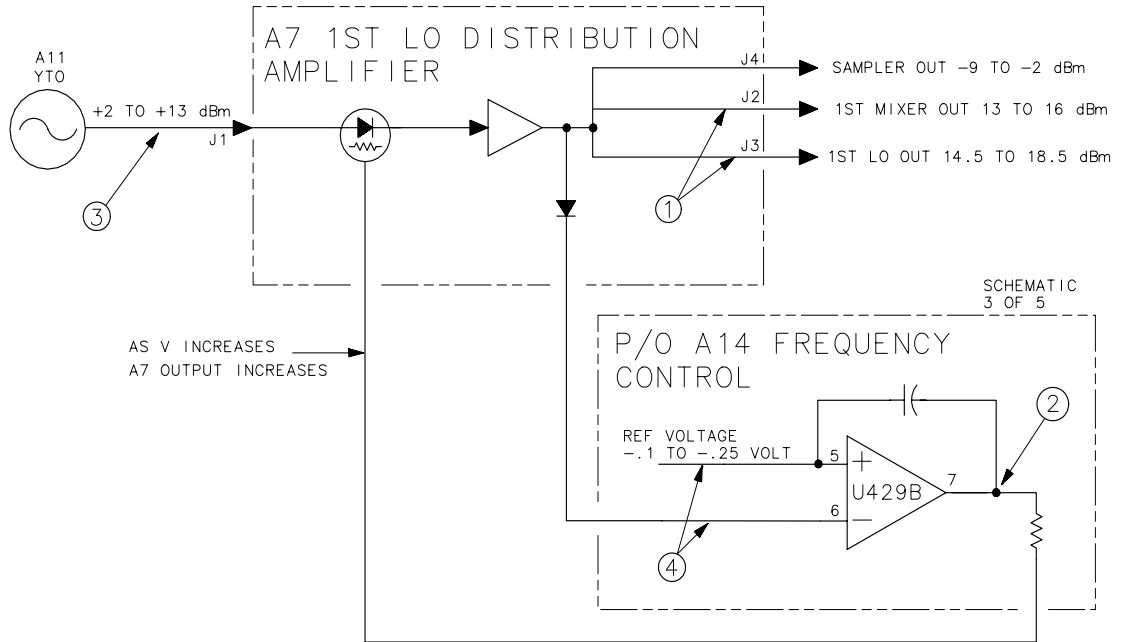

s j 129e

A15 RF Assembly

NOTE The block diagrams for the A14 and A15 assemblies are located in Chapter 10, "Synthesizer Section."

Confirming a Faulty Third Converter

1. Perform the "IF Input Amplitude Accuracy" performance test in the *HP 8560 E-Series Spectrum Analyzer Calibration Guide* if Option 002 is not present. This exercises most of the third converter.
2. If the performance test fails or Option 002 is present, perform the "External Mixer Amplitude Adjustment" in Chapter 2.
3. If adjustment cannot be made, disconnect W35 (coax 92) from A15J801.
4. On the HP 8560E/EC, press **PRESET** and set the controls to the following settings:

Center frequency 300 MHz
Span 0 Hz

5. Connect a signal generator to A15J801.
6. Set the signal generator to the following settings:
Frequency 310.7 MHz CW
Power -28 dBm
7. If a flat line is displayed within 2 dB of the reference level and the performance test passed, troubleshoot microcircuits A7, A8, A9, and A13.
8. If a flat line is displayed within 2 dB of the reference level and the performance test failed, troubleshoot the A15 RF Assembly.
9. Disconnect the signal generator and reconnect W35 (coax 92) to A15J801.

Confirming a Third Converter Output

1. Connect the HP 8560E/EC CAL OUTPUT to the INPUT 50 Ω connector.
2. Set the HP 8560E/EC to the following settings:
Center frequency 300 MHz
Span 0 Hz
Input attenuation 10 dB
3. Press **SGL SWP, CAL, IF ADJ OFF**.

4. Disconnect W29 (coax 7) from A15J601.
5. Connect a test cable from A15J601 to the input of another spectrum analyzer.
6. Tune the other spectrum analyzer to 10.7 MHz. The signal displayed on the other spectrum analyzer should be approximately -15 dBm.
7. Remove the test cable from A15J601 and reconnect W29 to A15J601.

Third Converter

Refer to function blocks A, B, C, D, and E on A15 RF Section schematic in the *HP 8560 E-Series Spectrum Analyzer Component Level Information*.

The 3rd converter consists of the 2nd IF distribution, 2nd IF amplifier, double balanced mixer, 10.7 MHz bandpass filter, and flatness compensation amplifier. The 2nd IF distribution switches between two possible 2nd IF inputs: the internally generated 2nd IF, or the external mixing IF INPUT (non-Option 002 spectrum analyzers only). A variable dc bias can be applied to the IF INPUT for external mixers which require such bias. The selected input is fed to the 2nd IF Amplifier. This amplifier consists of four stages of gain and two stages of SAW filters for image frequency rejection.

The flatness compensation amplifier consists of two fixed-gain stages and two stages of variable gain. This provides an overall adjustable gain of 4 dB to 30 dB. This gain is adjusted during a spectrum analyzer sweep to compensate for front-end conversion loss versus frequency. Perform the following steps to test the amplifier gain:

The 10.7 MHz bandpass filter provides a broadband termination to the mixer while filtering out unwanted mixer products.

1. On the HP 8560E/EC, press **AUX CTRL**, then **INTERNAL MIXER**.
2. In the 2nd IF distribution (function block A), diode CR802 should be forward biased and diode CR801 should be reverse biased.
3. Disconnect W35 (coax 92) and connect a signal source to A15J801. Set the source to the following settings:

Frequency 310.7 MHz
Amplitude -30 dBm

4. Use an active probe with another spectrum analyzer to measure the signal at A15TP601 (function block C). The signal should measure -17 dBm ± 4 dB confirming the operation of the 2nd IF Amplifier.
5. Use an active probe with another spectrum analyzer to measure the 300 MHz into the LO port of the third mixer. The signal should measure at least $+20$ dBm.
6. Measure the power of the mixer 10.7 MHz IF output. The signal

level should be approximately -22 dBm.

7. Move the A2 controller assembly WR PROT/WR ENA jumper to the WR ENA position.
8. While measuring the signal at the mixer 10.7 MHz IF output, adjust the signal source until the level of the 10.7 MHz IF is -40 dBm.
9. On the HP 8560E/EC, press **SGL SWP**, **CAL**, **IF ADJ OFF**, **MORE 1 OF 2**, and **FLATNESS**. Increase the gain of the flatness compensation amplifiers to maximum by entering 0 using the data keys. This sets the gains in the flatness compensation amplifiers to their maximum values.
10. Connect the other spectrum analyzer to A15J601 and measure the 10.7 MHz IF signal level. The signal should measure greater than -10 dBm. If the signal level is incorrect, continue with step 13.
11. Enter 4095 into the HP 8560E/EC Flatness Data. The signal level at A15J601 should measure less than -36 dBm. This sets the gain of flatness compensation amplifiers to a minimum. If the signal level is incorrect, continue with step 13.
12. Check that the gain stages are properly biased and functioning.
13. Check the attenuator stages and flatness compensation control circuitry.
 - a. For minimum gain (flatness data equals 4095), RF GAIN (A15U909 pin 10) should be at -1.6 Vdc and the current through each section as measured across R667 or R668 should be about 7 mA.
 - b. For maximum gain (flatness data equals 0), RF GAIN (A15U909 pin 10) should be at approximately 0 Vdc and the current through each attenuator section should be close to 0 mA.

CAUTION

As long as the flatness data just entered is not stored, the previously-stored flatness data will be present after the power is cycled.

14. Move the WR PROT/WR ENA jumper on the A2 controller assembly to the WR PROT position.
15. Reconnect the cable to A15J801.

Flatness Compensation Control

Refer to function block G on A15 RF Section schematic in the *HP 8560 E-Series Spectrum Analyzer Component Level Information*.

The flatness compensation control consists of a buffer amp (U909C) and two identical voltage-to-current converters (U909B and U909D). The thermistor RT901 in the buffer amp provides temperature compensation for the PIN diodes in the gain stages and the SAW filters.

The gain of the Flatness compensation amplifiers is driven to a minimum by the REDIR line going low during automatic IF adjustment.

Control Latches

Refer to function block H on A15 RF Section schematic in the *HP 8560 E-Series Spectrum Analyzer Component Level Information*. The control latches control the PIN switch drivers illustrated in Function Block I.

1. Connect positive lead of a DVM to A15J901 pin 15 (HEXTMIX). Connect the negative lead to A15J901 pin 6. The measured signal controls the switching between internal and external IF signals.
2. On the HP 8560E/EC, press **AUX CTRL** and **EXTERNAL MIXER**. The voltage on the DVM should measure approximately +5 Vdc (TTL high).
3. On the HP 8560E/EC, press **AUX CTRL** and **INTERNAL MIXER**. The voltage on the DVM should measure approximately 0 Vdc (TTL low).
4. Connect the positive lead of a DVM to A15J901 pin 13 (LSID). The signal measured turns on the SIG ID oscillator (Option 002 only).
5. *For Option 002 spectrum analyzers:* Press **SIG ID ON**, **SGL SWP**. Subsequent pushes of **SGL SWP** should cause the signal measured on the DVM to toggle between TTL high and low levels.
6. Connect an oscilloscope probe to A15U902 pin 7 (LRDIR) and the probe ground lead to A15J901 pin 6. The signal measured controls the flatness compensation circuit.
7. On the HP 8560E/EC, press **PRESET** and set the **SPAN** to 1 MHz.
8. Set the oscilloscope for the following settings:
Amplitude Scale2 V/div
Sweep Time 20 ms/div
9. The waveform should be at a TTL high during part of the retrace period and a TTL low during the sweep (about 50 ms).

SIG ID Oscillator (Option 008)

See Function Block F of A15 RF schematic in the *HP 8560 E-Series Spectrum Analyzer Component Level Information*.

The SIG ID oscillator provides a shifted third LO (approximately 298 MHz) to distinguish true signals from false signals (such as image or multiple responses). When the HP 8560E/EC is set to **SIG ID ON**, the SIG ID oscillator turns on during alternate sweeps (Option 008 spectrum analyzers only).

1. Set the HP 8560E/EC to the following settings:

Trigger single sweep
SIG ID on

2. Use an active probe with another spectrum analyzer to measure the signal level at A15TP602.
3. On the HP 8560E/EC, press **SGL SWP**. With each press of **SGL SWP**, the spectrum analyzer alternates between the following two states:

State 1:

A15J901 pin 13 (LSID) TTL low
SIG ID oscillator ON
Signal at A15TP602 298 MHz \pm 50 kHz (at least +1 dBm)

State 1:

A15J901 pin 13 (LSID)..... TTL high
SIG ID oscillator OFF
3rd LO driver amplifier Provides LO for double balanced mixer

4. With the SIG ID oscillator on, measure the frequency at A15TP602 with a frequency counter and an active probe. If the frequency is not 298 MHz \pm 50 kHz, refer to the "SIG ID Oscillator Adjustment" procedure in Chapter 2. (There is no adjustment for instruments with A15 RF assembly 08563-60084 or greater.)
5. On the HP 8560E/EC, press **SGL SWP** until A15J901 pin 13 is at TTL low. Diodes CR603 and CR605 should be forward biased and CR604 should be reverse biased (approximately 6 Vdc reverse bias). Diodes CR501 and CR502 should be forward biased, disabling the 3rd LO driver amplifier.

6. The voltage at the R622/R623 node should measure approximately -5 Vdc, biasing Q604 on.
7. If oscillator bias voltages are correct, place a $100\ \Omega$ resistor across SAWR U602 input and output. If the SAWR has failed, this will provide the equivalent loss of a correctly functioning SAWR, and the circuit will begin to oscillate.

10 MHz Reference

The spectrum analyzer 10 MHz reference consists of 10 MHz OCXO (Option 103: TCXO) with associated TTL level generator and distribution circuitry. The OCXO (or TCXO) and TTL level generator are turned off when an external 10 MHz reference is used. Also, with the spectrum analyzer set to EXTERNAL frequency reference, U304A output (low) forces the output of U304D to stay high. This allows U304B to control the outputs of U303B, U304C, and U303D. In INTERNAL frequency reference, U304D controls the outputs of these three NAND gates, and the output of U304B is held high.

Check the 10 MHz reference by performing the following steps:

1. Set the HP 8560E/EC 10 MHz reference to internal by pressing **AUX CTRL**, **REAR PANEL**, and **10 MHz INT**.
2. Use a spectrum analyzer to confirm the presence of a 10 MHz signal at the following test points:

| | |
|---------------|----------------|
| A15J303 | ≥ -10 dBm |
| A15J304 | ≥ -10 dBm |
| A15J301 | ≥ -2 dBm |
3. Check for a 1.3 V p-p waveform at A15J302 using an oscilloscope (see [Figure 11-3 on page 604](#)).
4. Check that the signal at A15J301 is 10 MHz ± 40 Hz (with Option 103 TCXO reference) using a frequency counter. If necessary, perform the appropriate 10 MHz reference adjustment.
5. If there is no problem with INTERNAL 10 MHz reference operation, check EXTERNAL 10 MHz reference operation as follows:
6. Set the HP 8560E/EC 's 10 MHz reference to external by pressing **10 MHz EXT**.
7. Connect a 10 MHz, -2 dBm, signal to the rear panel 10 MHz REF IN/OUT connector.
8. Check the signals at A15J301, A15J302, A15J303, and A15J304 according to the procedure in steps 2 through 4.

9. If the signals are correct in EXTERNAL operation, but not in INTERNAL operation, the problem lies in A21 OCXO (or Option 103 TCXO), its voltage reference, or the TTL level generator. Check these areas as follows:
 - a. On the HP 8560E/EC, press **10 MHz INT**.
 - b. Check U305 pin 3 for approximately +12 Vdc (Option 103 only).
 - c. Check for a 10 MHz sine wave greater than or equal to 1 V p-p at J305 (standard HP 8563E), or at U302 pin 3 with an oscilloscope (Option 103).
10. If the signal at U304 pin 13 is correct (see [Figure 11-4 on page 605](#)), but there is a problem with the signals at A15J301, A15J302, A15J303, or A15J304, suspect U303 or U304 in the 10 MHz distribution circuitry.

Figure 11-3 10 MHz Reference at A15J302

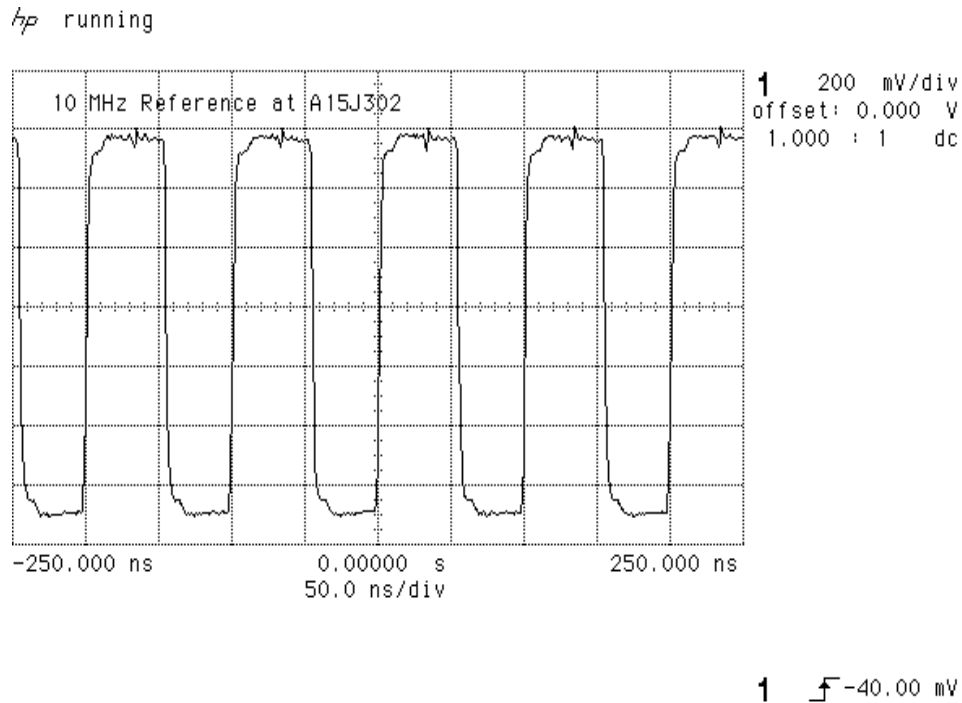

Figure 11-4 10 MHz TTL Reference at U304 Pin 13

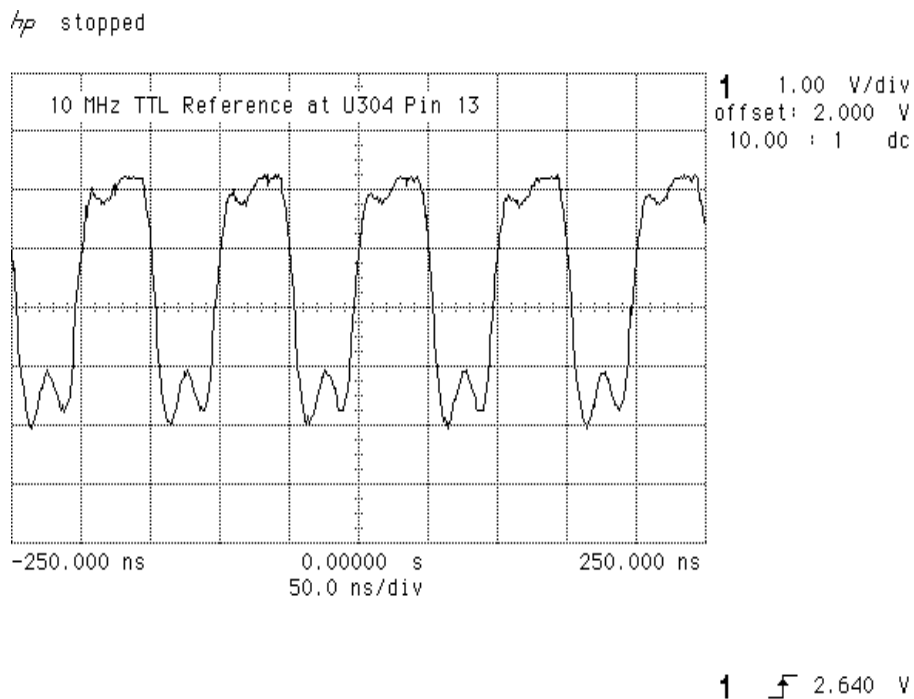

Table 11-4 on page 606 lists the RF Section mnemonics shown in Figure 11-5 on page 615 and provides a brief description of each.

Table 11-4 RF Section Mnemonic Table

| Mnemonic | Description |
|---------------------------|--|
| MAIN COIL+, MAIN COIL- | YTO main coil tune signal |
| FM+, FM- | YTO FM coil tune signal |
| LO SENSE | LO amplitude sense voltage |
| LEVEL ADJUST | LO amplitude adjustment voltage (PIN ATTEN) |
| GATE BIAS | LODA gate bias voltage |
| HEXTMIXB | External Mixer: +12V=EXT MIX |
| | -12V=INT MIX |
| HSIGIDOFFA | SIG ID Oscillator ON: +12V=SIG ID OFF |
| | -8V=SIG ID ON |
| PIN DIODE SWITCH | PIN diode switch control for 2ND conv. IF output |
| MIXER BIAS | Detected voltage on 2ND converter mixer diode |
| RFGAIN | Voltage to control gain of flatness comp. amps. |
| RFGAIN1 and RFGAIN2 | Currents to drive PIN diodes in flatness comp. amps. |
| L10dB A, L20dB B, L40dB C | Control lines to set attenuator sections A, B, and C |
| | to attenuate position (active low) |
| 10dB A, 20dB B, 40dB C | Control lines to set attenuator sections A, B, and C |
| | to attenuate position (active high) |
| LDC D, LAC D | Control lines to toggle DC/AC input |

A10 Tracking Generator (Option 002)

Block Diagram Description

The A10 tracking generator consists of several smaller circuits. The A10 is not component-level repairable; a rebuilt exchange assembly is available.

The block diagram of the tracking generator is unique in that it only recreates one intermediate frequency of the spectrum analyzer. This minimizes isolation problems associated with a built-in tracking generator. Each of the blocks comprising the A10 tracking generator is described below.

Tracking Oscillator

The tracking oscillator enables the fine adjustment of the tracking generator output frequency to compensate for the frequency inaccuracies of the spectrum analyzer 10.7 MHz IF. The tracking oscillator determines the residual FM and frequency drift of the tracking generator. The 182.14 MHz output frequency is obtained by doubling the output of a crystal oscillator operating at 91.07 MHz.

Upconverter

The upconverter mixes the tracking oscillator output with the buffered 600 MHz reference from the A15 RF assembly. The upconverter also contains a filter to pass only the 782.14 MHz upper sideband.

Pentupler

The pentupler multiplies the 782.14 MHz signal by five to generate 3.9107 GHz, the spectrum analyzer 1st IF. A dual cavity bandpass filter centered at 3.9107 GHz eliminates all unwanted multiples of 782.14 MHz.

Modulator

The output of the pentupler is passed through a modulator to adjust the power level into the output mixer. The modulator is controlled by an ALC circuit on the bias board which is fed by a detector in the output amplifier. If the detected output power is too high, the ALC will drive the Modulator to decrease the input level into the output mixer, resulting in a decrease in output power.

Coupler

The 1st LO signal from the A7 LODA is coupled off and buffered to drive the output mixer. The main line of the coupler is fed to the 1ST LO OUTPUT on the front panel. The loss through the coupler main line is less than 2.5 dB.

Output Mixer

The 3.9107 GHz signal from the modulator is fed into the RF port of the output mixer. The LO port of the output mixer is driven by the buffered 1st LO signal from the coupler. The output of the mixer is then amplified.

Output Amplifier

The output amplifier low-pass filters the signal emerging from the output mixer and then amplifies it into a usable range. The amplifier also contains a detector for leveling the output.

Bias Board

The bias board contains the ALC circuitry for the tracking generator and distributes dc power from the A14 frequency control assembly to the rest of the tracking generator. The ALC inputs come from the A14 frequency control assembly (for controlling the power level), the EXT ALC INPUT on the rear panel, and the detector in the output amplifier. The ALC loop drives the modulator.

The following troubleshooting information is aimed at isolating tracking-generator-related faults to either the A10 tracking generator assembly, or one of the other supporting assemblies, such as A14, A15, or A7. The A10 tracking generator is not field-repairable; a rebuilt-exchange assembly is available.

Output Goes Unleveled (ERR 900 or ERR 901)

The ADC on the A3 interface assembly is used to monitor the control line ALC MON (ALC Monitor) from A10. If ALC MON is greater than +1.091 Vdc or less than -0.545 Vdc, ERR 900 TG UNLVL will be displayed, indicating that the output of the tracking generator (or "TG") is unleveled. The TG can typically be set for +2.8 dBm output power and remain leveled. In any case, the output should remain leveled for output power settings of less than the maximum leveled output power. Refer to the specifications chapter in the *HP 8560 E-Series Spectrum Analyzer Calibration Guide* for more information on this specification.

It is normal for the TG to be unleveled at frequencies less than 300 kHz. If the TG output is unleveled and the start frequency of the TG is less than 300 kHz, ERR 901 TGFrqLmt (TG Frequency Limit) and ERR 900 TG UNLVL may be displayed. (Refer to Chapter 6, "General Troubleshooting," for information on checking for multiple error

messages.) If the start frequency is changed to be greater than 300 kHz and the output is still unlevelled, **ERR 900 TG UNLVL** will be displayed (see above).

The ALC MON line is monitored only at the end of a sweep. For this reason, it is possible that the output could be unlevelled during a portion of a sweep, and, if the output returns to a levelled condition by the end of the sweep, **ERR 900 TG UNLVL** will not be displayed.

If **ERR 900 TG UNLVL** is displayed, proceed as follows:

1. Check at which frequencies the output is unlevelled. Set the spectrum analyzer to zero span and step the center frequency in 50 MHz increments. Note at which frequencies the output is unlevelled.
2. Check at which power levels the output is unlevelled. Connect the RF OUT 50 Ω to the INPUT 50 Ω connector. With the spectrum analyzer in zero span, set the center frequency to 300 MHz or one of the frequencies noted in step 1. Press **AUXCTRL, TRACKING GENERATOR, SRC PWR ON, MORE 1 OF 3, TRACKING PEAK**. Wait for the "PEAKING" message to disappear. Step the TRK GEN RF POWER setting in 1 dB increments and note at which power levels the output is unlevelled. It is acceptable for the output to be unlevelled only at power levels greater than the specified maximum levelled output power level.
3. Check maximum power available from the TG. Connect the RF OUT 50 Ω to the INPUT 50 Ω connector. Press **PRESET, AMPLITUDE, 2, 0, + dBm, LOG dB/DIV, 5, dB, AUX CTRL, TRACKING GENERATOR, SRC PWR ON, MORE 1 OF 3, ALC EXT**. No connection should be made to the ALC EXT INPUT connector on the rear panel. The available power should always be greater than +1 dBm. If the output is unlevelled only at specific frequencies, a power hole will usually be visible at those frequencies.
4. Perform the "1ST LO OUTPUT Amplitude" performance test. If the test fails, note the center frequency setting at which the power level was out-of-tolerance. Repeat the test with the power sensor connected to A7J3 (a right-angle SMA adapter will be necessary) and note the center frequency of any out-of-tolerance power levels. The power level should be +16.5 dBm \pm 2 dB.

If the power level is correct at W43 but out-of-tolerance at the 1ST LO OUTPUT (front panel), and the center frequency setting of the out-of-tolerance power levels is close to the frequencies at which the output is unlevelled, suspect either A10 or W46.

If the power level at W43 is also out-of-tolerance, suspect either the A7 LODA or the A11 YTO. Refer to Chapter 10, "Synthesizer Section."

5. If the output is unlevelled only at certain power level settings or certain frequencies, monitor A17J16 pin 1 with a DVM. Connect the

negative DVM lead to A17J16 pin 6. Vary the TRK GEN RF POWER or center frequency settings, as appropriate, and plot the voltage variation versus power level or frequency. A discontinuity in the plot near the frequency or power level at which the output is unlevelled indicates a problem on the A14 frequency control assembly.

Excessive Residual FM

Either the tracking oscillator or the ALC circuitry could be responsible for excessive residual FM. The residual FM should be measured on another spectrum analyzer, such as an HP 8566A/B or HP 8568A/B, using slope detection with the HP 8560E/EC set to zero span.

Proceed as follows to troubleshoot residual FM problems:

1. Perform the "Residual FM" performance test for the spectrum analyzer in the *HP 8560 E-Series Spectrum Analyzer Calibration Guide*. If this test passes, the 1st LO input and 600 MHz drive signals should be correct. If the test fails, troubleshoot the synthesizer section.
2. Monitor A14J17 pin 15 (TUNE +) with an oscilloscope. Connect the oscilloscope probe ground lead to A14J17 pin 6. The voltage at this point should be greater than 500 mV. If the voltage is less than 500 mV, perform the "Tracking Oscillator Range" performance test in the *HP 8560 E-Series Spectrum Analyzer Calibration Guide*. If this test fails, perform the "Tracking Oscillator Range Adjustment". If the noise on this tune line is greater than 10 mV, troubleshoot the BITG drive circuitry on A14.
3. Monitor the output of the tracking generator with another spectrum analyzer. Check for high-amplitude spurious responses from 100 kHz to at least 3 GHz. If the spurious responses are too high in amplitude, the (broadband) ALC detector may cause the ALC loop to oscillate, generating FM sidebands. If any spurious responses are excessively high, refer to "Harmonic/Spurious Outputs Too High" in this chapter.
4. If no spurious responses are present or are sufficiently low enough in amplitude to not cause a problem, suspect the tracking oscillator in A10.

Flatness Out-of-Tolerance

The output level flatness of the tracking generator is specified at a 0 dBm output power setting. In general, most flatness problems will be a result of a failure in the A10 tracking generator microcircuit. However, the POWER LVL signal from the A14 frequency control assembly and the 1ST LO IN signal from the A7 LODA can also contribute to flatness problems.

1. Check the function of the POWER LVL signal from the A14

frequency control assembly. Set the TRK GEN RF POWER to a level at which the flatness is out-of-tolerance. Monitor A17J16 pin 1 with a DVM and step the center frequency in 100 MHz increments from 100 MHz to 2.9 GHz and plot the voltage variation versus frequency. A discontinuity in the plot near the frequency at which the flatness is out-of-tolerance indicates a problem on the A14 frequency control assembly.

2. Check the flatness of the 1ST LO IN signal. Perform the "1ST LO OUTPUT Amplitude" performance test. If the test passes, the fault is most likely in the A10 tracking generator. If the test fails, note the center frequency setting at which the power level was out-of-tolerance and compare against the frequency(ies) at which the flatness was out-of-tolerance. Repeat the test with the power sensor connected to the end of W43 nearest A10, noting the center frequency of any out-of-tolerance power levels. The power level should be $+16.5 \text{ dBm} \pm 2 \text{ dB}$.

If the power level is correct at W43 but out-of-tolerance at the 1ST LO OUTPUT, and the center frequency setting of the out-of-tolerance power levels is close to the frequencies at which the output is unlevelled, suspect A10.

If the power level at W43 is also out-of-tolerance, suspect either the A7 LODA or the A11 YTO. Refer to Chapter 10, "Synthesizer Section."

3. Check all coax cables, especially semi-rigid cables. A fault in one of these cables can cause a very high-Q power hole.

Vernier Accuracy Out-of-Tolerance

Vernier accuracy is a function of the POWER LVL drive signal from the A14 frequency control assembly and the ALC circuitry on A10. The vernier accuracy is specified at 300 MHz. Since vernier accuracy is tested using a broadband power sensor, abnormally high spurious responses could cause the measured vernier accuracy to fail when in fact the accuracy of the 300 MHz signal alone is within specification.

1. Check the POWER LVL drive signal from A14. Monitor A17J16 pin 1 with a DVM. Change the TRK GEN RF POWER in 1 dB steps and note the voltage at each power level setting. The voltage should change by the same amount for each 1 dB step. If the voltage does not change by the same amount for each 1 dB step, the fault lies on the A14 frequency control assembly.
2. Check for abnormally high spurious outputs. Connect the RF OUT 50 Ω to the input of another spectrum analyzer (the "test analyzer"). Set the test analyzer to sweep from 300 kHz to 2.9 GHz, with a sweep time of 100 msec or less. Set the HP 8560E/EC to sweep from 300 kHz to 2.9 GHz with a 50 second sweep time. Press **SGL SWP** on the HP 8560E/EC and observe any responses on the test analyzer,

ignoring the desired output signal. If any spurious responses are greater than -20 dBc, the vernier accuracy measurement may fail. Refer to "Harmonic/Spurious Outputs Too High" in this chapter.

3. Check for excessive LO feedthrough. Use the "LO Feedthrough" performance test in the *HP 8560 E-Series Spectrum Analyzer Calibration Guide*, but check over a center frequency range of 300 kHz to 100 MHz. The LO feedthrough will be 3.9107 GHz greater than the center frequency setting.

Harmonic/Spurious Outputs Too High

Harmonic and spurious outputs may be generated by A10 itself or may be present on either the 600 MHz drive or 1st LO drive signal. There is a direct relationship between spurious signals on the 1st LO and spurious signals on the TG output. There is a five-to-one relationship between spurious signals on the 600 MHz drive and the spurious signals on the TG output. For example, if the 600 MHz signal moves 1 MHz, the TG output signal will move 5 MHz. This is due to the multiplication in the pentupler.

1. If the "Harmonic Spurious Responses" performance test failed, connect another spectrum analyzer, such as an HP 8566A/B, to the HP 8560E/EC 1ST LO OUTPUT connector. Set the HP 8560E/EC to each frequency as indicated in the performance test, with the span set to 0 Hz. At each frequency setting, press **SGL SWP, CAL, MORE 1 OF 2, FREQ DIAGNOSE, LO FREQ**. The frequency displayed will be the fundamental frequency of the 1ST LO OUTPUT. Use the HP 8566A/B to measure the level of the second and third harmonics of the 1st LO signal.

NOTE

The 1st LO typically has a higher harmonic content than the tracking generator output. For the purposes of this check, it is the variation in harmonic content versus frequency which is important.

If the variation of the harmonic level of the 1st LO versus frequency tracks the harmonic level variation of the tracking generator output, repeat this step while measuring the 1st LO signal at the end of W43 nearest A10. If there is little variation in the 1st LO harmonic level between the 1ST LO OUTPUT connector and W43, and the relative variation in harmonic level tracks with the TG output harmonic level, suspect either the A7 LODA or A11 YTO.

If the harmonic level variation of the 1st LO versus frequency does not track the harmonic level variation of the TG output, suspect A10.

2. If sidebands are present at the same frequency offset at every output frequency, check the spectral purity of the 1st LO and the 600 MHz drive signals using another spectrum analyzer. When checking the 1st LO, the HP 8560E/EC must be set to zero span. Press **CAL, MORE 1 OF 2, FREQ DIAGNOSE, LO FREQ** to determine the 1st LO

frequency. A 1 MHz sideband on the 1st LO will appear as a 1 MHz sideband on the output signal.

To verify that the 600 MHz drive or 1st LO signal is responsible for the sidebands, substitute a clean signal for the 600 MHz drive or 1st LO signal. If the sidebands on the output disappear when using the clean signal, the substituted signal was responsible for the sidebands.

NOTE The 600 MHz drive signal should be -8 dBm \pm 3.5 dB. The 1st LO signal should be +16 dBm \pm 2 dB.

Power Sweep Not Functioning Properly

Power sweep is accomplished by stepping real time DAC #1 (R/T DAC1) which adds an offset to the POWER LVL signal. Refer to Function Block S of the A14 frequency control assembly schematic. R/T DAC1 is an 8-bit DAC and can provide power sweeps of up to 12.8 dB. This is equivalent to 0.05 dB per DAC step. Since R/T DAC1 has only 256 discrete settings but 601 points per sweep are digitized, up to three adjacent points per sweep may correspond to the same power level setting.

1. If the power sweep appears to be non-monotonic, the fault probably lies on the A3 interface assembly (real time DACs). To check the operation of R/T DAC1, monitor A3J400 pin 3 with an oscilloscope. Trigger the oscilloscope off the negative-going edge of the BLKG/GATE OUTPUT (rear panel) of the HP 8560E/EC. Set the power sweep range to 12.8 dB and tracking generator RF POWER to -10 dBm. Set the HP 8560E/EC SWEEPTIME to 50 ms. A 0 to +10 V ramp should be observed on the oscilloscope. The amplitude of the ramp should decrease approximately 780 mV for each 1 dB decrease in power sweep range.

NOTE Although power sweep range may be set to a 12.8 dB sweep width, the power sweep function is only warranted to have a 10 dB sweep width.

2. Perform the "Vernier Accuracy" performance test. If this test fails, refer to "Vernier Accuracy Out-of-Tolerance" in this chapter.

No Power Output

The A10 requires power supplies, a 1st LO signal, and a 600 MHz drive signal in order to provide power output.

1. Check power supplies on A14J13 and A10J1. Refer to the A14 frequency control assembly schematic.
2. Verify that the voltage at A14J17 pin 14 is greater than +14 Vdc. If the voltage is not greater than +14 Vdc, troubleshoot A14.

3. Check that ALC_EXT, measured at A17J13 pin 10, is at a TTL low when the TG is set to ALC INT and at a TTL high when the TG is set to ALC EXT.
4. Check that the 600 MHz drive signal is $-8 \text{ dBm} \pm 3.5 \text{ dB}$. If the signal is outside of this range, troubleshoot the A15 RF assembly.
5. Check that the 1st LO input signal is $+16 \text{ dBm} \pm 2 \text{ dB}$. Perform the "1ST LO OUTPUT Amplitude" performance test, measuring the level at the end of W43 nearest A10.
6. Check the tracking adjustment controls. Monitor A14J16 pin 13 with a DVM. On the HP 8560E/EC, use the step keys and numeric keypad to set the COARSE TRACK ADJ value from 0 to 255. The voltage measured should increase from 0 V to +10V.

Monitor A14J17 pin 13 with the DVM. Use the RPG knob to set the FINE TRACK ADJ value from 0 to 255. The voltage measured should increase from 0 V to +10V. Monitor A14J17 pin 15 with the DVM. The voltage at this point should change as both the FINE TRACK ADJ and COARSE TRACK ADJ values are changed; however the voltage change per step of the FINE TRACK ADJ will be much less (about one-sixtieth) than the voltage change per step of the COARSE TRACK ADJ.

7. If all of the checks above are correct, the tracking oscillator might not be functioning. Set up the HP 8560E/EC as indicated in the "Tracking Oscillator Range Adjustment" procedure, using a spectrum analyzer, such as an HP 8566A/B, in place of the frequency counter. Try to adjust A10C3 until a signal is displayed on the HP 8566A/B. If adjusting A10C3 does not start the tracking oscillator functioning, suspect the A10 tracking generator.

Figure 11-5 HP 8560E RF Section Troubleshooting Block Diagram

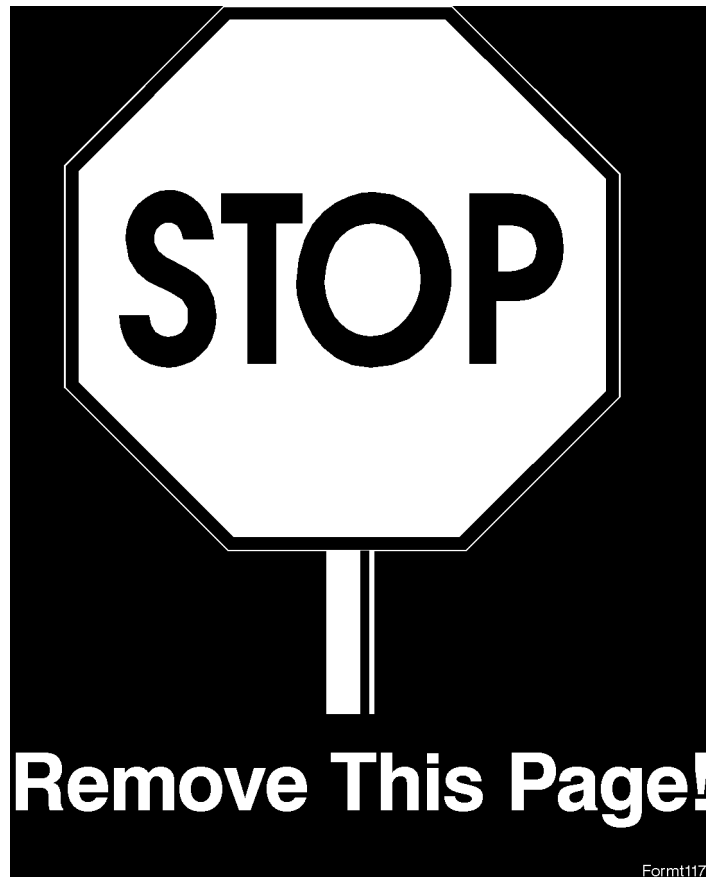

Replace with sj111c

12 **Display/Power Supply Section**

Introduction

The Display/Power Supply chapter consists of the following sections:

| | |
|--------------------------------|----------|
| A17 LCD Display (8560EC) | page 619 |
| A17 CRT Display (8560E)..... | page 624 |
| A6 Power Supply | page 638 |

WARNING

The A6 power supply in 8560 E-series and 8560 EC-series instruments, and the A6A1 high voltage assembly in 8560 E-series instruments, contain lethal voltages with lethal currents in all areas. Use extreme care when servicing these assemblies. Always disconnect the power cord from the instrument before servicing these assemblies. Failure to follow this precaution can represent a shock hazard which may result in personal injury.

The voltage potential at A6A1W3, in 8560 E-series instruments, is +9 kV. If the cable must be disconnected, always disconnect it at the CRT with caution! Failure to properly discharge A6A1W3 may result in severe electrical shock to personnel and damage to the instrument. See procedure 2 in Chapter 3.

Do not discharge the CRT second anode in 8560 E-series instruments directly to ground, with the A6A1 high voltage cable connected. This can damage the A17 CRT driver assembly. Always discharge through a high resistance, such as a high voltage probe.

Always use an isolation transformer when troubleshooting either the A6 power supply or the A6A1 HV module. When using an isolation transformer, connect a jumper between A6TP101 and A6TP301. This connects the circuit common to earth ground. Remove this jumper when the isolation transformer is not used.

LCD Display (8560EC)

The display section of 8560EC instruments contain the A17 display driver, the A17A1 inverter board, the A18 LCD (liquid crystal display), and the A6 power supply. The A6 power supply is explained in the power supply section which begins on page 590. [Figure 12-1 on page 620](#) illustrates the LCD block diagram.

| | |
|---|----------|
| Troubleshooting the LCD Display..... | page 621 |
| Blank Display | page 621 |
| Dim Display | page 622 |
| Troubleshooting using the VGA port | page 622 |
| Troubleshooting using part substitution | page 622 |

Figure 12-1 Simplified Section Block Diagram

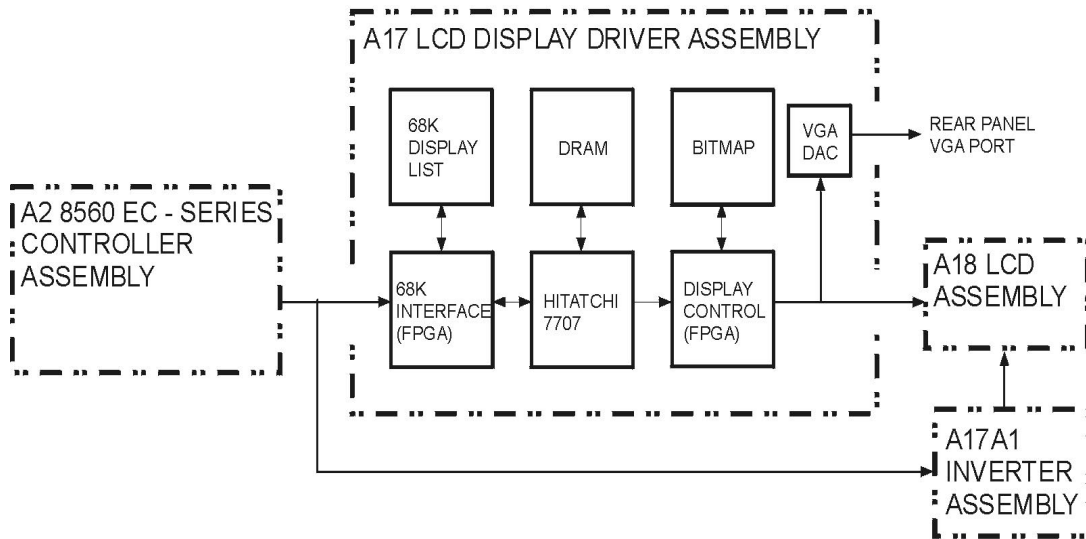

sj136c

Overview of A17 Display Driver Board

The A17 display driver board monitors the 8560 EC-series controller board, copies display instructions to local memory, creates a bitmap from the data, and generates the signals needed to drive the LCD display and a VGA monitor. The display driver consists of a Hitachi 7707 processor, an FPGA, DRAM, SRAM, a filter circuit, and a video DAC.

The FPGA is connected to the address bus, data bus, and the display memory control signals on the controller board. The FPGA monitors the control signals and determines when the Hitachi 7707 processor writes to display memory. When this occurs, the FPGA makes a duplicate of this information on the display driver board. The other main function of the FPGA is to provide the signals necessary to drive a TFT LCD display and a standard VGA monitor.

The processor reads display information received from the controller board, creates a bitmap, and copies the bitmap into SRAM. The FPGA outputs this information to the LCD and VGA displays. The DRAM is used by the processor to run its program. The filter circuit provides the clock signals that are needed to run the display driver board. The video DAC converts the digital color information that goes to the LCD to analog signals; these signals drive the RGB color lines on the VGA port.

Troubleshooting the LCD Display

NOTE There are no adjustments for intensity or contrast of the LCD.

Blank Display

1. If the LED above the front-panel LINE switch is lit, most of the A6 power supply is functioning properly.
2. Carefully check the voltages on the front-panel PROBE POWER jack. Be careful to avoid shorting the pins together. See [Figure 12-2 on page 621](#).
3. Check that the fan is operating. If the PROBE POWER voltages are correct, and the fan is turning, the A6 power supply is probably working properly.
4. If all of the power supply indicators along the outside edge of the A2 controller assembly are lit, the A6 power supply is probably working properly.
5. Connect a VGA monitor to the VGA port on the rear of the instrument. If the display is still blank, suspect the A2 controller, a loose cable, or the display driver.
6. If the LED is not lit, or the fan is not working, or the probe power voltages are not correct, or the power supply indicators on the edge of the A2 controller assembly are not working properly, proceed to the section on troubleshooting the power supply on [page 642](#).
7. Open the left side of the instrument (see procedure A2 on [page 150](#)). Make voltage measurements at pins 1, 2, 3, 4, 5, 41, 42, 43, 44, and 45 on J8 of the A2 controller (see [Figure 12-3 on page 623](#)). These pins should measure $5V \pm 0.25V$. If any of these measurements is out of tolerance suspect the A2 controller board or the power supply. If the voltages for these pins are correct, make the same measurements at the identical pins on J1 of the A17 display driver board. If these measurements are correct, suspect the A18 LCD assembly or the A17A1 inverter board. If these measurements are not correct, suspect the A17 LCD driver or A17A1 inverter board.

Figure 12-2 Probe Power Socket

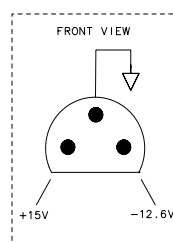

Dim Display

1. If the display is dim, suspect the backlights, which are inserted into the LCD assembly from the backlight assembly. Always replace both backlights at the same time. For the backlight replacement procedure, see [page 158](#).

Troubleshooting using the VGA port

1. Connect a VGA monitor to the rear VGA port of the instrument (the VGA port is always active and requires no user interaction).
2. Observe the display.

If the display on the VGA monitor is working correctly, the problem is probably caused by the LCD, or by a cable problem. Proceed to step 1 in “Troubleshooting using part substitution”.

If the display on the VGA monitor shows the same symptom(s) you have seen on the instrument’s LCD, the problem is probably caused by the A2 controller board, the display driver, or by a cable problem. Proceed to step 2 in “Troubleshooting using part substitution”. If you proceed past step 3, skip step 4.

Troubleshooting using part substitution

1. Disconnect the power cord, turn the instrument off, and open the left side. Ensure that W60, W61, W62, W63, and W64 are tight. Reconnect the power cord and check the instrument to see whether the problem is corrected. If not, proceed to step 2.
2. Disconnect the power cord and turn the instrument off. Replace W60, the ribbon cable that connects the A2 board to the display driver board. Reconnect the power cord and check the display to see whether the problem is corrected. If not, proceed to step 3.
3. Disconnect the power cord and turn the instrument off. Replace W61, the 10 MHz reference cable that connects the A2 board to the display driver board. Reconnect the power cord and check to see whether the problem is corrected. If not, proceed to step 4.
4. Disconnect the power cord and turn the instrument off. Remove and replace (see procedure 2A on [page 152](#)) the A17 display driver board. Reconnect the power cord and check the instrument to see whether the problem is corrected. If not, proceed to step 5.
5. Remove and replace (see procedure 5 on [page 172](#)) the A2 controller board. Check to see whether the problem is corrected. If not, proceed to step 6.
6. Disconnect the power cord and turn the instrument off. Remove and replace (see procedure 2A on [page 152](#)) the A18 LCD. Reconnect the power cord and check to see whether the problem is corrected.

Figure 12-3 Location of +5V supply pins on J1 of A17 and J8 of A2

| | | | |
|-------------|------|------|-------------|
| GND SX | ● 80 | ● 79 | addrmsx2 |
| addrmsx 3 | ● 78 | ● 77 | GND SX |
| addrmsx 6 | ● 76 | ● 75 | addrmsx 7 |
| GND SX | ● 74 | ● 73 | addrmsx 10 |
| addrmsx 11 | ● 72 | ● 71 | GND SX |
| NC | ● 70 | ● 69 | NC |
| 6ND SX | ● 68 | ● 67 | NC |
| NC | ● 66 | ● 65 | GND SX |
| NC | ● 64 | ● 53 | NC |
| GND SX | ● 62 | ● 61 | DATAMSX 2 |
| DATAMSX 3 | ● 60 | ● 59 | GND SX |
| DATAMSX 6 | ● 58 | ● 57 | DATAMSX 7 |
| GND SX | ● 56 | ● 55 | DATAMSX 10 |
| DATAMSX11 | ● 54 | ● 53 | GNSD SX |
| DATAMSX 14 | ● 52 | ● 51 | DATAMSX 15 |
| GND SX | ● 50 | ● 49 | NC |
| _RESETMSX | ● 48 | ● 47 | GND SX |
| NC | ● 46 | ● 45 | +5V BKLT SX |
| +5VBKLT SX | ● 44 | ● 43 | +5VBKLT SX |
| +5VBLKTSX | ● 42 | ● 41 | +5VSX |
| addrmsx 1 | ● 40 | ● 39 | GND SX |
| addrmsx 4 | ● 38 | ● 37 | addrmsx 5 |
| gnd sx | ● 36 | ● 35 | addrmsx 8 |
| addrmsx 9 | ● 34 | ● 33 | GND SX |
| addrmsx 12 | ● 32 | ● 31 | addrmsx 13 |
| GND SX | ● 30 | ● 29 | NC |
| NC | ● 28 | ● 27 | GND SX |
| NC | ● 26 | ● 25 | NC |
| GND SX | ● 24 | ● 23 | DATAMSX |
| DATAMSX 1 | ● 22 | ● 21 | GND SX |
| DATAMSX 4 | ● 20 | ● 19 | DATAMSX 5 |
| GND SX | ● 18 | ● 17 | DATAMSX 8 |
| DATAMSX 9 | ● 16 | ● 15 | GND SX |
| DATAMSX 12 | ● 14 | ● 13 | DATAMSX 13 |
| GND SX | ● 12 | ● 11 | LMUX-INSX |
| EN1SX | ● 10 | ● 9 | GND SX |
| NC | ● 8 | ● 7 | NC |
| GND SX | ● 6 | ● 5 | +5VBKLT SX |
| +5V BKLT SX | ● 4 | ● 3 | +5VBKLT SX |
| +5V BKLT SX | ● 2 | ● 1 | +5VSX |

sj114c

Figure 12-3 shows A2J8 connections on 8560 EC-series Instruments. Lines 2 –5 and 42 – 44 supply +5V to the two LCD backlights. Lines 1 and 41 supply +5V to the A17A1 Inverter board. Lines 1 – 6 and 41 – 44 are identical on A17J1.

CRT Display (8560E)

The CRT display section contains the A6 power supply, A6A1 HV module, A17 CRT driver, and A18 CRT. The A6 power supply and A6A1 HV module are explained in the section on the power supply which begins on page 590. [Figure 12-4 on page 625](#) illustrates the section block diagram.

| | |
|------------------------------------|--------------------------|
| Troubleshooting Using the TAM..... | page 626 |
| Blank Display (Using the TAM)..... | page 628 |
| Blank Display..... | page 629 |
| Blanking Signal..... | page 631 |
| Display Distortion..... | page 632 |
| Focus Problems..... | page 634 |
| Intensity Problems..... | page 636 |

WARNING

The A6 power supply and A6A1 high voltage assemblies contain lethal voltages with lethal currents in all areas. Use extreme care when servicing these assemblies. Always disconnect the power cord from the instrument before servicing these assemblies. Failure to follow this precaution can represent a shock hazard which may result in personal injury.

The voltage potential at A6A1W3 is +9 kV. If the cable must be disconnected, always disconnect it at the CRT with caution! Failure to properly discharge A6A1W3 may result in severe electrical shock to personnel and damage to the instrument. See procedure 2 in Chapter 3.

Do not discharge the CRT second anode directly to ground, with the A6A1 high voltage cable connected. This can damage the A17 CRT driver assembly. Always discharge through a high resistance, such as a high voltage probe.

Always use an isolation transformer when troubleshooting either the A6 power supply or the A6A1 HV module. When using an isolation transformer, connect a jumper between A6TP101 and A6TP301. This connects the circuit common to earth ground. Remove this jumper when the isolation transformer is not used.

Figure 12-4 Power Supply and CRT Block Diagram

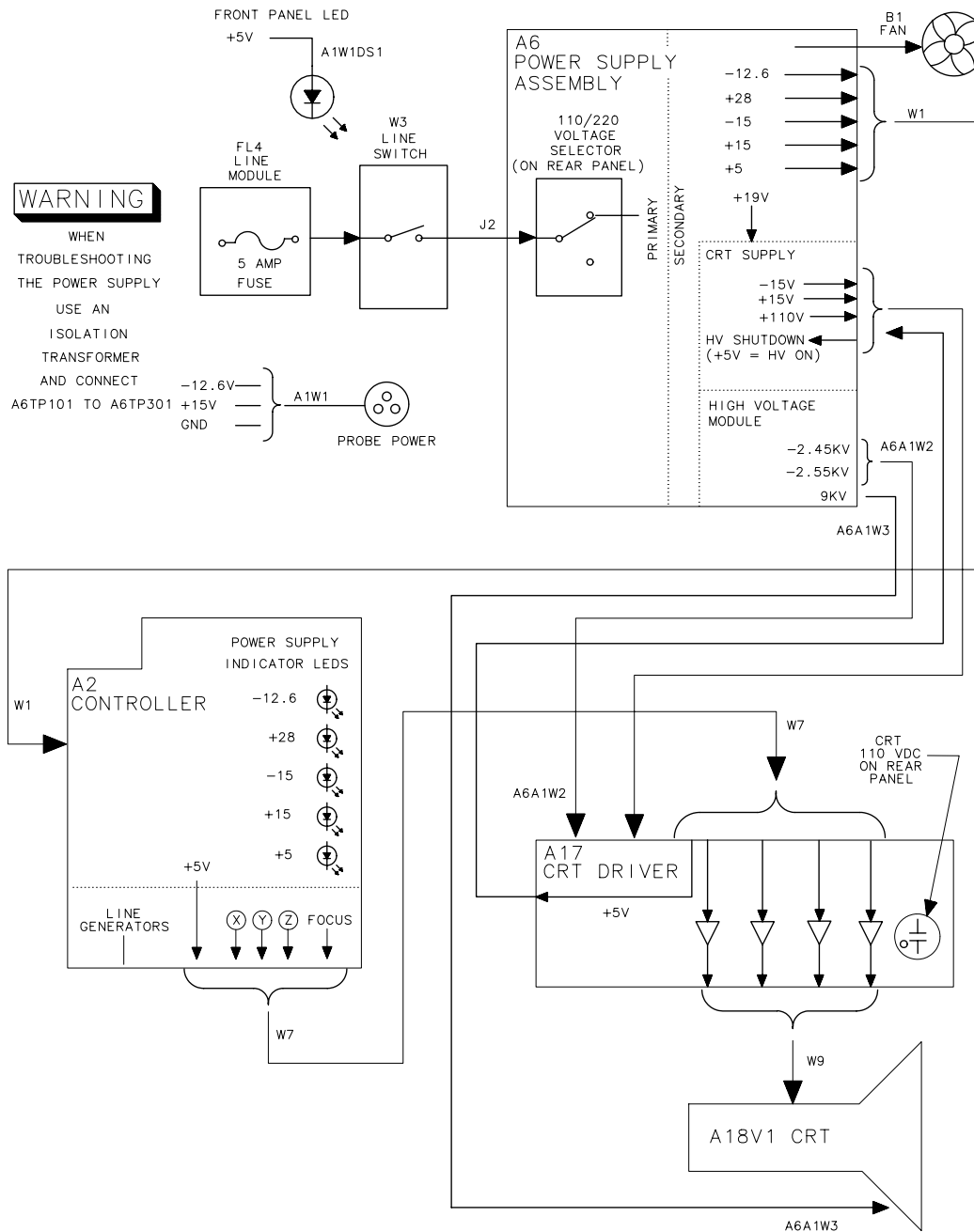

sp141e

Troubleshooting Using the TAM

When using automatic fault isolation, the TAM indicates suspected circuits that need to be manually checked. Use [Table 12-1 on page 626](#) to locate the manual procedure.

[Table 12-5 on page 627](#) lists assembly test connectors associated with each manual probe troubleshooting test. [Figure 12-5 on page 627](#) illustrates the location of A17 test connectors.

Table 12-1

Automatic Fault Isolation References

| Suspected Circuit Indicated by Automatic Fault Isolation | Manual Procedure to Perform |
|---|--|
| Check A2 Controller | Blanking Signal |
| Check All Power Supply Outputs | Dead Power Supply (<i>steps 1-5</i>) |
| Check Buck Regulator | Dead Power Supply (<i>steps 13-23</i>) |
| Check Buck Regulator Control Circuitry | Dead Power Supply (<i>steps 11-21</i>) |
| Check High-Voltage Supplies | High Voltage Supplies |
| Check Input Rectifier | Dead Power Supply (<i>steps 6-7</i>) |
| Check Intensity Adjustments | Intensity Problems (<i>steps 1-4</i>) |
| Check Kick Start/Bias Circuitry | Dead Power Supply (<i>steps 8-10</i>) |
| Check Low-Voltage Supplies | Low Voltage Supplies |

Figure 12-5 A17 Test Connector

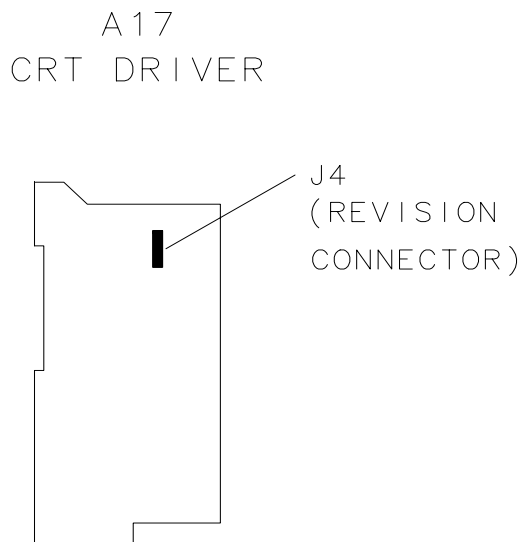

Table 12-2 TAM Tests versus Test Connectors

CK1101

| Connector | Manual Probe Troubleshooting Test | Measured Signal Lines |
|-----------|---|---|
| A17J4 | Revision Constant current Source Intensity input Intensity offset Blanking control | MS5 MS1 MS7 MS7 MS8 |
| A2J201 | 10 V reference test Switch drive test Buffered X & Y DAC outputs X line generator test Y line generator test Intensity offset output | MS4 MS3 MS2, MS7 MS6 MS1 MS8 |
| A2J202 | Revision X, Y, & Z output offset X output amplifier | MS1 MS3, MS4, MS7 MS7 |
| | Y output amplifier Blanking test Focus DAC test | MS3 MS4 MS2 |

Blank Display (Using the TAM)

Use the following procedure if the instrument display is blank. This procedure substitutes an HP-IB printer for the display.

1. Connect the printer to the HP 8560E spectrum analyzer and set the printer address to the value required by the TAM. This is usually 1.
2. All of the power-supply indicator LEDs along the edge of the A2 controller assembly should be lit.
3. The rear panel CRT +110 VDC ON indicator should also be lit.
4. Connect the TAM probe cable to A2J11.
5. Press **MODULE**, **SOFT KEY #3**, **▼**, and **SOFT KEY #1**. (The top soft key is #1.)
6. The yellow LED next to A2J11 should blink approximately ten times. If the LED fails to blink correctly, troubleshoot the digital section of the A2 controller assembly.
7. Move the probe cable to A2J202. Press **SOFT KEY #1** and wait 5 seconds.
8. Press **SOFT KEY #4**. The results should be sent to the printer.
9. Move the probe cable to A2J201, press **SOFT KEY #1** and wait 5 seconds.
10. Press **SOFT KEY #4**. The results will be sent to the printer.
11. If a failure is indicated in any of these tests, the fault lies on the A2 controller assembly. To obtain more information:
 - a. Press the down arrow key one less time than the test number. (For example, press it twice for the third test on the list.)
 - b. Press **SOFT KEY #3**, then **SOFT KEY #4**, and when the printout is complete, **SOFT KEY #6**.
12. If no failures were indicated in testing the A2 controller, move the probe cable to A17J4.
13. Press **SOFT KEY #1** and wait 5 seconds.
14. Press **SOFT KEY #4**. The results will be sent to the printer.
15. If no failure is indicated in the printout, check the high-voltage supplies as described "High Voltage Supplies" in this chapter.

Blank Display

1. If the LED above the front panel LINE switch is lit, most of the A6 power supply is functioning properly.
2. Carefully check the voltages on the front panel PROBE POWER jack. Be careful to avoid shorting the pins together. See [Figure 12-6 on page 629](#).
3. Check that the fan is operating. If the PROBE POWER voltages are correct, and the fan is turning, the A6 power supply is probably working properly.
4. If the CRT +110 VDC ON LED on the rear panel is lit, the high-voltage supplies should also be operating. (The high-voltage supplies will be turned off if the HV SHUT_DOWN line is low.) The A6 power supply feeds +5 V to the A2 controller through W1. The A2 assembly distributes this +5 V to the A17 CRT driver through W7. A17 sends +5 V back to A6 as the HV SHUT_DOWN signal on W8. As a result, A2, A17, W1, W7, and W8 must all be in place for the high-voltage supplies to operate.
5. If all of the power supply indicators along the outside edge of the A2 controller assembly are lit, the A6 power supply is probably working properly.

Figure 12-6 Probe Power Socket

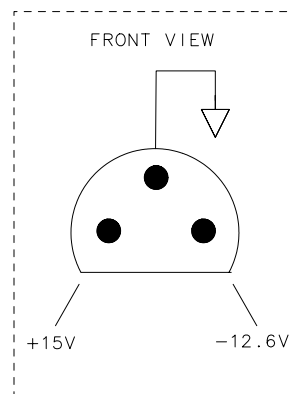

SK1122

6. Press **FREQUENCY, 1, GHz**.
7. Allow the analyzer to warm up for at least 1 minute.
8. While observing the display, press **LINE** to turn the spectrum analyzer off. If a green flash appears on the display, the CRT is probably working properly; troubleshoot either the A2 controller or the A17 CRT driver.
9. If a flash does not appear on the display, the A2 controller, A6A1 HV module, A17 CRT driver, or A18V1 CRT might be at fault.

Blanking Signal

1. Connect an oscilloscope probe to A2J202 pin 3. Connect the oscilloscope ground lead to TP3. Set the oscilloscope to the following settings:

Sweep time 2 ms/div
Vertical scale 1 V/div

2. If a 4 Vp-p signal is not observed, the A2 controller assembly is faulty.
3. Repeat steps 1 and 2 with the oscilloscope probe on A2J202 pin 14.
4. Set the oscilloscope to the following settings:
5. Connect the positive probe lead to A2J202 pin 15. This is the blanking output.
6. TTL-level pulses should be observed. If the signal is either always high or always low, the display will be blanked; suspect the A2 controller assembly.
7. If the signals on A2J202 pins 3, 14, and 15 are correct, troubleshoot the A17 CRT driver.

Display Distortion

The HP 8560E uses a vector display. The graticule lines, traces, and characters are composed of a series of straight lines ("vectors") placed end-to-end. If the vectors do not begin and end at the proper points, the display appears distorted, but in focus. Symptoms range from characters appearing elongated and graticule lines not meeting squarely, to an entirely unreadable display.

1. If the spectrum analyzer is in external frequency reference mode (an "X" is displayed along the left side of the display), ensure that an external 10 MHz reference is supplied. Otherwise the 16 MHz CPU clock will be off-frequency, causing distortion.
2. Use the CRT ADJ PATTERN to check for distortion. Press **CAL**, **MORE 1 OF 2**, and **CRT ADJ PATTERN**. If vector distortion (described above) occurs, perform the "Display Adjustment" in Chapter 2 to test the function of the A2 controller assembly.
3. If there is distortion along with slight focus degradation, but the graticule lines meet (not necessarily squarely), the A17 CRT driver, CRT, DDD/TRACE ALIGN adjustments, or cable connections might be at fault.
4. If the A2 controller assembly is not part number 08563-60017, perform the "16 MHz PLL adjustment" in Chapter 2. If the 16 MHz CPU clock is off-frequency, the display will be distorted.
5. Perform the "Display Adjustment" in Chapter 2. Isolate the problem to either the X or Y axis by noting the behavior of the adjustments. If the line generator or fast zero-span portion of the adjustment fails, troubleshoot the A2 controller assembly.
6. If the adjustments do not remedy the problem, press **LINE** to turn the spectrum analyzer off and place the A17 CRT driver in the service position.
7. Distortion confined to one axis (vertical or horizontal only), indicates a faulty X or Y deflection amplifier on the A17 assembly. Use the alternate good deflection amplifier for obtaining typical voltages. (There is enough symmetry in a typical display that the voltages should be similar between these circuits.)
8. Monitor the waveforms at A17TP11 and A17TP14 (or TP12 and TP13). The 50 to 100 Vp-p ac component of the waveforms at the X and X (or Y and Y) outputs should be mirror images of each other. The dc average should be 55 V.
9. The appropriate POSN adjustment (A17R57 or A17R77) should change the dc component of both X and X (or Y and Y) outputs in opposite directions.

10. The appropriate GAIN adjustment (A17R55 or A17R75) should change the ac component in both outputs by the same amount.
11. If the display is a single dot, check the base of A17Q18 for $-10.3 \text{ V} \pm 0.3 \text{ V}$. Verify the signals at TP11, TP14, TP12, and TP13.
12. If signals are correct and cables to the CRT are good, suspect the CRT.

Focus Problems

Focus problems may be due to a defective A18V1 CRT, the A17 CRT driver (especially the grid level shifter section), or the A2 controller focus control circuitry. Focus problems may also be due to improper adjustments, improper connections, or absence of high voltage.

Although A17 grid level shifter (function block D) is the leading cause of A17 focus problems, function blocks C, E, F, and H generally have less effect on focus, but may cause poor focus that is a function of screen position, length of line, or intensity.

1. Connect the positive lead of a DVM to A2J202, pin 2. Connect the negative lead to A2J202 pin 6.
2. Use the knob to change the focus DAC value from 0 to 255.
3. If the DVM reads near 0 Vdc with the focus set to 0, and near -10 Vdc with the focus set to 255, the A2 focus control circuitry is working properly.
4. Perform the "Display Adjustment" in Chapter 2. Note that A17R34 COARSE FOCUS has the greatest effect on focus. Adjustment A17R93 ASTIG and A17R92 DDD have a lesser effect, and A17R21 Z FOCUS, A17R26 X FOCUS and front panel adjustment (press **DISPLAY, MORE 1 OF 2, FOCUS**, and turn knob) have less effect on focus.
5. If the focus of some areas of the screen are worse than normal, continue with step 11. If no part of the screen can be brought to sharp focus, continue with step 6. (CRTs have some normal focus variation across their face.)
6. Turn off the analyzer and place A17 in the service position. Connect the ground lead of a high-voltage probe (HP 34111A) to the chassis, and use it with a DVM to measure A17J7(10).
7. The nominal A17J7(10) voltage is -1600 Vdc, but the CRT will function if this voltage is within 200 V of -1600 Vdc.
8. Adjusting A17R34 COARSE FOCUS should vary the A17J7(10) voltage by 150 V. If these voltages are correct, suspect the CRT.
9. Check the A6A1 high voltage module cathode supply output at A17TP16 using a high voltage probe. If the cathode voltage is -2450 V \pm 250 V, check the focus grid level shifter.
10. If the cathode voltage is not correct, check the A6A1 high voltage module and its connections.
11. Connect an oscilloscope probe to A17TP9. This signal corrects the focus for the X position of the CRT beam, and for intensity level. It also provides the front panel focus adjusting voltage.

12. Press **DISPLAY, MORE 1 OF 2**, and **FOCUS**. While turning the front panel knob, verify the dc level of the signal at TP9 adjusts about 30 Vp-p.
13. Verify that the front panel intensity adjustment, when used with the A17R21 Z FOCUS, changes the peak-to-peak voltage at TP9 by 25 V. Access the intensity adjustment by pressing **DISPLAY, INTENSITY**, and turning the front panel knob.
14. Set front panel intensity to minimum. Set A17R21 Z FOCUS and A17R26 X FOCUS fully counterclockwise. Verify that the peak-to-peak voltage at TP9 is about 40 Vp-p (due to X-dynamic focus circuit).
15. If circuit operation seems correct, the A18V1 CRT is probably at fault.

Intensity Problems

Intensity problems, or absence of display, can be due to the A17 assembly intensity amplifier (function block A), intensity grid level shifter (function block B), CRT (A18V1), interconnections, or lack of proper supplies or inputs to A17.

1. On the HP 8560E spectrum analyzer, press **DISPLAY** and **INTENSITY**.
2. Rotate the front panel knob (RPG), and check that the intensity changes from dim, but readable, to bright.
3. If the intensity function does not function properly, troubleshoot the A2 controller assembly.
4. Perform the preliminary and Z-axis portions of the "Display Adjustment" in Chapter 2. Verify that A17R11 CUTOFF functions properly. If A17R11 CUTOFF does not function properly, place the A17 CRT driver in the service position.
5. Verify that blanking pulses are present at A17TP2 using an oscilloscope. The pulses should be normal TTL levels, approximately 1 μ s wide and 4 or 7 μ s apart. If the blanking pulses are not correct, check the BLANKING output of the A2 controller assembly and cable W7.
6. If blanking pulses are present, check A17TP10 with the oscilloscope. The TP10 signal should vary with the front panel intensity adjustment, and be approximately 55 Vp-p maximum. The signal will be composed of both blanking pulses and varying intensity levels for the lines being drawn.
 - If a proper signal is not present at A17TP10, check A17Q1, Q2, CR1, and CR2.
 - If the TP10 signal does not vary with the front panel intensity adjustment, check the signals at A17TP4 and A17TP1. Both signals should vary with the front panel intensity adjustment. The TP4 signal should be up to 4 Vp-p, and the TP1 signal should be up to approximately 12 Vp-p.

WARNING

The A17 CRT Driver contains lethal voltages with lethal currents. Use extreme care when servicing this assembly. Always disconnect the power cord from the instrument before servicing this assembly. Failure to follow this precaution can present a shock hazard which may result in personal injury.

NOTE

The following measurements should be made with a high-voltage probe, such as the HP 34111A. When using the high-voltage probe, connect the ground lead securely to the HP 8560E chassis.

7. Carefully measure the grid voltage at A17J7 pin 6, and the cathode voltage at A17J7 pin 4. The display will work with a cathode voltage of $-2450\text{ V} \pm 250\text{ V}$, provided the grid voltage (A17J7 pin 6) is 30 to 100 V more negative than the cathode. A17R11, CUTOFF, should be able to adjust the voltage difference over a 60 V range to account for tube variations, and achieve proper intensity.
8. If the grid and cathode voltages are correct, turn off the HP 8560E spectrum analyzer and check A17CR10 with an ohmmeter. If A17CR10 is good, suspect the A18V1 CRT.
9. If the grid and cathode voltages are too low, turn off the power and disconnect W8 from the base of A18V1 CRT, and recheck the grid and cathode voltages.
10. If the grid and cathode voltages are still too low, refer to "CRT Supply" in this chapter and the "High-Voltage Power Supply Adjustment" procedure in Chapter 2.
11. If voltages are correct when the tube is disconnected, the CRT is probably defective.

CAUTION

The pins on the A18V1 CRT bend easily. Be careful not to bend pins when connecting W8 to A18V1.

Power Supply

The power supply section contains the A6 power supply and, in 8560E instruments, the A6A1 HV module. [Figure 12-7 on page 639](#) illustrates the power supply block diagram. [Table 12-3 on page 640](#) lists signal versus pin numbers for power cable W1.

| | |
|---|----------|
| A6 Power Supply Assembly | page 642 |
| Dead Power Supply | page 642 |
| Line Fuse Blowing | page 644 |
| Supply Restarting Every 1.5 Seconds (Kick Start) | page 644 |
| Low Voltage Supplies | page 644 |
| High Voltage Supplies (8560E only)..... | page 645 |
| CRT Supply Dropping Out (8560E only) | page 646 |
| Blanking Signal (8560E only)..... | page 647 |
| Buck Regulator Control | page 647 |
| DC-DC Converter Control | page 648 |
| Power Up | page 648 |

WARNING

The A6 power supply in 8560E and 8560EC instruments, and the A6A1 high voltage assembly in 8560E instruments, contain lethal voltages with lethal currents in all areas. Use extreme care when servicing these assemblies. Always disconnect the power cord from the instrument before servicing these assemblies. Failure to follow this precaution can represent a shock hazard which may result in personal injury.

The voltage potential at A6A1W3, in 8560E instruments, is +9 kV. If the cable must be disconnected, always disconnect it at the CRT with caution! Failure to properly discharge A6A1W3 may result in severe electrical shock to personnel and damage to the instrument. See procedure 2 in Chapter 3.

Do not discharge the CRT second anode directly to ground, with the A6A1 high voltage cable connected. This can damage the A17 CRT driver assembly. Always discharge through a high resistance, such as a high voltage probe.

Always use an isolation transformer when troubleshooting either the A6 power supply or the A6A1 HV module. When using an isolation transformer, connect a jumper between A6TP101 and A6TP301. This connects the circuit common to earth ground. Remove this jumper when the isolation transformer is not used.

Figure 12-7 Simplified Power Supply Block Diagram

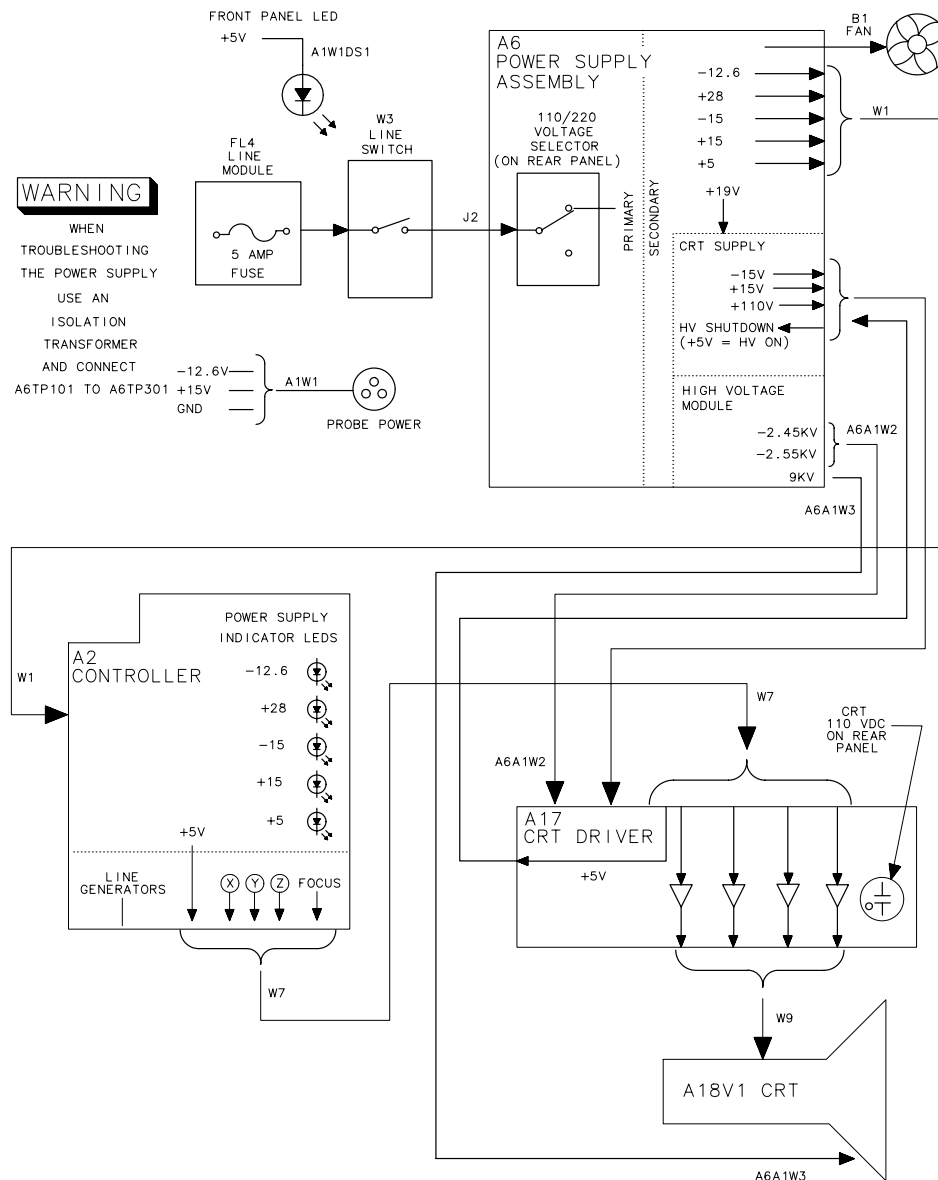

sp141e

NOTE

The block diagram in Figure 12-7 shows the power supply in an 8560E instrument. The power supply in 8560EC instruments is identical except that the CRT and high voltage supplies in an 8560EC are inactive, and are not connected to CRT circuitry.

Table 12-3 W1 Power-Cable Connections

| Signal | A2J1 (pins) | A3J1 (pins) | A4J1 (pins) | A5J1 (pins) | A6J1- (pins) | A14J1 (pins) | A15J1 (pins) |
|-----------|----------------|----------------|----------------|----------------|-----------------|-----------------|-----------------|
| NC | - | - | - | - | - | - | - |
| NC | - | - | - | - | - | - | - |
| A GND | - | 3 | 3 | 48 | 3* | 3 | 3 |
| NC | - | - | - | - | - | - | - |
| NC | - | - | - | - | - | - | - |
| A GND | - | 6 | 6 | 45 | 6* | 6 | 6 |
| NC | - | - | - | - | - | - | - |
| NC | - | - | - | - | - | - | - |
| A GND | - | 9 | 9 | 42 | 9* | 9 | 9 |
| SCAN RAMP | 41 | 10 | - | - | - | 10* | - |
| NC | - | - | - | - | - | - | - |
| A GND | - | 12 | 12 | 39 | 12* | 12 | 12 |
| -12.6 V | 38 | 13 | - | - | 13* | - | - |
| -15 V | - | 14 | 14 | 37 | 14* | 14 | 14 |
| A GND | - | 15 | 15 | 36 | 15* | 15 | 15 |
| -15 V | - | 16 | 16 | 35 | 16* | 16 | 16 |
| +15 V | - | 17 | 17 | 34 | 17* | 17 | 17 |
| A GND | - | 18 | 18 | 33 | 18* | 18 | 18 |
| +15 V | - | 19 | 19 | 32 | 19* | 19 | 19 |
| +28 V | - | 20 | - | - | 20* | 20 | 20 |
| +28 V | - | 21 | - | - | 21* | 21 | 21 |
| PWR UP | 29 | - | - | - | 22* | - | - |
| -15 V | - | 23 | 23 | 28 | 23* | 23 | 23 |
| -15 V | - | 24 | 24 | 27 | 24* | 24 | 24 |
| +15 V | - | 25 | 25 | 26 | 25* | 25 | 25 |
| +15 V | - | 26 | 26 | 25 | 26* | 26 | 26 |
| +5 V | - | 27 | 27 | 24 | 27* | 27 | 27 |
| +5 V | - | 28 | 28 | 23 | 28* | 28 | 28 |
| +5 V | - | 29 | 29 | 22 | 29* | 29 | 29 |
| +5 V | - | 30 | 30 | 21 | 30* | 30 | 30 |
| D GND | 20 | 31 | 31 | 20 | 31* | - | 31 |
| D GND | 19 | 32 | 32 | 19 | 32* | - | 32 |
| A GND | 18 | 33 | 33 | 18 | 33* | 33 | 33 |
| A GND | 17 | 34 | 34 | 17 | 34* | 34 | 34 |
| D GND | 16 | 35 | 35 | 16 | 35* | 35 | 35 |
| D GND | 15 | 36 | 36 | 15 | 36* | 36 | 36 |
| D GND | 14 | 37 | 37 | 14 | 37* | 37 | 37 |
| D GND | 13 | 38 | 38 | 13 | 38* | 38 | 38 |
| +5 V | 12 | 39 | - | - | 39* | - | - |
| +5 V | 11 | 40 | - | - | 40* | - | - |
| +5 V | 10 | 41 | - | - | 41* | - | - |
| +5 V | 9 | 42 | - | - | 42* | - | - |
| +5 V | 8 | 43 | - | - | 43* | - | - |
| +5 V | 7 | 44 | - | - | 44* | - | - |
| +28 V | 6 | 45 | - | - | 45* | - | - |
| LINE | - | 46 | - | - | 46* | - | - |
| TRIGGER | - | - | - | - | - | - | - |

* Indicates signal source.

Table 12-3 W1 Power-Cable Connections

| Signal | A2J1 (pins) | A3J1 (pins) | A4J1 (pins) | A5J1 (pins) | A6J1- (pins) | A14J1 (pins) | A15J1 (pins) |
|--------|-------------|-------------|-------------|-------------|--------------|--------------|--------------|
| +15 V | 4 | 47 | - | - | 47* | - | - |
| +15 V | 3 | 48 | - | - | 48* | - | - |
| -15 V | 2 | 49 | 49 | - | 49* | - | - |
| -15 V | 1 | 50 | 50 | - | 50* | - | - |

* Indicates signal source.

Troubleshooting Using the TAM (8560E only)

When using automatic fault isolation, the TAM indicates suspected circuits that need to be manually checked. Use [Table 12-4 on page 641](#) to locate the manual procedure.

Table 12-4 Automatic Fault Isolation References

| Suspected Circuit Indicated by Automatic Fault Isolation | Manual Procedure to Perform |
|--|--|
| Check A2 Controller | Blanking Signal |
| Check All Power Supply Outputs | Dead Power Supply (<i>steps 1-5</i>) |
| Check Buck Regulator | Dead Power Supply (<i>steps 13-23</i>) |
| Check Buck Regulator Control Circuitry | Dead Power Supply (<i>steps 11-21</i>) |
| Check High-Voltage Supplies | High Voltage Supplies |
| Check Input Rectifier | Dead Power Supply (<i>steps 6-7</i>) |
| Check Intensity Adjustments | Intensity Problems (<i>steps 1-4</i>) |
| Check Kick Start/Bias Circuitry | Dead Power Supply (<i>steps 8-10</i>) |
| Check Low-Voltage Supplies | Low Voltage Supplies |

A6 Power Supply Assembly

HP 8560E and 8560EC spectrum analyzers uses a switching power supply operating at 40 kHz to supply the low voltages for most of the analyzer hardware. In the 8560E, the power supply also provides a 30 kHz switching supply (CRT supply) for the high voltages used by the CRT display used in E-series instruments. The CRT supply will be treated as a separate supply since the remainder of A6 must be operating for the CRT supply to operate.

Kick starting occurs when there is a fault either on the power supply or on one of the other assemblies. The power supply will try to start by generating a 200 ms pulse ("kick") every 1.5 seconds. A kick-starting power supply often appears to be dead, but the fan will make one or two revolutions and stop every 1.5 seconds.

Dead Power Supply

1. Use an isolation transformer and connect a jumper between A6TP101 and A6TP301.
2. Connect the negative lead of a DVM to A6TP301.
3. Check TP308 for +5 V.
4. Check TP302 for +15 V.
5. Check TP303 for -15 V.
6. Check TP304 for +28 V.
7. Check TP305 for -12.6 V.
8. Measure the voltage at TP108 to verify the output of the input rectifier. The voltage should be between +215 Vdc and +350 Vdc.
9. If it is not within this range, check the rear panel fuse, input rectifier, input filter, and the rear panel line voltage selector switch.
10. Measure the voltage at TP206 to verify the output of the kick-start/bias-circuitry. The voltage should be approximately +14 Vdc. Test point 206 is on pin 1 of U203.
11. If there is no voltage at TP206, check TP210 for pulses 200 ms wide with an amplitude of 14.7 V. If there are no pulses present, the kick-start circuitry is probably defective. If the pulses are low in amplitude (about 1 V), Q201 is probably shorted.
12. If there are pulses at TP206, or there are pulses at TP210, but not at TP206, the buck regulator control circuitry is probably faulty.
13. Disconnect the power cord from the HP 8560E spectrum analyzer.
14. Connect the positive output of a current-limited dc power supply to

- the cathode of A6CR201 (TP206) and the ground to A6TP201.
15. Set the current limit of the power supply to about 500 mA and the voltage to 12 Vdc.
 16. Make sure a jumper is connected from A6TP101 to A6TP301. This independently powers the buck regulator control circuitry.
 17. Connect a jumper from the output of a +12 Vdc power supply to the end of A6R202 physically nearest A6C211.
 18. Connect a jumper from +12 Vdc to the end of C207 nearest C209.
 19. If the current draw exceeds approximately 50 mA, suspect a short in the buck regulator control circuitry or a shorted CR201.
 20. Check TP204 for an 80 kHz sawtooth (4 Vp-p).
 21. Check TP203 and TP207 for 40 kHz square (12 Vp-p). If the waveforms at either TP203 or TP207 are bad, one of the FETs in the DC-DC Converter is probably defective.
 22. Check TP105 and TP106 for a 12 Vp-p sawtooth waveform that is flattened at the bottom. If the waveform is a squarewave, the FET to which the test point is connected has failed or shorted.
 23. Check TP202 for 80 kHz pulses (12 Vp-p).
 24. Short TP401 to TP102. Check TP103 for a waveform similar to that in [Figure 12-8 on page 643](#).
 25. If the waveform at TP202 is correct but the waveform at TP103 is bad, suspect either Q102 or CR106.

Figure 12-8 **Buck Regulator Waveform**



sk 1

Line Fuse Blowing

1. If the line fuse blows with the LINE switch in the off position, suspect either the input filter or the power switch cable assembly.
2. If the line fuse blows when the HP 8560E/EC spectrum analyzer is turned on, disconnect the power cord and lift the drain of A6Q102 from TP108. If the line fuse still blows, suspect CR102 through CR105.
3. If the fuse is not burned out, check A6TP108 for a voltage of between +215 V and +350 V.
4. If the voltage at TP108 is correct, disconnect the power cord. Wait 60 seconds for the high voltage to discharge. Remove and check A6Q102.
5. If Q102 is shorted, Q103, Q104, CR106, and CR108 are also probably shorted. If Q102 is working properly, measure the resistance between TP102 and TP101 (positive ohmmeter lead to TP102).
6. If the resistance is less than 1 k Ω , suspect either Q103 or Q104 in the DC-DC Converter.

Supply Restarting Every 1.5 Seconds (Kick Start)

See function blocks G, H and L of A6 power supply schematic diagram in the component-level information binder.

If there is a short on the power supply or on one of the other assemblies, the power supply will attempt to "kick start." (Every 1.5 seconds the supply will attempt to start, but will be shut down by a fault condition.) The kick start and bias circuits provide power for the control circuitry during power-up. The kick start circuitry is an RC oscillator which emits a 200 ms pulse every 1.5 seconds. These pulses switch current from the Input Rectifier through Q201 to charge C201. When the power supply is up, a winding on T103 provides power to the control circuitry. This voltage is high enough to keep Q201 turned off.

1. Monitor the waveforms at TP206 and TP208 simultaneously on an oscilloscope.
2. If the signal at TP208 goes high before the signal at TP206 goes low, an overcurrent condition has been detected. Suspect a short in the secondary (output rectifier, voltage regulators, or another assembly).

Low Voltage Supplies

1. Connect the negative lead of a DVM to A6TP301.
2. Check A6TP302 for +15 Vdc.
3. Check A6TP303 for -15 Vdc.

4. Check A6TP304 for +28 Vdc.
5. Check A6TP305 for -12.6 Vdc.
6. Check A6TP308 for +5 Vdc.
7. If the voltages measured above are correct but the power supply LEDs on the A2 controller assembly are not lit, check W1.
8. If the voltages are low, disconnect W1 from A6J1 and measure the test point voltages again. Unless a dummy load is connected to the A6 power supply, the voltages should return to their nominal voltages but be unregulated.
9. If the voltages do not return to near their nominal range, the A6 power supply is probably at fault.
10. If the +5 V supply is low, suspect the +5 V regulator or the feedback circuit. To check the feedback circuit, measure the voltage of the +5 V reference (U305 pin 6) and the ± 5 V references to the voltage regulators (U306B pin 7 and U306D pin 14).
11. Check output of U306A pin 1. If the feedback circuit is working properly, the output of U306A should be near +13 Vdc.
12. Check output of U302; its output should be high if the feedback circuit is working properly.

High Voltage Supplies (8560E)

1. Press **LINE** to turn spectrum analyzer off, disconnect the power cord, and remove the power supply shield.
2. Connect the negative lead of a DVM to A6TP401 and positive lead to A6TP405.
3. Press **LINE** to turn spectrum analyzer on.
4. If the voltage displayed on the DVM is approximately +110 Vdc and the rear panel CRT +110 VDC ON indicator is lit, the A6A1 HV module is probably at fault.

NOTE

Ideally, the DVM should read the voltage written on the label of the A6A1 HV module. If necessary, perform the "High Voltage Power Supply" adjustment in Chapter 2.

5. If the DVM does not read approximately +110 Vdc, measure the voltage on A6U401 pin 10. This is the HV_SHUT_DOWN signal and should be near +5 Vdc.
6. If HV_SHUT_DOWN is low, suspect a bad connection along W8 between the A6 power supply and the 17 CRT driver.
7. If HV_SHUT_DOWN is correct, connect an oscilloscope to A6TP402. Connect the scope probe negative lead to TP401. Set the oscilloscope

to the following settings:

Sweep time 10 μ s/div
Vertical scale 10 V/div

8. A nearly-sinusoidal waveform, greater than 30 Vp-p, with an approximately +18 Vdc offset, should be observed.
9. If the waveform is a dc voltage near 0 Vdc with narrow, positive- and negative-going pulses, the A6A1 HV module is faulty. If the waveform is a dc voltage near +18 Vdc with narrow, positive- and negative-going pulses, connect the probe to TP403.
10. If the waveform at TP403 is a sawtooth waveform with a 1.8 V amplitude, the A6A1 HV module is faulty.
If the TP403 waveform has pulses similar to those on TP402, the A6 power supply is probably faulty.

CRT Supply Dropping Out (8560E)

See function block K of A6 power supply schematic diagram in the component-level information binder.

The CRT supply is a separate switching supply which provides the +110 Vdc for the A17 CRT driver from a winding on the A6A1 HV module. The CRT supply operates at approximately 30 kHz. The exact frequency is determined by the inductance of the primary winding of A6A1T1 and A6C407. The supply will only operate if the HV_SHUT_DOWN line is high.

If the power supply keeps dropping out, there is probably a short on the A17 CRT driver assembly.

1. Disconnect W8 from A6J4.
2. Connect an IC clip to U401 and connect a jumper between U401 pin 10 and TP308 (+5 Vdc).
3. Connect voltmeter to TP405 and press **LINE** to turn the analyzer on.
4. Check TP405 for a voltage of approximately +110 Vdc. It will probably measure higher since there is no load on the supply.
5. If the voltage at TP405 is correct, suspect a short on A17. If the voltage at TP405 is not correct, check U401 pin 8 for a sawtooth signal. The sawtooth should be flat-topped and about 5 Vp-p at a frequency of about 30 kHz.
6. If the sawtooth is not flat-topped, suspect U402A and its associated circuitry.
7. If the sawtooth is correct, check the base of Q401 for 30 kHz pulses.
8. If the duty cycle is high, but there is no +110 Vdc, suspect the bridge rectifier, CR401 through CR404.

Blanking Signal (8560E)

1. Connect an oscilloscope probe to A2J202 pin 3. Connect the oscilloscope ground lead to TP3. Set the oscilloscope to the following settings:

Sweep time 2 ms/div
Vertical scale 1 V/div

2. If a 4 Vp-p signal is not seen, the A2 controller assembly is faulty.
3. Repeat steps 1 and 2 with the oscilloscope probe on A2J202 pin 14.
4. Set the oscilloscope to the following settings:

Sweep time 1 μ s/div
Vertical scale 2 V/div

5. Connect the positive probe lead to A2J202 pin 15. This is the blanking output.
6. TTL-level pulses should be observed. If the signal is either always high or always low, the display will be blanked; suspect the A2 controller assembly.
7. If the signals on A2J202 pins 3, 14, and 15 are correct, troubleshoot the A17 CRT driver.

Buck Regulator Control

See function block H of the A6 power supply schematic diagram in the component-level information binder.

The buck regulator control pulse-width modulates the buck regulator and provides a synchronized signal to the DC-DC converter control circuitry. The buck regulator control has two feedback paths. The first is the output of the buck regulator, which provides coarse regulation. The second is the feedback circuit which samples and compares the +5 Vdc output of the output rectifier.

U202B and associated circuitry senses the output of the input rectifier and will turn off U203 if the voltage at TP108 is less than approximately +170 Vdc. Also, it will not allow U203 to start up until this voltage exceeds +215 Vdc. A low on the output of U202B will also clear the overcurrent latch in the DC-DC converter control circuitry.

Thermal shutdown occurs when RT201, mounted on the main heatsink, reaches a temperature of 100 C. When this occurs, the voltage at U203 pin 13 exceeds 0.6 V and inhibits pulses to the buck regulator.

R203, R204, U211, and associated circuitry provide feedforward for U203. This makes the loop gain independent of input line voltage and cancels 120 Hz ripple by more than 10 dB.

U202C and its associated circuitry permit the power supply to start up

at low line voltages at low temperatures. At low line voltages U202C will draw charge away from C206 through R205. This allows the buck regulator to turn on and draw current through the thermistors in the input rectifier. This warms up the thermistors, thereby decreasing their resistance and increasing the voltage at TP108. When the voltage is sufficiently high at TP108, the output of U202C will open and C206 will be allowed to charge normally.

U202A converts the sawtooth at TP204 to a squarewave to drive the DC-DC Converter Control circuitry. The frequency of the sawtooth is determined by the resistance at pin 7 of U203 and the capacitance at pin 8 of U203.

DC-DC Converter Control

See function block I of A6 power supply schematic diagram in the component-level information binder.

The DC-DC converter control circuitry divides the 80 kHz squarewave from U202A and generates two complementary 40 kHz squarewaves to drive the FETs in the DC-DC converter. Also, U202D and its associated circuitry monitor the voltage across sense resistor R116 in the DC-DC converter. When the current through the FETs in the DC-DC converter exceeds 1.8 A, the voltage across R116 will cause the output of U202D to go high. This sets a latch in U204 which turns off U203.

Power Up

See function block M of the A6 power supply schematic diagram in the component-level information binder.

The power up circuitry generates the PWR UP signal, which tells the microprocessor that the supplies are up and stable. PWR UP will go high when the +5 Vdc supply exceeds +4.99 Vdc. PWR UP will go low when this voltage is less than +4.895 Vdc. Once PWR UP is set low, it will stay low for at least 50 ms before going high, even if the +5 Vdc supply exceeds +4.99 Vdc before 50 ms have elapsed.

Figure 12-9 **A17 CRT Driver Block Diagram**

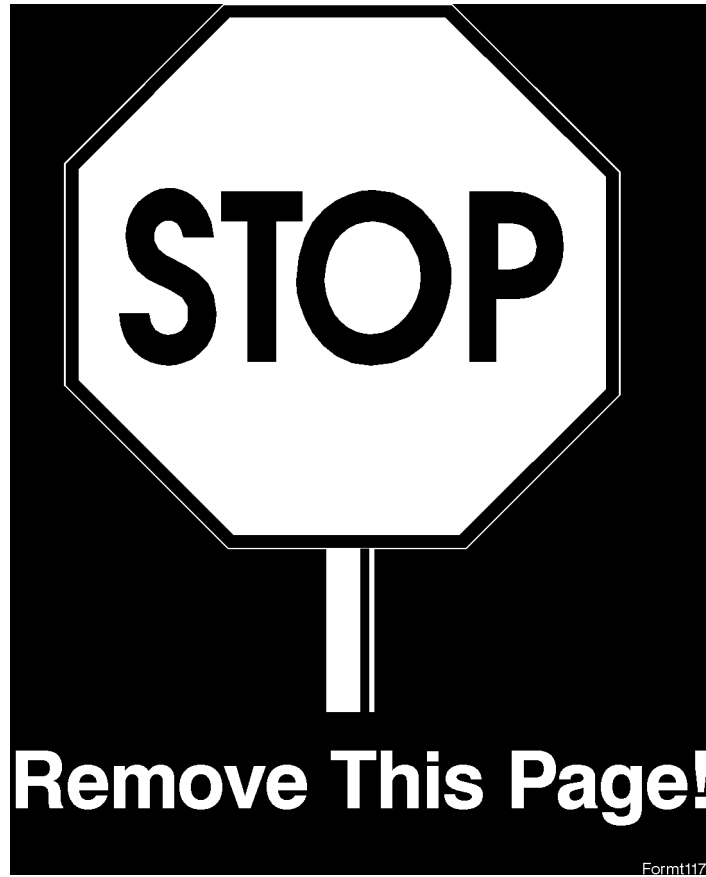

Replace with sj129c

Figure 12-10 **A6 Power Supply Block Diagram**

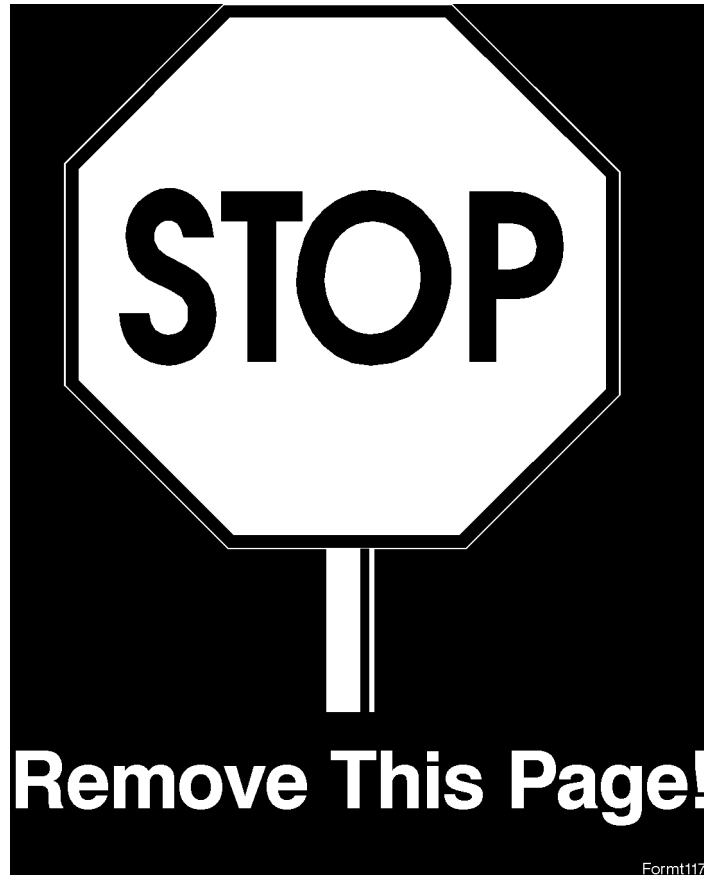

Replace with sj121c

13

**Component-Level Information
Packets**

Introduction

Information for repairable assemblies is provided in Component-Level Information Packets (CLIPs). Each CLIP contains a parts list, component-location diagram, and schematic diagram. Each CLIP has a part number that is changed whenever the related instrument assembly is changed.

Updated or replacement CLIPs may be ordered through your local Agilent Technologies Sales or Service Office. Use the CLIP part numbers provided in Table 14-1.

A single volume CLIP set that contains all repairable assemblies for the 8560 E-series and EC-series is also available. Order this CLIP set by using part number 5967-8582.

With the exception of the A2 controller board, the A1A1 keyboard, and the A17 CRT Driver board, the E-series assemblies for which CLIPs have been generated are identical to the same assemblies in EC-series instruments.

Each of the CLIPs in the CLIP set can be ordered individually.

NOTE

CLIPs may be unavailable for recently introduced assemblies.

Table 13-1 CLIPs Available for HP 8560E and 8560EC Spectrum Analyzers

| Board Assembly | Instrument Serial Prefix | Assembly Part Number | CLIP Part Number |
|---|--------------------------|--------------------------|------------------|
| A1A1 Keyboard (E-series) | 3611A and above | 08562-60140 | 08562-90188* |
| A1A1 Keyboard (EC-series only) | New Assembly | 08563-60162 | 08563-90222* |
| A2 Controller Assembly (EC-series only) | New Assembly | 08563-90160 | 08563-90224* |
| A2 Controller Assembly (E-series only) | 3213A through 3305A | 08563-60017 | 08563-90055 |
| | 3310A through 3329A | 08563-60032 | 08563-90074 |
| | 3331A through 3410A | 08563-60065 | 08563-90101 |
| | 3416A through | 08564-60010 [†] | 08563-90003 |
| | 3743A and above | 08564-90025 | 08564-90028* |
| A3 Interface Assembly (E-series, non-Option 007) | 3213A through 3337A | 08563-60021 | 08563-90056 |
| | 3350A through 3515A | 08563-60069 | 08563-90102 |
| | 3517A and above | 08563-60078 | 08563-90117 |
| A3 Interface Assembly (E-series, Option 007) | 3310A through 3337A | 08563-60033 | 08563-90075 |
| | 3350A through 3515A | 08563-60070 | 08563-90103 |
| | 3517A and above | 08563-60078 | 08563-90117 |
| A3 Interface Assembly (E- and EC-series) | 3611A and above | 08563-60098 | 08563-90017* |
| A4 Log Amplifier/Cal Osc | 3213A through 3246A | 08563-60025 | 08563-90057 |
| | 3301A through 3406A | 08563-60050 | 08563-90082 |
| | 3410A through 3514A | 08563-60074 | 08563-900900 |
| | 3515A through | 08563-60076 [†] | 08563-90114 |
| | 3728A and above | 08563-60103 | 08563-90166* |
| A5 IF Filter | 3213A through | 08563-60023 | 08563-90058 |
| | 3724A and above | 08563-60123 | 08563-90186* |
| [†] Denotes refurbished board assemblies available. Refurbished board assembly part numbers have 9 as the second digit of the suffix. For example, 08563-69032 is the refurbished part number for board assembly 08563-60032. [‡] Same as for A15 Option 103 with SIG ID. * Denotes current version of assembly. | | | |

Table 13-1 CLIPs Available for HP 8560E and 8560EC Spectrum Analyzers

| Board Assembly | Instrument Serial Prefix | Assembly Part Number | CLIP Part Number |
|---|--------------------------|---------------------------|------------------|
| A6 Power Supply | 3213A through 3310A | 08563-60020 | 08563-90059 |
| | 3327A through 3350A | 08563-60064 | 08563-90100 |
| | 3406A through | 08564-60008 [†] | 08564-90004 |
| | 3611A and above | 08564-60031 [†] | 08564-90039* |
| A6A2 Power Supply Regulator Board | 3818A and above | 08564-60030 | 08564-90034* |
| A14 Frequency Control | 3821A and above | 08563-60088 | 08560-90152* |
| A15 RF Board (Option 103) (with SIG ID) | 3213A through 3221A | 08563-60010 | 08563-90062 |
| | 3240A through 3304A | 08563-60035 | 08563-90068 |
| | 3305A through 3432A | 08563-60045 | 08563-90072 |
| | 3436A through 3450A | 08563-60055 | 08563-90111 |
| | 3514A through 3517A | 08563-60082 | 08563-90121 |
| | 3551A through | 08563-60085 [†] | 08563-90128 |
| | 3821A and above | 08563-60133 | 08563-90200* |
| A15 RF Board (Option 103) (without SIG ID) | 3305A through 3432A | 08563-60043 | 08563-90070 |
| | 3436A through 3450A | 08563-60055 [‡] | 08563-90111 |
| | 3514A through 3517A | 08563-60082 [‡] | 08563-90121 |
| | 3551A through | 08563-60085 ^{†‡} | 08563-90128 |
| | 3821A and above | 08563-60133 [‡] | 08563-90200* |
| A15 RF Board (Standard) (with SIG ID) | 3213A through 3221A | 08563-60016 | 08563-90062 |
| | 3240A through 3304A | 08563-60036 | 08563-90068 |
| | 3305A through 3432A | 08563-60046 | 08563-90072 |
| | 3436A through 3450A | 08563-60056 | 08563-90111 |
| | 3514A through 3517A | 08563-60083 | 08563-90121 |
| | 3551A through | 08563-60086 [†] | 08563-90128 |
| | 3821A and above | 08563-60134 | 08563-90201* |
| [†] Denotes refurbished board assemblies available. Refurbished board assembly part numbers have 9 as the second digit of the suffix. For example, 08563-69032 is the refurbished part number for board assembly 08563-60032. [‡] Same as for A15 Option 103 with SIG ID. * Denotes current version of assembly. | | | |

Table 13-1 CLIPs Available for HP 8560E and 8560EC Spectrum Analyzers

| Board Assembly | Instrument Serial Prefix | Assembly Part Number | CLIP Part Number |
|--|---------------------------------|-----------------------------|-------------------------|
| A15 RF Board (Standard) | 3305A through 3432A | 08563-60044 | 08563-90071 |
| | 3436A through 3450A | 08563-60054 | 08563-90110 |
| | 3514A through 3517A | 08563-60081 | 08563-90120 |
| | 3551A through | 08563-60084 [†] | 08563-90127 |
| | 3821A and above | 08563-60132 | 08563-90199* |
| A16 Fast ADC (Option 007 in E-series instruments only) | 3310A and above | 08563-60030 | 08563-90076* |
| A17 LCD Driver (EC-series) | New Assembly | 08563-60161 | 08563-90221* |
| A17 CRT Driver (E-series) | 3213A through | 08562-60165 | 08562-90187 |
| | 3221A through 3432A | 08562-60166 | 08562-90193 |
| | 3442A through | 08563-60077 [†] | 08563-90113 |
| | 3741A and above | 08563-60122 | 8563-90182* |
| A19 HP-IB | 3213A and above | 08562-60042 | 08562-90115* |
| [†] Denotes refurbished board assemblies available. Refurbished board assembly part numbers have 9 as the second digit of the suffix. For example, 08563-69032 is the refurbished part number for board assembly 08563-60032. * Denotes the current version of assembly. [‡] Same as for A15 Option 103 with SIG ID. | | | |

Figure 13-1 **HP 8560 EC-Series Interconnect Block Diagram**

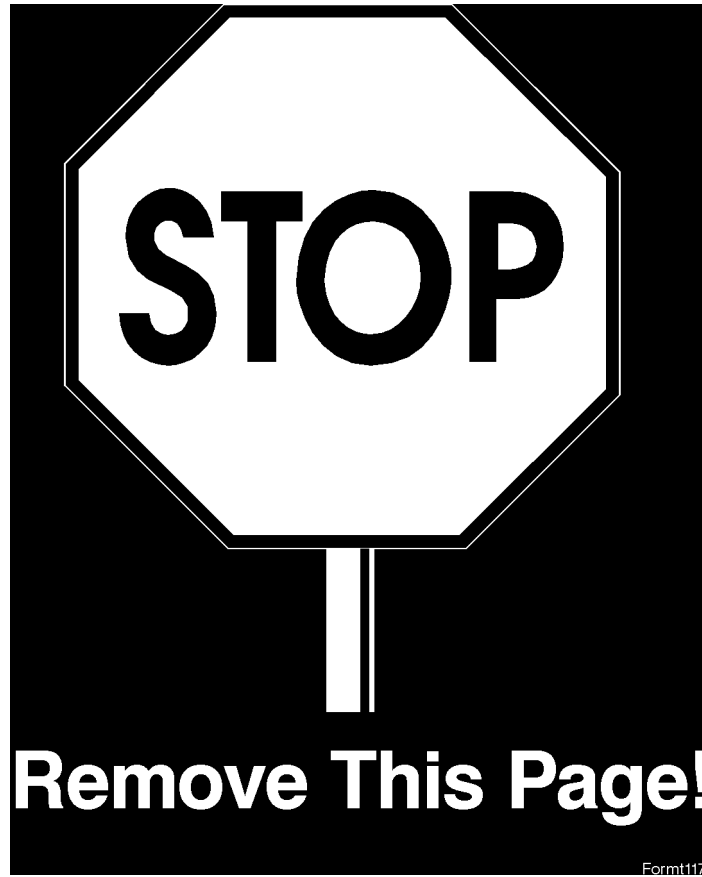

Replace with sj15c

Figure 13-2 **HP 8560 E-Series Interconnect Block Diagram**

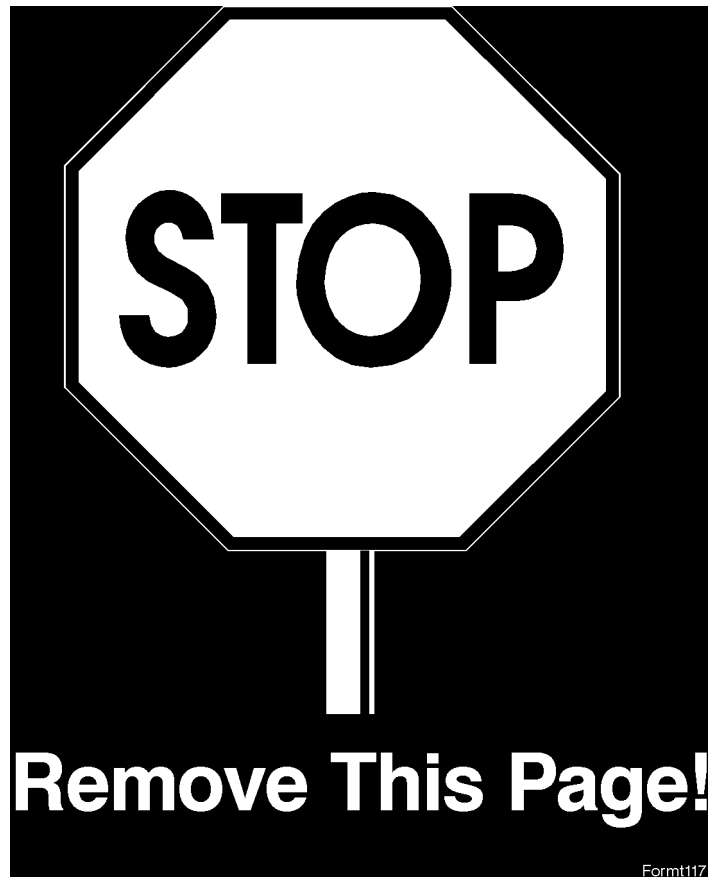

Replace with e1abe083

Numerics

1 MHz resolution bandwidth problems, 445
10 kHz and 3 kHz resolution bandwidth problems, 448
10.6925 MHz VCXO troubleshooting, 428
10.7 MHz and 4.8 kHz IF filter troubleshooting, 427
10.7 MHz IF filter troubleshooting, 426
100 MHz oscillator, 524
100 MHz VCXO, 524
3 kHz and 10 kHz resolution bandwidth problems, 448
30 kHz resolution bandwidth problems, 447
300 Hz to 3 kHz resolution bandwidth problems, 453
4.8 kHz and 10.7 MHz IF filter troubleshooting, 427
4.8 kHz IF filter troubleshooting, 426
600 MHz oscillator, 529

A

A2, A3, A4, and A5 removal, 171
replacement, 172
A4 limiter phase adjustment, 141
A4 linear amplifier failures, 422
A4 linear fidelity adjustment, 141
A4 log amplifier troubleshooting, 421
A4 log fidelity adjustment, 143
A5 IF assembly problems, 432
A6 power supply replacement, 180, 182
accessories, 233
ADC troubleshooting, 378
adjustment procedures
10 MHz Reference adjustment, 103
1ST LO distribution amplifier adjustment, 91
cal oscillator amplitude, 76, 135
calibrator amplitude adjustment, 101
demodulator adjustment, 105
external mixer amplitude adjustment, 110
external mixer bias adjustment, 108
frequency response adjustment, 97
high voltage power supply adjustment, 60

IF bandpass adjustment, 70
sampling oscillator adjustment, 84
Signal ID oscillator adjustment, 114
YTO adjustment, 87
adjustment procedures general information, 50, 58
adjustable components table, 54
factory selected components, 52
related adjustments table, 52
safety considerations, 51
TAM test equipment information, 57
TAM test equipment list, 58
TAM vs. manual adjustments, 58
using TAM, 57
adjustments recommended test equipment, 133

AFI

synthesizer, 516

AM/FM demodulator

troubleshooting, 425, 460

analog bus drivers

troubleshooting, 385

analog bus timing, 386

audio amplifier troubleshooting, 460

automatic IF adjustment, 415
automatic IF adjustment parameters, 416

B

blank display, 471, 621
blanking, 476
blanking signal, 631

C

cables, 173, 177
cal oscillator amplitude (A4R826) range troubleshooting, 452
low-pass filter troubleshooting, 459
troubleshooting, 450
unlock at start of IF adjust, 451
unlock conditions troubleshooting, 451
CAL OUTPUT, 526, 532
center frequency, harmonic number, 556
character problem, 483
chassis parts, 241, 249
controller block diagram, 501

cover assembly parts, 241, 249
cover removal/replacement, 149
CRT driver, 340
removal, 160
CRT, 160
CRT display, 624
CRT, simplified block diagram, 625
CRT, troubleshooting using the TAM, 626

D

DC log amplifier adjustments, 139
demodulator troubleshooting, AM/FM, 425
detector/mixer troubleshooting, 430
digital signature analysis microprocessor, 474
display blank, 471
jumbled, 478
line variations, 483
problems, 475
display section, 340

E

error codes
200 to 299, 301
error messages, 299, 328
10 MHz reference 336, 310
600 MHz reference loop error messages 333 to 335, 309
accessory module error messages 800 to 899, 327
ADC error messages 600 to 651, 324
amplitude error message 582, 322
automatic IF error messages 400 to 599, 312
battery error message 718, 326
cal unlock error message 499, 317
digital and checksum errors 700 to 799, 324
EEROM checksum error messages 700 to 704, 324
eliminating error messages, 299
fast ADC error 760, 327
fractional N PLL error message 337, 310
microprocessor error message 717, 326

- model number error message
719, 326
 - option modules error messages
800 to 899, 327
 - programmed ROM error
messages 705 to 710, 325
 - programming errors 100 to 150,
300
 - RAM check error messages 711
to 716, 325
 - roller oscillator error messages
321 to 329, 307
 - roller PLL errors 302 to 316, 303
 - sampling oscillator error
message 355, 311
 - span accuracy calibration error
messages 356 to 361, 311
 - system error messages 750 to
759, 326
 - user generated error messages
900 to 999, 327
 - YTO loop error message 331,
309
 - YTO loop error messages 300 to
316, 302
 - YTO loop error messages 317 to
318, 307
 - YTO loop settling error
messages 351 to 354, 310
- F**
- FADC Circuits (Option 007)
 - 8-bit flash ADC, 389
 - control word, 389
 - GAINX2, 389
 - peak/pit detection, 389
 - RAM, static, 389
 - video input section, 389
 - FADC Control Circuits (Option
007)
 - circular address, 389
 - clock sample, 389
 - comparator, 389
 - control registers, 389
 - control word, 389
 - counter, 389
 - CPU, 389
 - post-trigger counter, 389
 - reference check, 389
 - reference generator, 389
 - trigger, 389
 - video trigger, 389
 - firmware-dependent part
numbers, 227
 - first LO span problems, 559
 - flatness control troubleshooting,
367
- FM coil, 545**
- fractional N**
- divider, 553
 - oscillator, 538
 - phase noise, 562
 - span problems, 559
 - troubleshooting, 511
- fractional N PLL, 548**
- unlocked, 547
- frequency control block diagram,
575**
- frequency control, block diagram,
571**
- frequency counter, 489, 491**
- frequency counter**
- prescaler/conditioner
troubleshooting, 425
- frequency-count marker
problems, 487, 488**
- front frame**
- removal, 160
- front frame parts, 245, 255, 257**
- front frame(EC), assembly, 150**
- G**
- general information
 - ESD requirements, 41
 - HP 8560E options information,
27
 - HP sales and service offices, 46
 - packaging material part
numbers, 44
 - returning instruments for
service, 43
 - serial number label description,
29
 - graticule problem, 483
- H**
- harmonic number versus center
frequency, 556
- I**
- IF adjustment, automatic, 416
 - IF amplitude adjustments, 134
 - IF assembly troubleshooting, 415,
432
 - IF filter troubleshooting, 10.7
MHz, 426
 - IF filter troubleshooting, 4.8 kHz,
426
 - IF filter troubleshooting, 4.8 kHz
and 10.7 MHz, 427
 - IF filter, 4.8 kHz and 10.7 MHz
problems, 427
- IF gain uncertainty performance
test failures, 419**
- IF parameters adjusted, 416**
- IF section general**
- troubleshooting, 406
- IF signature problems, 441**
- IF signature troubleshooting, 433**
- input switch problems, 428**
- intensity problems, 482**
- interface strobe troubleshooting,
387**
- isolation amplifier problems, 430**
- K**
- keyboard
problems, 360, 500
 - keyboard
, 169
- L**
- LCD (EC), assembly, 150
 - LCD, display, 619
 - LCD, simplified block diagram,
620
 - LCD, troubleshooting the, 621
 - limiter phase adjustment, 141
 - limiter problems, 429
 - line generator, 475, 479
 - line switch (E), assembly
, 210
 - line switch (EC), assembly, 153
 - linear amplifier troubleshooting,
422
 - linear fidelity adjustment, 141
 - lines dim, 483
 - LO distribution amplifier, 538
 - LO span problems, 559
 - LO switch troubleshooting, 428
 - LODA, 538
 - log amplifier
 - detector/mixer troubleshooting,
430
 - failures, 421
 - input switch troubleshooting,
428
 - isolation amplifier
troubleshooting, 430
 - limiter troubleshooting, 429
 - troubleshooting, 421
 - log expand troubleshooting, 371
 - log fidelity adjustment, 143
 - log gain compensation
troubleshooting, 430
 - log offset compensation
troubleshooting, 430
 - log offset troubleshooting, 371
 - low band mixer, 591

low-pass filter troubleshooting, 459

M

main chassis parts, 241, 249
main coil, 546
manufacturers code list, 227
marker problems, 487, 488
mechanical parts, 241, 249
mixer/detector log amplifier troubleshooting, 430

O

OCXO, 574
offset lock loop, 534
offset PLL phase noise, 562
option 908, 233
option 909, 233
ordering information, 225

P

packaging, 43, 45
 packaging part numbers, 44
part ordering, 225
peak detectors troubleshooting, 374
performance test failures troubleshooting, 419
performance tests
 recommended test equipment list, 45
phase locked loops, 520
phase noise
 fractional N, 562
 int/ext reference, 562
 locked spans, 561
 offset PLL, 562
 problems, 561
 unlocked spans, 561
 YTO, 562
PLL locked at wrong frequency, 520
postscaler, 535, 548
power cable connections, 620
power supply, 638
 cover, 209
 replacement, 180, 182
 section, 340
power supply (E), assembly, 181
power supply (EC), assembly, 178
power supply warning, 619
power supply, simplified block diagram, 639
prescaler, 535

preselector peaking, 366
probe power socket, 621
programming errors, 300

R

rack slide kit, 233
real time DAC, 366
rear dress panel
 removal, 205
 replacement, 207
rear frame, 259
 removal, 205
 replacement, 207
rear frame parts, 245
reference divide chain, 535
reference PLL
 phase noise, 562
 unlocked 100 MHz VCXO, 524
 unlocked 600 MHz SAWR, 529
related adjustments table, 52
removal, front frame, 160
removal, front panel, 169
removal, power supply (E), 181
removal, power supply (EC), 178
replacement, front panel, 169
resolution bandwidth
 1 MHz problems, 445
 3 kHz and 10 kHz problems, 448
 30 kHz problems, 447
 300 Hz to 3 kHz problems, 453
resolution bandwidth
 performance test failures, 420
RF block diagram, 573, 577, 579
RF gain DACs, 367
RF parts, 241
RF section parts, 253
rosenfell detector troubleshooting, 377
RPG
 problems, 360
RPG, assembly, 170

S

sampler, 563
sampler IF, 543, 563
sampler troubleshooting, 512
sampling oscillator, 534, 538
sampling oscillator adjustment, 84
SAWR, 529
scale fidelity performance test failures, 420
serial numbers, 29
shipping
 shipping container, 43, 45

Signal ID oscillator adjustment, 114

span

>20 MHz, 556
2 MHz, 559
2.02 MHz to 20 MHz, 557
span accuracy problems, 555
span problems, 556, 559
speaker troubleshooting, 460
state storage problems, 499
step gains troubleshooting, 449
surface acoustic wave resonator, 529
sweep generator, 565, 568
sweep generator troubleshooting, 460
sweeping, 333
 span accuracy, 555
 YTO, 539
synthesizer section, 508
simplified block diagram, 570
troubleshooting, 514

T

TAM

automatic fault isolation, 516
controller troubleshooting, 471
error messages, 298
RF section connectors, 516
synthesizer section, 515, 516
troubleshooting A4 section, 409
troubleshooting A5 section, 409
troubleshooting the cal oscillator assembly, 413
troubleshooting the IF section, 408

TAM adjustments, 57, 58

adjustment indicators, 57
TAM vs. manual adjustments, 58

test equipment information, 57
test equipment list, 58

test and adjustment module controller, 471

test equipment list, 133

third LO driver amplifier, 528, 533

trace storage problems, 499

triggering problems, 363

troubleshooting

10 MHz reference 336, 310
600 MHz reference loop error messages 333 to 335, 309
accessory module error messages 800 to 899, 327
ADC error messages 600 to 651, 324

- amplitude error message 582, 322
 - automatic IF error messages 400 to 599, 312
 - battery error message 718, 326
 - cal unlock error message 499, 317
 - digital and checksum errors 700 to 799, 324
 - EEROM checksum error messages 700 to 704, 324
 - eliminating error messages, 299
 - error messages, 298
 - fast ADC error 760, 327
 - fractional N PLL error message 337, 310
 - microprocessor error message 717, 326
 - model number error message 719, 326
 - option module error messages 800 to 899, 327
 - programmed ROM error messages 705 to 710, 325
 - programming errors 100 to 150, 300
 - RAM check error messages 711 to 716, 325
 - roller oscillator error messages 321 to 329, 307
 - roller PLL errors 302 to 316, 303
 - sampling oscillator error message 355, 311
 - span accuracy calibration error messages 356 to 361, 311
 - system error messages 750 to 759, 326
 - user generated error messages 900 to 999, 327
 - viewing multiple error messages, 299
 - YTO loop error message 331, 309
 - YTO loop error messages 300 to 316, 302
 - YTO loop error messages 317 to 318, 307
 - YTO loop settling error messages 351 to 354, 310
 - troubleshooting error messages, 298
 - troubleshooting, blank CRT, 628
 - troubleshooting, blank LCD, 621
 - troubleshooting, blanking signal, 631
 - troubleshooting, blown line fuse, 644
 - troubleshooting, CRT focus, 634
 - troubleshooting, CRT intensity, 636
 - troubleshooting, dead power supply, 642
 - troubleshooting, dim LCD, 622
 - troubleshooting, display distortion, 632
 - troubleshooting, high voltage supplies, 645
 - troubleshooting, kickstarting, 644
 - troubleshooting, low voltage supplies, 644
 - troubleshooting, the LCD, 621
- U**
- unlocked PLL, 521
 - user generated error messages, 327
- V**
- VCO, 549
 - VCO bias voltages, 552
 - VCXO troubleshooting, 10.6925 MHz, 428
 - video circuits troubleshooting, 369
 - video filter troubleshooting, 372
 - video gating problems, 363
 - video MUX troubleshooting, 372
 - video mux troubleshooting, 431
 - video offset troubleshooting, 423
 - voltage tuned oscillator, 549
- W**
- W1 power-cable connections, 620
 - wire assembly cables, 233
- Y**
- YTO
 - FM coil span problems, 557
 - main coil span problems, 556
 - phase noise, 562
 - sweeping, 539
 - troubleshooting, 511
 - YTO PLL
 - unlocked, 538
- Z**
- zero-span problems, 486