

Keysight Technologies

Solutions for Wireless Handset Battery Drain Characterization

Maximize battery operating time without
jeopardizing your schedule

Solution Brochure



Your mission:
Wring every last bit of energy out of your wireless handset batteries

Common problems

- You need to more quickly conduct exhaustive testing:
You need to thoroughly test the impact of design and algorithm changes and validate complex customer use models, but you've got 2 month's worth of testing to accomplish in a 1-week test schedule.
- You need better insight:
To squeeze the most operating time out of your battery, you need to understand clearly how your handset manages its battery energy, both overall and within individual subcircuits.
- You need to better model real-world use profiles:
When you validate battery operating times, you need to ensure your tests reflect realistic user experience.

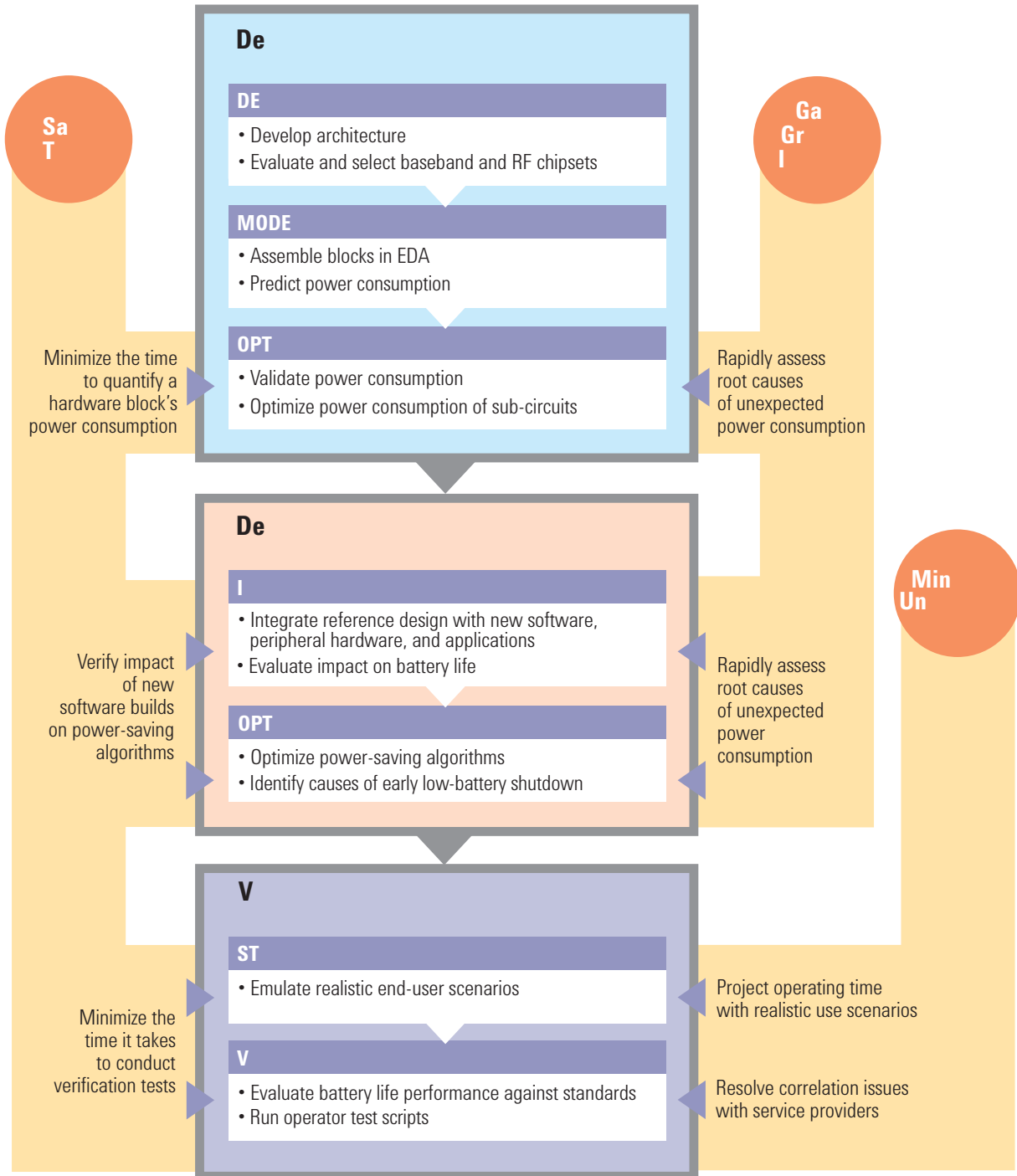

Here's what you can do with Keysight solutions for wireless handset battery drain characterization

Meet your schedule with more confidence

- Reduce time spent conducting battery drain tests
- Reduce delays getting an expert programmer to automate tests

Gain greater insight from battery drain characterization tests

- More thoroughly assess your power-saving algorithm's true effectiveness
- More accurately quantify how individual circuits affect overall operating time
- More easily identify root causes of overloads that trigger early low-battery shutdown

Validate battery operating times for realistic user experiences

- More easily create realistic user-experience scenarios for 3G, 4G, data applications and simultaneous user activities
- Ensure measurements aren't affecting actual results
- More accurately assess the true battery capacity delivered
- More quickly clear up uncertainties when you validate low-battery shutdown

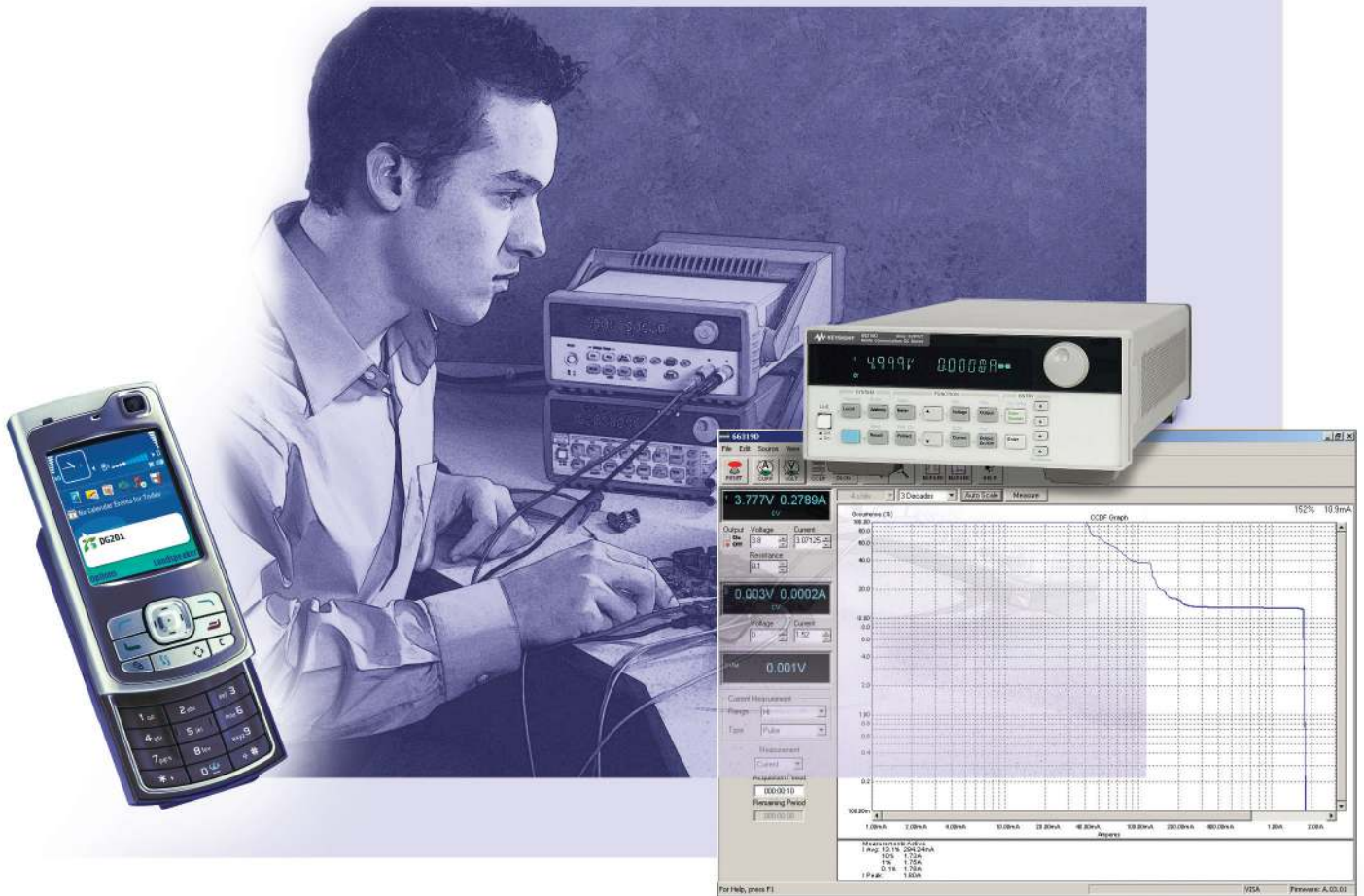

Problem 1

You need to conduct exhaustive testing on a very tight schedule

You need to thoroughly test the impact of design and algorithm changes, but making manual software-regression and design-validation tests can take weeks. You could set up a system under program control, but that requires a huge programming effort.

Solution: Automate tests with much less effort...

...using Keysight's integrated, modular software

14565B device characterization software with test automation

Key capabilities:

- Can be automated from most other programs (including E6568C Wireless Test Manager, N5970A/71A interactive functional stress test software, Keysight Technologies, Inc. VEE, and NI LabVIEW) and programming environments to combine measurements with device control and stimulus
- Named time stamps can be inserted into the current drain data log under program control to associate with device stimulus
- Works exclusively with 66319/21 DC sources to create a long-term continuous battery drain measurement solution

E6568C Wireless Test Manager software

Key capabilities:

- Lets you quickly build automated tests with minimum effort
- Developer's version allows you to create custom test steps
- Works with E5515C wireless communications test set and 14565B software

N5970A UMTS and N5971A CDMA interactive functional test software

Key capabilities:

- Functionally tests 3G and 4G devices with realistic user experiences
- Lets you test multiple simultaneous DUT activities
- Supports testing SMS, MMS and FTP data services and more
- Automatically generates test script code from GUI
- Works with E5515C wireless communications test set and 14565B software
- Generates battery drain log markers for DUT stimuli

To learn more

Visit our application-specific web site:

Battery Power Management for Portable Electronic Devices Web page
www.keysight.com/find/currentdrain

Check out these related application notes:

Wireless Mobile Device Design Validation: Accelerate Your Testing with Automated Test Solutions

Automating Keysight 14565B Battery Drain Measurements with National Instruments LabVIEW Interactive Functional Stress Software: Battery Current Drain Solutions for Cellular Devices

Take a closer look at information on these related products:

14565B software

E6568C WCDMA/GSM/GPRS/EGPRS Wireless Test Manager software

N5970A/71A UMTS/CDMA interactive functional stress test software

Case Study 1: Handset OEM eliminates time-consuming manual testing

Problem

A major handset OEM needed to validate battery drain for a series of RF functional setting combinations. This proved to be cumbersome and time consuming:

- It took weeks to manually set up thousands of test conditions
- A full-time operator was required for the entire test period
- The in-house battery drain test solution required on-going support from the internal test team, as setup and software were neither robust nor user-friendly

Solving the problem

With the 14565B battery drain software driver pre-integrated into Keysight's E6568C Wireless Test Manager (WTM) software, it was easy for the OEM to automatically set up and execute a suite of battery drain tests including all combinations of RF parameters. WTM served as the test executive, controlling and receiving measurements from the E5515C wireless communications test set and 66319D DC source. The OEM quickly constructed a test plan for performing fully automated tests, with all results logged and saved for post-test recall and analysis.

Results

Since switching from using the manual in-house battery drain characterization platform to Keysight's automated solution, operator assistance dropped from full time to 10%. Characterizing current drains for all combinations of channels and power levels, which used to take up to a week, now only takes a couple hours to set up and run to completion without further intervention.

Additional benefits included:

- No need for an expert to run the custom in-house solution
- New tests quickly and easily configured
- Other sites use the Keysight solution and it's now easy to correlate results

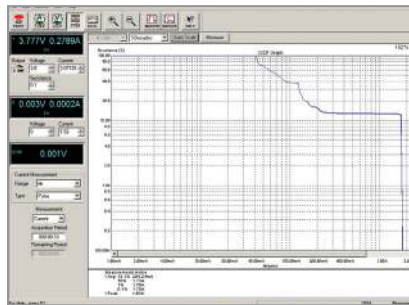

“How will these Keysight solutions save me money?”

- Eliminate man-years of expert programming and system engineering required to develop and support your own custom solution
- Shorten validation and regression testing from weeks or months to free up valuable resources and shorten your test schedule
- Uncover hidden problems earlier in development, when they're easier to resolve and at a fraction of the cost of fixing them in the field

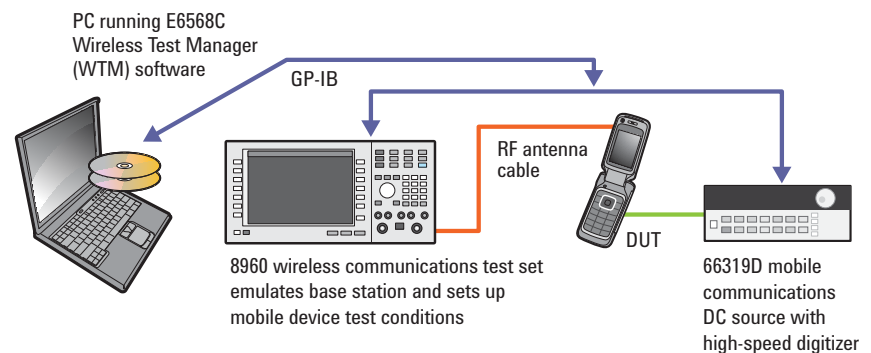

Talk to an expert

Get answers to your questions about conducting battery drain tests. Call 1 800 829-4444.

Get a quote: www.keysight.com/find/qq

Problem 2

You need better insight

To improve the operating-time performance of your design, you need a clearer understanding of how handset sub-circuits make use of the energy supplied by the battery. However, existing in-house and commercially available solutions provide only basic, generic capabilities that do not give you the insight required to optimize battery consumption.

Solution: More rapidly quantify the impact of changes to your sub-circuit design and power-saving algorithms...

...using Keysight's graphical visualization and analysis tools

66319D and 66321D mobile communications DC sources

Key capabilities:

- Accurate μA to A level ranging measurement system
- High-speed DSP-based digitizing measurement system

14565B device characterization software with test automation

Key capabilities:

- Works exclusively with 66319/21 DC sources to create a long-term continuous battery drain measurement solution with no programming required
- CCDF statistical profiling concisely quantifies amplitude levels, durations, and net contributions for analyzing power savings algorithms and subcircuit activities.
- Lets you save and recall CCDF profiles to quantify details and overall impact of design changes.
- Data logging tracks and identifies anomalous brief peaks of current draw leading to early low-battery device shutdown
- Programmable, time-stamped data log markers correlate current drain to DUT stimulus

E5515C wireless communications test set

Key capabilities:

- Supports most wireless formats. Firmware upgrades allow flexibility to add new/emerging formats and enhancements
- Full suite of features for setting DUT into any desired operating condition to measure battery drain under

To learn more

Visit our application-specific web site:

Battery Power Management for Portable Electronic Devices Web page
www.keysight.com/find/currentdrain

Check out these related application notes:

Battery Drain Analysis Improves Mobile Device Operating Time

Take a closer look at information on these related products:

14565B software

66300 Series mobile communications DC sources

E5515C wireless communications test set

Case Study 2: Handset OEM quickly extends standby battery operating time

Problem

A handset OEM wanted to extend standby battery operating time, which is critically important to its customers. To do so, it needed to thoroughly optimize the discontinuous receive (DRX) operation in its new handset. However, optimizing DRX is a complex task that requires tradeoffs between how quickly the receiver and related circuits can be awakened and put into sleep mode versus how deeply they can be put to sleep. To maximize power savings, the OEM needed to see details of current drain as circuits were activated and put into sleep mode. The OEM's existing current drain solution provided only basic measurement of average power consumption over an extended time.

Solving the problem

The OEM used a Keysight E5515C wireless communications test set for RF stimulus, a Keysight 66319D mobile communications DC source for DC power and current drain measurement, and Keysight 14565B software for visualization and analysis of the current drain results. With this turn-key solution, the OEM was finally able to see details of current drain as circuits woke up and went back to sleep and was able to quickly evaluate and optimize power savings for DRX operation.

Results

The OEM improved its new handset design for both DRX-off and active conditions and quickly optimized power savings by quantifying individual contributions as design changes were made. Ultimately, the OEM reduced power consumption by 84% and increased standby time from about a day to close to 1 week!

“What new capabilities will I get?”

- Insight, not just data: The 14565B software and 66319B/D and 66321B/D DC sources together are a tailored solution for battery drain characterization giving you measurements in real time and meaningful insights without data overload.
- Realistic use profiling: The N5970A/71A software and E5515C wireless communications test set work together to create tests that accurately reflect how your customers actually use wireless data applications.
- Modularity plus integration: The 14565B, E6568C, and N5970A/71A are all independent software products that can be used individually or with other software. They are also pre-integrated to provide you with a turnkey battery drain characterization platform from the start.

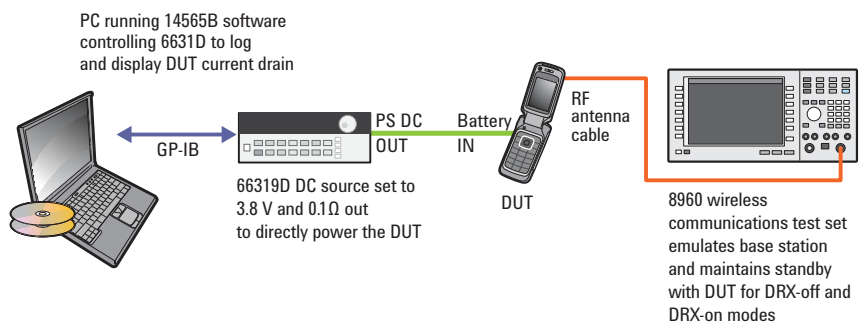
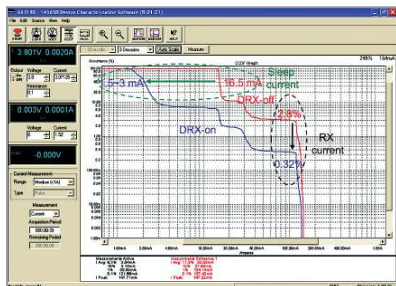
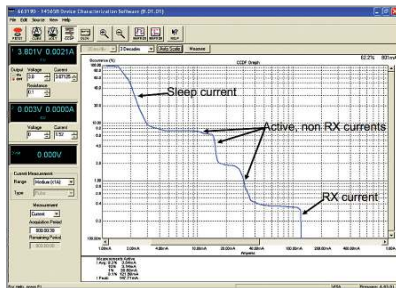

Talk to an expert

Get answers to your questions about getting the insight you need for minimizing battery consumption and optimizing operating time. Call 1 800 829-4444.

Get a quote: www.keysight.com/find/qq

Problem 3

You need to better model real-world use profiles

You encounter numerous uncertainties and complications when you attempt to verify battery run-down times for various user scenarios. For example, does testing use modes separately and adding the results provide the same answer as running these use modes together, like your customer may actually do? When you validate battery operating times, you need to reduce the impact of such uncertainties by applying real-world use cases.

Solution: More easily create device operating conditions that model realistic user experiences...

...with Keysight's flexible, real-world emulation tools for 3G and 4G

66319D and 66321D mobile communications DC sources

Key capabilities:

- Accurate μA to A level ranging measurement system
- High-speed DSP-based digitizing measurement system
- Zero-burden current shunt mode for battery run-down test
- DVM option for measuring battery run-down voltage along with current

E5515C wireless communications test set

Key capabilities:

- Supports most wireless formats
- Firmware upgrades add new/emerging formats and enhancements
- Place DUT into any desired operating condition to measure battery drain

14565B device characterization software with test automation

Key capabilities:

- Capture long-term, continuous battery drain measurements with no programming
- Data logging mode records up to 1,000 hours of information.
- Time-stamped data log markers correlate current drain to DUT stimulus

N5970A UMTS and N5971A interactive functional test software

Key capabilities:

- Functionally tests 3G and 4G devices for realistic user experiences
- Tests SMS, MMS, FTP data services, including simultaneous activities
- Automatically generates test script code from GUI
- Automatically generates battery drain log markers for DUT stimuli

To learn more

Visit our application-specific web site:

Battery Power Management for Portable Electronic Devices Web page
www.keysight.com/find/currentdrain

Check out these related application notes:

Battery Drain Analysis Improves Mobile Device Operating Time

Wireless Mobile Device Design Validation: Accelerate Your Testing with Automated Test Solutions

Take a closer look at information on these related products:

14565B software

66300 Series mobile communications DC sources

E5515C wireless communications test set

N5970A/71A UMTS/CDMA interactive functional stress test software

Case Study 3: Handset reference design house uncovers CPU capacity issue

Problem

Occasionally, a resident data security application used 100% of a new handset's CPU capacity. When the handset received an email message in this state, resource demand exceeded capacity and the CPU would lock up briefly. Because of its dependence on a certain sequence of events, the customer's standard validation tests did not catch the issue. Tests showed only slightly shorter battery life, which the test team did not investigate further.

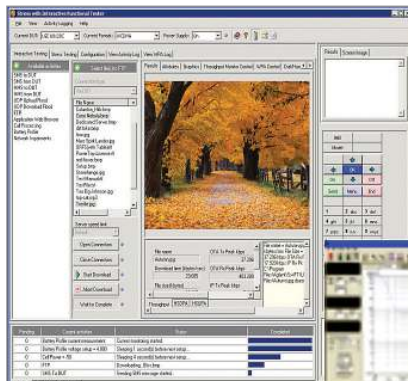

Solving the problem

The reference design house test team easily reproduced the combination of operating conditions with Keysight test equipment and software. The team quickly set up the 14565B software to log current drain while the N5970A interactive function stress test software provided a combination of data calls and channel quality changes over an extended period.

Results

The current drain logging showed peculiar current handling issues after several repeated attempts. Time-stamped data markers allowed the test team to correlate the current drain anomaly to the particular combination of events that led to the problem. The new handset was sent back to the development team, which used protocol analysis to isolate an issue with the application.

“How can I be sure this solution will work for me?”

- The 14565B's high-speed, continuous current drain sampling reflects the measurement methodology described by GSMA's battery life testing requirements and other similar test standards.
- Keysight continually develops firmware and software upgrades to bring you new enhancements and capabilities to keep your solution up to the latest standards, thus assuring your investment for years to come.
- Our battery drain application experts are always available for you, both before and after your purchase.

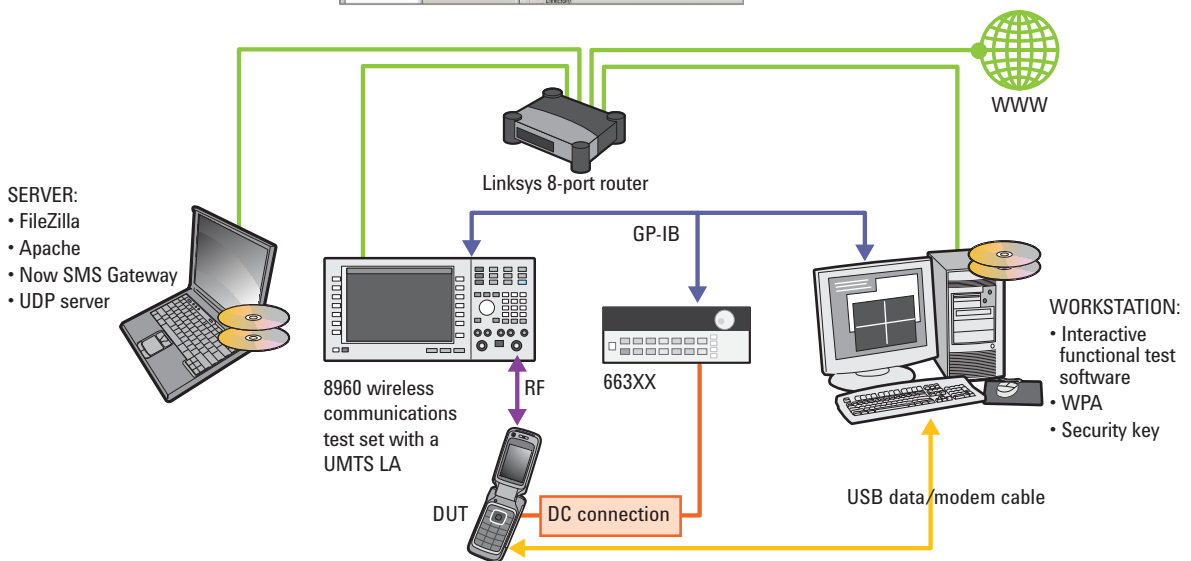
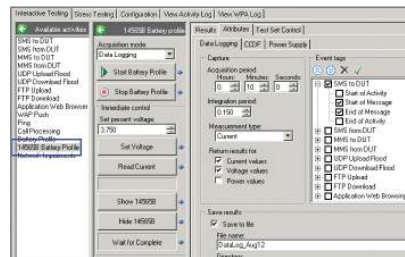

Talk to an expert

Get answers to your questions about test uncertainties. Call 1 800 829-4444.

Get a quote: www.keysight.com/find/qq

myKeysight

myKeysight

www.keysight.com/find/mykeysight

A personalized view into the information most relevant to you.

Three-Year Warranty

www.keysight.com/find/ThreeYearWarranty

Keysight's commitment to superior product quality and lower total cost of ownership. The only test and measurement company with three-year warranty standard on all instruments, worldwide.



Keysight Assurance Plans

www.keysight.com/find/AssurancePlans

Up to five years of protection and no budgetary surprises to ensure your instruments are operating to specification so you can rely on accurate measurements.



For more information on Keysight Technologies' products, applications or services, please contact your local Keysight office. The complete list is available at: www.keysight.com/find/contactus

Americas

Canada	(877) 894 4414
Brazil	55 11 3351 7010
Mexico	001 800 254 2440
United States	(800) 829 4444

Asia Pacific

Australia	1 800 629 485
China	800 810 0189
Hong Kong	800 938 693
India	1 800 112 929
Japan	0120 (421) 345
Korea	080 769 0800
Malaysia	1 800 888 848
Singapore	1 800 375 8100
Taiwan	0800 047 866
Other AP Countries	(65) 6375 8100

Europe & Middle East

Austria	0800 001122
Belgium	0800 58580
Finland	0800 523252
France	0805 980333
Germany	0800 6270999
Ireland	1800 832700
Israel	1 809 343051
Italy	800 599100
Luxembourg	+32 800 58580
Netherlands	0800 0233200
Russia	8800 5009286
Spain	0800 000154
Sweden	0200 882255
Switzerland	0800 805353
	Opt. 1 (DE)
	Opt. 2 (FR)
	Opt. 3 (IT)
United Kingdom	0800 0260637

For other unlisted countries:
www.keysight.com/find/contactus
 (BP-07-10-14)