

**Instruction Manual
Model 177 Microvolt DMM
and
Model 1788 Battery Pack**

**©1978, Keithley Instruments, Inc.
Cleveland, Ohio, U.S.A.
Document Number 29683**

Specifications

DC VOLTAGE

RANGE	MAXIMUM READING	ACCURACY (12 mo.) 18°–28°C ± (% rdg + digits)	MAXIMUM ALLOWABLE INPUT
20mV*	19.999	0.04% + 2d	1200V momentary
200V*	199.99	0.04% + 1d	1200V momentary
2V	1.9999	0.03% + 1d	1200V momentary
20V	19.999	0.03% + 1d	1200V
200V	199.99	0.03% + 1d	1200V
1200V	1200.0	0.035% + 1d	1200V

*Front panel zero

TEMPERATURE COEFFICIENT (0°–18°C and 28°–55°C):

± (0.005% + 0.1 digit)/°C except ± (0.005% + 0.6 digit)/°C on the 20mV range

INPUT RESISTANCE: 10MΩ ± 0.5%

NMRR: Greater than 80dB on the 20mV range at 50Hz and 60Hz; greater than 60dB on all other range

CMRR (1kΩ unbalance): Greater than 120dB at DC, 50Hz & 60Hz

AC VOLTAGE

RANGE	MAXIMUM READING	ACCURACY (12 mo.) (above 2000 counts) 18°–28°C; 100Hz–10kHz ± (% rdg + digits)
200mV	199.99	0.5% + 15d
2V	1.9999	0.5% + 15d
20V	19.999	0.5% + 15d
200V	199.99	0.5% + 15d
1000V	1000.0	0.5% + 15d

EXTENDED FREQUENCY ACCURACY (45Hz–20kHz): ± (0.7% + 15 digits)

TEMPERATURE COEFFICIENT (0°–18°C & 28°–55°C; 45Hz–20kHz): ± (0.05% + 2 digits)/°C

RESPONSE: True root mean square

CREST FACTOR: 3

INPUT IMPEDANCE: 1MΩ ± 1% shunted by less than 75pF.

MAXIMUM ALLOWABLE INPUT VOLTAGE: 1000V rms, 1400V peak, 10⁷Hz maximum

CMRR (1kΩ unbalance): 60dB at DC, 50Hz and 60Hz

RESISTANCE

RANGE	MAXIMUM READING	ACCURACY (12 mo.) 18°–28°C ± (% rdg + digits)	TEMPERATURE COEFFICIENT 0°–18°C & 28°–55°C ± (% rdg + digits)/°C	NOMINAL APPLIED CURRENT
20Ω*	19.999	0.5% + 3d	0.004% + 0.6d	1mA
200Ω*	199.99	0.5% + 2d	0.004% + 0.2d	1mA
2kΩ	1.9999	0.04% + 1d	0.004% + 0.2d	1mA
20kΩ	19.999	0.04% + 1d	0.004% + 0.2d	100μA
200kΩ	199.99	0.04% + 1d	0.004% + 0.2d	10μA
2000kΩ	1999.9	0.04% + 1d	0.005% + 0.2d	1μA
20MΩ	19.999	0.10% + 1d	0.02% + 0.2d	0.1μA

*Front panel zero

MAXIMUM ALLOWABLE INPUT: 350V peak

OPEN-CIRCUIT VOLTAGE: 5 volts

DC & TRMS AC CURRENT

RANGE	MAXIMUM READING	ACCURACY (12 mo.) 18°–28°C ± (% rdg + digits)			MAXIMUM VOLTAGE BURDEN
		DC*	AC 45Hz–10kHz (above 2000 counts)		
20μA	19.999	0.2% + 2d	—	0.02V	
200μA	199.99	0.2% + 1d	0.8% + 15d	0.2V	
2mA	1.9999	0.2% + 1d	0.8% + 15d	0.2V	
20mA	19.999	0.2% + 1d	0.8% + 15d	0.2V	
200mA	199.99	0.2% + 1d	0.8% + 15d	0.25V	
2000mA	1999.9	0.2% + 1d	0.8% + 15d	0.6V	

*Front panel zero

MAXIMUM INPUT: 2A, 250V DC or rms (fuse protected)

TEMPERATURE COEFFICIENT (0°–18°C and 28°–55°C):

DC: ± (0.2 digits)/°C except ± (0.01% + 0.6 digits)/°C on 20μA range.

AC: ± (0.07% + 2 digits)/°C

CREST FACTOR: 3

GENERAL

DISPLAY: Five 0.5" LED digits, appropriate decimal point and polarity indication

CONVERSION PERIOD: 400mS

OVERRANGE INDICATION: Display blinks all zeros above 19999 counts

MAXIMUM COMMON MODE VOLTAGE: 1400V peak

ANALOG OUTPUT: Output Voltage: 1V = 10,000 counts

Output Resistance: 5000Ω

ENVIRONMENT: Operating: 0°C to 55°C; 0% to 80% relative humidity up to 40°C.

Storage: –25°C to +65°C

CONNECTORS: Input: Binding posts

Output: Banana jacks

POWER: 105–125 or 210–250 volts (switch selected), 90–110V available, 50–60Hz, 8 watts. Optional 6 hour battery pack, Model 1788

DIMENSIONS WEIGHT: 85mm high × 235mm wide × 275mm deep (3½" × 9¼" × 10¾"). Net weight: 1.7kg (4 lb)

ACCESSORIES AVAILABLE:

Model 1010:	Single Rack Mounting Kit
Model 1017:	Dual Rack Mounting Kit
Model 1301:	Temperature Probe
Model 1600A:	High Voltage Probe (40kV)
Model 1641:	Kelvin Test Leads
Model 1651:	50-Ampere Current Shunt
Model 1681:	Clip-On Test Lead Set
Model 1682A:	RF Probe
Model 1683:	Universal Test Lead Kit
Model 1684:	Hard Shell Carrying Case
Model 1685:	Clamp-On AC Probe
Model 1691:	General Purpose Test Lead Set
Model 1779:	Spare Parts Kit
Model 1788:	Rechargeable Battery Pack
Model 1792:	Isolated BCD Output
Model 1793:	Isolated IEEE-488 Output

TABLE OF CONTENTS

Paragraph	Title	Page
SECTION 1—GENERAL INFORMATION		
1.1	Introduction	1-1
1.2	Model 177 Features	1-1
1.3	Warranty Information	1-1
1.4	Manual Addenda	1-1
1.5	Safety Symbols and Terms	1-1
1.6	Safety Precautions	1-1
1.7	Specifications	1-1
1.8	Unpacking and Inspection	1-2
1.9	Scope of Model 177 Instruction Manual	1-2
1.10	Optional Accessories	1-2
1.10.1	Power Options	1-2
1.10.2	Cables and Connectors	1-2
1.10.3	Probes and Shunts	1-2
1.10.4	Carrying Case and Rack Mount	1-2
1.10.5	Output Options	1-2
SECTION 2—OPERATION		
2.1	Introduction	2-1
2.2	Safety Precautions for High Energy Circuits	2-1
2.3	Preparation for Use	2-1
2.4	Operation on Line Power	2-1
2.5	Operation on Battery Pack Power	2-1
2.6	Battery Charging	2-1
2.7	Operating Instructions	2-3
2.8	Zero Adjustment	2-3
2.9	DC Voltage Measurement	2-3
2.10	AC Voltage Measurement	2-5
2.11	Resistance (Ω) Measurement	2-6
2.12	DC Current Measurement	2-7
2.13	AC Current Measurement	2-7
2.14	TRMS Measurements (AC + DC)	2-8
2.15	Analog Output	2-8
2.16	Tilt Bail Adjustment	2-8
SECTION 3—PERFORMANCE VERIFICATION		
3.1	Introduction	3-1
3.2	Recommended Test Equipment	3-1
3.3	Environmental Conditions	3-1
3.4	Performance Verification Procedure	3-1
3.4.1	Initial Conditions	3-1
3.4.2	DC Voltage Accuracy Check (2V to 1200V Ranges)	3-1
3.4.3	DC Voltage Accuracy Check (20mV and 200mV Ranges)	3-2
3.4.4	AC Voltage Accuracy Check	3-2
3.4.5	Resistance (Ω) Accuracy Check	3-2
3.4.6	DC Current Accuracy Check	3-3
3.4.7	Analysis	3-3
SECTION 4—THEORY OF OPERATION		
4.1	Introduction	4-1
4.2	Overall Operation	4-1
4.2.1	Signal Conditioning	4-1

4.2.2	A/D Converter	4-2
4.2.3	Range Switching	4-2
4.3	AC Converter	4-2
4.3.1	Scaling	4-2
4.3.2	AC Conversion	4-2
4.3.3	AC Current Measurements	4-2
4.4	DC Signal Conditioning	4-2
4.4.1	Input Attenuation	4-3
4.4.2	Chopper	4-3
4.5	Ohms Conversion	4-4
4.5.1	Floating Current Source	4-4
4.5.2	Chopper	4-4
4.5.3	Adjustments and Input Overload Protection	4-4
4.6	Analog Output	4-4
4.7	Clock	4-4
4.8	A/D Converter	4-4
4.8.1	Auto-Zero	4-5
4.8.2	Signal-Interface	4-5
4.8.3	Reference-Integrate	4-5
4.9	Display	4-6
4.10	AC Power Supply	4-6
4.11	Model 1788 Battery Pack	4-6
4.11.1	Battery Charging Circuit	4-6
4.11.2	Battery Operation and Shutdown Circuit	4-6
 SECTION 5—MAINTENANCE		
5.1	Introduction	5-1
5.2	Recommended Test Equipment	5-1
5.3	Environmental Conditions	5-1
5.4	Calibration Procedure	5-1
5.4.1	Calibration Shield Installation	5-1
5.4.2	Warm-Up	5-1
5.4.3	Calibration Instructions	5-1
5.5	Troubleshooting	5-2
5.6	Troubleshooting Procedure	5-2
5.6.1	Calibration Shield/Battery Pack Removal	5-2
5.6.2	Line Power	5-4
5.6.3	Battery Power	5-4
5.6.4	Display and A/D Converter	5-4
5.6.5	AC Converter	5-4
5.6.6	Chopper Amplifier and Ohms Source	5-4
5.6.7	Current Shunts	5-4
5.7	Front Panel ZERO Knob Removal and Replacement	5-4
5.8	Fuse Replacement	5-5
5.9	Model 1788 Battery Pack Installation	5-6
 SECTION 6—REPLACEABLE PARTS		
6.1	Introduction	6-1
6.2	Parts List	6-1
6.3	Ordering Information	6-1
6.4	Factory Service	6-1
6.5	Component Location Drawings	6-1
6.6	Schematic Diagrams	6-1
6.7	Maintenance Kit	6-1

LIST OF FIGURES

Figure	Title	Page
1-1	Model 177 Front Panel	1-0
2-1	Model 177 Rear View of Standard Line Voltage Instrument	2-2
2-2	Model 177 Rear View of Optional Line Voltage Instrument	2-2
2-3	Operating Controls	2-5
3-1	Test Circuit for 20mVDC Accuracy Check	3-2
4-1	Model 177 Simplified Signal Flow Block Diagram	4-1
4-2	Simplified Signal Conditioning	4-3
4-3	A/D Converter Function	4-5
5-1	Test Point Locations	5-3
5-2	Integrator and Comparator Waveforms	5-4
5-3	Front Panel Zero Knob Removal	5-5
5-4	Battery Pack Installation	5-5
6-1	Model 177 Covers and Panels	6-2
6-2	Model 177 PC-476, Component Location Drawing, Dwg. No. 29474D	6-11
6-3	Display Board PC-475, Component Location Drawing, Dwg. No. 29652C	6-15
6-4	Model 1788 Battery Pack PC-451, Component Location Drawing, Dwg. No. 29007C	6-16
6-5	Model 1788 Battery Pack, Schematic Diagram, Dwg. No. 29659C	6-17
6-6	Model 177 4 ½ Digit Multimeter, Schematic Diagram, Dwg. No. 29658E	6-19

LIST OF TABLES

Table	Title	Page
2-1	Model 177 DMM Condensed Operating Instructions	2-4
2-2	Resistance Ranges	2-6
3-1	Recommended Test Equipment for Performance Verification	3-1
3-2	DC Voltage Performance Check (2V to 1200V Ranges)	3-2
3-3	AC Voltage Accuracy Check	3-2
3-4	Resistance Accuracy Check	3-3
3-5	DC Current Accuracy Check	3-3
4-1	Range Switch Correlation	4-2
4-2	AC Converter Attenuation Amplification	4-3
4-3	DC Signal Conditioning Attenuation and Gain	4-3
4-4	Ohms Conversion	4-4
5-1	Recommended Test Equipment for Calibration	5-1
5-2	Calibration Procedure	5-2
5-3	Line Power Checks	5-6
5-4	Battery Power Checks	5-7
5-5	Display	5-8
5-6	A/D Converter	5-8
5-7	AC Converter	5-9
5-8	DC Attenuator and Chopper Amplifier	5-10
5-9	Ohms Source and Resistors	5-11
5-10	Current Shunts	5-11
5-11	Adjustment of Battery Charge Voltage	5-12
6-1	Model 177 Spare Parts Kit	6-3
6-2	Mother Board, Parts List	6-4
6-3	Model 1788 Battery Pack, Parts List	6-8
6-4	Display Board, Parts List	6-9

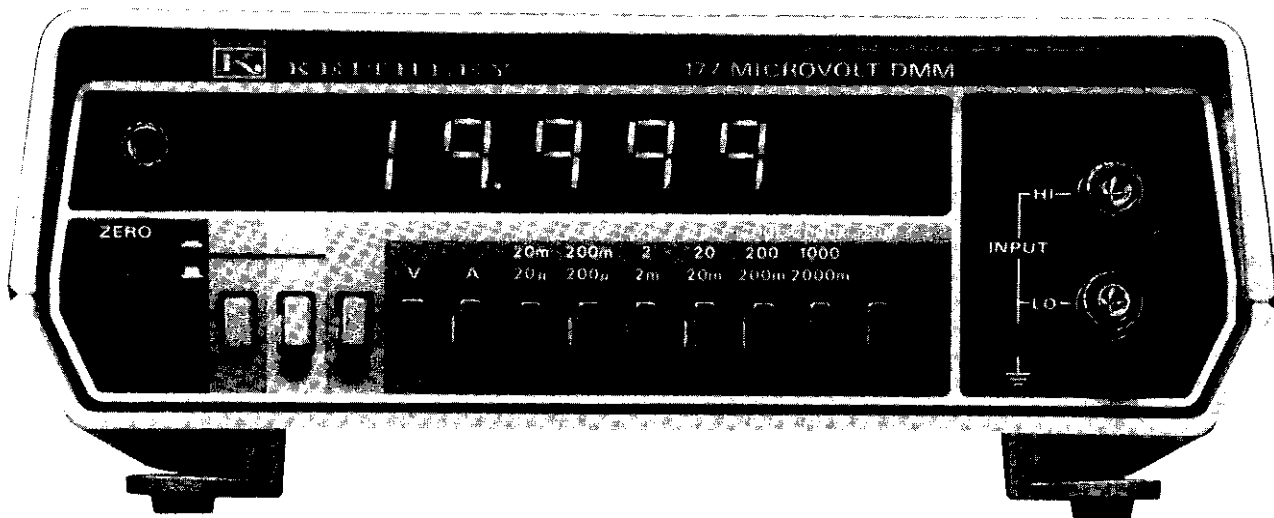

Figure 1-1. Model 177 Front Panel

SECTION 1 GENERAL INFORMATION

1.1 INTRODUCTION

The Keithley Model 177 Microvolt DMM is a versatile, highly sensitive digital multimeter which is used for measurement of DC and AC voltages, DC and AC currents, as well as resistance. For a complete summary of ranges for each of these five functions, refer to the specifications at the front of this manual. Ranges and functions are easily selected with front panel pushbuttons, while connections for all functions are easily made with a single set of front panel input terminals.

1.2 MODEL 177 FEATURES

1. 4½ Digit LED Display—An easy to read 4½ digit display shows 20,000 counts of information with automatic polarity indication.
2. 1μV/1mΩ Resolution—The Model 177 is capable of reading DC voltages as low as 1μV and resistances down to 1mΩ.
3. Front Panel Zero—The front panel zero control may be used to compensate for thermal offsets or lead resistance when making measurements.
4. Analog Output—An analog output of 1V/10,000 counts is available on the rear panel.

1.3 WARRANTY INFORMATION

Warranty information may be found inside the front cover of this manual. Should it become necessary to use the warranty, contact your nearest Keithley representative or the factory to determine the correct course of action. Keithley Instruments maintains service facilities in the United States, West Germany, Great Britain, France, the Netherlands, Switzerland and Austria. Information concerning the application, operation or service of your instrument may be directed to the applications engineer at any of these locations. Check inside the front cover of this manual for addresses.

1.4 MANUAL ADDENDA

Information concerning improvements or changes to the instrument that occur after the printing of this manual will be covered in an addendum sheet packed with the instrument. Be sure to review these changes before attempting to operate or service the instrument.

1.5 SAFETY SYMBOLS AND TERMS

The following safety symbols and terms are used in this manual or may be found on the Model 177.

The symbol  on the instrument indicates that the user should refer to the operating instructions.

The symbol  on the instrument denotes that a potential of 1000V or more may be found present on the terminals. Standard safety practice should be observed when such dangerous voltages are encountered.

The **WARNING** heading used in this manual explains dangers that could result in personal injury or death if not handled properly. Be sure to read the **WARNING** information carefully before performing the associated procedure.

The **CAUTION** heading is used in this manual explains hazards that could damage the instrument.

1.6 SAFETY PRECAUTIONS

The following safety precautions should be observed before operating any digital multimeter.

1. This instrument is intended for use by qualified personnel who recognize shock hazards and are familiar with the safety precautions required to avoid possible injury. Read over the manual carefully before operating this instrument.
2. Exercise extreme caution when a shock hazard is present at the instrument's input. The American National Standards Institute (ANSI) states that a shock hazard exists when voltage levels greater than 30V rms or 42.4V peak are present. A good safety practice is to expect that hazardous voltage is present in any unknown circuit before measuring.
3. Inspect the test leads for possible wear, cracks or breaks before each use. If any defects are found, replace with test leads that have the same measure of safety as those supplied with the instrument.
4. For optimum safety do not touch the test leads of the instrument while power is applied to the circuit under test. Turn the power off and discharge all capacitors, before connecting or disconnecting the instrument.
5. Do not touch any object which could provide a current path to the common side of the circuit under test or power line (earth) ground. Always make measurements with dry hands while standing on a dry, insulated surface, which is capable of withstanding the voltage being measured.
6. Exercise extreme precaution when testing high energy power circuits (AC line or mains, etc.). Refer to the operation section of the manual.
7. Do not exceed the instrument's maximum allowable input as defined in the specifications and operation section.

1.7 SPECIFICATIONS

Detailed Model 177 specifications are located at the front of this manual.

1.8 UNPACKING AND INSPECTION

The Model 177 was carefully inspected, both mechanically and electrically, before shipment. Upon receiving the instrument, carefully unpack it from the shipping carton and check for any obvious signs of physical damage that might have occurred during shipment. Report any damage to the shipping agent at once. Retain the original packing materials in case reshipment becomes necessary. The following items are included with every Model 177 shipment.

1. Model 177 Micro-Volt DMM
2. Model 177 Instruction Manual
3. Additional accessories as ordered.

1.9 SCOPE OF THE MODEL 177 INSTRUCTION MANUAL

This manual contains information necessary to operate and service both the Model 177 and the optional Model 1788 Battery Pack and is divided into the following sections.

1. Section 2 contains operating information.
2. Information necessary to verify that instrument performance is within specified accuracy is located in Section 3.
3. Theory of operation is covered in Section 4.
4. Servicing information, including Model 1788 installation instructions, may be found in Section 5.
5. Replaceable parts information, component layouts and schematic diagrams are located in Section 6.

1.10 OPTIONAL ACCESSORIES

1.10.1 Power Options

The Model 177 can be powered by line voltage (105-125V at 50-60Hz or 210-250V at 50-60Hz—standard ranges) or the optional Model 1788 Rechargeable Battery Pack. (Optional line voltage ranges are described in Section 2.) The Model 1788 is available factory-installed or is field-installable. Installation and operating instructions are given in Section 2.

1.10.2 Cables and Connectors

Model 1681 Clip-On Test Lead Set—This set contains two 1.2m (48 in.) leads with banana plugs at one end and spring-action clip-on probes at the other end.

Model 1683 Universal Test Lead Kit—This kit contains two 1m (40 in.) test leads and 14 screw-in adapter tips. The tips consist of two alligator tips with boots, four banana plugs, phone tips, two spade lugs and four heavy duty tip plugs which permit connection of the Model 177 to virtually any source within its measurement range.

1.10.3 Probes and Shunts

Model 1600A High Voltage Probe—The Model 1600A High Voltage Probe extends the measurable DC voltage range up to 40kV. It has a 1000:1 division ratio, so that a reading of 1V on the DMM corresponds to 1kV (1000V). The Model 1600A has a basic accuracy of $\pm 25\%$ and an input resistance of 1000M Ω .

Model 1651 50-Ampere Shunt—The Model 1651 50-Ampere Shunt permits current measurements of up to 50A AC or DC. The shunt has a resistance of $0.001\Omega \pm 1\%$, so that a 50A current will correspond to a reading of 50mV (0.0500V).

Model 1682A RF Probe—The Model 1682A RF Probe permits measurement of AC voltages at frequencies of 20kHz to 250MHz. AC to DC transfer accuracy is 1dB at 1V, and the input voltage range is 0.25V to 15V rms.

Model 1685 Clamp-On AC Current Probe—The Model 1685 Clamp-On Current Probe permits measurement of AC current by clamping around a single conductor, eliminating the need to interrupt the current path. The Model 1685 has a current conversion ratio of 0.1V/A with three ranges (2A, 20A, 200A). Accuracy is $\pm 4\%$ at 60Hz ($\pm 6\%$ at 50Hz).

1.10.4 Carrying Case and Rack Mounts

Model 1684 Carrying Case—The Model 1684 Carrying Case is a hard vinyl case with a fitted foam insert to help protect the Model 177 from damage. There is also room in the case for the instruction manual and small accessories.

Models 1010 and 1017 Rack Mounting Kits—The rack mounting kits permit mounting one (1010) or two (1017) Model 177 DMMs in a 19 inch rack for convenient viewing.

1.10.5 Output Options

Model 1792 Isolated BCD Output—The Model 1792 converts displayed reading to an electrically isolated, latched and buffered parallel BCD format. Output data includes sign, overrange and busy. It is compatible with Model 177 serial number 14,500 and above, and can be either factory or field installed. Installation of the 1792 precludes installation of Models 1788 or 1793.

Model 1793 IEEE-488 Output—The Model 1793 converts displayed readings to IEEE-488 bus compatible outputs to permit automatic gathering of measurement data. Output includes $4\frac{1}{2}$ digit ASCII data, sign an overrange. It operates in either talk-only or addressable modes. The Model 1793 is compatible with Model 177s serial number 16,500 and above, and can be either factory or field installed. Installation of the 1793 precludes installation of the Model 1788 or 1792.

SECTION 2 OPERATION

2.1 INTRODUCTION

This section provides information needed for preparation for use and operation of the Model 177 and Model 1788.

2.2 SAFETY PRECAUTIONS FOR HIGH ENERGY CIRCUITS

To optimize safety when measuring voltage in high energy distribution circuits, read and observe the directions in the following warning.

WARNING

Dangerous arcs of an explosive nature in a high energy circuit can cause severe personal injury or death. If the meter is connected to a high energy circuit when set to a current range, low resistance range or any other low impedance range, the circuit is virtually shorted. Dangerous arcing can result even when the meter is set to a voltage range if the minimum safety spacing is reduced.

When making measurements in high energy circuits use test leads that meet the following requirements:

1. Test leads should be fully insulated.
2. Only use test leads that can be connected to the circuit (e.g. alligator or spade lugs) for a hands-off measurement.
3. Use test leads that do not reduce the arc protection by decreasing the voltage spacing between conductors or terminals.

Use the following sequence when testing power circuits:

1. De-energize the circuit using the regular installed connect-disconnect device such as the circuit breaker, main switch, etc.
2. Attach the test leads to the circuit under test. Use appropriate safety rated leads for this application.
3. Set the DMM to the proper function and range.
4. Energize the circuit using the installed connect-disconnect device and make measurements without disconnecting the DMM.
5. De-energize the circuit using the installed connect-disconnect device.
6. Disconnect the test leads from the circuit under test.

2.3 PREPARATION FOR USE

The Model 177 is shipped ready-to-use on line power. The instrument may also be powered from rechargeable batteries

(when the optional Model 1788 Rechargeable Battery Set is installed.)

2.4 OPERATION ON LINE POWER

The Model 177 DMM has a three-wire line cord which mates with third-wire grounded receptacles. Connect the instrument to AC line power as follows:

CAUTION

Connect only to the line voltage selected. Application of incorrect voltage can damage the instrument.

1. Set the LINE VOLTAGE switch on the back of the instrument to correspond to the line voltage available. Standard ranges are 105V to 125V and 210V to 250V AC as shown in Figure 2-1. Optional ranges of 90V to 110V and 180V to 220V AC are also available as shown in Figure 2-2. As indicated on their respective rear panels, the standard line voltage range instruments use an internal line fuse (F102) of 1/8A rating and the optional line voltage range instruments use a 3/16A fuse. See Section 5.

WARNING

Ground the instrument through a properly earth-grounded receptacle before operation. Failure to ground the instrument can result in severe injury or death in the event of short circuit or malfunction.

2. Plug the power cord into a properly grounded outlet. Operate the Model 177 DMM as described in paragraph 2.7.

2.5 OPERATION ON BATTERY PACK POWER

The Model 177 DMM may also be operated from rechargeable sealed lead-acid batteries contained in the optional Model 1788 Battery Pack. The battery pack will operate the Model 177 DMM for up to six hours. Circuits within the battery pack will automatically shut down the instrument when the battery charge is insufficient to maintain accurate readings. To install the Model 1788, refer to Section 5.

2.6 BATTERY CHARGING

The Model 1788 Battery Pack contains an integral battery charger. To charge the battery pack, install the battery pack in the Model 177 DMM as described above and proceed as follows:

1. Connect the instrument to line power as described in paragraph 2.4.

These adjustments are used only for calibration.
They are not intended for adjustment during operation.

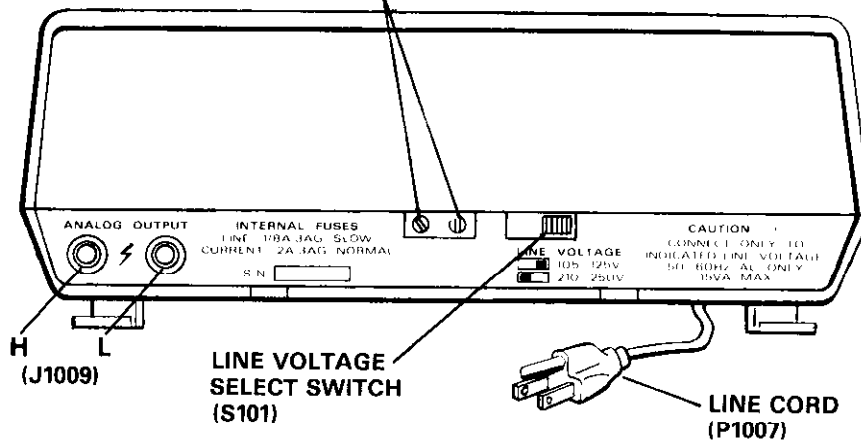

Figure 2-1. Rear View Of Standard Line Voltage Instrument

These adjustments are used only for calibration.
They are not intended for adjustment during operation.

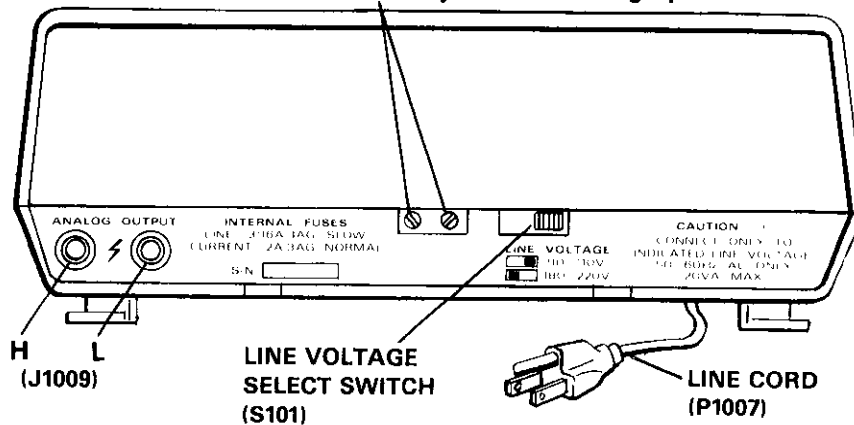

Figure 2-2. Rear View Of Optional Line Voltage Instrument

2. With the power switch off, the battery charge circuitry is automatically energized to charge the battery at the maximum rate. When the battery pack is first installed, or if it has completely discharged, allow it to charge for at least 14 hours in this condition.

NOTE

For maximum battery life, do not allow the battery pack to remain completely discharged. Constant charging will not harm either the battery pack or the instrument. The Model 177 may be operated up to six hours from fully charged batteries. However, since 10 charge/discharge cycles may be required to reach full battery capacity, less than six hours DMM operation can be expected when the battery pack is first installed.

3. When the Model 177 DMM is in use on line power, the battery charger maintains a trickle charge on the battery pack.

2.7 OPERATING INSTRUCTIONS

The basic operating instructions for the Model 177 DMM are outlined in the following steps, and condensed operating instructions are provided on the bottom cover of the instrument and contained in Table 2-1. These instructions should only be used after becoming completely familiar with the operation of the Model 177 through day-to-day use. Until this familiarity has been achieved, best performance and safest operation will be obtained by using the individual instructions provided in this section. Refer to Figure 2-3 and operate the DMM as follows:

1. Turn on the power by depressing the ON/OFF pushbutton and allow a 10 minute warm-up time. Allow additional warm-up for zero stability on lowest DMM and Ω ranges.
2. Select the function with the AC/DC, Ω , V, or A pushbuttons.
3. Select the range by depressing the appropriate pushbutton.
4. Connect the source to the INPUT terminals. Accessories described in Section 1 should be used as required.

CAUTION

Do not exceed the maximum input ratings shown below.

DCV	(20mV, 20mV, 2V): 450V rms continuous; 1200V peak momentary, for up to eight seconds per minute maximum. (20-1200V): 1200V peak.
ACV	(All Ranges): 1000V rms; 1400V peak; 10 ⁷ V•Hz.
DCA, ACA	(All Ranges): 2A, 250V DC or rms (fuse protected).
Ω	(All Ranges): 350V peak.

2.8 ZERO ADJUSTMENT

The front panel zero adjustment provides compensation for test lead resistance and thermal EMFs generated in the circuits connected to the DMM input terminals. The zero adjustment is operative on the 20mV and 200mV ranges of DCV, 20 and 200 Ω ranges and all DCA ranges. In general, the zero must be readjusted whenever the function is changed and the measurement is to be made on a range where the zero adjustment is operative. The accuracy specifications assume that zero is adjusted on the lowest range of the function. Where applicable, a specific zero adjustment instruction is provided in the description of how to make the particular function measurement.

2.9 DC VOLTAGE MEASUREMENT

The Model 177 measures DC voltages from 1 μ V/digit to 1200V. The maximum displayed reading is 19999. Overrange is indicated by a flashing 0000 except on the 1200V range. On the 1200V range, the display can read beyond the maximum allowable input voltage. Use the Model 177 to measure DC volts as follows:

CAUTION

Do not exceed the maximum input voltage ratings, or instrument damage may occur.

1. Turn on power with ON/OFF pushbutton and select DC with the AC/DC pushbutton.
2. Select the desired range from the six ranges available. The decimal point is positioned by the range pushbuttons. The 1200V DC range is selected by the 1000 pushbutton.

NOTE

The 20M pushbutton is inoperative for DC volts. If this pushbutton is inadvertently depressed, the Model 177 will read zero regardless of the voltage applied and the eight second per minute overload rating will apply.

3. Connect the signal to be measured between the INPUT HI and LO binding posts. The binding posts accept wires, spade lugs or banana plugs for ease of connecting the circuit to be measured. Low thermal cabling and connections are recommended for measurements on the 20mV and 200mV ranges.
4. For the top four ranges, merely observe the displayed digits, polarity sign and decimal point locations. The top four ranges are direct-reading in volts. Nominal settling time is located to within one digit of final reading.
5. For the 20mV and 200mV ranges, the front panel ZERO must be adjusted to obtain rated accuracy. This adjustment is necessary to compensate for thermal EMFs generated by the connections to the circuit to be measured. These voltages may be only a few microvolts or several tens of microvolts. The zero adjustment span is set up at the factory to allow at least $\pm 75\mu$ V adjustment. To adjust zero, proceed as follows:

Table 2-1. Model 177 DMM Condensed Operating Instructions

Summary of Function, Ranges and Other Information					
Function	Range (Note 2)	Accuracy 18°C - 28°C (Note 1)	Input Impedance	Max. Input (Note 1)	Front Panel Zero
DCV (—)	20mV	0.04% Rdg + 2D	10MΩ	1200V Momentary	Yes
	200mV	0.04% Rdg + 1D			
	2V	0.03% Rdg + 1D		1200V	No
	20V				
	200V				
1200V	0.035% Rdg + 1D				
ACV (≈) (Note 3)	200mV	0.5% Rdg + 15D 100Hz-10kHz	1MΩ 75pF	1000V RMS 10 ⁷ V•Hz	No
	2V				
	20V				
	200V	0.7% Rdg + 15D 45Hz-20kHz			
	1000V				
DCA	20μA	0.2% Rdg + 2D	0.02V Burden	2A, 250V DC or rms (Note 4)	Yes
	200μA	0.2% Rdg + 1D	0.2V Burden		
	2mA				
	20mA				
	200mA		0.25V Burden		
	2000mA		0.6V Burden		
ACA (Note 3)	200μA		0.8% Rdg + 15D 45Hz-10kHz	0.2V Burden	2A, 250V DC or rms (Note 4)
	2mA	0.25V Burden			
	20mA				
	200mA				
	2000mA			0.6V Burden	
Ω (Ohms)	20	0.05% Rdg + 3D	20mV F.S	350V Peak	Yes
	200	0.05% Rdg + 2D	200mV F.S.		
	2k	0.04% Rdg + 1D	2V at Full Scale 5V Max Open Circuit		No
	20k				
	200k				
	2000k				
20M	0.1% Rdg + 1D				

ANALOG OUTPUT: ±2V full scale, 5kΩ output resistance

Note 1: See manual for detailed information.

Note 2: Overrange is indicated by flashing 0000.

Note 3: True root mean square, crest factor = 3.

Note 4: Current fuse (installed internally) is 2A, 3AG normal blow. See Figure 5-4 for location.

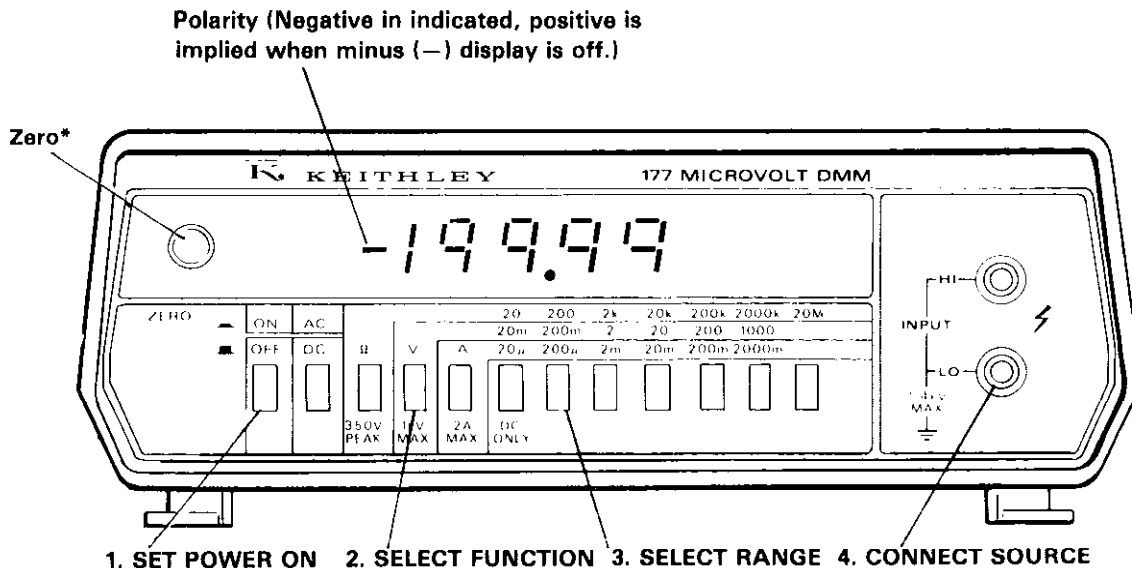

Figure 2-3. Operating Controls

NOTE

Due to the long thermal time constant of the 20mV range zero, a one hour warm-up time may be necessary to adjust zero to the final 1 μ V setting. Typically, only a one to three microvolt zero shift can be expected during this warm-up period, if the ambient temperature is within the specified 18° to 28°C and the instrument has not been subjected to temperature outside of this range. Thus, since the expected zero shift is both small and slow, normally zero can be adjusted and several measurements taken without having to achieve the final zero setting.

- A. Make connections to the Model 177 as described above. For the best performance, connections should be made to the binding posts rather than using banana plugs.
- B. Set the Model 177 to the 20mV range.
- C. Disconnect the leads at the circuit to be measured and short them.
- D. Allow the thermal EMFs generated at the connections to stabilize.
- E. Adjust the front panel ZERO knob for a display indication of 0.000mV (a flashing ± 0.001 mV is permissible.)

NOTE

The ZERO control operates only on the 20mV and 200mV ranges. It has no effect on the other DC voltage ranges.

- F. Make the measurements by applying the signal and reading the mV on the display. Nominal settling time

for the 20mV range is three seconds to within one digit of final reading.

NOTE

An overload input to the Model 177 may cause temporary zero shift due to thermal gradients.

- G. The zero setting for the 20mV range will also be valid for the 200mV range. Nominal setting time for the 200mV range is one second to within one digit of final reading.
- 6. The optional Model 1600A High Voltage Probe can be used with the Model 177 to measure DC voltage up to 40kV, at reduced accuracy.

2.10 AC VOLTAGE MEASUREMENT

The Model 177 measures AC voltages from 10 μ V to 1000V. The instrument measures the true root mean square (TRMS) of a signal within the frequency range of 45Hz to 20kHz. The maximum reading is 19999. Overrange is indicated by a flashing 0000 except on the 1000V range. On the 1000V range, the display can read beyond the maximum allowable input voltage. The maximum crest factor for rated accuracy is 3. AC accuracy is specified for 2000 counts and above. Nominal settling time for all AC voltage ranges is 2.5 second to within 10 digits of final reading. Use the Model 177 DMM to measure AC volts as follows:

- 1. Turn on power and set the AC/DC pushbutton to the in or AC position. Depress the V pushbutton.

NOTE

The 20 μ and 20M ranges are inoperative for AC volts. If the 20 μ pushbutton is inadvertently

depressed, the display will read overrange, signalling the user to go to the next higher range. If 20M is depressed, the display will read zero regardless of the voltage applied. The method of calibrating the converter may yield an offset up to 125 digits with the Model 177 input shorted. This does not affect instrument accuracy.

2. Select the desired range from the five ranges available.

CAUTION
MAXIMUM ALLOWABLE INPUT VOLTAGE
(All ranges): 1000V rms, 1400V peak, 10⁷V•Hz maximum. Do not exceed the maximum rating. Instrument damage may occur.

3. Connect signal to be measured between INPUT HI and LO terminals. Observe the displayed digits and decimal point location. The 200mV range is direct-reading in mV and the remaining four ACV ranges are direct-reading in volts.
4. The crest factor (CF) is the ratio of the peak voltage to the rms voltage as follows:

$$CF = \frac{V_{PEAK}}{V_{RMS}}$$

NOTE

There will be some additional measurement error for signals with a crest factor greater than 3 (CF > 3).

Typical crest factors are as follows:

Sine Wave	CF = 1.4
Square Wave	CF = 1
Triangular Wave	CF = 1.7
Positive pulse train (duty cycle CF = 3 is 0.11)	CF = $\sqrt{1/\text{duty cycle}}$

5. The optional Model 1682A RF Probe can be used with the Model 177 to measure 0.25V to 15V rms AC signals with a frequency of 20kHz to 250MHz (and above at reduced accuracy).
6. Refer to paragraph 2.14 for TRMS measurements of a signal with both AC and DC components.

2.11 RESISTANCE (Ω) MEASUREMENT

The Model 177 DMM measures resistance from 1mΩ/digit to 20MΩ. See Table 2-2 for ranges. Nominal settling times to within one digit of final reading are: three seconds on the 20Ω range; two seconds on the 2000kΩ and 20MΩ ranges; one second on the other four Ω ranges. Use the Model 177 to measure resistance as follows:

1. Turn on power and depress the Ω pushbutton.

CAUTION
MAXIMUM ALLOWABLE INPUT VOLTAGE
(All ranges): 350V peak. Do not exceed maximum rating. Instrument damage may occur.

2. Connect the circuit to be measured to the INPUT binding posts and select the desired range from the seven available.

Table 2-2. Resistance Ranges

Range Setting	Maximum Reading	Full Scale Voltage**	Nominal Applied Current
20Ω*	19.999	20mV	1mA
200Ω*	199.99	200mV	1mA
2kΩ	1.9999	2V	1mA
20kΩ	19.999	2V	100μA
200kΩ	199.99	2V	10μA
2000kΩ	1999.9	2V	1μA
20MΩ	19.999	2V	0.1μA
*Front Panel Zero	All Ranges		
	Overrange: Flashing 0000	Open Circuit: 5V max.	Maximum Allowable Input: 350V Peak

**HI binding post (red) is negative.

3. Observe the displayed digits and decimal point to measure resistance using the 2k, 20k, 200k, 2000k and 20MΩ ranges. The full scale voltage drop for these ranges is 2V which is sufficient to cause forward conduction of semiconductor junctions. The HI (Red) terminal is negative. To measure a resistance in parallel with a semiconductor junction without turning on the junction, either reverse bias the junction or select the next higher Ω range. The latter method is possible because of the one decade reduction of applied test current, but will result in a measurement with 3 ½ digit accuracy. It is suggested that the 2kΩ range be used for diode testing. This range has a nominal 1mA test current and the displayed reading is the forward voltage drop in volts.

NOTE

The front panel ZERO control operates only on the 20Ω and 200Ω ranges. It has no effect on the other resistance ranges.

4. Before making measurements on the 20Ω or 200Ω ranges, adjust front panel ZERO on the 20Ω range to compensate for test lead resistance. Best performance will be obtained on the low ohm ranges when test connections are made to the binding posts, rather than using banana plugs. Adjust ZERO and make resistance measurements as follows:

- A. Select 20 Ω range.
- B. Disconnect the test leads at the circuit to be measured and short them. If measurement is to be made right at the INPUT terminals (no test leads used) place a short, such as a piece of copper wire, across the binding posts.
- C. Adjust the front panel ZERO knob for a display indication of 0.000 \pm 0.001 Ω (flashing). The nominal ZERO adjustment span is 200m Ω .

NOTE

The specified accuracy for the 20 Ω and 200 Ω ranges assumes that ZERO was adjusted on the 20 Ω range. Re-adjust zero on the 20 Ω range each time that a different set of leads is used or whenever measurements have been made on either the two lowest DC voltage ranges or any DC current range. The zero setting for those measurements will be different than the zero setting of ohms. Also, re-adjust zero whenever the instrument is used outside the temperature range of 18° to 28°C.

- D. Reconnect the test leads to the circuit to be measured.
- E. Select either 20 Ω range or 200 Ω range. Read the displayed digits and decimal point.

NOTE

An input overload to the Model 177 may cause a temporary zero shift due to thermal gradients.

2.12 DC CURRENT MEASUREMENT

The Model 177 measures DC current from 1nA/digit to 2A, over six ranges (the 20M range is not operative and the instrument will read zero if 20M pushbutton is depressed). The maximum reading is 19999. Overrange is indicated by a flashing 0000. Overload is protected by fuse F101, a 2A 3AG normal-blow fuse. Nominal settling time for DC current ranges is one second to within one digit of final reading except three seconds on 20 μ A range.

1. Before making DC current measurements, the front panel ZERO must be adjusted on the 20 μ A range. This adjustment is necessary to remove any offset that was introduced by adjusting ZERO for a low DC voltage measurement or a low Ω measurement. This adjustment will also be necessary whenever the instrument is used outside of the temperature range of 18° to 28°C. The specified accuracy for the DC current ranges assumes that ZERO was adjusted on the 20 μ A range. Adjust ZERO as follows:
 - A. Disconnect all circuits from the Model 177 INPUT terminals. The INPUT terminals must have an open circuit.
 - B. Turn on power and set the AC/DC pushbutton to the out or DC position.
 - C. Depress A and 20 μ pushbuttons.

- D. Adjust front panel ZERO knob for a display indication of 0.000 μ A \pm .001 flashing.
2. After adjusting ZERO, use the Model 177 to measure DC current as follows:

CAUTIONS

Do not install a larger capacity fuse than the one originally supplied (2A). Current fuse F101 (shown in Figure 5-4) protects the instrument against over-current.

- A. Select the desired range from the six ranges available.
- B. Connect the circuit to be measured to the INPUT terminals.
- C. Read the displayed polarity, digits and decimal point. Select the next higher range if overrange is indicated.

2.13 AC CURRENT MEASUREMENT

The Model 177 measures AC current from 10nA/digit to 2A, over five ranges. (The 20 μ A and 20M ranges are not operative. See note below.) The 200 μ A range is direct-reading in microamperes. The remaining AC current ranges are direct-reading in milliamperes. The maximum reading is 19999. Overrange is indicated by a flashing 0000. Overload is protected by fuse F101, a 2A, 3AG normal-blow fuse. The instrument measures the true root mean square (TRMS) of waveforms in the frequency range of 45 to 10kHz. Use the Model 177 to measure AC current as follows:

1. Turn on power and set the AC/DC pushbuttons to in or AC position. Depress the A pushbutton.

CAUTION

Do not install a larger capacity fuse than the one supplied. Current fuse F102 (shown in Figure 5-4) protects the instrument against over current.

2. Connect the circuit to be measured to the INPUT terminals and select the desired range from the five ranges available.

NOTE

The 20 μ A and 20M ranges are not operative for AC current measurements. If the 20 μ A pushbutton is inadvertently depressed, an overrange will be indicated, signalling the user to go to the next higher range. If the 20M pushbutton is depressed, the instrument will read zero.

3. Read the displayed digits and decimal point.

NOTE

AC accuracy is specified for 2000 counts and above. The method of calibrating the converter may yield an offset up to 80 digits with the Model 177 input shorted. This does not affect instrument accuracy. There will be some additional measurement error for signals with a crest

factor greater than 3 ($CF > 3$). Refer to paragraph 2.10 for information on how to determine the crest factor of a waveform.

4. Refer to paragraph 2.14 for TRMS measurements of a signal with both AC and DC current components:

2.14 TRMS MEASUREMENTS (AC + DC)

The Model 177 measures the AC component of a waveform and does not measure the DC component. Use the Model 177 to measure TRMS of a signal which has both AC and DC components as follows:

1. Measure and record the AC and DC components separately.
 - A. Refer to paragraph 2.9 for DC voltage measurement.
 - B. Refer to paragraph 2.10 for AC voltage measurement.
 - C. Refer to paragraph 2.12 for DC current measurement.
 - D. Refer to paragraph 2.13 for AC current measurement.
2. Compute the TRMS value using the following equation:

$$E_{TRMS} = \sqrt{E_{DC}^2 + E_{AC}^2} \text{ OR } I_{TRMS} = \sqrt{I_{DC}^2 + I_{AC}^2}$$

2.15 ANALOG OUTPUT

The rear panel accessible ANALOG OUTPUT provides a $\pm 2V$ full scale DC signal (10k counts = 1V). The ANALOG OUTPUT is operable for all instrument ranges and functions. The output polarity of the analog voltage is negative for the

ohms (Ω) function, positive for AC function and non-inverting for DC functions. The effective analog output resistance is $5k\Omega$ ($4k\Omega$ in series with the HI output to protect the Model 177 against externally applied voltage and $1k\Omega$ between input LO and analog output LO to prevent a ground loop when connection is made to a grounded load, oscilloscope or recorder). The analog output voltage is compatible with most modern analog recorders and may be used to determine signal changes with respect to time or other variables. With respect to the signal input and analog output, the Model 177 acts as an amplifier (for mV signals), an attenuator (for kV signals) or a converter to DC volts (for AC current or resistance signals). Output accuracy is the same as the display except on ohms; up to $\pm 0.05\%$ error can be expected due to the ratio-metric method used. The analog output floats at input LO. For this reason, do not connect a voltage source across INPUT LO and ANALOG LO. This will result in a measurement error and may damage the Model 177 if the voltage is greater than 15V. When the instrument is in an overrange condition, up to $\pm 15V$ DC may be at the ANALOG OUTPUT dependent upon the function, range and level of the input signal.

2.16 TILT BAIL ADJUSTMENT

The tilt bail of the Model 177 may be used to elevate the instrument to a convenient viewing height. To adjust the bail, pull the bail out from each side of the case and rotate it to the desired position. Release the bail to allow it to lock into position.

SECTION 3 PERFORMANCE VERIFICATION

3.1 INTRODUCTION

Performance verification may be performed upon receipt of the instrument to ensure that no damage or misadjustment has occurred during transit. Verification may also be performed whenever there is question of the instrument's accuracy, and following calibration, if desired.

NOTE

For instruments that are still under warranty (less than 12 months since date of shipment), if the instrument's performance falls outside specifications at any point, contact your Keithley representative or the factory immediately.

3.2 RECOMMENDED TEST EQUIPMENT

Recommended test equipment for performance verification is listed in Table 3-1. Alternate test equipment may be used. However, if the accuracy of the alternate test equipment is not at least 10 times better than the instrument's specifications, additional allowance must be made in the readings obtained. Some of the equipment listed in Table 3-1 is not 10 times better than the Model 177 specifications because such equipment is not readily available. In these instances, the verification procedures indicate the equipment manufacturer's specified uncertainty, and include the uncertainty in determining the allowable reading for the Model 177.

3.3 ENVIRONMENTAL CONDITIONS

All measurements should be made at an ambient temperature within the range of 18° to 28°C (65° to 82°F), and a relative humidity of less than 80%.

3.4 PERFORMANCE VERIFICATION PROCEDURE

Use the following procedures to verify the basic accuracy of the Model 177 DMM for voltage, resistance and current measurements. If the instrument is out of specification at any

point, perform a complete calibration as described in Section 5, unless the instrument is still under warranty.

NOTE

Performance verification should be performed by qualified personnel using accurate and reliable test equipment.

3.4.1 Initial Conditions

Before beginning the verification procedure the instrument must meet the following conditions:

1. If the instrument has been subjected to extremes of temperature, allow internal temperatures to stabilize for one hour minimum at the environmental conditions specified in paragraph 3.3
2. Turn on the Model 177 and allow it to warm up for one hour. The instrument may be operated from either line power or from battery pack power, as long as the battery pack has been fully charged as described in paragraph 2.6.

WARNING

Some procedures require the use of high voltage. Take care to prevent contact with live circuits which could cause electrical shock resulting in injury or death.

3.4.2 DC Voltage Accuracy Check (2V to 1200V Ranges)

1. Select DC voltage function with the AC/DC V push-buttons.
2. Connect the DC calibrator to the instrument.
3. Select the 2V range, and apply positive 2VDC to the DMM. The reading must be within the limits specified in Table 3-2.
4. Select each remaining range and apply required voltage specified in Table 3-2. Verify that the reading is within specifications.
5. Repeat all checks with negative voltage.

Table 3-1. Recommended Test Equipment For Performance Verification

Description	Specification	Mfr.	Model
DC Calibrator	0.19V, 1V, 10V, 100V, 1000V, ±0.002% or 20µV	Fluke	343A
AC Calibrator	0.1V, 1V, 10V, 100V ±0.01%	Fluke	5200A
AC Amplifier	1000V @ 0.04%	Fluke	5215
Decade Resistor	190Ω, 1.9kΩ, 19kΩ, 190kΩ, 1.9MΩ, 10MΩ, ±0.01%	ESI	RS725
Current Source	100µA, 1mA, 10mA, 100mA, 1A ±0.025%	Fluke	5100B
100Ω Per Step 4-Terminal Low Thermal Resistor	10:1 divider within 50 PPM	ESI	SR1010

Table 3-2. DC Voltage Performance Check (2V to 1200V Range)

Range	Applied Voltage	Allowable Readings at 18° to 28°C
2V	1.0000V	0.9996 to 1.0004
20V	10.000V	9.996 to 10.004
200V	100.00V	99.96 to 100.04
1200V	1000.0V	999.5 to 1000.5

3.4.3 DC Voltage Accuracy Check (20mV and 200mV Ranges)

1. Select DCV and 20mV range.
2. Disconnect test leads at the DC calibrator and short them. Adjust Model 177 front panel ZERO for a display indication of 0.000mV ± 0.001mV flashing.
3. Connect the DC calibrator and select 200mV range.
4. Set the DC calibrator to an output of +0.190000V.
5. Verify that the Model 177 reading is between + 189.89 to + 190.11mV. Note that the allowable reading includes a ±2 digit allowance for the uncertainty of the DC calibrator.
6. Repeat steps 4 and 5 with negative voltage.
7. Select 20mV range.
8. Connect the DC calibrator, low thermal resistor and Model 177 as shown in Figure 3-1.
9. Temporarily disconnect the leads from the DC calibrator and short them. Adjust Model 177 front panel ZERO for a display indication of 0.000 ± 0.001mV flashing.
10. Set the DC calibrator to an output of +0.190000V.
11. Verify that the Model 177 reading is between + 18.987 and + 19.013mV. Note, that, the allowable reading includes ±2 digits for DC calibrator uncertainty and ±1 digit for low thermal resistor uncertainty.
12. Repeat steps 10 and 11 with negative voltage.

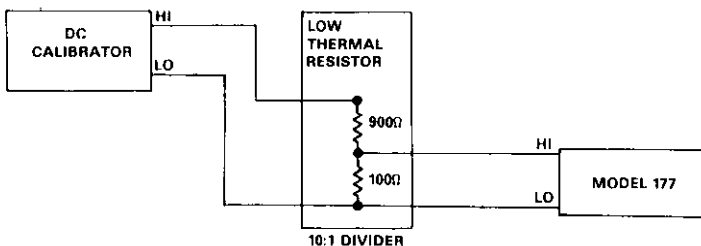

Figure 3-1. Test Circuit For 20mV DC Accuracy Check

3.4.4 AC Voltage Accuracy Check

1. Select AC voltage function with the AC/DC and V pushbuttons.
2. Connect the AC calibrator to the DMM. Set the calibrator frequency to 1kHz.

3. Set the DMM to the 200mV range and apply 100mV AC to the DMM. The reading must be within the limits specified in Table 3-3.
4. Select the 2, 20 and 200mV ranges and apply the required voltages as specified in Table 3-3. Verify that the readings are within specifications.
5. To check 1000V range, connect the AC calibrator amplifier to the output of the AC calibrator per the manufacturer's instructions. Connect the amplifier output to the Model 177 INPUT terminals. Set the AC calibrator for amplifier output of 1000.000V at 1kHz. Verify that the DMM reading is within the specified limits in Table 3-3.
6. To check accuracy at 45kHz and 20kHz, select the 20V range. Apply the voltage specified in Table 3-3 at 45Hz, then repeat at 20kHz. Verify that the DMM readings are within the specified limits.

Table 3-3. AC Voltage Accuracy Check

Range	Applied Voltage	Allowable Readings at 18° to 28°C
200mV	@1kHz	
	100.00mV	99.35 to 100.65mV
	2V	0.9935 to 1.0065V
	20V	9.935 to 10.065V
	200V	99.35 to 100.65V
1000V	1000.0V	993.5 to 1006.5V
	@45Hz	
20V	10.000V	9.915 to 10.085V
20V	@20kHz	
	10.000V	9.915 to 10.085V

3.4.5 Resistance (Ω) Accuracy Check

1. Select resistance function by depressing Ω pushbuttons.
2. Select 200Ω range.
3. Connect the decade resistor to the DMM.
4. Set the decade resistor to zero and compensate for lead resistance by adjusting front panel ZERO for a display indication 00.10 ± .01Ω flashing.
5. Set the decade resistor to 190Ω. Verify that the reading for the 200Ω range is within the limits specified in Table 3-4.
6. Select the 2kΩ range.
7. Set the decade resistor to zero and measure the resistance of the test leads. Subtract this reading from the displayed reading in all of the following steps.
8. Set the decade resistor to 1.900kΩ. Verify that the reading is within the limits specified in Table 3-4.
9. Continue by selecting the next range and measure the next resistance as specified in Table 3-4. Test each item in the table and verify that each reading is within specifications.

Table 3-4. Resistance Accuracy Check

Range	Resistance	Allowable Reading at 18° to 28°C	*
200Ω	190Ω	189.86 to 190.14Ω	± 2 digits
2kΩ	1.900kΩ	1.8989 to 1.9011kΩ	± 2 digits
20kΩ	19.000kΩ	18.989 to 19.011kΩ	± 2 digits
200kΩ	190.00kΩ	189.89 to 190.11kΩ	± 2 digits
2000kΩ	1900.0kΩ	1898.9 to 1901.1kΩ	± 2 digits
20MΩ	10.000MΩ	9.988 to 10.012MΩ	± 1 digit

*Manufacturer's specified uncertainty of the decade resistor in digits. This uncertainty has been added to the specified accuracy of the Model 177 to obtain the allowable reading.

3.4.6 DC Current Accuracy Check

1. Select the DC current function with the AC/DC and A pushbuttons.
2. Select the 20μA range. With an open circuit at the INPUT terminals of the Model 177, adjust the front panel ZERO for a display indication of 0.000 ± 0.001μA flashing.
3. Connect the DC current source to the DMM.
4. Select each range and apply the required current as specified in Table 3-5. Verify that each reading is within specification.

Table 3-5. DC Current Accuracy Check

Range	Applied Current	Allowable Reading at 18° to 28°C
200μA	100.00μA	99.79 to 100.21μA
2mA	1.0000mA	0.9979 to 1.0021mA
20mA	10.000mA	9.979 to 10.021mA
200mA	100.00mA	99.79 to 100.21mA
2000mA	1000.0mA	997.9 to 1002.1mA

3.4.7 Analysis

If the instrument is out of specified limits at any point in Table 3-2 through 3-5, calibrate the DMM as described in Section 5. If the unit is still under warranty, refer to the note in paragraph 3.1.

NOTE

It is not necessary to specifically check the 20Ω or 20μA ranges, or any of the ACA ranges. The circuit components that determine their accuracy have been checked elsewhere in the verification procedure.

SECTION 4 THEORY OF OPERATION

4.1 INTRODUCTION

This section contains circuit descriptions for the Model 177 DMM and the optional Model 1788 Battery Pack. An overall block diagram of signal flow is provided in Figure 4-1. The schematic diagrams are contained in Section 6 of this manual. The Model 177 schematic is drawing number 29658E and schematic drawing number 29659C is for the Model 1788.

4.2 OVERALL OPERATION

The Model 177 uses a 2V (20,000 count) full scale analog-to-digital (A/D) converter with a 4½ digit multiplexed display. Signal conditioning permits the A/D converter to accommodate full scale DC voltage and current measurements over seven ranges.

4.2.1 Signal Conditioning

Signal conditioning includes: DC attenuation (on the 20, 200 and 1200V ranges), modulation and demodulation of the DC signal by the chopper buffer/amplifier with X100 and X10 gain (on the 20 and 200mV ranges, respectively), AC attenuation (on the 20, 200 and 1000V ranges), AC amplification (on the 200mV and 20V ranges), AC-to-DC conversion, ohms source and conversion, and current shunts as shown in Figure 4-1.

1. In the DCV mode, signal conditioning to the A/D converter consists of range and function switching, range resistors (attenuator) and the chopper buffer/amplifier. For all ranges, the DC input signal is attenuated/amplified to provide a $\pm 2V$ full scale output to the A/D converter. In the DCA mode, the voltage developed across the shunt resistor is applied directly to the input of the chopper amplifier. A chopper gain of X10 is used for all ranges except 20A which uses X100.

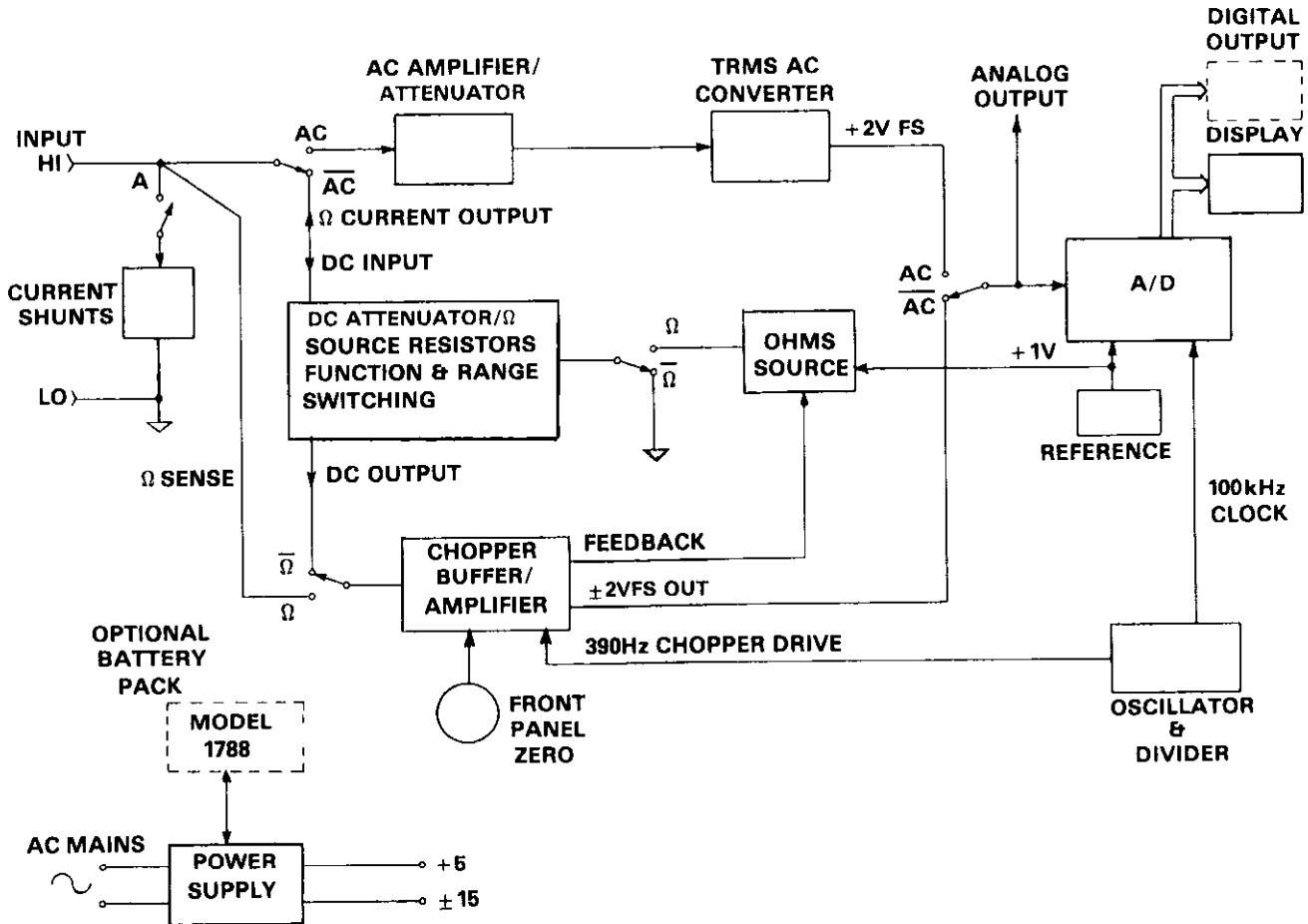

Figure 4-1. Model 177 Simplified Signal Flow Block Diagram

2. In the ACV mode, AC inputs for all ranges pass through the AC converter which consists of an amplifier/attenuator and a TRMS converter, as shown in Figure 4-2. The AC input is scaled by the amplifier/attenuator to 2V rms full scale for all ranges. The TRMS converter provides a positive DC output signal which is proportional to the true root mean square AC signal. This DC signal is the input to the A/D converter. In the ACA mode, the shunt voltage is applied to the input of the AC converter. The amplifier/attenuator provides a $\times 10$ gain for all AC current ranges.
3. Ohms conversion—Resistance measurements are made by supplying a constant current from the ohms converter to the unknown resistor (R_x). The resulting voltage developed across the unknown resistor is proportional to its resistance, and this voltage is applied to the input of the chopper amplifier used for DC volts. The chopper amplifier output to the A/D converter is scaled to -2V full scale for all ohms ranges. Scaling of the ohms signal over the seven ranges is accomplished by using five constant current levels and the three gains of the chopper amplifier.

4.2.2 A/D Converter

The A/D converter is a large scale integration (LSI) ratiometric device. Converter output is a multiplexed five digit number, in binary coded decimal (BCD) form which is equal to the ratio of the input voltage to the reference voltage. A separate clock circuit supplies a 100kHz timing input to the integrated circuit, which also multiplexes the BCD output. The full scale A/D input for all ranges of the Model 177 is 2VDC, with the polarity determined by the function as follows: ACV and ACA, +2V; DCV and DCA, $\pm 2V$; Resistance (Ω), -2V.

4.2.3 Range Switching

It is important to note that the range switches on schematic 29658E are identified by the front panel marking for the Ω ranges. The corresponding V and A ranges may either be determined from the instrument front panel or by using Table 4-1.

4.3 AC CONVERTER

When making AC voltage measurements, the AC converter scales the input signal by appropriate attenuation or amplification, performs TRMS conversion and provides the equivalent positive DC level to the A/D for display. Input resistance for AC volts is 1M Ω (R107). Shunt capacitance is less than 75pF. Signal conditioning is as follows:

4.3.1 Scaling

Scaling is performed in the first two stages, as shown on schematic drawing number 29658E and summarized in Table 4-2. Scaling is performed by using a relay and FET switches to switch feedback resistors in the attenuator (U101) and the amplifier (U102). The actual gains used in attenuator U101 are 0.99, 0.0099 and 0.00099. Amplifier U102 gains are nominally 1.003 and 10.03. The combined gain of U101 and U102 is offset low to permit gain adjustment in the TRMS stage. The only adjustments provided in the attenuator and amplifier stages are two high frequency compensation capacitors (C102 and C103). AC coupling is used at the input and output of the attenuator and amplifier stages. Input overload protection is provided by diodes (CR106 and CR107) and resistors R107 (1M Ω , 2W).

4.3.2 AC Conversion

AC-to-DC conversion is performed by a monolithic TRMS module (U103). Output $V_{DC} = \sqrt{Avg (V_{in})^2}$. Averaging and output filtering are done before the internal output buffer to give a low impedance for the analog output. Potentiometer R113 provides midband (10K count) gain adjustment and R114 establishes output zero (1K count). Capacitor C108 is used in the averaging circuit, and C109 provides filtering as described above.

4.3.3 AC Current Measurements

For AC current measurements, the appropriate shunt resistor is placed in front of the AC converter. The 200mV range gain configuration is used for all current ranges.

4.4 DC SIGNAL CONDITIONING

For DC voltage measurements, the input resistance is 10M Ω , which is established by all of the range resistors being connected in series to signal ground. On low voltage ranges, the DC input is applied to the top of the resistive divider (range resistor) and to the buffer amplifier input without attenuation. Also, the chopper amplifier has appropriate gain to provide a $\pm 2V$ full scale output to the A/D. On high voltage ranges, the DC signals are scaled down to $\pm 2V$ full scale by the resistive divider and the chopper is used in the unity-gain (follower) mode as a buffer. A summary of input attenuation and chopper amplifier gain is given in Table 4-3.

Table 4-1. Range Switch Correlation

Function	Ranges						
	Ω	20	200	2k	20k	200k	2000k
V	20m*	200m	2	20	200	1000**	
A	20 μ *	200 μ	2m	20m	200m	2000m	

*DC Only

**ACV 1000, DCV 1200

Table 4-2. Converter Attenuation and Amplification

Range	Attenuator (U101)	Amplifier (U102)
200mV	÷ 1	× 10*
2V	÷ 1	× 1
20V	÷ 100**	× 10*
200V	÷ 100**	× 1
1000V	÷ 1000***	× 1

* × 10 = Q102 Off
 ** × 100 = Q101 On
 *** × 1000 = K101 On

Table 4-3. DC Signal Conditioning Attenuation and Gain

Range	Input Attenuation	Chopper Gain
20mV	—	× 100
200mV	—	× 10
2V	—	× 1
20V	÷ 10	× 1
200V	÷ 100	× 1
1200V	÷ 1000	× 1

4.4.1 Input Attenuation

On the 20, 200 and 1200V ranges, the input signal is attenuated by the resistive divider to divide by 10, 100 and 1000, respectively. Depressing one of the above range push-buttons, interrupts the unattenuated signal from the volts switch pin 17 and connects the wiper of the appropriate range potentiometer to the input of the chopper. Division by 10, 100 and 1000 is accomplished by connecting the wiper of the R155, R156 or R157, respectively.

4.4.2 Chopper

The input signal to the chopper is filtered and applied to a modulator circuit. The AC signal is then amplified and demodulated. A final high gain DC amplifier provides a DC signal to the A/D converter and the analog output.

1. Modular Circuit—This circuit converts the input DC signal to an AC signal with a fundamental frequency component of approximately 390Hz. This frequency was chosen because it reduces the amplitude of higher harmonics of the 50Hz and 60Hz line frequencies, which minimizes beating. The circuit utilizes a dual MOSFET (Q104A and Q104B) connected in a series-shunt configuration to maintain the required high input impedance.
2. AC Amplifier—The AC amplifier uses a JFET-input operational amplifier (U108). The amplifier feedback network provides a gain of approximately 133 at the modulating frequency of 390Hz, while maintaining a gain of one for amplifier (U108) DC offset voltages.

AC CONVERTER

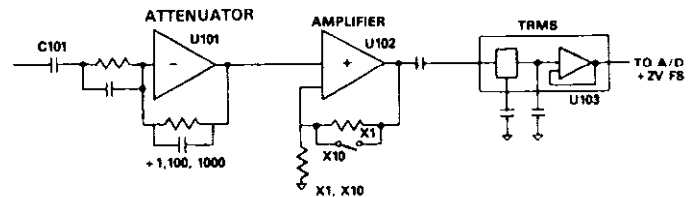

CHOPPER

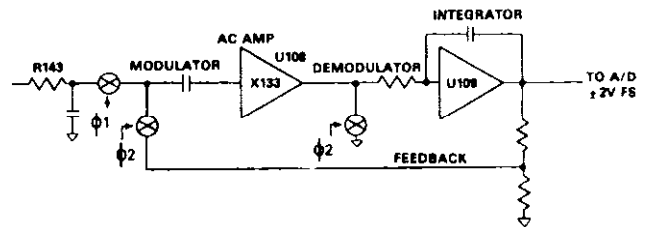

OHMS CONVERTER

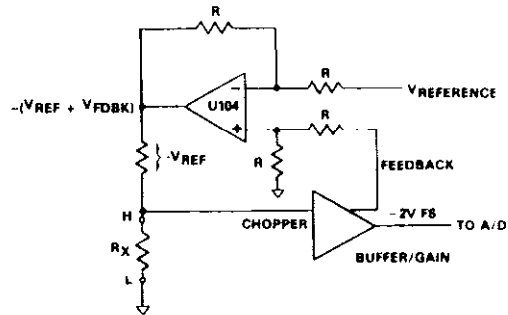

Figure 4-2. Simplified Signal Conditioning

3. Demodulator Circuit—The demodulator is synchronized with the input modulator. A JFET (Q105) with low on-resistance is used to alternately attenuate and pass the signal present at the output of AC amplifier U108. This produces a "half-wave rectified" DC signal at the input of the integrator stage, that is inverted with respect to the chopper input signal.
4. DC Amplifier—Amplifier (U109) is connected as an integrator with an offset adjustment. U109 provides sufficient gain to bring the total open-loop DC gain to about one million. U109 drives the feedback divider network and the A/D converter, and provides the low output impedance necessary to drive the analog output. Feedback capacitor (C138) was selected to provide nominal settling time, while meeting NMR requirements. When the chopper is operating as a unity-gain follower, the DC signal present at the output of U109 is the chopper feedback. This is the condition for the 2VDC range and above. On the 200mV and 20mV ranges, where chopper gains of 10 and 100 are required, the resistive divider feeds back a portion of the output of U109 to provide the required gain.
5. Modulator-Demodulator Drive Circuit—CMOS inverters (U111A and U111F) provide opposite phase 0 to -15V square waves used to drive MOSFET modulator transistors Q104A and Q104B. Inverter U111F also drives the

demodulator JFET Q105. Resistors R118, R119 and R142 and capacitors C131 and C132 affect the rise and fall times of drive signals. R142 adjusts the rise and fall time of the drive signal to Q104A only, so that the total charge, both positive and negative, transferred to the input can be minimized. The frequency of the drive signal is determined by the clock circuit. Circuitry in U110 divides down a nominal clock frequency of 100kHz to produce 390Hz.

6. Adjustments and Input Protection—The front panel zero control (R203) permits adjustment of the chopper feedback to compensate for input thermal EMFs. It functions only on ranges where chopper gain is greater than one. A span of $\pm 75V$ is considered adequate; however, it is typical for R203 to provide a greater than 400V change as it is turned end-to-end. The span is skewed by R128 to give best resolution in both DCV and Ω . Potentiometer R146 provides a calibration adjustment to compensate 200mV range (X10 gain configuration) and R147 adjusts the X100 gain used on the 20mV range. Chopper input resistor R143 limits the input current during momentary input overloads to 12mA, which is then absorbed by the chopper load resistance (R145 and/or R149) or the power supplies through CR116 and CR117.
7. DC Current Measurements—As previously described, DC current measurements are made by placing the appropriate buffer/amplifier shunt resistor on the chopper input. A chopper gain of X10 is used for all current ranges except 20A, which uses X100. The front panel zero control (R203) is functional for all DC current ranges.

4.5 OHMS CONVERSION

The ohms converter contains two sections: a floating current source and a high input impedance buffer/amplifier. The chopper employed as a buffer/amplifier in DCV is also used as the high impedance buffer/amplifier for Ω . Refer to paragraph 4.4 for additional chopper theory.

4.5.1 Floating Current Source

The floating current source involves a differential amplifier (U107) driven by the A/D reference voltage and the chopper feedback voltage. This results in a constant voltage across the source resistance ($= -V$ reference) which results in a constant current in the unknown resistance. One or more range resistors are always connected as the ohms source resistor (R_S) when ohms function is selected. Five different constant current levels are supplied by changing the value of R_S with the range pushbuttons. These levels are given in Table 4-4. For Ω , INPUT HI terminal is negative with respect to INPUT LO.

4.5.2 Chopper

For ohms, the full scale chopper output is -2V. Gain is employed on the 20 Ω and 200 Ω ranges to give -2VFS out with the nominal 1mA source current. The front panel zero control functions on these two ranges, allowing compensation for up

to 200m Ω of lead resistance. Settling time is determined primarily by chopper input ($T = R_S C$) which results in two seconds to full scale on the 2000k Ω and 20M Ω ranges. (.047 $\mu F \times 2M\Omega$ and .0047 $\mu F \times 20M\Omega$).

Table 4-4. Ohms Conversion

Range	R_S Source Resistance	Chopper Gain	Nominal Current
20	1k	$\times 100$	1mA
200	1k	$\times 10$	1mA
2k	1k	$\times 1$	1mA
20k	10k	$\times 1$	100 μA
200k	100k	$\times 1$	10 μA
2000k	1M	$\times 1$	1 μA
20M	10M	$\times 1$	0.1 μA

4.5.3 Adjustments and Input Overload Protection

Two Ω source calibration adjustments are required. Potentiometer R162 compensates primarily for the tolerance of R_S (R158), while R159 compensates for ratio variations in the four gain resistors (R150 through R153). The protection network at the source output isolates the amplifier from positive voltage overloads (Q103) and negative voltage overloads (CR120) applied to INPUT HI. Transistor Q107 clamps the source input during overload. The ratio of the base to emitter resistors on Q103 sets the open circuit voltage.

4.6 ANALOG OUTPUT

The rear panel ANALOG OUTPUT provides a $\pm 2V$ full scale DC output signal (10K counts = 1V). The analog output signal is available on all instrument functions and ranges, with a negative polarity on ohms (Ω) and a positive polarity on AC. The output is unbuffered, supplied by either the chopper or the TRMS converter through 5k Ω effective resistance, with 1k Ω placed in the LO leg to prevent ground loops through INPUT LO.

4.7 CLOCK

A single chip CMOS oscillator/ $\pm 2^N$ package is used to generate the 100kHz A/D clock and the 390Hz chopper drive signals. The 100kHz 0V to 5V signal drives the A/D and battery pack directly. The 390Hz signal is level shifted to 0V to -15V and split into two phases for driving the chopper FETs. An RC adjustment (R142) provides chopper input bias current compensation. Balancing and guarding is employed to keep the drive signal out of the chopper AC amp stage.

4.8 A/D CONVERTER

The A/D converter operates on the dual slope principle. The timing is divided into three periods as described below.

4.8.1 Auto-Zero

The auto-zero period (Figure 4-3) is 100mS in length, which corresponds to 10,000 clock pulses. During this period, the reference voltage (V_{REF}) is stored on capacitor C116. Capacitor C115 stores $V_{REF} + V_{OS1} - V_{OS2}$.

4.8.2 Signal-Integrate

The signal-integrate period (Figure 4-3) is also 100mS in length. The A/D input is buffered and integrated by U105. Positive signals generate a negative-going ramp at the integrator output (pin 14), while negative signals produce a positive-going ramp. The level of the integrated signal at the end of the signal-integrate period is proportional to the average of the applied signal during this period. Since signal integration continues for 100mS, the A/D converter exhibits high normal mode rejection for AC signals in multiples of 10Hz, particularly the 50 and 60Hz line frequencies.

4.8.3 Reference-Integrate

The reference-integrate period for a full scale input (Figure 4-3) is 200mS, or 20,000 counts in length. During this period, the integrator is returned to baseline level by applying a reference voltage of a polarity opposite to that of the signal. A positive-going ramp is obtained by grounding the buffer input, while a negative-going ramp is produced by the integration of $2 \times V_{REF}$ (that is, $V_{REF} +$ the voltage stored in C116). The time, or number of clock pulses, required for discharge is proportional to the signal input. Digital output is from latches within U106 which store the number of clock pulses required for the integrator to return to baseline level. The maximum count during this period is 20,000 which corresponds to a discharge period of 200mS, or full scale input. For an input of less than full scale, the A/D automatically reverts to auto-zero for that period of the 200mS remaining after return to baseline level. V_{REF} is provided by a divider across a temperature-compensated zener diode. Operational amplifier U104 provides the zener with a self-regulating bias.

A. AUTO-ZERO (10k COUNTS)

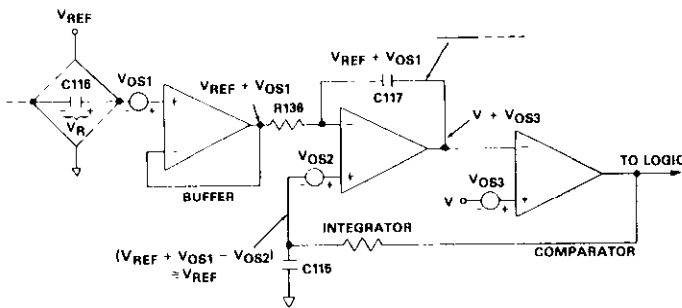

C. NEGATIVE REFERENCE INTEGRATE (20k COUNTS AT FULL SCALE) (POSITIVE INPUTS-TO A/D)

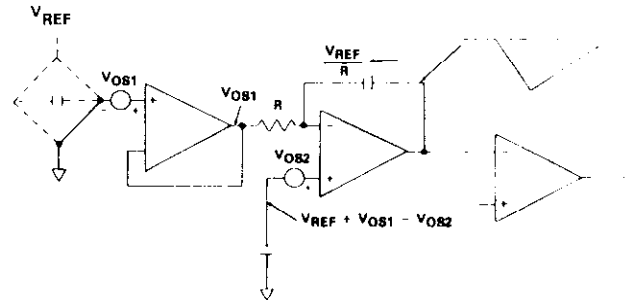

B. SIGNAL INTEGRATE (10k COUNTS)

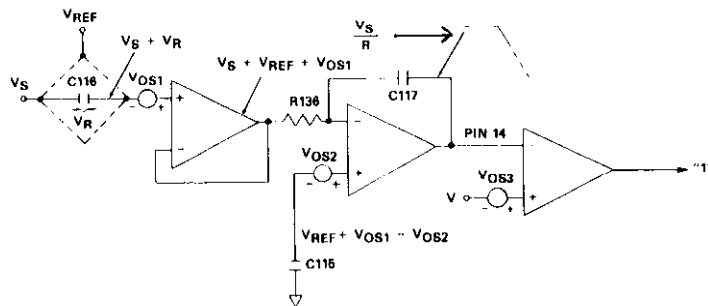

D. POSITIVE REFERENCE INTEGRATE (20k COUNTS AT FULL SCALE)

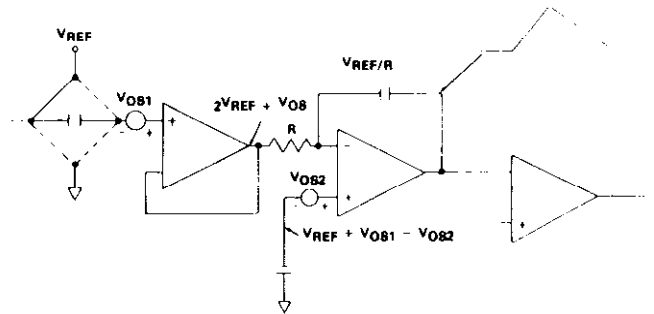

Figure 4-3. A/D Converter Function

4.9 DISPLAY

Five light-emitting diodes (LED) are driven by U203, which is a CMOS BCD-to-seven segment decoder/driver with bipolar current-sourcing outputs. Segment currents are limited to approximately 20mA peak by resistor network R202. The LED readout is a multiplexed, common-cathode configuration with Darlington array U202 sequentially sinking current from each digit. Blanking of the overrange digit is accomplished by gates U104C and U104D. U104A and U104B ensure that CMOS-compatible levels are maintained on U104D, regardless of the loading of U202. The minus polarity readout is blanked on AC voltage and resistance ranges by normally open contacts on the AC and Ω pushbuttons.

4.10 AC POWER SUPPLY

When the Model 177 is operated from AC line power, the power supply furnishes +5, +15, and -15V from regulators VR101, VR102 and VR103, respectively. Full-wave rectified AC from bridge rectifiers CR103 and CR104 is filtered by capacitors C120, C123 and C125 and is applied to the linear voltage regulators.

4.11 MODEL 1788 BATTERY PACK

When the Model 1788 Battery Pack is installed in the Model 177, S102 must be set to the BAT position to provide additional secondary voltage for battery charging. S102 also switches the input to VR101 from bridge rectifier CR103 to batteries BT301. Four 2V, 2.5 ampere-hour lead-acid cells supply approximately 9.8V at full charge. After six hours of use on battery power, the battery pack should be recharged to ensure long battery life.

4.11.1 Battery Charging Circuit

While the Model 177 is plugged into line power and the battery pack is installed, battery charging proceeds as follows:

1. Full-wave rectified from CR103 is applied to the anode of Q301, which is an SCR which regulates charging voltage. When Q301 is triggered on by a sufficient gate-cathode voltage differential, the batteries receive charge. Charging continues as long as the bridge output voltage exceeds battery voltage by 1V or more. Resistor

R304 limits charging current when recharging a set of completely discharge cells, a filtered positive output from CR104 (or T301) provides the necessary gate turn-on bias through R306 and diode CR301. Resistor R303 ensures proper high-temperature operation of Q301.

2. When the battery voltages reach the present float voltages of 9.8V, zener VR301 conducts sufficient current to turn on Q302 and thus remove the gate trigger voltage from Q301. Float voltage is adjusted with R301. This is a factory adjustment which will normally not need field readjustment.

4.11.2 Battery Operation and Shutdown Circuit

The Model 177 operates as follows on battery power:

1. When the power is turned on, the batteries are connected to the input of VR101 to supply +5V for the logic, display and the clock circuit. The clock output is applied to the A/D converter as described in paragraph 4.7, and U301 which is a divide-by-four binary counter. The outputs of U301 drive a DC-to-DC inverter which is synchronized to the A/D converter to filter out inverter noise. The 25kHz operating frequency is optimal for the small transformer size and results in low switching losses. Blocking capacitors C301 and C302 protect Q307 and Q308 from damage if the drive is lost. Two half-wave rectifiers (CR304 and CR305) on the secondary of T301 provide rectified AC to filter capacitors C304 and C305, which provide power to +15 and -15V regulators VR102 and VR103, respectively.
2. To prevent permanent loss of battery capacity caused by deep discharge, a shutdown circuit stops operation on battery power when the battery voltage drops below approximately 7.2V. Shutdown is performed by micropower voltage detector U302. The open-collector output (U302, pin 4) saturates low and turns off pass transistor Q309 when the input voltage (at U302, pin 3) drops below 1.15V (typical). Resistor R314 provides sufficient hysteresis to prevent discharge from resuming when the battery voltage rises following disconnection of the load.

SECTION 5 MAINTENANCE

5.1 INTRODUCTION

This section contains information necessary to maintain the Model 177 and Model 1788 Battery Pack. Information concerning adjustment/calibration, troubleshooting, front panel zero knob removal and replacement, and fuse replacement are contained in this section. Calibration should be performed yearly (every 12 months) or whenever performance verification (see Section 3) indicates that the Model 177 is out of specifications. If any step in the calibration procedure cannot be performed properly, refer to troubleshooting information in this section, or contact your Keithley representative or the factory.

NOTE

Calibration should be performed by qualified personnel using accurate and reliable test equipment.

5.2 RECOMMENDED TEST EQUIPMENT

Recommended test equipment for calibration is listed in Table 5-1. Alternate test equipment may be used. However, the accuracy of the alternate test equipment must be at least 10 times better than the Model 177 specifications, or equal to Table 5-1 specifications.

5.3 ENVIRONMENTAL CONDITIONS

Calibration should be performed under laboratory conditions having an ambient temperature of 20°C to 26°C (68°F to 78°F), and a relative humidity of less than 80%. If the instrument has been subjected to temperatures outside of this range, or to higher humidity, allow one hour minimum for the instrument to stabilize at the specified environmental conditions before beginning the calibration procedure.

5.4 CALIBRATION PROCEDURE

Perform the following adjustments to calibrate the Model 177 and restore its operation to specified limits.

Table 5-1. Recommended Test Equipment For Calibration

Description	Specification	Mfr.	Model
DC Calibrator	0.1V, 1V, 10V, 100V, 1000V ±0.002%	Fluke	343A
AC Calibrator	0.1V, 1V, 10V, 100V, ±0.01%	Fluke	5200A
Decade Resistor	500Ω, 1.9kΩ, 190kΩ, ±0.01%	ESI	RS725
100Ω Per Step 4-Terminal Low Thermal Resistor	10:1 divider within 50 PPM (See Figure 3-1)	ESI	SR1010

5.4.1 Calibrating Shield Installation

If the Model 1788 Battery Pack is installed in the instrument it must be removed and the calibration shield reinstalled before calibration. If the calibration shield has been lost or misplaced, order Keithley Part Number 29473.

WARNING

Disconnect the line cord before removing the case cover.

1. Turn off the power and disconnect the line cord. Remove four screws from the bottom of the case and separate the top cover from the bottom cover.
2. Push back the ground clip from the upper side of the battery pack and remove the battery pack from the spacers.
3. Calibration may be performed on battery power as long as the battery pack is sufficiently charged. Leave the battery pack plugged into the instrument, but set the battery pack behind the Model 177 on the bench or table. Ensure that LINE/BAT switch (S102) is in BAT position.
4. Set the calibration shield in place on the spacers. The shield should read correctly when viewed from the front of the instrument.
5. Slide the ground clip over the top of the calibration shield so that it contacts the upper surface of the shield.
6. If the battery power is not to be used, plug in the line cord and position S102 to the LINE position if the battery pack has been disconnected.

5.4.2 Warm-Up

Turn the Model 177 on and allow a one hour warm-up time.

5.4.3 Calibration Instructions

WARNING

Some procedures require the use of high voltage. Take care to prevent contact with live circuits which could cause electrical shock resulting in injury or death. Use an insulated tool when making adjustments.

1. Refer to Table 5-2 and perform the listed adjustments in the sequence indicated on the calibration shield by boxed numerals. The sequence must be followed exactly because the adjustments are interrelated and dependent on the preceding steps. The step sequence (box numerals) is also shown on schematic diagram 29658E.
2. If the indicated adjustment cannot be made to obtain the specified reading, refer to troubleshooting information in this section.

5.5 TROUBLESHOOTING

The troubleshooting instructions contained in this section are intended for qualified personnel having a basic understanding of analog and digital electronic principles and components used in a precision electronic test instrument. Instructions have been written to assist in isolating the defective circuit or subcircuit. Isolation of the specified defective component has been left to the technician.

NOTE

For instruments that are still under warranty (less than 12 months since date of shipment), if the instrument's performance is outside of specifications at any point, contact your Keithley representative or the factory before attempting troubleshooting or repair, other than fuse replacement.

5.6 TROUBLESHOOTING PROCEDURE

This section contains tables listing step-by-step checks of the major Model 177 circuits described in Section 4, Theory of Operation. The following steps outline the use of these tables and provide instructions for preparing the Model 177 for troubleshooting. Read all of these steps carefully before troubleshooting the instrument.

5.6.1 Calibration Shield/Battery Pack Removal

If the Model 1788 Battery Pack (or calibration shield) is installed, it must be removed to gain access to test points and circuit components for troubleshooting.

WARNING

Disconnect the line cord before removing the case cover.

1. Turn off power and disconnect the line cord. Remove the four screws from the bottom of the case and separate the top cover from the bottom cover.
2. Push back the ground clip and remove either the calibration shield or battery pack from the spacers. If operation on battery power is to be checked, leave the battery pack plugged into the instrument, but set the battery pack behind the Model 177 on the bench or table.

Table 5-2. Calibration Procedure

Step	Function	Range	Input	Adjustment Point	Desired Reading	Test Equipment
1	DC V	2V	Short	R163	.0000/- .0000	None
2	DC V	2V	Open	R142	.0000/- .0000	None
3	DC V	2V	Short	R163	.0000/- .0000	None
4	DC V	2V	Open	R142	.0000/- .0000	None
5	DC V	2V	+ 1.9V	R134	1.9000	DC Calibrator
6	DC V	20mV	Short	R203	.0000/- .0000	None
7	DC V	200mV	+ 190mV	R146	190.00	DC Calibrator
8	DC V	20mV	+ 19mV	R147	19.000	DC Calibrator and 10:1 Divider
9	Ω	2k Ω	500 Ω	R162	.4999/ .5000	Decade Resistor
10	Ω	2k Ω	1.9k Ω	R159	1.9000	Decade Resistor
11	Ω	2k Ω	500 Ω	R162	.4999/ .5000	Decade Resistor
12	Ω	2k Ω	1.9k Ω	R159	1.9000	Decade Resistor
13	Ω	200k Ω	190k Ω	R156	190.00	Decade Resistor
14	DC V	200V	+ 190V	R139	190.00	DC Calibrator
15	DC V	20V	+ 19V	R155	19.000	DC Calibrator
16	DC V	1000V	+ 1000V	R157	1000.0	DC Calibrator
17	AC V	2V	.1V @ 1kHz	R114	.1000	AC Calibrator
18	AC V	2V	1V @ 1kHz	R113	1.0000	AC Calibrator
19	AC V	2V	.1V @ 1kHz	R114	.1000	AC Calibrator
20	AC V	2V	1V @ 1kHz	R113	1.0000	AC Calibrator
21	AC V	200V	100V @ 20kHz	C102	100.00	AC Calibrator
22	AC V	2V	1V @ 20kHz	C103	1.0000	AC Calibrator

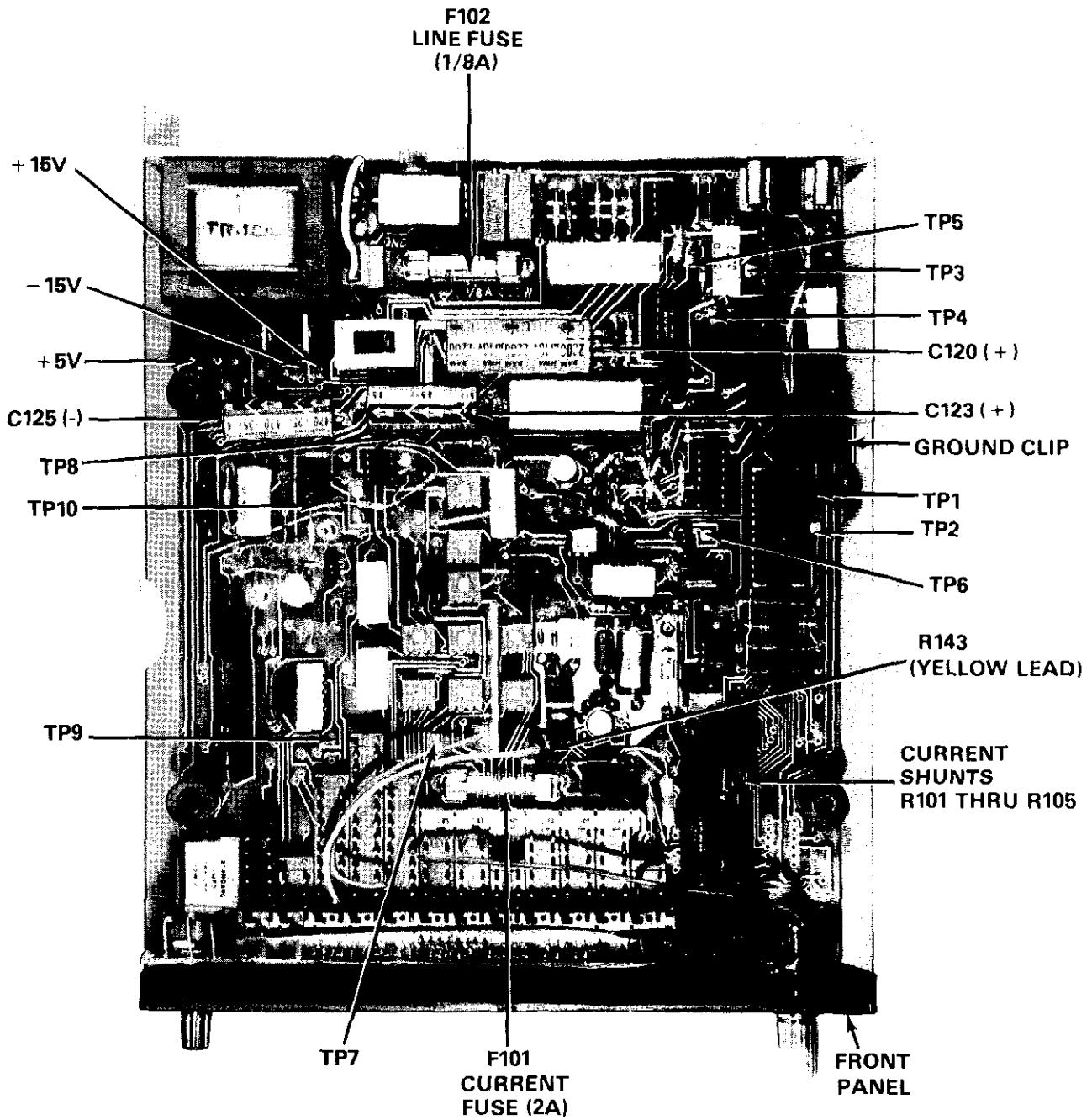

Figure 5-1. Test Point Locations

5.6.2 Line Power

In general, start troubleshooting with Table 5-3, line power checks, to verify that the power supplies are providing the correct voltages to the electronic components.

5.6.3 Battery Power

If trouble occurs on battery power only, or if battery operating time is substantially less than six hours after overnight charging, test the batteries and charging circuit per Table 5-4.

5.6.4 Display and A/D Converter

Proper operation of the A/D converter and display should be verified before troubleshooting the signal conditioning circuits. Check the A/D converter and display per Table 5-5 and 5-6, respectively.

5.6.5 AC Converter

Problems with AC voltage or AC current ranges may involve the AC converter. Check this circuit per Table 5-7. If the problem is only on AC current ranges, see below.

5.6.6 Chopper Amplifier and Ohms Source

Problems with DC voltage, DC current, or resistance ranges may involve the chopper amplifier. Check this circuit per Table 5-8. After verifying chopper amplifier operation by completing steps 1 through 10 of Table 5-8, go to Table 5-9 if resistance measurements are erratic. If problem is only on DC current ranges, see below.

NOTE

Dust, flux or other contamination will degrade performance on resistance and DC voltage ranges.

5.6.7 Current Shunts

If problems occur with current readings, check the current shunts and related circuitry per Table 5-10. It should be noted that, since the current shunts are common to both AC and DC current, problems should exist on the same AC and DC current ranges if there is a fault in the current shunt circuitry.

NOTE

All measurements are referenced to analog common (ground clip), unless otherwise noted in the Tables.

If a gross failure exists that indicates a possible blown fuse (line power, battery pack, or current fuse) refer to paragraph 5.8 for fuse replacement instructions.

WARNING

Some procedures in the following tables require the use of high voltage. Take care to prevent contact with live circuits which could cause electrical shock resulting in injury or death.

5.7 FRONT PANEL ZERO KNOB REMOVAL AND REPLACEMENT

The front panel ZERO knob will have to be removed if either the front panel or display is to be removed. To remove the knob, proceed as follows:

1. Carefully remove the end-cap (shown in Figure 5-3) using a thin-bladed instrument.
2. Loosen the slotted screw and remove the knob from the shaft.
3. Take care not to damage or lose either the end-cap or knob. These items provide protection against electrical shock and must be installed when the instrument input is floating.

NOTE

If the display board has to be removed for troubleshooting or repair, the front panel ZERO knob will also have to be removed.

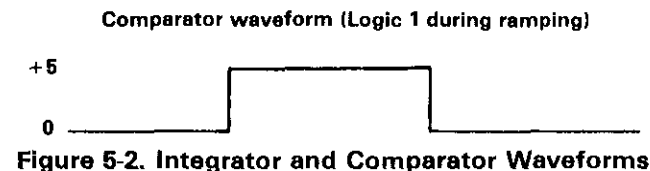
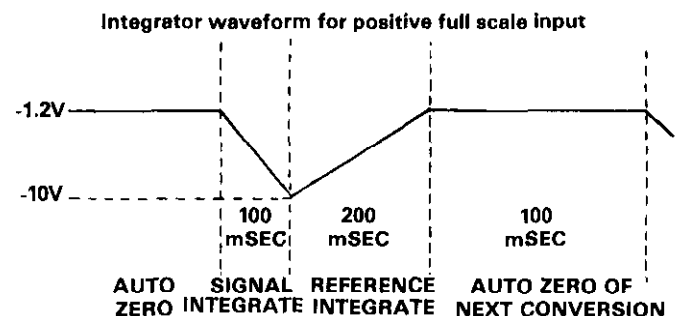

Figure 5-2. Integrator and Comparator Waveforms

WARNING

The ZERO potentiometer shaft is electrically connected to INPUT LO. Maintain INPUT LO at ground potential while the ZERO knob or its cap is removed to prevent an electrical shock hazard.

4. To replace the knob, reverse the preceding steps. Do not substitute any other knob. If the knob or its cap is lost or damaged, order only Keithley part number KN-41-1 as a replacement.

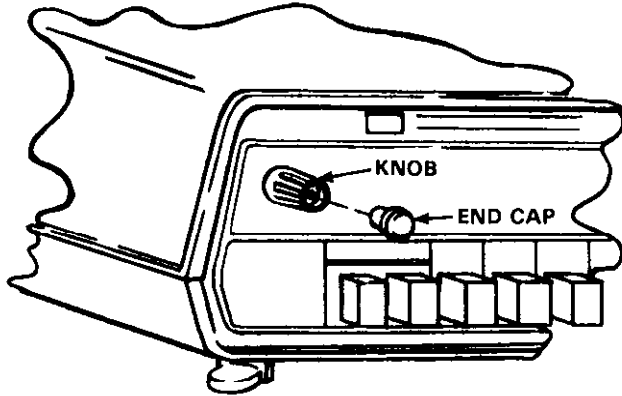

Figure 5-3. Front Panel Zero Knob Removal

fuse, proceed as follows:

WARNING

Disconnect the line cord before removing the case cover.

1. Turn off power and disconnect the line cord.
2. Turn the Model 177 bottom side up and loosen the four screws in the bottom cover. These screws are held captive by rubber O-rings.
3. Hold the top and bottom covers together to prevent their separation and turn the Model 177 over to normal position.
4. Lift off the top cover.

CAUTION

Do not install fuses with higher ratings than specified. Instrument damage may occur.

5. Replacement of battery pack fuse F301:
 - A. Leave the battery pack in place and connected.
 - B. Remove F301, shown in Figure 5-4, and replace it with a 2A, 250V, 3AG fuse (Keithley part number FU-13).

5.8 FUSE REPLACEMENT

All fuses are located internally in the Model 177. To replace a

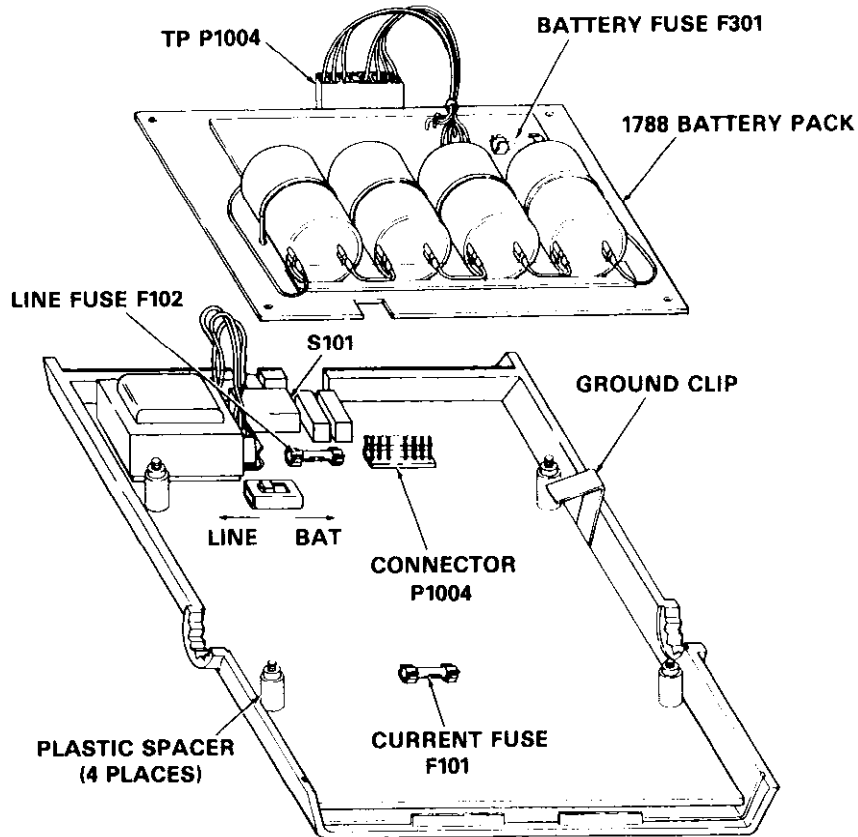

Figure 5-4. Battery Pack Installation

6. Replacement of line power fuse F102:
 - A. Once the top cover is removed, F102 is accessible without removing any other components.
 - B. Remove F102, shown in Figure 5-1, and replace it with a 1/8A, 250V, 3AG, SLO-BLO fuse (Keithley part number FU-20) for standard line voltage units. Optional line voltage units with 90-110V and 190-210V ranges, use a 3/16A, 250V 3AG SLO-BLO fuse (Keithley part number FU-29).
7. Replacement of current fuse F101:
 - A. Lift the calibration cover, or battery pack, off of the spacers to gain access to the current fuse.
 - B. Remove F101, shown in Figure 5-1, and replace it with a 2A, 250V, 3AG fuse (Keithley part number FU-13).
 - C. Install calibration shield or battery pack on the spacers. Be sure that the ground clip, shown in Figure 5-1, is positioned on the top side of the shield or battery pack.
8. Reinstall the top cover.
3. Hold the top and bottom covers together to prevent their separation and turn the Model 177 over to normal position.
4. Lift off the top cover and the calibration shield. The four plastic spacers must remain in place on the upright studs projecting through the main printed circuit board.
5. Set the BAT/LINE switch to the BAT position shown in Figure 5-4. Note that the battery pack will not operate properly if this switch is not in the BAT position.
6. Remove the fuse F301 on the battery pack.
7. Install the battery pack in the instrument so that it rests on the plastic spacers. The ground clip must make contact with the upper side of the battery pack plate.
8. Carefully align the battery pack plug with connector P1004 on the circuit board. Push the plug firmly onto the connector until the lip on the plug engages the lip of the connector to lock the plug in place.

CAUTION

Make sure the connector is aligned so that all pins mate properly, otherwise, damage to the Model 177 and battery pack will result.

5.9 MODEL 1788 BATTERY PACK INSTALLATION

WARNING

Disconnect the line cord before removing the case cover.

1. Turn off the power and disconnect the line cord.
2. Turn the Model 177 bottom side up and loosen the four screws in the bottom cover. These screws are held captive by rubber O-rings.
9. Install the fuse F301. Reinstall top cover and secure with four screws.
10. Charge the battery pack as described in paragraph 2-6.

Table 5-3. Line Power Checks

Step	Item/Component	Required Condition	Remarks
1	S101 Line Switch	Must be set to 105-125V or 210-250V as appropriate. **	
2	S102 LINE/BAT Switch	Must be set to BAT for use with battery pack.	
3	F102 Line Fuse	Continuity	
4	P1007 Line Cord	Plugged into live receptacle.	
5		Turn on power.	
6	+5V Pad*	+5V \pm 5%	Output of VR101.
7	VR101, IN C120-2200 μ F (+)	+7V minimum.	Output of CR103, input to VR101.
8	+15V Pad*	+15V \pm 10%	Output of VR102,
9	VR102 IN, C123-470 μ F (+)	+17.5V minimum.	Output of CR104, input to VR102.
10	-15V Pad*	-15V \pm 10%	Output of VR103.
11	VR103 IN, C125-470 μ F (-)	-17.5V minimum.	Output of CR104, input to VR103
			NOTE: Hot regulator may indicate shorted load.

*On main printed circuit board (see Figure 5-1).

**On optional line voltage units set to 90-110V or 180-220V as appropriate.

Table 5-4. Battery Power Checks

Step	Item/Component	Required Condition	Remarks
1		Check AC line power per Table 5-3.	
2		Turn off power.	
3	S102 LINE/BAT Switch	Move to BAT.	
4	P1007 Line Cord	Plugged into live receptacle.	
5	F301	Remove fuse and connect ammeter to fuse clip 0 to 500mA	Charge circuit checks.
5A	BT301 Batteries	charging rate, varies with line voltage and battery state of charge. Full charge is $\approx 9.8V$ over 4 cells. R301 adjusts charging rate (float voltage).	No charge, see step 5A. Correct charging but short battery operating time, see step 6. If voltage is low and adjustment of R301 does not start charging, see steps 7 and following. If voltage is low and adjustment of R301 does start charging, see Table 5-11 for adjustment of battery charge voltage.
6	Each battery cell voltage during charging.	1.5—3V for any cell.	High voltage or zero indicates damaged cell.
7	Q301 Anode	Full wave rectified voltage, 15 VDC nominal.	Output of CR103
8	C304 +	+ 17.5V minimum.	Output of CR104. Triggers Q301 gate thru R306 and CR301 unless Q302 is on.
9	Q302	Should saturate only when battery approaches full charge.	
10	VR301	8.2V zener.	
11		Unplug line cord & turn power on.	Discharge checks.
12	P1004 pin 8 or U301 pin 11.	100kHz 5V square wave.	Clock input. If no input, see step 12A.
12A	VR101, IN	+ 7V minimum	Battery voltage input to VR101.
13	Q307 and Q308 Base	Square wave, $\pm 0.7V$ at 25kHz.	Output of U301, + 4.
14	Q307, Q308 Collector	Must oscillate from saturation to twice battery voltage ($\approx 19V$) at 25kHz.	Inverter
15	C304, C305	$\pm 17.5V$ minimum ($\pm 25V$ typical with fully charged bat.)	Inverter Output, input to VR102 and VR103

Table 5-5. Display Checks

Step	Item/Component	Required Condition	Remarks
1		Turn on power. Any function or range, except OHMS.	
2	+5V Pad* or J1001, pin 7	+5V \pm 5%	If low, check per Table 5-3
3	U202, pins 2, 6, 7, 9 and 13	Digit drive. Low = Enabled	LED Cathode
4	U203, pins 1, 2, 6 and 7	HI = Enabled	BCD input to U203 segment decoder/drive
5	U203, pin 2	Negative-going signal lasting for 200 clock pulses.	Leading digit suppression.
6	J1001, pin 2	Polarity Line (sign) HI = Off LO = -	Polarity output is disabled on AC an Ω .
7	J1001, pin 4 J1002, pins 1, 11 & 12	Appropriate DP line high (on).	Depress RANGE push-buttons to check all DPs.

*On main printed circuit board. See Figure 5-1.

Table 5-6. A/D Converter Checks

Step	Item/Component	Required Condition	Remarks
1		Turn power on. Select 2VDC range.	
2	Display	.0000 \pm 1 digit	
3	TP1*	0.0000V	Input to U106, Chopper output.
4	TP2*	+1.00V	Reference output.
5		Short TP1 to TP2.	Connects reference output to U106 input.
6	Display	1.0000 \pm 2 digits	If steps 4 and 6 are correct A/D converter is functioning properly. If not, continue with step 7.
7	TP4*	0 to +5V square wave at 100kHz \pm 100Hz.	Clock input to U106.
8	TP3*	+1.0 \pm 0.1V	Stored autozero voltage.
9	U105, pin 11	+1.0 \pm 0.1V	Σ -node voltage to integrator in U105.
10	U105, pin 14	-1.2 \pm 0.2V	U105 integrator output voltage.
11	U105, pin 13	+1V	U105 buffer input.
12	U105, pin 9	+1V	U105 buffer output.
13	External Voltage Source.	Apply +1.9000V	Calibration point.
14	Display	1.9000 \pm 1 Digit	If different, check U106 input.
15	TP1	1.9000V	Input to U106.
16	U105, pin 14	Waveform per Figure 5-2.	Integrator output.
17	U105, pin 2	Waveform per Figure 5-2. during ramping in integrator.	Comparator output.

*On main printed circuit board, see Figure 5-1.

Table 5-7. AC Converter Checks

Step	Item/Component	Required Condition	Remarks
1		Turn on power. Select 2VAC range.	NOTE: Full scale input on all ranges should produce \approx 2V rms output at TP8*. Calibrated input.
2	External voltage source.	Apply 1V rms at 1kHz.	
3	TP10*	.99V rms nominal.	Output of U101 and feedback components R108 and C103 (nominal gain .99).
4	TP8*	.993V rms nominal.	Output of U102. (Q102 on, nominal gain 1.003).
5	U103 Pin 6 or TP1*	+ 1V	Output of U103. Gain of U103 adjusted to provide + 1VDC output for 1VAC ($\frac{1}{2}$ scale) input.
6	External voltage source.	Select 20VAC range. Apply 10V rms at 1kHz.	Gain check of U101 and U102. Nominally, .0099 (U101) and 10.03 (U102).
7	TP10	.099V rms nominal.	Output of U101 and feedback components R109, C104 and Q101 (on).
8	TP8	.993V rms nominal.	Output of U102 (Q102 off).
9	External voltage source.	Select 1000VAC range. Apply 10000V rms at 1kHz.	Calibrated input. Check gain of U101 (nominal .00099).
10	TP10	.99V rms nominal.	Output of U101 and feedback components K101, R110 and C105, K101 (Closed).
11	External voltage source.	Select 200VAC range. Apply 100V rms at 20kHz.	Calibrated input.
12	Display	100.00 nominal.	High frequency response (compensation C102, C103, C104).
13	External voltage source.	Select 2VAC range. Apply 1V rms at 20kHz.	Calibrated input.
14	Display	1.0000 nominal	High frequency response. (Compensation C102, C103).
15	External voltage source.	Select 1000VAC range. Apply 1000V rms at 20kHz.	
16	Display	1000.0 \pm nominal.	High frequency response. (Compensation C102, C103, C105).
17	External voltage source.	Select 2VAC range. Apply 1V rms at 45Hz.	
18	Display	1.0000V \pm nominal.	Low frequency response, C101, C106, C107, C108, C109.

*See Figure 5-1.

Table 5-8. DC Attenuation and Chopper Amplifier Checks

Step	Item/Component	Required Condition	Remarks
1		Turn on power. Select 20mVDC range. Short input and adjust F.P. Zero for $\pm .0000$ on display.	NOTE: Insufficient zero adjustment may indicate leaky FET switches in Chopper Amplifier Circuit. Chopper Drive. Signals are actually 0 to -15 square waves at 390Hz. A steady zero volt or -15V signal indicates a problem in the chopper drive or clock circuitry. Calibrated input.
2	TP5, TP6*	$\approx -7.5V$ DC (on DMM).	
3	External voltage source.	Apply +19mV.	Input to chopper amplifier +1 attenuation (range resistors). Input to U106, chopper output ($\times 100$ gain). Calibrated input.
4	R143 (yellow wire slide)*.	+19mV.	
5	TP1*	+1.9V	Input to chopper amplifier +1 attenuation. Input to U106, chopper output ($\times 10$ gain). Calibrated input.
6	External voltage source.	Select 200mVDC range. Apply +190mV.	
7	R143	+190mV	+1 attenuation, $\times 1$ chopper gain. Calibrated input.
8	TP1	+1.9V	
9	External voltage source.	Select 2VDC range. Apply +1.9V.	+10 attenuation (range resistors). Calibrated input.
10	R143, TP1	+1.9V	
11	External voltage source.	Select 20VDC range. Apply +19V.	+100 attenuation (range resistors). Calibrated input.
12	R143	+1.9V	
13	External voltage source.	Select 200VDC range. Apply +190V.	+1000 attenuation (range resistors). Calibrated input.
14	R143	+1.9V	
15	External voltage source.	Select 1000V (1200V) DC range. Apply +1000V.	
16	R143	+1V	

*On main printed circuit board, see Figure 5-1.

Table 5-9. Ohms Source and Resistor Checks

Step	Item/Component	Required Condition	Remarks
1		Check chopper amplifier operation per Table 5-7, steps 1 thru 10.	
2		Select 2kΩ range. Short input.	
3	Display	.0000 ± 1 digit.	
4	TP9*	-1V Approximately	Inverted reference voltage plus calibrated offset of U107.
5	INPUT HI to LO	Remove short and connect ammeter from INPUT HI to LO. Source current should be approximately 1mA, HI terminal negative.	If incorrect, check R158 and switching to INPUT HI and chopper amplifier.
6	INPUT HI to LO	Remove ammeter and measure open circuit voltage. Voltage must be -2 to -5V.	HI negative with respect to LO. Display should be blinking, indicating overrange.
7	1.9kΩ resistor.	Apply to INPUT.	Calibrated resistance.
8	Display	1.9000 ± 12 digits.	Subtract test lead resistance from reading. Checks accuracy of R158 and feedback loop to U107.
9	19kΩ resistor.	Apply to INPUT. Select 20kΩ range.	Calibrated resistance.
10	Display	19.000 ± 12 digits.	Source resistors: R158, R154 (8.975kΩ), R157 (wiper).
11	190kΩ resistor.	Apply to INPUT. Select 200kΩ range.	Calibrated resistance.
12	Display	190.00 ± 12 digits.	Source resistors: R158, R157 R156 (wiper), R154 (89.75kΩ), 8.975kΩ).
13	1900kΩ resistor.	Apply to INPUT. Select 2000kΩ range.	Calibrated resistance.
14	Display	1900.0 ± 12 digits.	Source resistors: R158, R157, R156, R155 (wiper), R154, (all except 8.975MΩ).
15	10MΩ resistor.	Apply to INPUT. Select 20MΩ range.	Calibrated resistance.
16	Display	10.000 ± 12 digits.	Source resistors: all Ω range resistors. NOTE: To conveniently measure the resistance of all Ω range resistors, turn power off, set all function switches out and measure resistance INPUT HI to LO.
		NOTE: Reference loading by the ohms source does not affect Ω readout since A/D converter is ratiometric.	

*See Figure 5-1.

Table 5-10. Current Shunt Checks

Step	Item/Component	Required Condition	Remarks
1	F101	Continuity	
2	R101, R102, R103, R104, R105	Correct shunt value for specified range. See schematic.	Apply a known ½ scale current and measure voltage across shunt.
3		Turn power on. Select DCA and 200μA range.	
4	External voltage source.	0 to 3V.	Clamping must occur at ±2V.

Table 5-11. Adjustment of Battery Charge Voltage

Step	Item/Component	Required Condition	Remarks
1		Instrument off.	
2	R301	Turn full CCW (maximum charge rate).	
3	BT301	Monitor battery voltage for > 9.8V.	Fully charged cells require several minutes to reach this level. Discharged cells require several hours.
4	R301	When cells reach 9.8V, turn DMM on and adjust to maintain 9.8V across BT301.	<p style="text-align: center;">CAUTION</p> <p>Charging to > 10V for longer than 30 minutes will reduce battery life.</p>

SECTION 6 REPLACEABLE PARTS

6.1 INTRODUCTION

This section contains information for ordering replacement parts.

6.2 PARTS LISTS

Table 6-2 contains a list of parts for the Model 177 mother board, Table 6-3 lists display board parts, and Table 6-4 lists parts for the optional Model 1788 Battery Pack. Each list is arranged in alphabetical order according to circuit designation. Mechanical parts are listed on Figure 6-1.

6.3 ORDERING INFORMATION

To place an order or to obtain information concerning replacement parts, contact your Keithley representative or the factory. See the inside front cover for addresses. When ordering, include the following information:

1. Instrument Model Number.
2. Instrument Serial Number.
3. Part Description.
4. Circuit Designation (if applicable).
5. Keithley Part Number.

6.4 FACTORY SERVICE

If the instrument is to be returned to the factory for service, please complete the service form which follows this section and return it with the instrument.

6.5 COMPONENT LOCATION DRAWINGS

1. Model 177 PC-476 Component Layout No. 29474D.
2. Display Board PC-475 Component Layout No. 29652C.
3. Model 1788 Battery Pack PC-451 Component Layout No. 29007C.

6.6 SCHEMATIC DIAGRAMS

1. Model 1788 Battery Pack: Schematic No. 29659C.
2. Model 177 4½ Digit Multimeter: Schematic No. 29658E.

6.7 MAINTENANCE KIT

A maintenance kit is available that contains a complement of spare parts that will maintain up to ten Model 177s. Specify Model 1779 Spare Parts Kit when ordering. A list of the kit parts is given in Table 6-1.

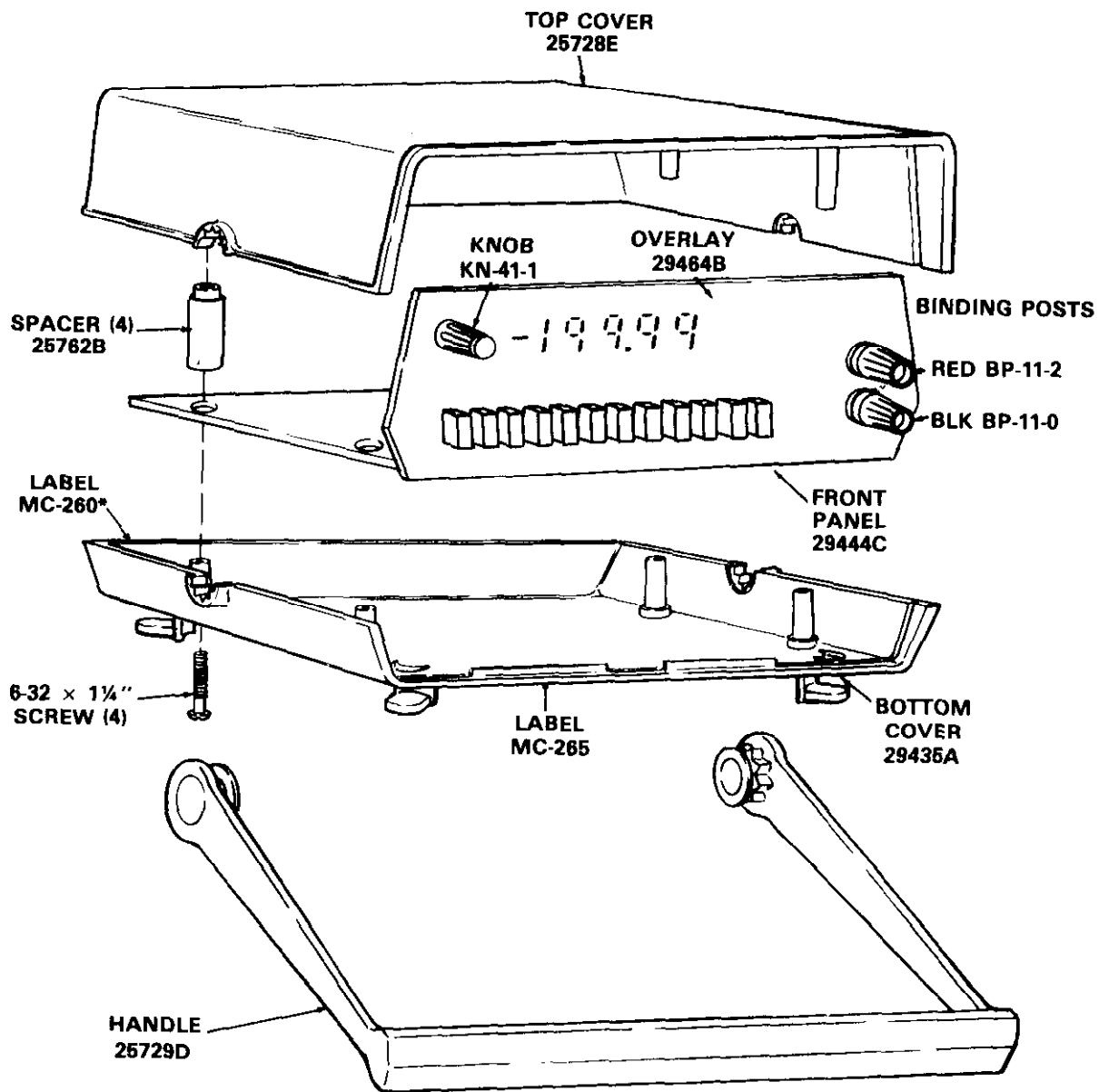

*ALTERNATE PART #MC-264 FOR OPTIONAL LINE VOLTAGE UNITS

Figure 6-1. Model 177 Covers and Panels

Table 6-1. Model 1779 Spare Parts Kit

Qty.	Keithley Part No.	Schematic Number	Description
2	DD-30	DS202, 3, 4,5	7-Segment Display
1	DD-31	DS201	± 1 Display
5	FU-13	F101	Line Fuse
2	FU-20	F102	Current Fuse
1	IC-93	VR101	+5V Regulator
1	IC-102*	U201	CMOS NAND Gate IC
1	IC-139*	U111	CMOS Hex Inverter IC
1	IC-168*	U203	Segment Driver IC
1	IC-169	U202	Digit Driver IC
1	IC-197*	U110	CMOS Binary Converter IC
1	IC-203	U107, 109	OP Amp IC
1	IC-205	U108	OP Amp IC
1	KN-41-1	Front Panel Zero	Knob
1	LSI-11	U106	Logic Processor IC
1	LSI-12	U105	Analog Processor IC
1	RL-56	K101	Relay
1	TF-80	R126	Thick Film Resistor
1	TG-77	Q101, 102, 105	2N4392 JFET
1	TG-93	Q103	2N3439 Transistor
1	TG-94*	Q104	Dual MOSFET

*Anti-Static Protection & Handling Required.

Table 6-2. Model 177 Mother Board, Parts List

Circuit Desig.	Description	Location		Keithley Part No.
		Sch	Pcb	
C101	Capacitor, 0.1 μ F, 1000V, Polyester Film	B3	E5	C-285-.1
C102	Capacitor, .25-1.5pF, 2000V, Teflon Trimmer	B3	C5	C-184
C103	Capacitor, .25-1.5pF, 2000V, Teflon Trimmer	D3	C5	C-184
C104	Capacitor, 110pF, 500VDC, \pm 1%, Silver Mica	D3	C5	C-278-110p
C105	Capacitor, 1100pF, 500VDC, \pm 5%, Mica	D3	C5	C-236-1100pF
C106	Capacitor, 33 μ F, 16VDC, \pm 10%, Aluminum Electrolytic	D4	C4	C-321-33
C107	Capacitor, 33 μ F, 16VDC, \pm 10%, Aluminum Electrolytic	D4	C4	C-321-33
C108	Capacitor, 1 μ F, 100V, \pm 10%, Polyester Film	E4	D4	C-294-1
C109	Capacitor, 1 μ F, 100V, \pm 10%, Polyester Film	E3	C4	C-294-1
C110	NOT USED			
C111	Capacitor, 2200pF, 500V, Ceramic Disc	G2	C2	C-22-2200pF
C112	Capacitor, 100pF, 1000V, Ceramic Disc	D5	C3	C-64-100p
C113	NOT USED			
C114	NOT USED			
C115	Capacitor, 1 μ F, 100V, \pm 10%, Polyester Film	H4	B1	C-294-1
C116	Capacitor, 4 μ F, 100V, 10%, Polyester Film	G3	B2	C-294-4
C117	Capacitor, .22 μ F, 200VDC, \pm 10%, Polyester Film	H3	B2	C-269-.22
C118	Capacitor, .12 μ F, 100V, 10%, Polyester Film	G4	C2	C-294-.12
C119	NOT USED			
C120	Capacitor, 2200 μ F, 15V, Aluminum Electrolytic	D7	B3	C-290-2200
C121	Capacitor, 4.7 μ F, 25V, Aluminum Electrolytic	E7	B5	C-314-4.7
C122	Capacitor, 4.7 μ F, 25V, Aluminum Electrolytic	E7	B5	C-314-4.7
C123	Capacitor, 470 μ F, 35V, Aluminum Electrolytic	D8	B4	C-289-470
C124	Capacitor, 4.7 μ F, 25V, Aluminum Electrolytic	C5	C3	C-314-4.7
C125	Capacitor, 470F, 35V, Aluminum Electrolytic	D8	B5	C-289-470
C126	Capacitor, 10 μ F, 25V, Aluminum Electrolytic	C5	C3	C-314-10
C127	NOT USED			
C128	NOT USED			
C129	NOT USED			
C130	Capacitor, 100pF, 1000V, Ceramic Disc	A6	B2	C-64-100p
C131	Capacitor, 100pF, 630V, 25%, Polystyrene Film	C7	C2	C-252-100p
C132	Capacitor, 100pF, 630V, 25%, Polystyrene Film	B7	A2	C-252-100p
C133	Capacitor, .0047 μ F, 100V, Polystyrene	B5	D3	C-301-.0047
C134	Capacitor, .12 μ F, 100V, 10%, Polyester Film	B4	D3	C-294-.12
C135	Capacitor, 1000pF, 500V, Polystyrene	C5	D3	C-138-1000p
C136	NOT USED			
C137	NOT USED			
C138	Capacitor, 1 μ F, 100V, 10%, Polyester Film	E5	C3	C-294-2
C139	Capacitor, 1 μ F, 100V, 10%, Polyester Film	C5	C3	C-294-1
C140	Capacitor, .047 μ F, 100V, Polystyrene	B5	D2	C-301-.047
CR101	Bridge Rectifier, 100V, 1.5A	B1	D3	RF-36
CR102	Silicon Rectifier, 3A, 50PIV, 1N4139	B1	D3	RF-34
CR103	Bridge Rectifier, 100V, 1.5A	D7	B5	RF-36
CR104	Bridge Rectifier, 400V, 1.5A	D8	—	RF-46
CR105	NOT USED			
CR106	Diode, Silicon, 1N4148	C3	C5	RF-28
CR107	Diode, Silicon, 1N4148	C3	C5	RF-28
CR108	NOT USED			
CR109	NOT USED			
CR110	Diode, Silicon, 1N4148	H2	A2	RF-28

Table 6-2. Model 177 Mother Board, Parts List (Cont.)

Circuit Desig.	Description	Location		Keithley Part No.
		Sch	Pcb	
CR111	Diode, Silicon, 1N4148	H3	A2	RF-28
CR112	Diode, Silicon, 1N4148	H4	B2	RF-28
CR113	Diode, Silicon, 1N4148	H4	B2	RF-28
CR114	Diode, Silicon, 1N4148	B6	D3	RF-28
CR115	NOT USED			
CR116	NOT USED			
CR117	Diode, Silicon, 1N4148	F3	—	RF-28
CR118	NOT USED			
CR119	NOT USED			
CR120	Rectifier, 1A, 800V, 1N4006	F1	B4	RF-38
F101	Fuse, 2A, 250V, 3AG, Quick	B1	D3	FU-13
F102	Fuse, Slo-Blo, 1/8A, 250V, 3AG (115V Version)	C8	B4	FU-20
F102	Fuse, Slo-Blo, 3/16A, 250V (100V Version)	C8	B4	FU-29
J1001	8-Pin Connector	F6	E5	CS-356-4
J1002	12-Pin Connector	G6	E2	CS-356-6
J1003	Female Connector	C8	—	CS-288-3
J1004	Connector Housing	A3	D5	CS-287-8
J1005	Binding Post, Black	—	—	BP-11-0
J1006	Binding Post, Red	—	—	BP-11-2
J1007	NOT USED			
J1008	14-Pin Connector	K5	E2	SO-70
J1009	Contact	F5	A1	29316A
K101	Relay, 5V, Reed Type	C3	C5	RL-56
P1001	8-Pin Connector	G6	A3	CS-355-4
P1002	12-Pin Connector	G6	F3	CS-355-6
P1003	Connector, Male	C8	A4	CS-288-3
P1004	Connector, Male	E6	A3	29467A
P1005	NOT USED			
P1006	NOT USED			
P1007	Line Cord	C8	—	CO-9
Q101	Transistor, N-Chan, JFET, 2N4392	C3	C5	TG-77
Q102	Transistor, N-Chan, JFET, 2N4392	D4	C4	TG-77
Q103	Transistor, NPN, Case TO-5, 2N3439	F1	C3	TG-93
Q104	Transistor, Dual "P" Channel MOSFET 8-Pin TO-77	C5	D3	TG-94
Q105	Transistor, N-Chan JFET, 2N4392	D5	C3	TG-77
Q106	Transistor, NPN, 2N5139	A7	B2	TG-66
Q107	Transistor, NPN, Silicon, 2N3565	G1	C2	TG-39
Q108	Transistor, N-Chan, JFET		D3	TG-139
R101	Resistor, .1 Ω , 7.5W, Wire Wound	B2	E2	R-262-.1
R102	Resistor, 0.898 Ω , 0.1%, Wire Wound			R-310-.898
R103	Resistor, 9 Ω , .1%, 5W, Wire Wound	B2	D2	R-252-9
R104	Resistor, 90 Ω , .1%, 1/2W, Metal Film	C2	D2	R-169-90
R105	Resistor, 900 Ω , .1%, 1/8W, Metal Film	C2	D2	R-168-900
R106	NOT USED			
R107	Resistor, 1.005M Ω , 0.5%, 2W, Metal Film			R-284-1.005M
R108	Resistor, 990k Ω , .1%, 1/8W, Metal Film	D3	C5	R-176-990k
R109	Resistor, 9.97k Ω , .1%M 1/8W, Metal Film	D3	C5	R-176-9.97k
R110	Resistor, 991 Ω , .1%, 1/8W, Metal Film	D3	C5	R-176-991
R111	Resistor, 90.3k Ω , .1%, 1/8W	D4	C4	R-176-90.3k
R112	Resistor, 10k Ω , .1%, 1/8W	C4	C4	R-176-10k
R113	Resistor, 500 Ω , 0.5W, Potentiometer	E4	D4	RP-97-500

Table 6-2. Model 177 Mother Board, Parts List (Cont.)

Circuit Desig.	Description	Location		Keithley Part No.
		Sch	Pcb	
R114	Resistor, 50k Ω , 10%, Cermet Trimmer	G2	D4	RP-97-50k
R115	NOT USED			
R116	NOT USED			
R117	Resistor, 27k Ω , 5%, 1/4W, Composition	A7	C2	R-76-27k
R118	Resistor, 4.32k Ω , 1%, 1/8W	B7	C3	R-88-4.32k
R119	Resistor, 4.99k Ω , 1%, 1/8W	B7	C2	R-88-4.99k
R120	NOT USED			
R121	Resistor, 3.9k Ω , 10%, 1/2W, Composition	F5	A1	R-1-3.9k
R122	Resistor, 1k Ω , 5%, 1/4W, Composition	F6	A1	R-76-1k
R123	NOT USED			
R124	NOT USED			
R125	Resistor, Thick Film	SEV	C3	TF-79
R126	Resistor, Thick Film	SEV	C3	TF-80
R127	NOT USED			
R128	Resistor, 27k Ω , 5%, 1/4W, Composition	G6	D5	R-76-27k
R129	NOT USED			
R130	Resistor, 6.49k Ω , 1%, 1/8W	J1	A3	R-88-6.49k
R131	Resistor, 3.65k Ω , 1%, 1/8W	J1	A3	R-88-3.65k
R132	Resistor, 806 Ω , 1%, 1/8W	H1	A3	R-88-806
R133	Resistor, 2.15k Ω , 0.1%, 1/10W Metal Film	H1	A3	R-263-2.15k
R134	Resistor, 50 Ω , 3/4W, POT	H1	A3	RP-64-50
R135	Resistor, 402 Ω , 0.1%, 1/10W	H2	A3	R-263-402
R136	Resistor, 100k Ω , 1%, 1/8W	H3	B2	R-88-100k
R137	Resistor, Selected with VR104	H1	A3	27699A
R138	Resistor, 33.2k Ω , \pm 1%, 1/8W	F5	C4	R-88-33.2k
R139	Resistor, 50k Ω , 5%, Cermet Trimmer	D1	D3	RP-97-50k
R140	Resistor, 47k Ω , 5%, 1/4W, Composition	A6	B3	R-76-47k
R141	Resistor, 22M, 10%, 1/4W	A6	B3	R-76-22M
R142	Resistor, 1k Ω , 10%, 3/4W, Potentiometer	B7	A3	RP-64-1k
R143	Resistor, 100k Ω , 10%, 2W, Composition	B5	D3	R-3-100k
R144	Resistor, 22k Ω , 5%, 1/4W, Composition	B5	D3	R-76-22k
R145	Resistor, 922 Ω , 0.1%, 1/4W, Metal Film	E5	C4	R-264-922
R146	Resistor, 10k Ω , 0.5W, Potentiometer	F5	C4	RP-97-10k
R147	Resistor, 100 Ω , 0.5W, Potentiometer	E5	C4	RP-97-100
R148	Resistor, 8.95k Ω , 0.1%, 1/10W, Metal Film	F5	C4	R-263-8.95k
R149	Resistor, 100 Ω , .1%, 1/10W, Metal Film	F6	C4	R-263-100
R150	Resistor, 998k Ω , .1%, 1/4W, Metal Film	G1	D2	R-264-998k
R151	Resistor, 998k Ω , .1%, 1/4W, Metal Film	G1	D2	R-264-998k
R152	Resistor, 998k Ω , .1%, 1/4W, Metal Film	G1	D2	R-264-998k
R153	Resistor, 994k Ω , .1%, 1/4W, Metal Film	G2	D2	R-264-994k
R154	Resistor, Thick Film	D1	D3	TF-78
R155	Resistor, 5k Ω , 10%, Cermet Trimmer	D1	D4	RP-97-5k
R156	Resistor, 500 Ω , 10%, Cermet Trimmer	E1	D3	RP-97-500
R157	Resistor, 50 Ω , 10%, Cermet Trimmer	E1	D4	RP-97-50
R158	Resistor, 1k Ω , 0.1%, 1/10W			R-263-1.000k
R159	Resistor, 10k Ω , 10%, Cermet Trimmer	G2	D2	RP-89-10k
R160	NOT USED			
R161	Resistor, 4.3M Ω , 1/4W, Composition			R-76-4.3M
R162	Resistor, 50k Ω , 10%, Cermet Trimmer	G2	C2	RP-89-50k
R163	Resistor, 200k Ω , .5W, Potentiometer	E5	C4	RP-97-200k
R164	Resistor, 200k Ω , 1%, 1/8W	G2	D2	R-88-200k
R165	Resistor, 100 Ω , 1%, 1/8W	G2	C2	R-88-100

Table 6-2. Model 177 Mother Board, Parts List (Cont.)

Circuit Desig.	Description	Location		Keithley Part No.
		Sch	Pcb	
R166	Resistor, 80.6k Ω , 1%, 1/8W	—	—	R-88-80.6k
R167	Resistor, 100k Ω , 1%, 1/8W	—	—	R-88-100k
S101	Switch, Line Selector	C7	A4	SW-318
S102	Switch, Line Battery	D7	B4	SW-397
S103	Switch, 12 Station Pushbutton	SEV	E3	29434B
T101	Transformer, Power (115, 230V)	D6	A5	TR-168
T101	Transformer, Power (100, 200V)	D6	A5	TR-169
U101	IC, 8-Pin Op-Amp JFET, TL081	C4	C5	IC-196
U102	IC, BI-FET, Op-Amp, LF351	D4	C4	IC-176
U103	IC, True RMS-TO-DC Converter, AD536 (TO-100)	E4	D5	IC-172-1
U104	IC, 8-Pin Op-Amp, 741	J1	A2	IC-42
U105	IC, 4 1/2 Digit Analog-Processor, 8052	H3	A2	LSI-12
U106	IC, 4 1/2 Digit Logic-Processor, 7103	H4	C2	LSI-11
U107	IC, Linear Op-Amp 8-Pin, LM308	G1	C2	IC-203
U108	IC, J-FET Input Op-Amp, LF355 (selected)	C5	C3	IC-205
U109	IC, Linear Op-Amp 8-Pin, LM308	D5	C3	IC-203
U110	IC, CMOS 14-Stage Binary Converter, 4060	A6	B2	IC-197
U111	CMOS/MOS Hex Converter, 4069	A7	C2	IC-139
VR101	Regulator, +5V, 3-Term, TO-220, 7805	E7	B5	IC-93
VR102	Regulator, +15V, 500mA, 78M15	E8	B5	IC-194
VR103	Regulator, -15V, 500mA, 79M15	E8	B5	IC-195
VR104	Regulator, Diode, Selected with R137			27699A
Y101	Crystal, Quartz $\pm 0.01\%$, 100kHz	A6	B3	CR-8

Table 6-3. Model 1788 Battery Pack, Parts List

Circuit Desig.	Description	Location		Keithley Part No.
		Sch	Pcb	
BT301	D Cells for BT301 (4 required)	E2		BA-33
C301	Capacitor, 4.7 μ F, 20V	D3	E3	C-179-4.7
C302	Capacitor, 4.7 μ F, 20V	D4	E3	C-179-4.7
C303	Capacitor, 1.0 μ F, 250V	E4	E3	C-256-1
C304	Capacitor, 100 μ F, 35V	B5	F4	C-295-100
C305	Capacitor, 100 μ F, 35V	B5	F3	C-295-100
CR301	Diode, Silicon, 1N4148	B3	D4	RF-28
CR302	Diode, Silicon, 1N4148	D4	E3	RF-28
CR303	Diode, Silicon, 1N4148	D4	E3	RF-28
CR304	Diode, Silicon, 1N4148	C5	F4	RF-28
CR305	Diode, Silicon, 1N4148	C5	F4	RF-28
F301	Fuse, 2A, 250V, 3AG, Quick blow	E1	C3	FU-13
Q301	Thyristor, SCR, 106F1	B2	C4	TG-132
Q302	Transistor, NPN, 2N3904	B3	C3	TG-47
Q303	Transistor, PNP, Silicon, TO-92 Case, 2N3905	D3	D4	TG-53
Q304	Transistor, NPN, 2N3904	D3	E4	TG-47
Q305	Transistor, NPN, 2N3904	C4	E4	TG-47
Q306	Transistor, PNP, Silicon, 2N3905	C4	E4	TG-53
Q307	Transistor, NPN, 2N3725	D3	E3	TG-131
Q308	Transistor, NPN, 2N3725	D4	E3	TG-131
Q309	Transistor, PNP, Silicon, MPS-U95	C2	D3	TG-133
Q310	Transistor, PNP, Silicon, TO-92 Case, 2N3905	C2	D3	TG-53
R301	Resistor, 20k Ω , 10%, Cermet Trimmer	C3	C3	RP-97-20k
R302	Resistor, 330 Ω , 10%, 1/4W, Composition	B3	C3	R-76-330
R303	Resistor, 1k Ω , 10%, 1/4W, Composition	B3	D4	R-76-1k
R304	Resistor, 3.9k Ω , 20%, 3W, Wire Wound	B2	D4	R-268-3.9k
R305	Resistor, 4.7k Ω , 10%, 1/4W, Composition	B4	D3	R-76-4.7k
R306	Resistor, 3.3k Ω , 10%, 1/4W, Composition	B4	C3	R-76-3.3k
R307	Resistor, 82 Ω , 10%, 1/4W, Composition	D4	E3	R-76-82
R308	Resistor, 82 Ω , 10%, 1/4W, Composition	D4	E3	R-76-82
R309	Resistor, 10 Ω , 10%, 1/4W, Composition	B5	F4	R-76-10
R310	Resistor, 10 Ω , 10%, 1/4W, Composition	B5	F4	R-76-10
R311	Resistor, 100k Ω , 1%, 1/8W, Composition	D2	E3	R-76-100k
R312	Resistor, 100k Ω , 1%, 1/8W, Composition	D2	E3	R-76-100k
R313	Resistor, 100k Ω , 1%, 1/8W, Composition	D2	E3	R-76-100k
R314	Resistor, 6.8M Ω , 10%, 1/4W, Composition	D2	E3	R-76-6.8M
R315	Resistor, 576k Ω , 1%, 1/8W	D2	E3	R-88-576k
R316	Resistor, 100k Ω , 1%, 1/8W	D2	E3	R-88-100k
U301	IC, Dual D-Type Flip-Flop, 4013	C4	D3	IC-103
U302	IC, 1.1V Micro-Power Detector, ICL8211	D2	E3	IC-177
VR301	Regulator, 8.2V, Zener, 1N765A	B3	C3	DZ-61

Table 6-4. Display Board, Parts List

Circuit Desig.	Description	Location		Keithley Part No.
		Sch	Pcb	
C201	Capacitor,			C-314-4.7
DS201	LED, Display, ± 1			DD-31
DS202	LED, Display, 7-Segment			DD-30
DS203	LED, Display, 7-Segment			DD-30
DS204	LED, Dsisplay, 7-Segment			DD-30
DS205	LED, Display, 7-Segment			DD-30
R201	Resistor, Thick Film	G8	C3	TF-82
R202	Resistor, Thick Film			TF-102-3
R203	Resistor, Potentiometer, 2W	G6	A2	RP-117-50k
U201	IC, CMOS, Quad 2-Input NAND Gate, 4011	SEV	E3	IC-102
U202	IC, Digit Driver, 75492	G7	E2	IC-169
U203	IC, Segment Driver, 4511	J7	E3	IC-168

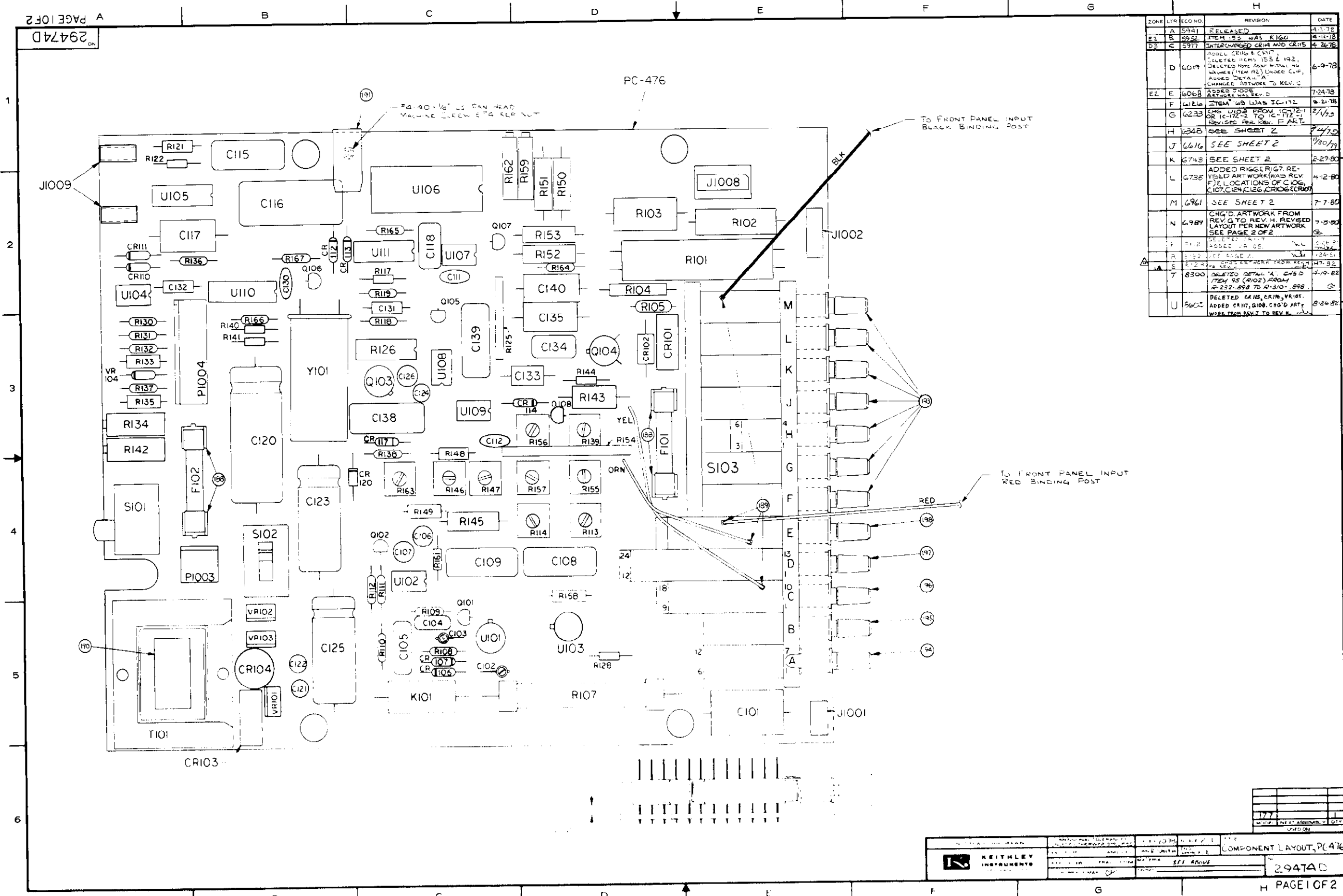

ZONE	LTR	RECORD	REVISION	DATE
A	5941		RELEASED	4-3-78
B	5952		ITEM 183 WAS R160	4-12-78
C	5977		INTERCHANGED CR14 AND CR15	4-26-78
D	6019		ADDED CR16 & CR17 DELETED ITEMS 155 & 192, DELETED NOTE ASS'N WITH ALL NUMBERS (ITEM #2) UNDER CLIP, ADDED DETAIL "A" CHANGED ARTWORK TO REV. C CHANGED ARTWORK TO REV. D	6-9-78
E	6068		ADDED FOOTER ARTWORK WAS REV. D	7-24-78
F	6126		ITEM 169 WAS IC-112	9-21-78
G	6233		CHG U108 FROM IC-112-1 OR IC-112-2 TO IC-112-1 REVISED PER REV. E ART.	2/1/79
H	6248		SEE SHEET 2	7/1/79
J	6616		SEE SHEET 2	1/30/79
K	6743		SEE SHEET 2	2-29-80
L	6735		ADDED RIGGER RIG7, REVISED ARTWORK (WAS REV. F), LOCATIONS OF C106, C107, C124, C126, CR106, CR107	4-12-80
M	6961		SEE SHEET 2	7-7-80
N	6989		CHG'D ARTWORK FROM REV. G TO REV. H, REVISED LAYOUT PER NEW ARTWORK SEE PAGE 2 OF 2	7-8-80
P	7112		ADDED CR 120	10-26-80
R	7122		SEE SHEET 2	12-4-81
S	7120		SEE SHEET 2	1-17-82
T	8300		DELETED DETAIL "A", CHG'D ITEM 95 (C102) FROM R-232-898 TO R-310-898	4-19-82
U	8602		DELETED CR15, CR16, VARIAS. ADDED CR17, Q108, CHG'D ART WORK FROM REV. T TO REV. U	8-24-82

KEITHLEY INSTRUMENTS
COMPONENT LAYOUT, PL 476
2947AD
PAGE 1 OF 2

ITEM	PART NO	SCHEM DESIG	ZONE	ITEM	PART NO	SCHEM DESIG	ZONE	ITEM	PART NO	SCHEM DESIG	ZONE	ITEM	PART NO	SCHEM DESIG	ZONE
1	294400	PC-476	D1	51	RF-28	CR106	CS	101	R-176-990K	R108	CS	151	R-263-1.0K	R158	DA
2				52	"	CR107	CS	102	R-176-9.97K	R109	CS	152	RP-89-10K	R159	D2
3				53				103	R-176-991	R110	CS	153			
4	C-285-1	C101	ES	54				104	R-176-90.3K	R111	CA	154	R-76-3.9M	R161	CA
5	C-184	C102	CS	55	RF-28	CR110	A2	105	R-176-10K	R112	CA	155	RP-89-50K	R162	C2
6	"	C103	CS	56	"	CR111	A2	106	RP-97-500	R113	DA	156	RP-97-200K	R163	CA
7	C-278-110pF	C104	CS	57	"	CR112	B2	107	RP-97-50K	R114	DA	157	R-88-200K	R164	D2
8	C-236-1100pF	C105	CS	58	"	CR113	B2	108				158	R-88-100	R165	C2
9	C-321-33	C106	CA	59	"	CR114	D3	109				159	R-88-80.6K	R166	B3
10	"	C107	CA	60				110	R-76-27K	R117	C2	160	R-88-100K	R167	B2
11	C-294-1	C108	DA	61				111	R-88-4.32K	R118	C3	161	SW-318	S101	A4
12	"	C109	CA	62	RF-28	CR117	C3	112	R-88-4.99K	R119	C2	162	SW-397	S102	BA
13				63				113				163	294248	S103	ES SW407
14	C-22-2200pF	C111	C2	64				114	R-1-3.9K	R121	A1	164			
15	C-64-100pF	C112	C3	65	RF-38	CR120	BA	115	R-76-1K	R122	A1	165	TR-168	T101	AS
16				66				116				166			
17				67				117				167	IC-196	U101	CS
18	C-294-1	C115	B1	68	FU-13	F101	D3	118	TF-79	R125	C3	168	IC-176	U102	CA
19	C-294-4	C116	B2	69	FU-20	F102	BA	119	TF-80	R126	C3	169	IC-172-1	U103	DE
20	C-269-.22	C117	B2	70				120				170	IC-42	U104	A2
21	C-294-.12	C118	C2	71	CS-356-4	J1001	ES	121	R-76-27K	R128	DS	171	LSI-12	U105	A2
22				72	CS-356-6	J1002	E2	122				172	LSI-11	U106	C2
23	C-290-2200	C120	B3	73	CS-288-3	F1003	A4	123	R-88-699K	R130	A3	173	IC-203	U107	C2
24	C-314-4.7	C121	B5	74	29467A	P1004	A3	124	R-88-3.65K	R131	A3	174	30967A	U108	C3
25	"	C122	B5	75				125	R-88-806	R132	A3	175	IC-203	U109	C3
26	C-289-470	C123	BA	76				126	R-263-2.15K	R133	A3	176	IC-197	U110	B2
27	C-314-4.7	C124	C3	77				127	RP-64-50	R134	A3	177	IC-139	U111	C2
28	C-289-470	C125	B5	78	SO-70	J100B	E2	128	R-263-402	R135	A3	178			
29	C-314-10	C126	C3	79	29316A	J1009	A1, A2	129	R-88-100K	R136	B2	179			
30				80				130	27699A	R137	A3	180	IC-93	VR101	B5
31				81				131	R-88-33.2K	R138	CA	181	IC-194	VR102	B5
32				82	RL-56	K101	CS	132	RP-97-50K	R139	D3	182	IC-194	VR103	B5
33	C-64-100pF	C130	B2	83				133	R-76-47K	R140	B3	183	27699A	VR104	A3
34	C-252-100pF	C131	C2	84				134	R-76-22M	R141	B3	184			
35	"	C132	A2	85	TG-77	Q101	CS	135	RP-64-1K	R142	A3	185			
36	C-301-.0047	C133	D3	86	"	Q102	A	136	R-3-100K	R143	D3	186	CR-B	VI01	B3
37	C-294-.12	C134	D3	87	TG-93	Q103	C3	137	R-76-22K	R144	D3	187			
38	C-138-1000pF	C135	D3	88	TG-94	Q104	D3	138	R-264-922	R145	CA	188	FH-12	4U	844D3
39				89	TG-77	Q105	C3	139	RP-97-OK	R146	CA	189	LU-90	4U	13,5EA
40				90	TG-66	Q106	B2	140	RP-97-100	R147	CA	190	MC-221		AS
41	C-294-2	C138	C3	91	TG-39	Q107	C2	141	R-263-895K	R148	CA	191	28776A		C1
42	C-294-15K	C139	C3	92	TG-139	Q108	D3	142	R-263-100	R149	CA	192			
43	C-301-.0047	C140	D2	93				143	R-264-998K	R150	D2	193	29465C-2	U103E	M F3
44				94	R-262-1	R101	E2	144	"	R151	D2	194	29465C-3	U103A	F5
45				95	R-310-898	R102	E2	145	"	R152	D2	195	29465C-4	U103B	F5
46	RF-36	CR101	D3	96	R-252-9	R103	D2	146	R-264-994K	R153	D2	196	29465C-5	U103C	F4
47	RF-34	CR102	D3	97	R-169-90	R104	D2	147	TF-78	R154	D3	197	29465C-6	U103D	F4
48	RF-36	CR103	B5	98	R-168-900	R105	D2	148	RP-97-5K	R155	DA	198	29465C-7	U103E	F4
49	RF-46	CR104	B5	99				149	RP-97-500	R156	C3	199			
50				100	R-264-1005M	R107	CS	150	RP-97-50	R157	DA	200			

ZONE	LTR	ECO NO	REVISION	DATE
A	5941		RELEASED	4-3-78
B	5952		REVISION 1	4-12-78
C	5917		REVISION 1	4-24-78
D	6019		ADDED ITEM 78, SO-70 DESIGN	6-9-78
E	6062		ADDED ITEM 78, SO-70 DESIGN	7-24-78
F	6126		ITEM FIG. 9 WAS IN 172	8-2-78
G	6233		SEE SHEET 1	8-12-78
H	6348		ITEM #29 WAS C-108-1000P	9-21-78
J	6616		ITEM #29 WAS C-175-4.7	1-6-79
K	6743		CHANGED ITEM B FROM C-278-100P TO C-236-1100P	2-27-80
L	6735		ADDED ITEMS 159 & 160	4-12-80
M	6961		CHANGED ITEM 74 FROM IC-205 TO 30967A	7-7-80
N	6989		CHGD. ITEMS 98, 101, 102, 103, 104, 105, 106, 107, 108, 109, 110, 111, 112, 113, 114, 115, 116, 117, 118, 119, 120, 121, 122, 123, 124, 125, 126, 127, 128, 129, 130, 131, 132, 133, 134, 135, 136, 137, 138, 139, 140, 141, 142, 143, 144, 145, 146, 147, 148, 149, 150, 151, 152, 153, 154, 155, 156, 157, 158, 159, 160, 161, 162, 163, 164, 165, 166, 167, 168, 169, 170, 171, 172, 173, 174, 175, 176, 177, 178, 179, 180, 181, 182, 183, 184, 185, 186, 187, 188, 189, 190, 191, 192, 193, 194, 195, 196, 197, 198, 199, 200	9-8-80
P	8112		SELECTED ITEM #84, DE-36, 1/2 P. DESIGNED	10-16-81
R	8332		ITEM #32 WAS SH-11-2 OR 3	11-24-81
S	8328		SEE PAGE 1	11-17-82
T	8300		SEE PAGE 1	11-17-82
U	8603		SEE PAGE 1	1-8-82

NOTE:
 1. FOR JAPANESE VERSION INSTITUTE
 2. FOR ITEM 94, FU-20 AND
 3. FOR ITEM 65, TR-168.

KEITHLEY INSTRUMENTS
 COMPONENT LAYOUT, PC-476
 29474D

Figure 6-2. Model 177 PC-476, Component Location Drawing. Dwg. No. 29474D (Sheet 2 of 2)

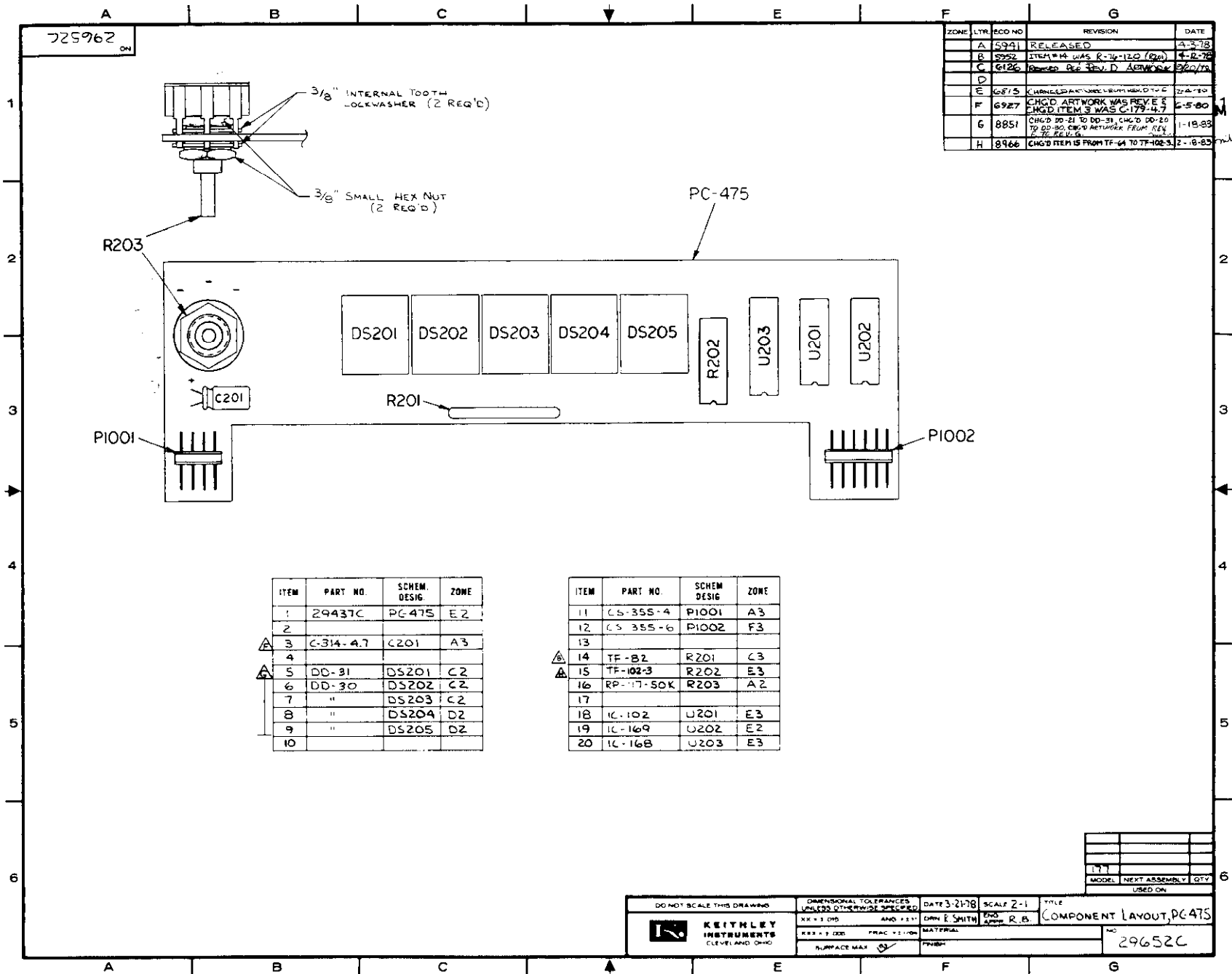

Figure 6-3. Display Board PC-475, Component Location Drawing, Dwg. No. 29652C

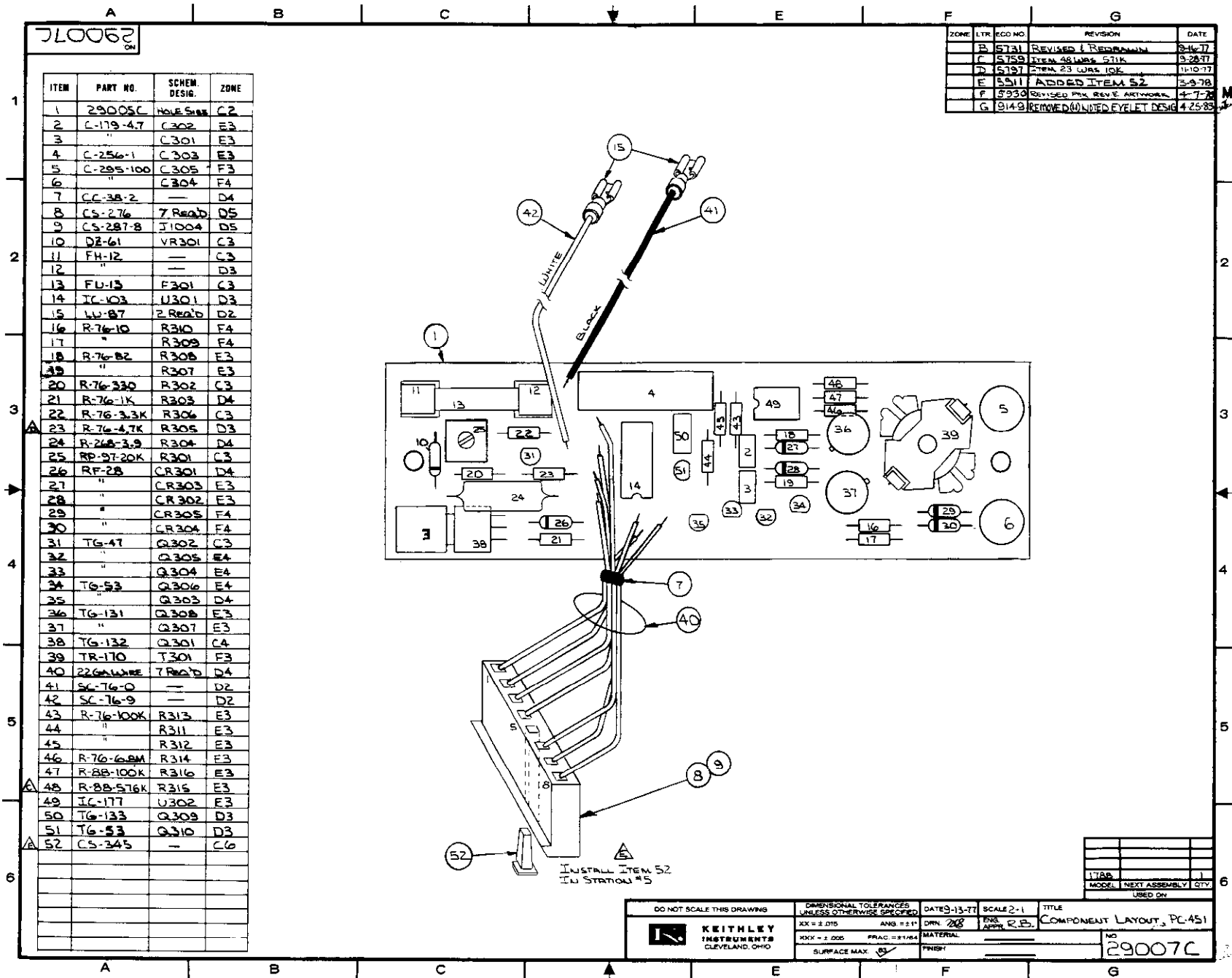
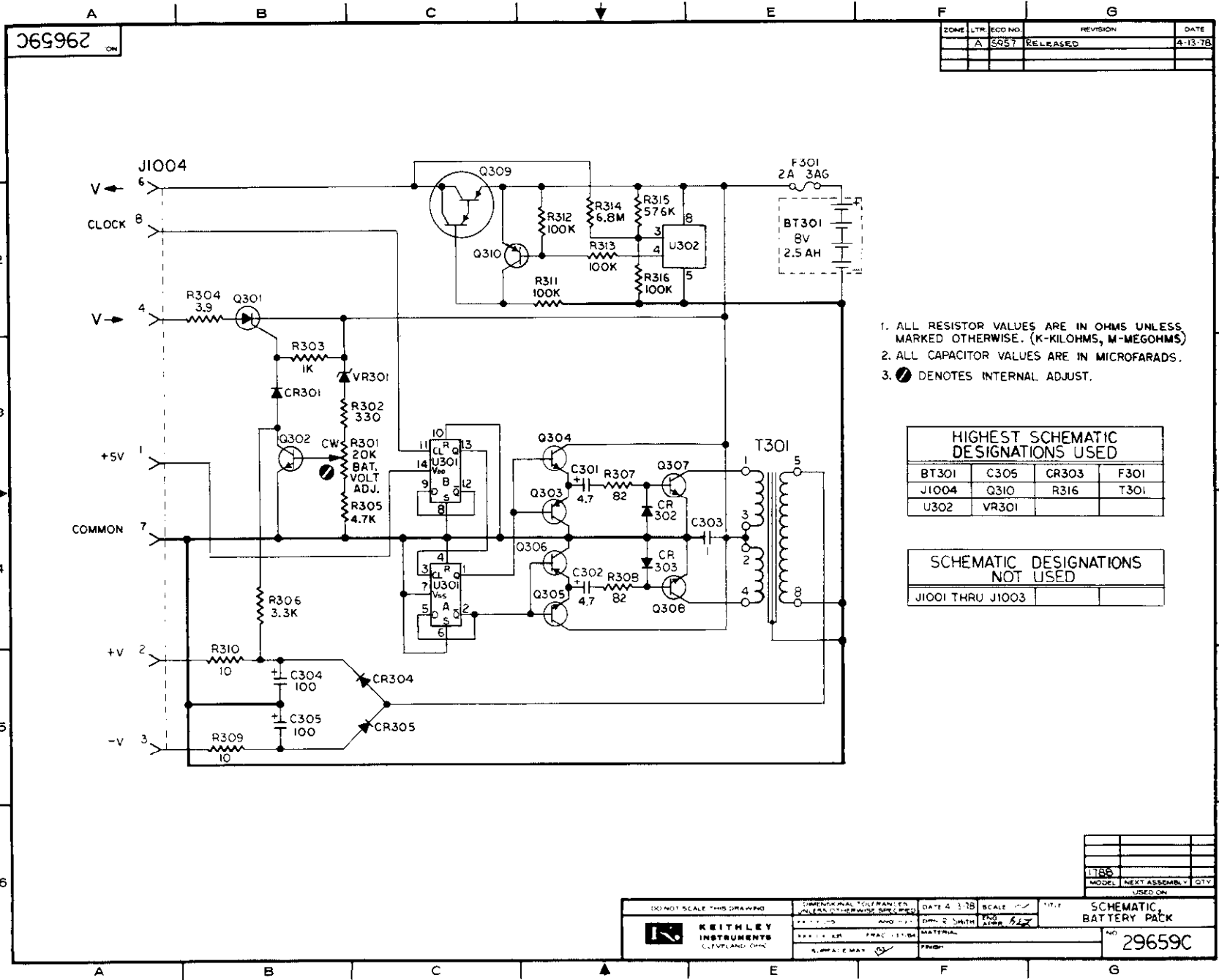

Figure 6-4. Model 1778 Battery Pack PC-451 Component Location Drawing, Dwg. No. 29007C



29659C

ZONE	LTR	ECO NO.	REVISION	DATE
A		5957	RELEASED	4-13-78

1. ALL RESISTOR VALUES ARE IN OHMS UNLESS MARKED OTHERWISE. (K-KILOHMS, M-MEGOHMS)
2. ALL CAPACITOR VALUES ARE IN MICROFARADS.
3. Ⓢ DENOTES INTERNAL ADJUST.

HIGHEST SCHEMATIC DESIGNATIONS USED			
BT301	C305	CR303	F301
J1004	Q310	R316	T301
U302	VR301		

SCHEMATIC DESIGNATIONS NOT USED	
J1001 THRU J1003	

DO NOT SCALE THIS DRAWING	DIFFERENTIAL TOLERANCES UNLESS INDICATED OTHERWISE	DATE 4-3-78	SCALE 1/8" = 1"	TITLE	SCHEMATIC, BATTERY PACK
	KEITHLEY INSTRUMENTS CLEVELAND, OHIO	DESIGNED BY	DRAWN BY	APPROVED BY	NO. 29659C
MATERIAL					USED ON

Figure 6-5. Model 1788 Battery Pack, Schematic Diagram, Dwg. No. 29659C

6-17/6-18

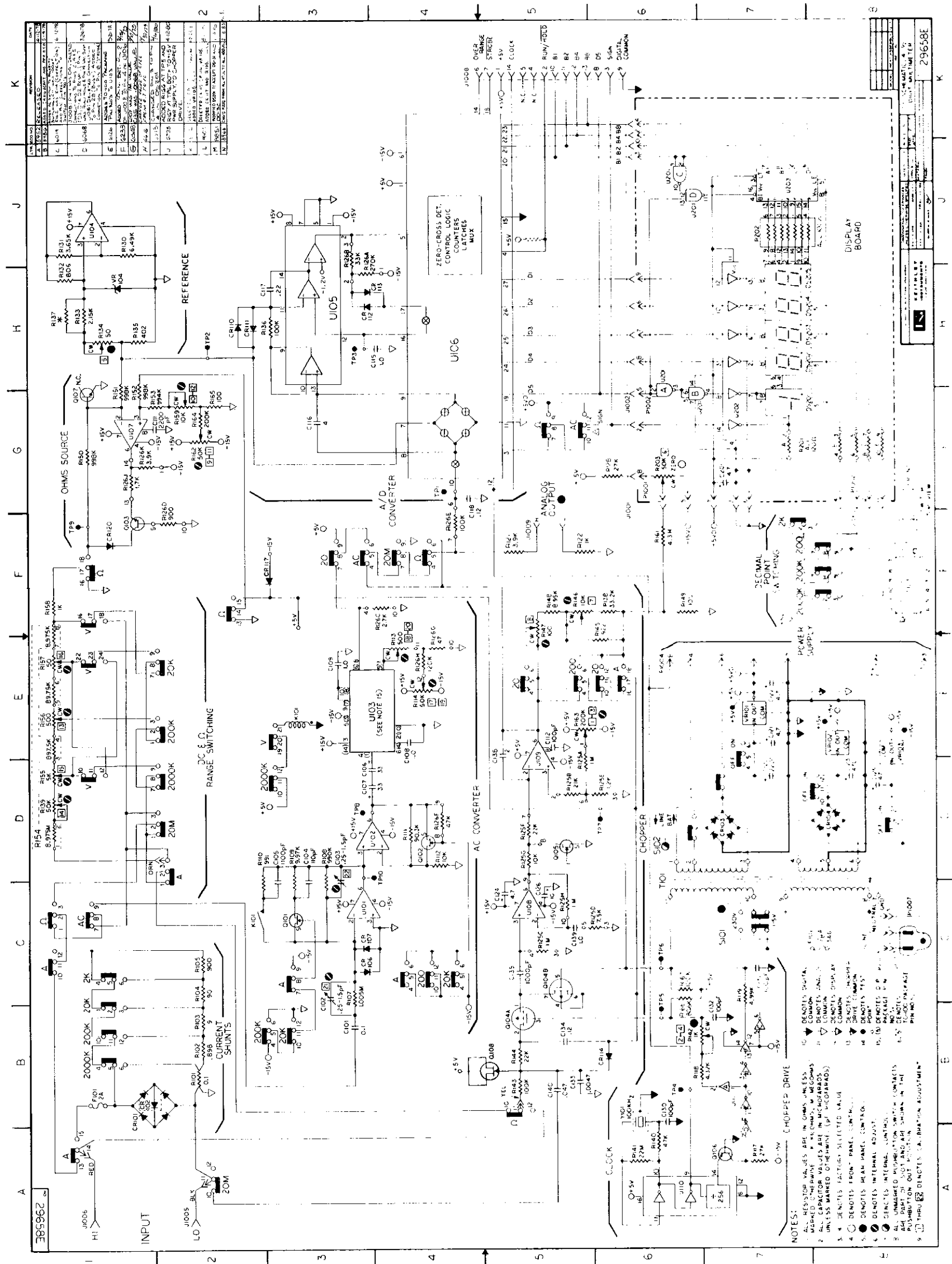

Figure 6-6. Model 177 4 1/2 Digit Multimeter, Schematic Diagram, Dwg. No. 29658E



SERVICE FORM

Model No. _____ Serial No. _____ P.O. No. _____ Date _____

Name _____ Phone _____

Company _____

Address _____

City _____ State _____ Zip _____

List all control settings and describe problem. _____

_____ (Attach additional sheets as necessary.)

Show a block diagram of your measurement system including all instruments connected (whether power is turned on or not). Also describe signal source.

Where is the measurement being performed? (factory, controlled laboratory, out-of-doors, etc.) _____

What power line voltage is used? _____ Variation? _____

Frequency? _____ Ambient Temperature? _____ °F.

Variation? _____ °F. Rel. Humidity? _____ Other? _____

Any additional information. (If special modifications have been made by the user, please describe below.)

*Be sure to include your name and phone number on this service form.