

MODEL 510
MEGOHMMETER
AND ACCESSORIES

KEITHLEY INSTRUMENTS, INC.
CLEVELAND, OHIO

CONTENTS

	SECTION
INTRODUCTORY.....	I
SPECIFICATIONS AND DESCRIPTION.....	II
OPERATION.....	III
MAINTENANCE.....	IV
General	
Circuit schematic	
Voltage and resistance diagram	
Replaceable parts list	
APPENDIX	
Accessories.....	i
Model 51036 Test Leads	
Model 5101 Component Adapter	
Model 5102 Volume Resistivity Adapter	
Models 51024 and 51060 Cables	
Measuring technique.....	ii
Introduction	
Speed of indication	
Component measurements	
Volume resistivity	
Special shielded enclosures	
Use of other than standard test potentials	
ASTM Reprint.....	Rear Cover

SECTION I INTRODUCTION

The Keithley Model 510 Megohmmeter utilizes a unique logarithmic circuit to present six decades of resistance on a six-inch mirror-scale panel meter. With so great a dynamic range, range switching is not necessary, and the speed and ease of measurement are greatly increased.

Because of the logarithmic scale, the usual high-end scale compression of a conventional ohmmeter is eliminated. An accuracy within 1% of the scale length is maintained at every point on the scale; this is equivalent to an accuracy of about 10% of the resistance being measured. It is limited only by the meter accuracy, and is about as good as conventional megohmmeter circuits at mid-scale, but superior to conventional circuits at other than mid-scale meter readings.

Test potentials of 5, 50 and 500 volts are furnished. They are useful in measuring voltage coefficients, and offer freedom in selecting a safe potential for all test samples.

SECTION II

MODEL 510 SPECIFICATIONS

Range and Test Potentials:

<u>Test Potential.</u>	<u>Resistance Span</u>
5 volts	10^7 to 10^{13} ohms
50 volts	10^8 to 10^{14} ohms
500 volts	10^9 to 10^{15} ohms

ACCURACY: within 1% of scale length, uniform over the entire scale. After a 15-minute warmup, calibration drift is negligible over an eight-hour period.

REGULATED TEST VOLTAGES: Regulation within 0.01% for line voltage changes from 100 to 130 volts.

OPERATING CONTROLS are the Test Potential-Calibrate Switch and a three-position lever switch, Test-Charge-Discharge. The lever switch allows discharge of capacitors, quick charge, and pre-electrification when desired.

PROTECTIVE FEATURES: All test potentials are removed when the operating switch is in the discharge position. Similarly, a switch is included in the test fixtures (Models 5101 and 5102) that automatically grounds all electrodes when the cover is raised. The instrument cannot be damaged by short circuits.

ACCESSORIES SUPPLIED: Model 51036 Test Leads, 36 inches long, separate Hi and ground leads terminated in alligator clips. The leads are useful for tests up to about 10^{12} ohms with a 5-volt potential, 10^{13} ohms with 50 volts, or 10^{14} ohms with 500 volts. For higher readings, the 5101 or 5102 adapters should be used.

ACCESSORIES AVAILABLE: Models 5101 and 5102 Test Adapters; Models 51024 and 51060 Cables.

CABINET is aluminum, $6\frac{5}{8}$ " x $10\frac{1}{4}$ " high x $12\frac{1}{2}$ " deep. Net weight, $16\frac{1}{2}$ pounds.

CIRCUIT DESCRIPTION

The Model 510 Megohmmeter consists of a regulated voltage supply which provides 5, 50 and 500 volt test potentials, and a logarithmic micro-microammeter which meters the sample current. The panel meter reads ohms directly.

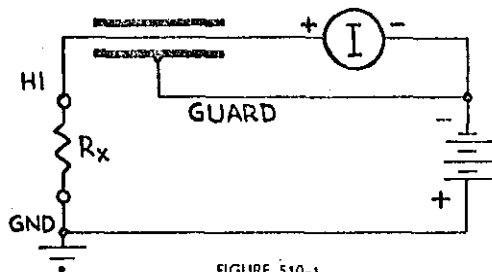

FIGURE 510-1

Figure 510-1 shows a simplified diagram of a resistance measurement using the 510. The positive terminal of the test potential is grounded and the negative terminal is applied to the unknown specimen through the micro-microammeter. The voltage drop across the input of the micro-microammeter is small compared to the test potential. Using the negative terminal of the voltage supply as a shield around all high impedance input leads to the micro-microammeter assures negligible error due to leakage across the input terminal insulation. The method is called guarding and the negative terminal of the supply is referred to as the guard potential.

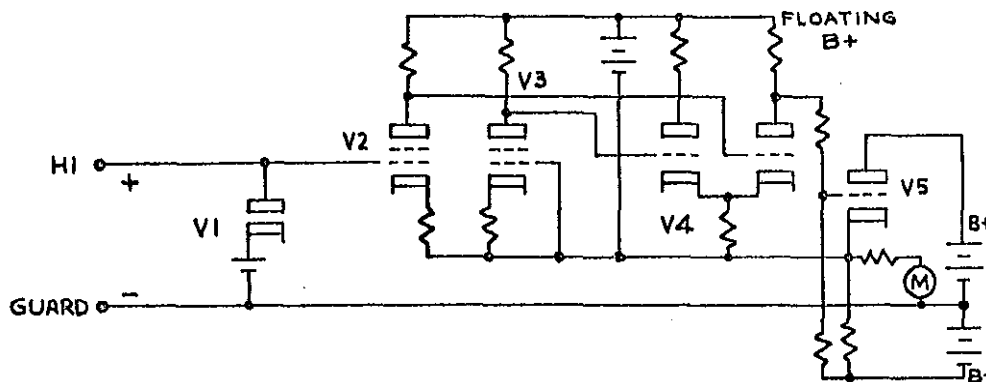

FIGURE 510-2

Figure 510-2 is a simplified diagram of the micro-microammeter used in the Model 510.

The following circuit description refers to DR 11504-C in MAINTENANCE, Section IV.

The power supply comprises a Sola regulating transformer, a rectifier-filter system and a two-stage electronic regulator. Selenium rectifiers SR5 through SR9 provide a half wave rectified output which is filtered by R401, C402 and C403. R402 and R403 are used to equalize the voltage across the series capacitors.

Following the filter is an electronic regulator employing V6 as a series tube and V7 and V9 as a two stage amplifier. V9 acts as the error detector. The output of the 500 volt supply, divided down by R415, R411, and R410, is compared to voltage reference tube V8. R411 is used to set the test potential at 500 volts. 50 and 5 volt test potentials are obtained from the divider consisting of R415, R414, R413 and R412.

The micro-microammeter consists of shunt diode, V1, and an electrometer amplifier which measures the potential across diode V1. This potential is proportional to the logarithm of the current through the diode. The grid and filament of V1 act as the diode. The electrometer amplifier consists of two 5886 tubes, V2 and V3, operated as pentodes followed by V4, a 12AU7 twin triode differential amplifier. Local feedback from the triode cathodes to the pentode screens stabilizes the operating point of the electrometer

tubes. Overall negative feedback from the 6C4 output cathode follower, V5, to the electrometer tube filaments stabilizes the amplifier gain. The power supply for the micro-microammeter is derived from the Sola transformer through transformer T2 and utilizes conventional rectifier-filter systems.

The megohmmeter is calibrated by means of R128 and R129 on SW3. With 10^7 ohms in the circuit (R127), the meter is set to 10^7 ohms by adjusting diode bias with R106. Subsequently the meter is set to 10^{11} ohms by adjusting amplifier gain with R124. Occasionally amplifier balance should be checked by turning SW3 to 1x, 10x or 100x position with the lever switch in DISCHARGE. Under these conditions the panel meter should read 10^7 ohms. If adjustment is necessary, R115 is used.

SECTION III OPERATION

The Model 510 Megohmmeter is shipped with the Model 51036 Test Leads. To use this combination for measuring resistances, the following procedure should be followed:

- a. Plug the power cord into 110 volts 60 cps ac. A Sola constant voltage power transformer is used in the Model 510, and its proper functioning depends upon a constant power line frequency of 60 cps. A 50 cps model is available.
- b. Turn the Test-Charge-Discharge switch to Discharge.
- c. Turn the Calibrate-Test Potential switch to Calibrate, 10^7 ohms.
- d. Turn the power switch to ON, and wait a minute or two for the tubes to reach operating temperature.
- e. Set the Cal 10^7 potentiometer located on the panel under the meter, so the meter reads exactly 10^7 .
- f. Turn the Calibrate-Test Potential switch to Calibrate 10^{11} ohms.
- g. Adjust the Cal 10^{11} potentiometer so that the meter reads exactly 10^{11} .
- h. Connect the test leads to the Megohmmeter by fastening the connector end to the input connector on the front panel. Clip the free ends to the unknown resistance. The small, flexible wire is at ground potential. The larger coaxial cable is the guarded HI lead.
- i. Turn the Calibrate-Test Potential switch to apply the desired potential to the unknown resistance.
- j. Switch the Test-Charge-Discharge switch to Charge, and then to Test. The nature of the unknown determines the length of time to remain in the Charge position. If there is little capacitance (0.1 mfd or less) across the unknown resistance, a second or so is long enough; greater capacitance

will require a longer wait. The Model 51036 Test Leads employ a capacitor to reduce the effects of 60 cps pickup, which slows the response appreciably when measuring resistances above about 10^{11} ohms. Some resistance specifications require an "electrification time", which is the interval between applying the test potential and reading the resistance. The ASTM pamphlet, included in this Manual, discusses this in detail. The electrification time is measured from the time the Test-Charge-Discharge switch is moved from Discharge to Charge.

k. After measuring, return the Test-Charge-Discharge switch to Discharge. The instrument is now ready for the next test specimen. With the switch in the Discharge position, all testing conductors are at ground potential, so that specimens can be changed without danger of shock to the operator.

After the instrument has been connected, turned on, warmed up, calibrated, and the test voltage selected, the operating procedure for measuring a number of resistances is very simple. Just connect the unknown to the test clips; turn the Test-Charge-Discharge switch to TEST; read the meter; return the switch to DISCHARGE: and then change to a new unknown resistor.

l. After the instrument has been operating for about five minutes, it should be realigned to eliminate the effects of warmup drift. After this has been done, no more calibrations should be necessary during the following eight hour period.

m. To rebalance the amplifier, set the Calibrate-Test Potential switch to 5 volts, and the Test-Charge-Discharge switch to Discharge. Then adjust the Amp. Bal. potentiometer, on the left side of the cabinet, so that meter reads 10^7 . This adjustment is required only every month or so.

The operating procedure is the same for test leads, fixtures, or the Keithley 5101 or 5102 Adapters. A wide variety of specialized setups is discussed in the Appendix.

When designing special testing fixtures, leads, or electrodes, provision must be made for operating the relay in the Model 510 to remove the short circuit at the input of the micro-microammeter. Pins 2 and 3 of the connector carrying the cable from the unknown to the Model 510 input can be jumpered in the connector, or a switch to connect them can be made a part of the special fixture, following the design of the switch in the Models 5101 and 5102 adapters.

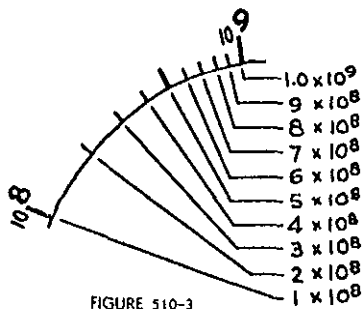

FIGURE 510-3

Reading the Meter: Fig. 510-3 is an enlarged sketch of one decade of the meter scale. 10^8 and 10^9 are the major division marks. The integers between them are also marked, with the 5 line made longer and heavier for quick identification. The other decades are read in a similar manner.

SECTION IV MAINTENANCE

A. General

The Keithley Model 510 Megohmmeter has been designed to give long, trouble-free service. High quality components have been used throughout.

DR 11504-C, page IV-2, is the detailed circuit schematic diagram of the Model 510. The circuit operation was discussed in Section II, DESCRIPTION.

Maintenance Adjustment is R411, which sets the 500 volt test potential. As discussed in Section II, small variations from 500 volts do not affect the calibration of the Model 510; but for proper functioning of the power supply, it should be set within about 5% of 500 volts. To readjust the test potential with R411, connect a high impedance voltmeter (20,000 ohms per volt) from Guard to Ground, set the Calibrate-Test Potential switch to 500 volts and the Test switch to TEST. Adjust R411 for 500 volts test potential.

Resetting R411 is not necessary under normal circumstances, even though the tubes in the regulator have been changed, but it should be checked after a tube change.

The tubes used in the V2 and V3 positions are selected, matched and labelled EV-5886-5 and EV-5886-6 respectively. Replacements are sold in pairs only. The tube used at V1 is not selected.

When inspecting or replacing the electrometer tubes, the glass base should not be touched with the hands, because the dirt and moisture will cause leakage from the grid to the other electrodes. Also, when soldering high impedance conductors to the teflon standoffs, care should be taken to keep the teflon clean.

All vacuum tubes, other than the 5886's are conventional, and selection of replacements is not necessary.

Calibrate - Test Potential Switch and RE1 should be inspected periodically, and any dust which has accumulated on the insulation should be removed by brushing with a camel's hair brush.

Servicing. DR 11698-C, page IV-3, shows the tube layout. Included are the voltage and resistance measurements which may be made at each tube element under specified conditions.

ISSUE	
DATE	
SER. NO.	
CHANGE	

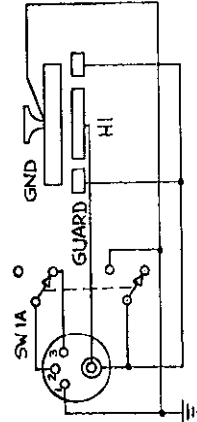

MODEL 5101

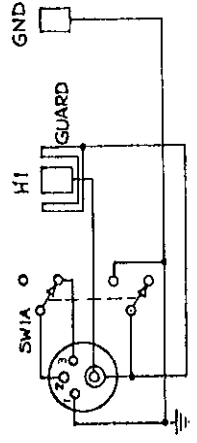

MODEL 5102

SW1A SHOWN IN COVER-CLOSED POSITION. CONNECTOR IS CANNON RSK-UA-24 3/8" ACIAN

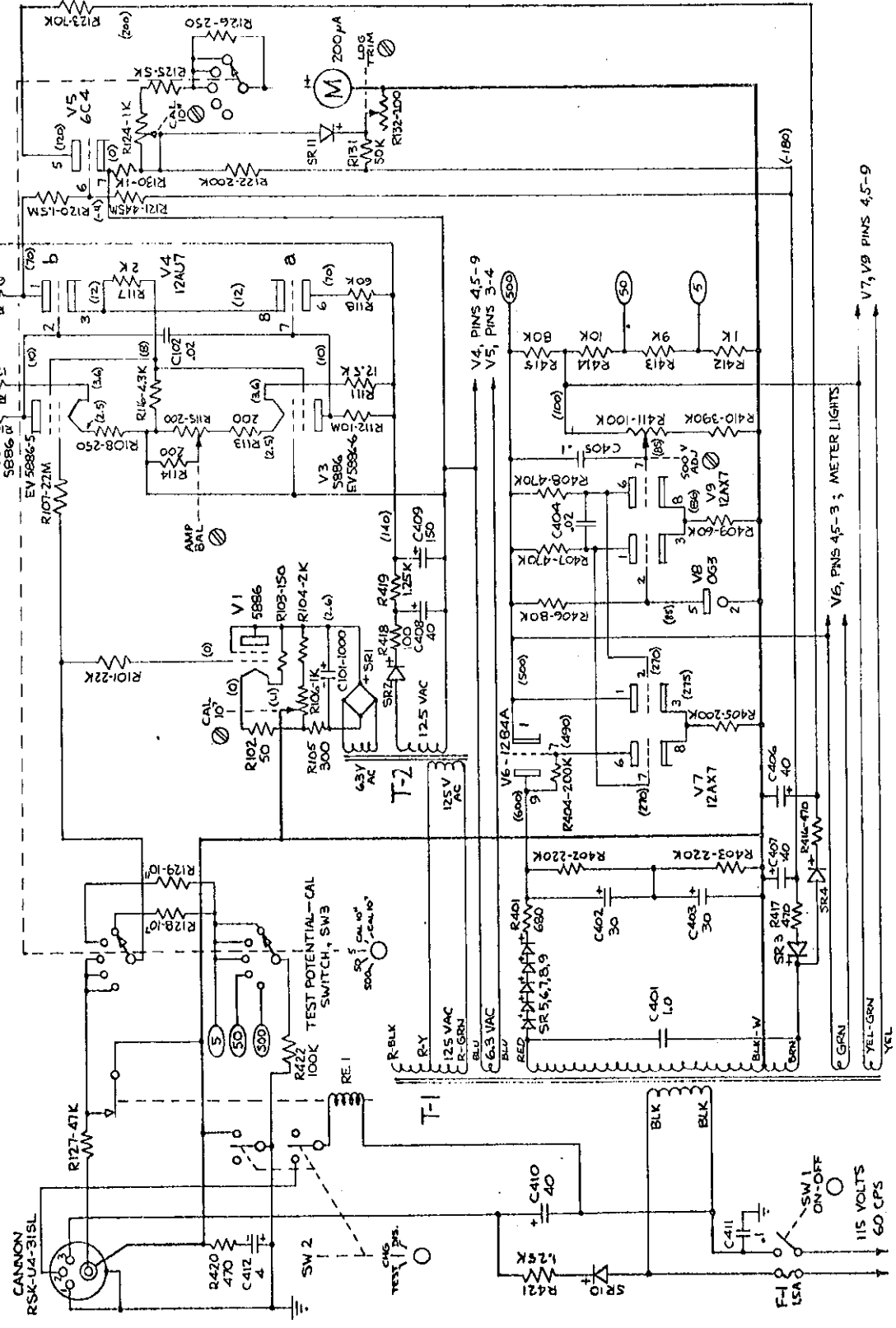

NOTES:
 CAPACITOR VALUES IN MICROFARADS UNLESS OTHERWISE SPECIFIED.
 RESISTOR VALUES IN OHMS UNLESS OTHERWISE SPECIFIED: K=1000 OHMS M=MEG OHMS.
 PANEL CONTROLS ARE SHOWN THUS: ○
 SCREWDRIVER ADJUSTMENTS ARE SHOWN THUS: ⊗
 VOLTAGES SHOWN () ARE MEASURED WITH 10-MEGOHM VTVM WITH "TEST POTENTIAL-CAL" SWITCH IN "5-VOLT POSITION AND "TEST-CHARGE-DISCHARGE" SWITCH IN DISCHARGE POSITION.

MODEL 510 MEGOHMMETER AND ACCESSORIES	
CIRCUIT SCHEMATIC DIAGRAM	
KEITHLEY INSTRUMENTS, INC. CLEVELAND, OHIO	
WEEK	1-6-58
DR	11504-C

V4, PINS 4,5-9
 V5, PINS 3-4
 V6, PINS 4,5-3; METER LIGHTS
 V7, V9 PINS 4,5-9
 115 VOLTS
 60 CPS

VOLTAGE AND RESISTANCE CHART

MEASUREMENTS FROM TUBE PIN TO GROUND USING VTVM WITH 10 MEGOHM INPUT RESISTANCE. TEST POTENTIAL-CALIBRATE SWITCH SET AT 5 VOLT POSITION; LEVER SWITCH AT DISCHARGE POSITION.

ALL READINGS ARE APPROXIMATE. RESISTANCES ARE GIVEN IN OHMS; K=1000, M=MEGOHMS.

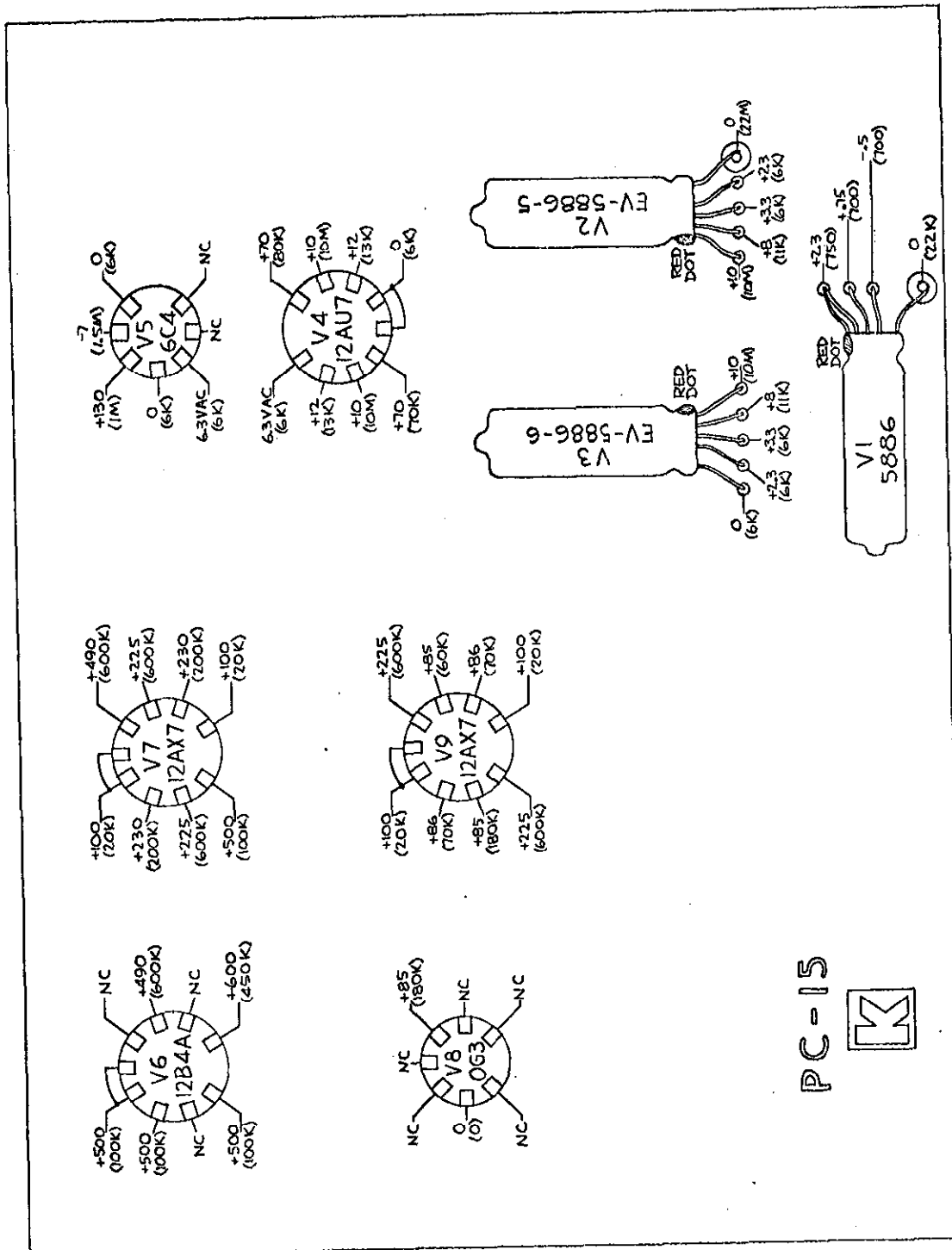

REPLACEABLE PARTS LIST - MODEL 510

Circuit Desig.	Description	Part No.
C101	Capacitor, electrolytic, tubular, 1000 mfd, 12V.	C11-1000
C102	Capacitor, ceramic disc, .02 mfd, 600V.	C22-.02
C401	Capacitor, oil, 1.0 mfd. (supplied with T1)	-
C402	Capacitor, tubular, electrolytic, 30 mfd, 450V	C8-30
C403	Same as C402	-
C404	Same as C102	-
C405	Capacitor, molded paper, 0.1 mfd, 600V	C2-0.1
C406	Capacitor, tubular, electrolytic, 40 mfd, 250V	C27-40
C407	Same as C406	-
C408	Same as C406	-
C409	Capacitor, tubular, electrolytic, 150 mfd, 150V.	C23-150
C410	Same as C406	-
C411	Same as C405	-
C412	Capacitor, tubular, electrolytic, 4 mfd, 600V.	C35-4
F1	Fuse, 1.5 amp. 3AG	FU 8
M	Panel meter, 0-200 microamp	ME 9
R101	Resistor, composition, 22K, 10%, $\frac{1}{2}$ W	R1-22K
R102	Resistor, deposited carbon, 50 ohm, 1%, $\frac{1}{2}$ W	R12-50
R103	Resistor, deposited carbon, 150 ohm,	R12-150
R104	Resistor, deposited carbon, 2K, 1%, $\frac{1}{2}$ W	R12-2K
R105	Resistor, deposited carbon, 300 ohm, 1%, $\frac{1}{2}$ W	R12-300
R106	Potentiometer, composition, 1K	RP13-1K
R107	Resistor, composition, 22M, 10%	R1-22M
R108	Resistor, deposited carbon, 250 ohm, 1%, $\frac{1}{2}$ W	R12-250
R109	Resistor, deposited carbon, 10M, 1%, 1W	R13-10M
R110	Resistor, wirewound, 12.5K, 3%, 7W	R7-12.5K

REPLACEABLE PARTS LIST - MODEL 510

Circuit Desig.	Description	Part No.
R111	Same as R110	-
R112	Same as R109	-
R113	Resistor, deposited carbon, 200 ohm, 1%, $\frac{1}{2}W$	R12-200
R114	Same as R113	-
R115	Potentiometer, composition, 200 ohm	RP13-200
R116	Resistor, deposited carbon, 4.3K, 1%, $\frac{1}{2}W$	R12-4.3K
R117	Same as R104	-
R118	Resistor, deposited carbon, 60K, 1%, $\frac{1}{2}W$	R12-60K
R119	Same as R118	-
R120	Resistor, deposited carbon, 1.5M, 1%, $\frac{1}{2}W$	R12-1.5M
R121	Resistor, deposited carbon, 4.45M, 1%, $\frac{1}{2}W$	R12-4.45M
R122	Resistor, deposited carbon, 200K, 1%, $\frac{1}{2}W$	R12-200K
R123	Resistor, deposited carbon, 70K, 1%, $\frac{1}{2}W$	R12-70K
R124	Same as R106	-
R125	Resistor, deposited carbon, 5K, 1%, $\frac{1}{2}W$	R12-5K
R126	Resistor, deposited carbon, 250 ohm, 4%, $\frac{1}{2}W$	R12-250
R127	Resistor, deposited carbon, 47K, 1%, $\frac{1}{2}W$	R12-47K
R128	Same as R109	-
R129	Resistor, hi-meg, 10^{11} ohms	R20- 10^{11}
R130	Resistor, deposited carbon, 1K, 1%, $\frac{1}{2}W$	R12-1K
R131	Resistor, deposited carbon, 50K, 1%, 1W	R13-50K
R132	Same as R115	-
R401	Resistor, composition, 680 ohm, 10%, $\frac{1}{2}W$	R1-680
R402	Resistor, composition, 220K, 10%, 1W	R2-220K
R403	Same as R402	-

REPLACEABLE PARTS LIST - MODEL 510

Circuit Desig.	Description	Part No.
R404	Resistor, deposited carbon, 200K, 1%, $\frac{1}{2}W$	R12-200K
R405	Same as R404	-
R406	Resistor, wirewound, 80K, 1%, 10W	R30-80K
R407	Resistor, deposited carbon, 470K, 1%, $\frac{1}{2}W$	R12-470K
R408	Same as R407	-
R409	Resistor, deposited carbon, 60K, 1%, $\frac{1}{2}W$	R12-60K
R410	Resistor, deposited carbon, 390K, 1%, $\frac{1}{2}W$	R12-390K
R411	Potentiometer, composition, 100K	RP12-100K
R412	Resistor, deposited carbon, 1K, 1%, 1W	R13-1K
R413	Resistor, deposited carbon, 9K, 1%, 1W	R13-9K
R414	Resistor, deposited carbon, 10K, 1%, 1W	R13-10K
R415	Same as R406	-
R416	Resistor, composition, 470 ohm, 10%, $\frac{1}{2}W$	R1-470
R417	Same as R416	-
R418	Resistor, composition, 100 ohm, 10%, $\frac{1}{2}W$	R1-100
R419	Resistor, wirewound, 1250 ohm, 5%, 5W	R4-1250
R420	Same as R416	-
R421	Same as R419	-
R422	Resistor, composition, 100K; 10%, 2W	R3-100K
RE1	Relay, special	RL1M
SR1	Rectifier, selenium bridge	RF 6
SR2-SR9	Rectifier, selenium, 130V, 65 ma printed circuit style	RF10
SR10	Rectifier, selenium, 130V, 65 ma	RF8
SR11	Silicon alloy diode, Pacific Semiconductor #PS695	RF13
SW1	SPST Bat Handle toggle switch	SW-14

REPLACEABLE PARTS LIST - MODEL 510

Circuit Desig.	Description	Part No.
SW2	DPDT Bat Handle toggle switch (center off)	SW-42
SW3	3 pole, 5 position rotary switch, special	SW-39
T1	Power transformer, Sola 71354 (includes C401)	TR17
T2	Power transformer Stancor PS8416	TR20
V1	Vacuum tube, type 5886	EV-5886
V2	Vacuum tube, type 5886 { sold as matched pair	EV-5886-5
V3		EV-5886-6
V4	Vacuum tube, type 12AV7	EV-12AV7
V5	Vacuum tube, type 6C4	EV-6C4
V6	Vacuum tube, type 12B4A	EV-12B4A
V7	Vacuum tube, type 12AX7	EV-12AX7
V8	Vacuum tube, type 0G3	EV-0G3
V9	Same as V7	-
	Input connector, 5 conductor, Cannon RSK-U4-31SL	CS-26
	Pilot lamp, #51 (two per instrument)	PL8

APPENDIX

Section i Accessories

Model 51036 Test Leads consist of a 36 inch double shielded cable, a 36 inch ground lead and a connector which mates with the Model 510 input connector. The leads are terminated with alligator clips. Use of the Model 51036 is described in Section ii, Component Measurements.

Model 5101 Component Adapter is a shielded enclosure to be used with the Model 510 when testing resistors, capacitors and other small parts. It is designed to attach directly to the Model 510 Megohm-meter. See Section ii, Component Measurements.

Model 5102 Volume Resistivity Adapter is a shielded enclosure, externally similar to Model 5101. It has a set of electrodes which facilitate making volume resistivity measurements and is fully described in Section ii, Volume Resistivity.

Models 51024 and 51060 Cables are used with either of the above adapters when it is desirable to separate the adapter from the Model 510. The cables are 24 and 36 inches long, respectively.

Section ii Measuring Technique

INTRODUCTION

The American Society for Testing Materials has prepared a booklet, D257-54T, "Tentative Methods of Test for Electrical Resistance of Insulating Materials," which describes the procedures for measuring the important parameters of insulating materials. A reprint is included as a part of this instruction book.

The Model 510 with its accessories is an excellent instrument for making the tests, and the following paragraphs will describe testing procedures in detail, with special emphasis on the precautions necessary to obtain accurate measurements of the very high resistances which the extreme sensitivity of the Model 510 permits.

Three major difficulties are encountered in measuring extremely high resistances. They are: a) 60 cps pickup by the high impedance conductors; b) spurious current leakages; and c) charges and currents generated by sliding or deforming the insulating sample.

60 cps pickup is eliminated by shielding the input, test circuit conductors, and the specimen, as in the Models 5101 and 5102 adapters; or by using a capacitor across the micro-microammeter as in the special case of the Model 51036 Test Leads.

Spurious current leakage is avoided by using excellent insulation material, such as teflon or polyethylene, in the test leads and fixtures, and by guarding all leakage paths.

The spurious charges, or "static electricity," can be avoided by handling the test sample as little as possible before measuring it. A 200 foot piece of polyethylene coaxial cable, for example, can lose charges at the rate of 10^{-13} ampere for several hours after it has been flexed moderately.

Electrification time, voltage and temperature coefficients, and moisture or solvent content are also important considerations when measuring insulation resistance.

SPEED OF INDICATION

The measurement of the leakage resistance of capacitors with the Model 510 involves long times when the product of the resistance and capacitance is large. The capacitor is charged quickly to the test potential by the Test-Charge-Discharge switch, bringing the reading on scale, but reading equilibrium is often a slow process. The following empirical expression gives T, the time in seconds for the 510 to read within 10% of the final resistance value:

$$T = \frac{RC}{4E} \quad \text{where } R \text{ is the leakage resistance in ohms}$$

C is the capacitance in farads
E is the test potential in volts

Faster response can be obtained by using a battery to furnish the test potential, and Keithley Models 200B and 2008 combination to read the leakage current. Using the 200B on the 0.008 volt range permits the lowest practical shunt resistor in the 2008, which is substantially smaller than the effective diode resistance in the Model 510 at equilibrium.

As an example, consider the measurement of a 5000 mmf capacitor with a leakage resistance of 10^{13} ohms. The 510 with 50 volts applied to the sample will read within 10% of 10^{13} in about 4 minutes. The 200B, using the .008 volt range, with a 10^9 ohm shunt and 50 volt supply will read within 10% of final current in about 12 seconds.

COMPONENT MEASUREMENTS

Measuring with Model 51036 Test Leads: The Model 510 is shipped with the Model 51036 Test Leads for general purpose use. These leads are intended for measuring unshielded objects such as resistors, insulating terminals, and the coil-to-coil and coil-to-frame insulation of motors of transformers.

The Test-Charge-Discharge switch should be in the Discharge position when changing specimens, otherwise the test potential appears across the alligator clips. This is particularly dangerous when testing capacitors at 500 volts.

When measuring capacitors, the switch should remain in the Charge position long enough to assure that the capacitor is completely charged before moving the switch to the Test position.

The effects of 60 cps pickup by the specimen are eliminated by a 500 mmf capacitor located in the connector housing and connected across the input of the micro-microammeter. Because of the capacitor, however, the response of the amplifier and meter are slowed. For instance, to read 90% of final value in 2.5 seconds, one may measure 10^{11} ohms using 5 volts test potential, 10^{12} ohms with 50 volts, and 10^{13} ohms with 500 volts. Higher readings require proportionately longer times. For fast measurement of high resistances, the object being measured must be shielded from 60 cps pickup, and the micro-microammeter not slowed with a capacitor.

The detailed steps of lining-up and making measurements with the Model 510 were given in Section III, OPERATION.

Measuring with the Model 5101 Component Adapter: The Keithley Model 5101 Component Adapter is a convenient shielded enclosure for holding electronic components, such as resistors or capacitors, while their resistance is being measured. It connects directly to the Model 510. The circuit schematic diagram is given on DR 11504-C, the main diagram for the Model 510.

For most components, the most convenient connections are two spring clips on banana plugs (Grayhill #2-1), one plugged into GND and the other into HI. The component leads slip easily into the springs which hold the component from touching the box or the relatively low resistance insulation. Two clips are furnished with each 5101 Adapter.

Closing the lid of the box operates switch SW1. One section ungrounds the Guard circuit, and the other operates relay R1 in the Megohmmeter, which opens the input to the micro-microammeter.

Opening and closing the lid performs all the necessary switching when changing samples.

VOLUME RESISTIVITY:

Volume resistivity is determined by measuring the resistance of an insulation sample, as described in the ASTM Specification Section 4 (b), and reducing the geometry to an equivalent cube, as shown in Section 9 of the Specification. Fig. 4 shows the most popular electrode configuration whose dimensions are usually measured in centimeters, giving the volume resistivity in ohm-centimeters.

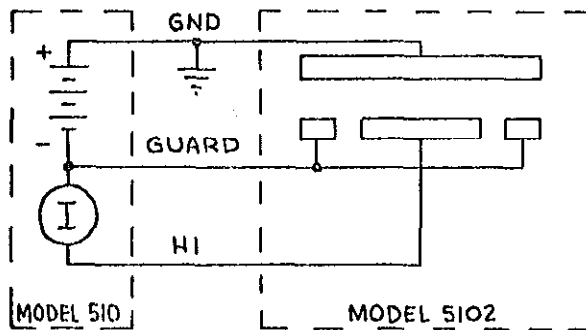
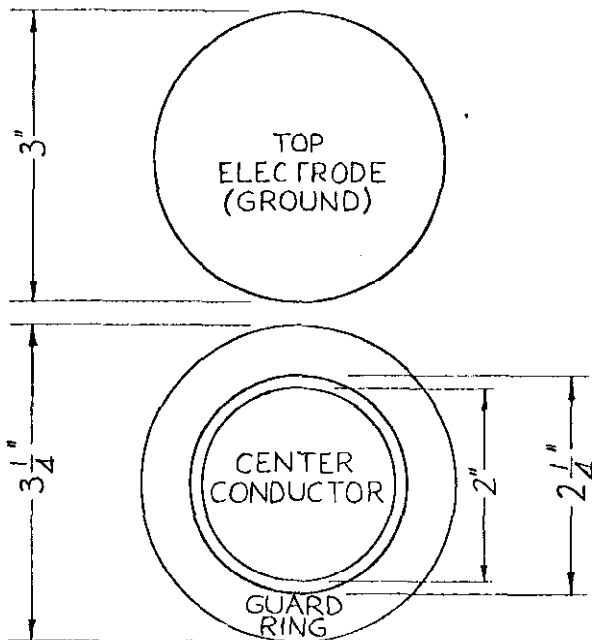

Fig. 510-5 is a simplified diagram of the Models 510 and 5102 for measuring volume resistance with this type of electrodes.

FIGURE 510-5

The Keithley Model 5102 Volume Resistivity Adapter provides the desired electrode configuration in a shielded box which can be connected directly to the Model 510. Graphite, or aquadag, or silver conducting paint electrode patterns should be painted or stencilled on the surfaces, as described in the ASTM Specification. The electrode dimensions of the Model 5102 are given below.



The conversion of the resistance reading of a sample into resistivity units is given by

$$P = 2 \frac{D^2 R}{t}$$

- where P = resistivity in ohm-centimeters
- D = center electrode diameter in inches
- t = sample thickness in inches
- R = resistance reading in ohms

The electrode structure in the Model 5102 is designed to be used with a center electrode diameter of two inches. For this case,

$$P = \frac{8 R}{t} \text{ ohm-centimeters}$$

ELECTRODE DIMENSIONS MODEL 5102
 NOTE: MAXIMUM SAMPLE THICKNESS IS $\frac{1}{4}$ INCH.

While the diameter of the specimen is set by electrode structure, any thickness of sample up to $\frac{1}{4}$ inch may be tested.

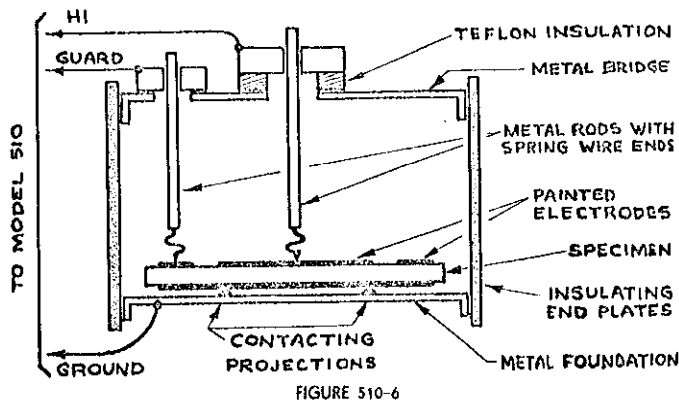

FIGURE 510-6

Fig. 510-6 shows a holder for large rigid specimens which are not suited to the Model 5102. A spring is used on the end of a rod to make the connections. Note that the high impedance conductor is well guarded.

If the specimen has a resistance greater than about 10^9 or 10^{10} ohms, the test fixture should be inside a grounded enclosure to

prevent 60 cps pickup by the HI conductor.

The Keithley Model 5101 Component Adapter makes a convenient enclosure for measuring small rigid samples. A table can be plugged into the ground jack, and springs which contact the HI and Guard electrodes can be connected to plugs which are inserted into the HI and Guard jacks.

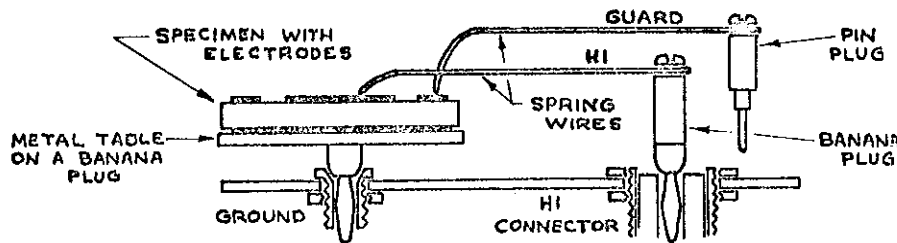

FIGURE 510-7

Fig. 510-7 is a diagram of the Model 5101 used in this fashion.

Measuring Volume Resistivity using the Model 5101 Component Adapter.

If temperature coefficients of resistance or the high temperature performance of insulating material are of interest, the specimen and holder are mounted in an oven.

For temperatures up to about 120°F , the Model 5101 or 5102 adapters are suitable. Accessory cables Models 51024 or 51060 are available for connecting between the Models 510 and the adapter.

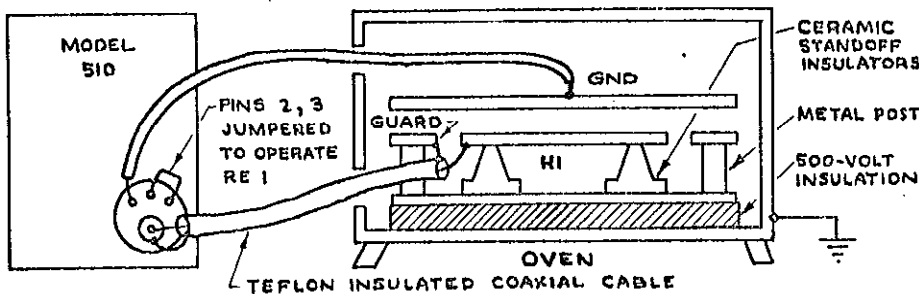

FIGURE 510-8

Above 120°F , a special fixture is required, designed to withstand the heat. Fig. 510-9 shows such a fixture in an oven connected to the Model 510. The insulation in the fixture is ceramic or teflon, and the connecting cable uses teflon insulation, because polyethylene softens at elevated temperatures.

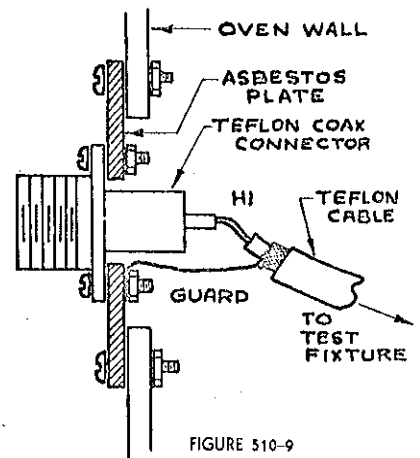

FIGURE 510-9

The Guard and HI electrodes must be mounted so that at operating temperatures they are in the same plane.

Fig. 510-8 shows the connecting cables passing directly through holes in the oven walls. If it is desired to mount connectors in the oven walls, Fig. 510-9 shows the details of a typical installation. Teflon insulated connectors, such as MIL Type O-239A should be used. The shell of the HI lead connector which is operated at Guard potential must be insulated electrically from the oven wall which should be at Ground. Some protection must be provided for the operator, because the exposed parts of the plug can be 500 volts below ground.

The metal housing of an oven generally makes a good shield against 60 cps pickup, and should be connected to ground. Difficulties may arise through pickup of the 60 cps voltages from exposed conductors or heating coils and from door hinges which are not conducting and tend to insulate the door from the cabinet. In most cases, no shielding in addition to the grounded metal oven and shelves is necessary.

One of the constituents of teflon is fluorine. At room temperature, teflon is chemically stable, but when elevated above about 500°F., it gives off toxic fumes. Great care should be taken when using teflon cables in ovens or near heating elements.

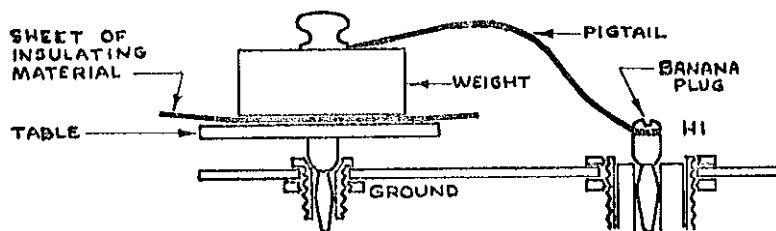

FIGURE 510-10

Figure 510-10 illustrates a variation of the guarded electrode connection for measuring volume resistivity of these sheets, or for quick comparisons of resistances between sheets. Here, the surface leakage path is very long,

and, with materials which are known to have good surface properties, the surface resistance is much higher than the volume resistance. The weight is chosen large enough and heavy enough to give consistent measurements.

The Model 5101 Component Adapter makes a convenient shielded enclosure for these measurements. A metal plate fastened to a banana plug slipped into the GND jack is a convenient measuring table. The weight is connected by a short pigtail to a banana plug slipped into the HI terminal. There is no Guard connection, and the pigtail from the high terminal to the weight must not touch anything.

A source of serious error in measuring the volume resistivities of the better insulators is conductivity between the HI and Guard conductors, both on the surface of the sample itself and in the connections to the megohmmeter input. This provides a current path in addition to the microammeter of the megohmmeter, causing the meter to read an erroneously low resistance.

For example using the 5 volt test potential, the desired current when reading 10^{13} ohms falls through a potential field of about 6.5 volts, whereas the undesired current from guard to input falls through a field of 1.5 volts. Thus, with equal currents, desired and undesired, the leakage

resistance from guard to high could be

$$\frac{1.5}{6.5} \times 10^{13} = 2.3 \times 10^{12} \text{ ohms.}$$

For the undesired current to cause less than 10% error would require a leakage resistance higher than 2.3×10^{13} ohms between high and guard.

On the 50 volt test potential, the test current source is about 51 volts and the leakage current source is still about 12 volts, so that now the leakage resistance may be 2.4×10^{12} ohms for less than 10% error.

Similarly, on the 500 volt test potential, the leakage resistance may be 2.4×10^{11} .

In short, then, if surface leakage is a problem, the best results will be obtained at the highest test potential. This is because with virtually constant undesired current, the relative error is less with higher values of actual test current.

This error may occur particularly in the case of a glass plate on which electrodes are applied by vacuum depositing metal films. The volume resistance of the plate is very high, but the narrow surface between the electrode is easily contaminated by the water vapor from the air, or by water films, oil films and salts resulting from fingerprints.

Similar problems can arise if the graphite used in making an electrode on a sample is streaked across the gap to the Guard, or if the sample is put on the rings of the volume resistivity holder so that it is poorly centered, and the HI and Guard are nearly short circuited by the central electrode.

MEASURING WITH TEST LEADS TO A SHIELDED ENCLOSURE

When resistance greater than those practical with the Model 51036 Test Leads are to be measured, test connections without the added capacitance across the micro-microammeter section must be used. But the leads and the test object must then be thoroughly shielded against 60 cps pickup. The

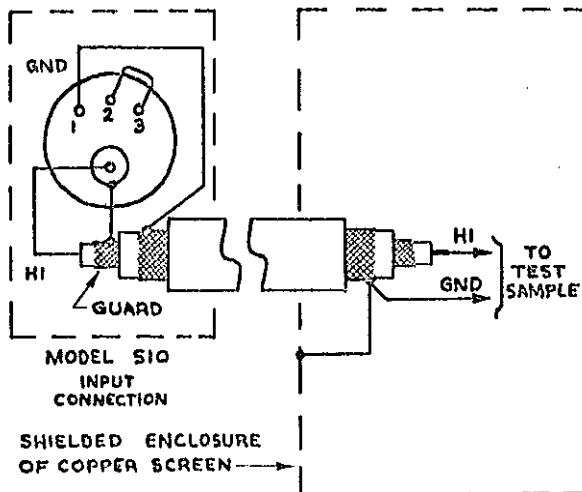

FIGURE 510-11

Keithley Model 5101 Component Adapter is a convenient completely shielded accessory for holding small objects. For larger objects, specially build shielded enclosures is necessary, and the connection to the Megohmmeter must be made with guarded cable. Fig. 510-11 shows an enclosure made with copper screening, and connections made to the Megohmmeter with double shielded cable. The cable and connector can be obtained from Keithley Instruments, Inc., on special order.

USE OF OTHER THAN STANDARD TEST POTENTIALS

The occasion may arise when it is necessary to measure resistance with a voltage other than 5, 50 or 500. Although not recommended because of the precautions involved such measurements can be made.

As indicated in Section II - DESCRIPTION, the Model 510 comprises a voltage source and micro-microammeter in series. If additional voltage is used, then, it must be connected in series with the test sample and a suitable factor applied to the resistance reading obtained. Fig. 510-12 shows the connection to be used.

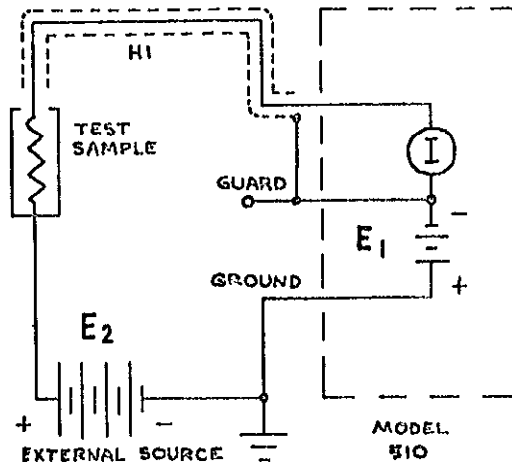

FIGURE 510-12

True resistance is found by multiplying the reading by $\frac{E_2 + E_1}{E_1}$.

Thus, in testing with an external 4500 volt source with the Model 510 on its 500 volt test potential, the actual resistance is ten times the value indicated by the 510 alone.

When using this arrangement the following points should be noted:

1. Guard potential is available and useful as indicated previously for guarding the HI lead and for driving any guard rings which may be employed.
2. The sample is above ground by the potential E_2 and care must be exercised in handling samples. The discharge switch cannot discharge the sample except for the contribution of E_1 .
3. All previous comments regarding shielding against stray 60 cps pickup apply.
4. E_2 must be a very stable source if the reading is to be valid. A battery is preferable in most cases especially if the test sample is capacitative.
5. Measurement speed, discussed in Section IV B, is calculated as indicated with the "E" in the equation being $E_1 + E_2$.
6. Do not use the 5 volt range on the 510 for this test. At low test potentials inaccuracies occur which have been compensated on the 5 volt range. To use a large voltage externally but to compensate as if a low voltage were being used will give erroneous results.
7. If there is danger of the sample's breaking down and applying external test voltage to the Model 510, separate means should be employed to limit the input current to about one milliampere. Thus, with an external 5000 volt supply, a 5 megohm resistor should be used in series with the HI lead. Needless to say, the resistor must be capable of withstanding 5000 volts or it, too, would break down and afford no protection to the Model 510.

RESERVATION RECEIPT

FOR

ADMISSION

TO

AND ACCOMPANIES

PRODUCTION CHARGES

CHANGE THE VALUE OF THIS FROM 2X TO 3X
CHANGE THE VALUE OF THIS FROM 2X TO 3.5X

CHANGE NOTICE

May 29, 1968

MODEL 605 NEGATIVE CAPACITANCE ELECTROMETER

Page 23. Change to the following:

Circuit Desig.	Value	Rating	Type	Mfg. Code	Mfg. Part No.	Keithley Part No.	Fig. Ref.
R117	499 Ω	1%, 1/2 w	DCb	91637	DCF-1/2	R12-499	-
R118	499 Ω	1%, 1/2 w	DCb	91637	DCF-1/2	R12-499	7
R119	499 Ω	1%, 1/2 w	DCb	91637	DCF-1/2	R12-499	7
R120	499 Ω	1%, 1/2 w	DCb	91637	DCF-1/2	R12-499	7
R121	499 Ω	1%, 1/2 w	DCb	91637	DCF-1/2	R12-499	7
R122	499 Ω	1%, 1/2 w	DCb	91637	DCF-1/2	R12-499	7

Page 24. Change to the following:

Circuit Desig.	Value	Rating	Type	Mfg. Code	Mfg. Part No.	Keithley Part No.	Fig. Ref.
R123	499 Ω	1%, 1/2 w	DCb	91637	DCF-1/2	R12-499	7
R124	499 Ω	1%, 1/2 w	DCb	91637	DCF-1/2	R12-499	7
R125	499 Ω	1%, 1/2 w	DCb	91637	DCF-1/2	R12-499	7
R126	499 Ω	1%, 1/2 w	DCb	91637	DCF-1/2	R12-499	7