

INSTRUCTION MANUAL
MODEL 605
NEGATIVE CAPACITANCE
ELECTROMETER

WARRANTY

We warrant each of our products to be free from defects in material and workmanship. Our obligation under this warranty is to repair or replace any instrument or part thereof (except tubes and batteries) which, within a year after shipment, proves defective upon examination. We will pay domestic surface freight costs.

To exercise this warranty, call your local field representative or the Cleveland factory, DDD 216-248-0400. You will be given assistance and shipping instructions.

REPAIRS AND RECALIBRATION

Keithley Instruments maintains a complete repair service and standards laboratory in Cleveland, and has an authorized field repair facility in Los Angeles.

To insure prompt repair or recalibration service, please contact your local field representative or the plant directly before returning the instrument.

Estimates for repairs, normal recalibrations, and calibrations traceable to the National Bureau of Standards are available upon request.

TABLE OF CONTENTS

Section	Page	Section	Page
MODEL 605 SPECIFICATIONS	ii	4. MAINTENANCE.	11
1. GENERAL DESCRIPTION.	1	4-1. General.	11
1-1. General.	1	4-2. Parts Replacement.	11
1-2. Features	1	4-3. Special Maintenance Precautions.	11
2. OPERATION.	3	4-4. Troubleshooting.	13
2-1. Input Head	3	4-5. Procedures to Guide Troubleshooting.	14
2-2. Power Module	3	4-6. Calibration.	14
2-3. Operating Procedure.	3	5. ACCESSORIES.	19
2-4. Line Frequency Noise and Minimum Response Speed	5	5-1. Model 6051 Mounting Bracket.	19
2-5. Capacitance Tuning	6	5-2. Model 6052 Integrator.	19
2-6. Microelectrode Resistance Measurement.	7	5-3. Model 6053 Cable	19
2-7. Drift, Grid Current and Ringing.	7	6. REPLACEABLE PARTS.	21
3. CIRCUIT DESCRIPTION.	9	6-1. Replaceable Parts List	21
3-1. General.	9	6-2. How to Order Parts	21
3-2. Input Head	9	Model 605 Replaceable Parts List	22
3-3. Power Module	10	Schematic Diagram 20387C	27
		Green Repair and Calibration Forms	29

* Change Notice Last Page

* Yellow Change Notice sheet is included only for instrument modifications affecting the Instruction Manual.

TABLE 1. Model 605 Specifications.

INPUT RESISTANCE: Greater than 10^{13} ohms.
INPUT CAPACITANCE NEUTRALIZATION: Up to 100 picofarads.
GRID CURRENT: Less than 10^{-13} ampere without compensation.

RESPONSE AND NOISE CHARACTERISTICS:

Source	Min. f-3db kilocycles	Max. Rise Time, microseconds (63%) (10-90%)		Max. Input Noise,* microvolts rms
Resistor, megohms				
0	400	—	1	35
10	20	15	20	350
22	15	20	27	450

GAIN: $2 \pm 5\%$.
VOLTAGE SUPPRESSION: Zero may be offset with 10-turn zero control approximately ± 100 millivolts with respect to the input.
DRIFT: Less than 1 millivolt per hour after 1-hour warmup;
less than 1 millivolt per $^{\circ}\text{C}$;
less than 10^{-14} ampere per day;
less than 10^{-14} ampere per $^{\circ}\text{C}$.
DYNAMIC RANGE: ± 1 volt at input.
MAXIMUM INPUT OVERLOAD: ± 100 volts.**
OUTPUT RESISTANCE: Less than 1000 ohms.
CALIBRATION: Ramp required, may be generated by a triangle wave (ramp) generator. An oscilloscope square wave calibrator output may be used when integrated by Keithley Model 6052.
CONNECTORS: Input, Output and Calibrate: BNC. Indifferent Electrode: Spring-loaded clip.
BATTERIES: Five TR286, one E12. 200 hours battery life.
DIMENSIONS, WEIGHT:
Input Head: $1\frac{3}{8}$ " high x $3\frac{1}{4}$ " wide x $2\frac{3}{8}$ " deep;
net weight, 9 ounces (3-foot power cable attached).
Power Module: 2" high x 10" wide x $5\frac{1}{4}$ " deep;
net weight, 3 pounds.
ACCESSORIES SUPPLIED:
Model 6051 Mounting Bracket: Permits head to be supported by ring stand and rod clamp.
BNC to Binding Post adapter, mating input connector.

*Noise measured between 10 cps and 100 Kc with Amplifier tuned for rated rise time.
**May require several minutes to recover to specified drift.

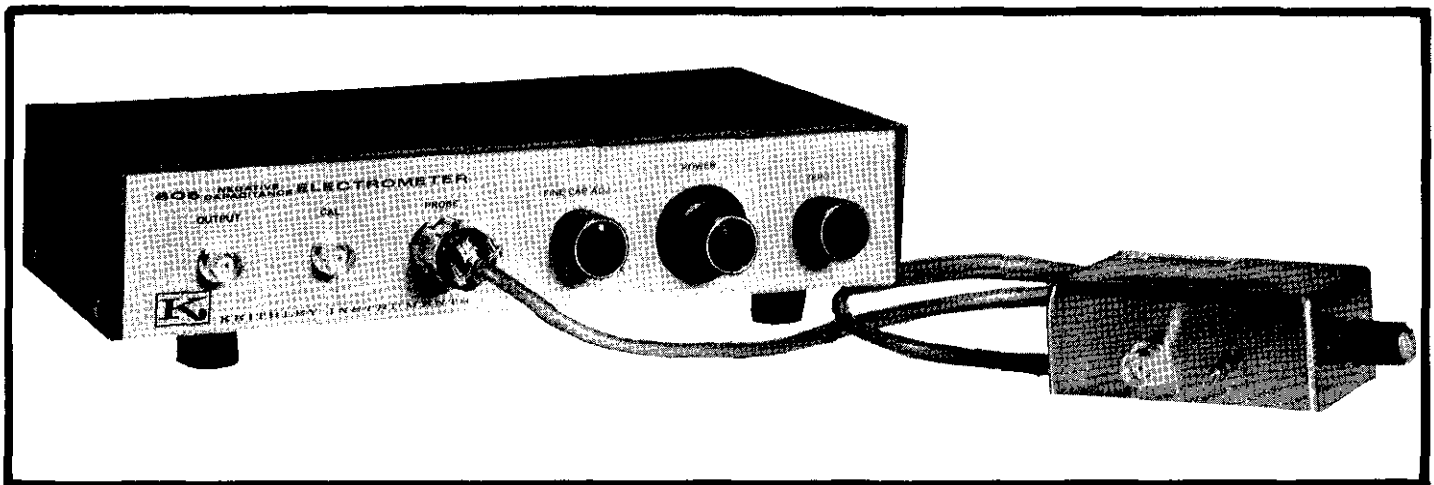

FIGURE 1. Keithley Model 605 Negative Capacitance Electrometer.

SECTION 1. GENERAL DESCRIPTION

1-1. GENERAL. The Keithley Model 605 is a negative capacitance electrometer.

a. What is a negative capacitance electrometer?

1. When a signal from a high impedance source is amplified, the capacitance of the amplifier input and the connecting cable greatly degrades the signal rise time. For example, with only 20-picofarad shunt capacitance, a signal from a 20-megohm source has a 400-microsecond rise time.

2. A negative capacitance electrometer is useful for improving the rise time of signals from high impedance sources. This is accomplished by applying in-phase feedback from the output of a fixed gain amplifier to the input through a properly chosen capacitor. Reducing the effective capacitance in the example to 1 picofarad, possible with the Model 605, improves rise time to 20 microseconds.

1-2. FEATURES.

a. Battery operation allows the Model 605 to operate inside shielded areas without introducing extraneous power line noise.

b. Only three operating controls and a power switch are used: a 10-turn zero potentiometer which compensates for resting potentials and other dc offsets up to 100 millivolts; a control on the input head for preliminary capacitance adjustment; and a fine capacitance adjustment on the power module. The remote location of the fine capacitance control and zero potentiometer allows adjustment without disturbing the experiment.

c. The Model 605 has grid current less than 10^{-13} ampere and current drift less than 10^{-14} ampere per day or per $^{\circ}\text{C}$ without requiring a compensating adjustment. The low grid current minimizes the possibility of polarizing the cell under study.

d. In addition to low grid current, the Model 605 offers input resistance greater than 10^{13} ohms, shunt capacitance adjustable to less than 1 picofarad with a 22 megohm source, and short circuit noise less than 35 microvolts rms. The rise time of less than 20 microseconds with a 22-megohm source permits faithful reproduction of pulse.

e. The power module has an input for a ramp calibrating signal, allowing microelectrode testing and optimum neutralization adjustment without disturbing the test preparation.

TABLE 2. Input Head Controls and Terminals.

The table briefly describes each control and terminal, and indicates the paragraph which contains instructions on the use of the control or terminal.

Control or Terminal	Functional Description	Par.
Cord	Connects the Input Head to the Power Module	2-3
Input Receptacle	Bnc connector for signal input from microelectrode and indifferent electrode	2-3, 2-4
Spring Lock Terminal	Ground post for easy connection of indifferent electrode	2-3
Capacitance Adjust Control	For preliminary adjustments for neutralizing stray capacitances on the input circuitry	2-3, 2-5

TABLE 3. Power Module Controls and Connectors.

The table briefly describes each control and connector, and indicates the paragraph which contains instructions on the use of the control or connector.

Control or Connector	Functional Description	Par.
POWER Switch	Turns the power supply on and off	2-3
ZERO Control	Zeroes the output voltage. Also compensates for resting potentials and other dc offsets.	2-3
FINE CAP ADJ Control	Used for neutralizing small changes of input capacitance	2-3 2-5
PROBE Receptacle	Nine terminal mating connector for the Cord from the Input Head	2-3
OUTPUT Receptacle	Bnc connector for output signal	2-3
CAL Receptacle	Bnc connector to receive ramp calibration signal, allowing microelectrode testing and optimum capacitance neutralization adjustment	2-3

SECTION 2. OPERATION

2-1. **INPUT HEAD.** The Input Head is a small nine-ounce remote head that contains the amplifier, enabling the Model 605 to be placed conveniently anywhere in a crowded experimental system. The Head may be easily mounted in a standard rod and clamp system, using the supplied mounting bracket. The Input Head is chrome plated to minimize corrosion caused by salt solutions, and its tight fitting cover protects the amplifier from spilled solutions.

2-2. **POWER MODULE.** The Power Module contains the operating controls and six mercury batteries to operate the amplifier. Battery power allows the Model 605 to operate inside shielded areas without introducing extraneous power line noise.

2-3. OPERATING PROCEDURE.

a. Connect the Input Head to the Power Module by connecting the nine-lead, shielded Cord from the Input Head to the PROBE Receptacle on the Power Module. Lock the plug on the Cord in place by rotating the outer jacket clockwise.

b. Connect the OUTPUT Receptacle on the Power Module to the input of an oscilloscope, amplifier, potentiometric recorder, or some other suitable monitoring device. The OUTPUT Receptacle is a bnc connector.

c. Apply a triangular wave to the CAL Receptacle on the Power Module.

1. Apply this signal with either a triangular wave generator, or, as shown in Figure 3, with an oscilloscope square-wave calibrator output integrated by the Keithley Model 6052 Integrator. Turn the generator signal to off.

2. The CAL Receptacle is an input for a ramp calibrating signal, allowing microelectrode testing and optimum neutralization adjustment without disturbing the test preparation. (See paragraphs 2-5 and 2-6). The triangular signal is applied at the CAL Receptacle.

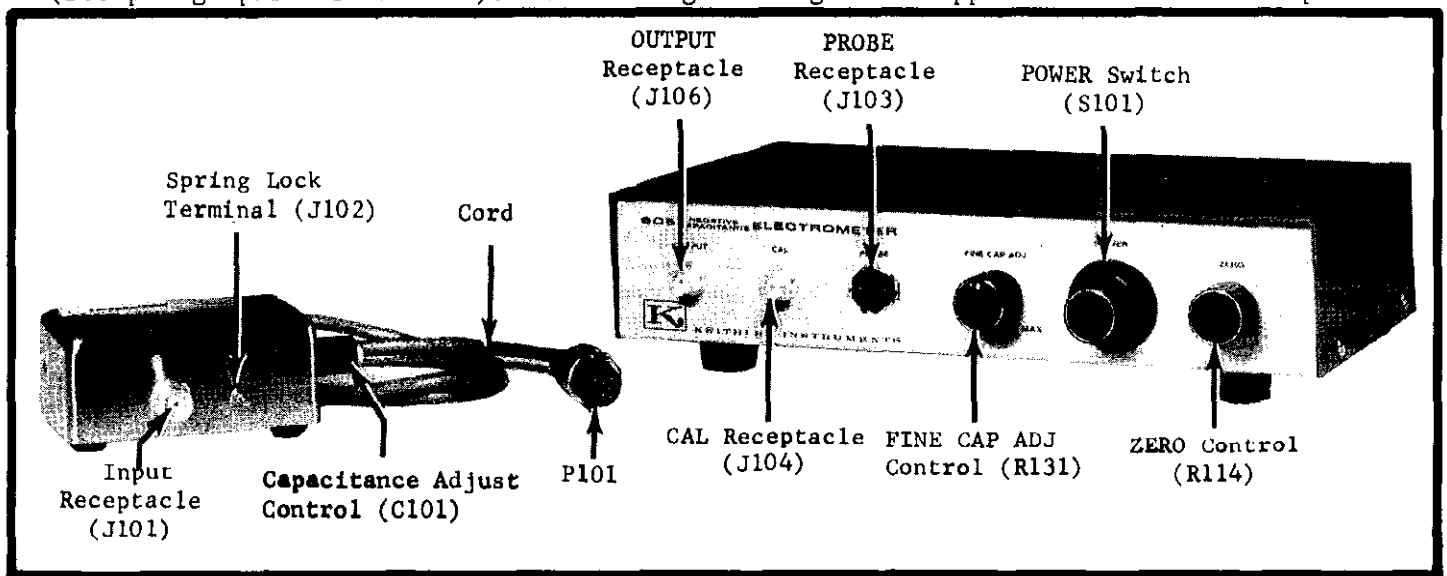

FIGURE 2. Model 605 Controls and Terminals. Circuit designations refer to Replaceable Parts List and schematic diagram.

This signal is differentiated by the RC combination of a 5 picofarad capacitor in the Input Head, C103, and the resistance of the microelectrode connected from the Input to the indifferent electrode through the bath. Thus, a current square wave is applied to the input of the amplifier. Since, however, neither electrode has yet been connected, an appropriate resistor, approximately 22 megohms, can be connected across the Input to simulate the source resistance of a microelectrode.

d. Mount the Input Head with a standard rod and clamp system using the supplied mounting bracket or just place the Head on the bench top.

e. Connect the Input Receptacle on the Input Head to the microelectrode or the calomel cell. Shielded or unshielded cable may be used. For shielded connections, use the mating bnc connector. For unshielded connections, insert a bare wire into the center terminal of the Input Receptacle or use the banana jack adapter.

f. Connect the indifferent electrode to the bath or dish. The indifferent electrode may be connected either to the shield of the mating bnc connector or to the Auxiliary Spring Lock Terminal.

g. Short the tip of the microelectrode to the indifferent electrode by dipping the end of the microelectrode into the salt bath.

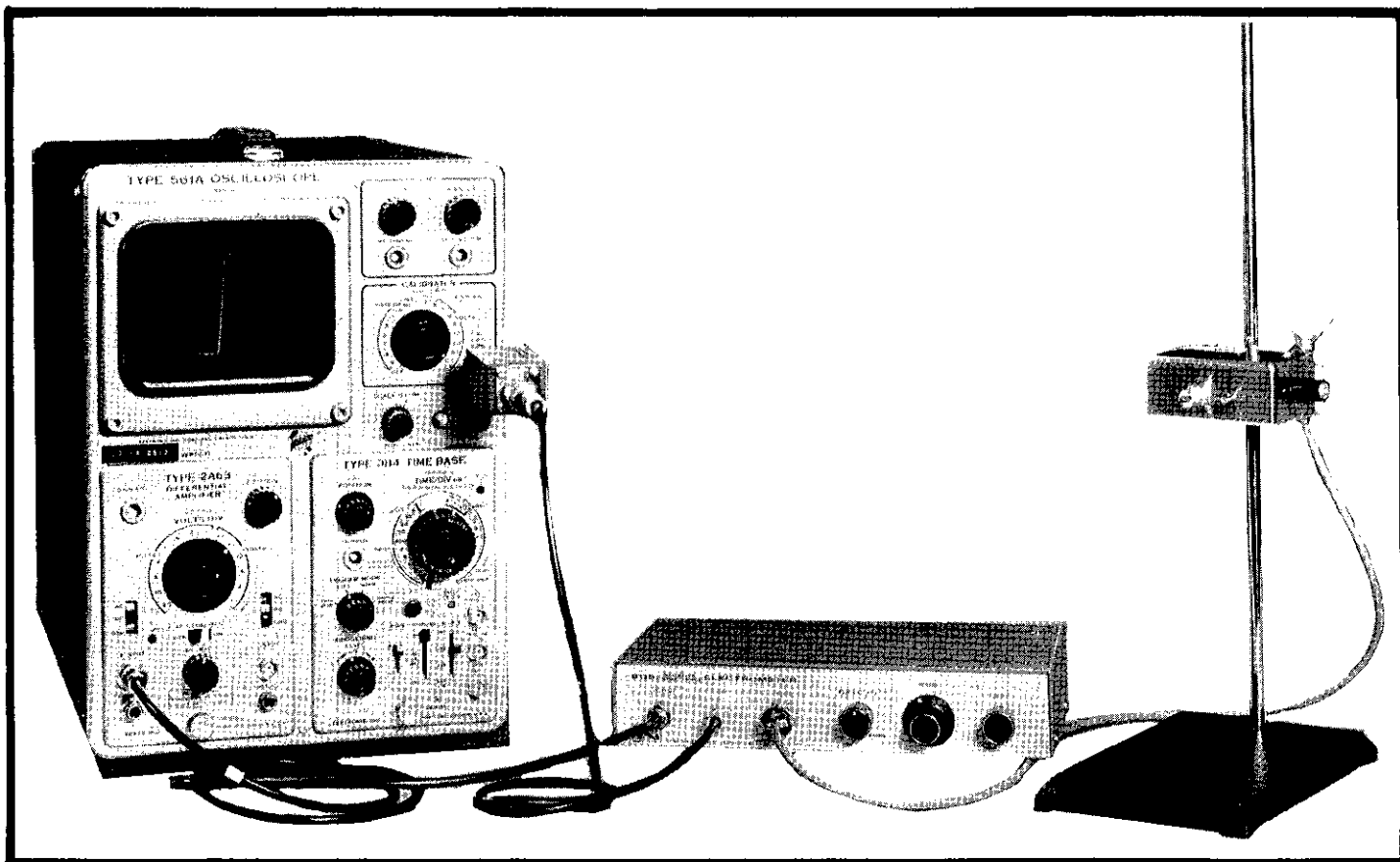

FIGURE 3. The Power Module on the Model 605 has an Input for a Ramp Calibrating Signal, Allowing Microelectrode Testing and Optimum Neutralization Adjustment Without Disturbing any Test Preparation. The ramp signal may be obtained from a ramp generator, or, as shown above, from an oscilloscope square-wave calibrator output integrated by the accessory Keithley Model 6052 Integrator.

- h. Turn POWER Switch on the Power Module to "on". The POWER Switch turns the power supply on and off. The Supply is on when the red dot is visible through the switch knob.
- i. Zero the oscilloscope and observe the output of the Model 605 on the oscilloscope.
- j. Zero the output of the Model 605 with the ZERO Control on the Power Module. Besides zeroing the output, the ZERO Control also compensates for resting potentials and other dc offsets within a span of approximately 100 millivolts.

NOTE

There is no output overload protection on the Model 605. A brief output short circuit will not damage the Model 605, but will cause excessive drain on the batteries.

k. Apply a triangular signal with the signal generator to the CAL Receptacle on the Power Module and note the output on the oscilloscope. Compensate for stray capacitance on the input by adjusting the Capacitance Adjust Control on the Input Head and the FINE CAP ADJ Control on the Power Module. The Capacitance Adjust Control on the Input Head, which is a 55-turn stable glass piston trimmer, because of its fine resolution and wide range, is for preliminary adjustments. The FINE CAP ADJ Control is used for neutralizing small changes of input capacitance, and, since it is on the Power Module, can be used without disturbing the Input Head or the microelectrode.

1. Start with the FINE CAP ADJ Control at MAX (completely clockwise) and the Capacitance Adjust Control on the Input Head in the completely counter-clockwise position.
 2. Turn the Capacitance Adjust Control on the Input Head until the square wave rise time on the oscilloscope decreases. When maximum tolerable overshoot is reached, the input capacitance is nulled.
 3. If fine capacitance adjustment is also necessary, use the FINE CAP ADJ Control.
- l. Turn off the triangular signal to the CAL Receptacle. Do not disconnect the cable between the signal generator and the CAL Receptacle. If the cable is disconnected, the input capacitances will change and the Model 605 will no longer be tuned.

m. Insert the microelectrode into the cell and observe the resting potential, pulses and the response to external stimulæ. The microelectrode resistance can be checked periodically by applying a triangular signal with the signal generator and observing the magnitude of the output square wave (see paragraph 2-6).

NOTE

The Model 605 has a voltage gain of 2. Therefore, be sure to divide the output signal by a factor of 2 when using an oscilloscope, recorder, etc.

2-4. LINE FREQUENCY NOISE AND MINIMUM RESPONSE SPEED. Line frequency noise may be a problem in many measurement setups. There are several ways in which this noise can be eliminated or minimized.

a. Using shielded cable at the Input Receptacle on the Input Head of the Model 605 reduces the noise pickup. However, use of a shielded cable at the input increases the minimum obtainable rise time because of the distributed capacitance of the cable.

b. A shielded room can also reduce line frequency noise. The shielded room is an improvement over the shielded input cable because the rise time is not degenerated. However, there still is line frequency pickup from the electronic equipment used in the experimental setup. To reduce line pickup within a shielded room, a shielded cable can be used. As before, however, the rise time will increase.

c. A wire screen cage and an unshielded input cable is generally the best setup. With this setup almost all the line frequency noise can be excluded. The unshielded input cable minimizes the distributed input capacitance and yields optimum rise time.

d. Mount the Input Head of the Model 605 as close to the preparation as possible. The longer the lead the greater the capacitance to ground and, therefore, the greater the rise time. Longer leads will produce more electrostatic ac pickup too: also, increased cable length between Input Head and Power Module will increase rise time, and over 3 feet of cable between the Model 605 OUTPUT and the oscilloscope may increase rise time.

2-5. CAPACITANCE TUNING. Rise time can be easily checked and optimized with the Model 605.

a. To tune for the desired rise time, connect the microelectrode to the indifferent electrode by immersing the tip of the microelectrode into the bath, but not into the cell.

b. Apply a triangular voltage wave to the CAL Input on the Power Module (about 1000 cps is good). Adjust the amplitude of this wave to read between 100 and 200 millivolts at the Model 605 Output (one or two hundred millivolts is representative of the signal to be measured). A 5 picofarad capacitor in the Input Head, C103, and the resistance of the microelectrode form a differentiator to produce a square current pulse at the input of the Input Head.

c. Tune for optimum rise time by making capacitance adjustments using the Capacitance Adjust Controls.

1. There are two considerations to be taken into account before determining what optimum tuning is.

a) Decreasing the rise time of the amplifier by tuning necessarily increases the amplifier noise. The acceptable noise level can only be determined by the magnitude of the signal being measured.

b) Rise time can be decreased by further neutralization but eventually overshoot and oscillation result. Excessive overshoot causes an erroneous reading for a fast impulse.

2. The Model 605 specified rise time (see Specifications, Table 1) can be achieved only under the following conditions.

a) Set the FINE CAP ADJ Control in the MAX Position (completely clockwise).

b) Achieve minimum distributed capacitance at the input by connecting a 10 or 22 megohm resistor with short leads from the input to the indifferent electrode.

c) Adjust the Capacitance Control on the Input Head for minimum rise time.

d. To make intracellular potential measurements after tuning for the optimum rise time, turn off the signal generator,* insert the tip of the microelectrode into the cell and take readings. In like manner, tuning can be achieved after a measurement by taking the tip of the microelectrode out of the cell while leaving it immersed in the bath, applying the calibration signal and tuning.

2-6. MICROELECTRODE RESISTANCE MEASUREMENT.

a. To determine the resistance of the microelectrode, first connect a known resistor of approximately 10 megohms between the input and the indifferent electrode. Apply a triangular wave to the CAL Receptacle. Choose a convenient wave amplitude and do not change it. Observe the magnitude of the square wave at the OUTPUT Receptacle of the Model 605. Repeat this procedure with a few other resistors with values of approximately 20, 50 or perhaps 100 megohms.

b. Next, connect the microelectrode to the Input Receptacle on the Input Head and short the microelectrode to the indifferent electrode by immersing the tip of the microelectrode into the bath, but not into the cell.

c. Do not change the amplitude of the applied triangular wave. Observe the magnitude of the square wave at the OUTPUT Receptacle of the Model 605 and compare the amplitude of this output with the amplitudes of the outputs of the known resistors. Determine the resistance of the microelectrode by interpolation.

d. To make intracellular potential measurements upon determining the resistance of the microelectrode, turn off the signal generator,* insert the tip of the microelectrode into the cell and take readings.

2-7. DRIFT, GRID CURRENT AND RINGING.

a. Drift is an inherent property of all electrometer tubes. The Model 605 uses an electrometer tube, V101, at the input and has the expected drift characteristic. The Model 605, however, must be warmed-up for at least one hour before the drift specification can be met. The drift of the Electrometer is cumulative, after the proper warm-up, and becomes moderately constant and quite predictable. However, a severe overload at the input, in the range of 20 to 100 volts, will cause increased drift for several minutes.

b. The Model 605 must be warmed-up for a short period, much less than an hour, before grid current specification is realized. An overload between 20 and 400 volts at the input will temporarily increase the grid current. The grid current after an overload or just when the instrument is turned on will generally be about 10^{-12} ampere.

c. Ringing at about 5 kc at up to 5 mv will occur in the electrometer tube when it is shocked. This ringing will subside after one or two minutes. However, the normal intracellular setup should be shock free because of the delicate microelectrode. Therefore, there should be no shock induced upon the Model 605 under normal conditions.

* Do not disconnect the CAL Cable from the Power Module. This will change the input capacitance. If it is necessary to remove the signal generator, then disconnect the CAL Cable from the generator and short that end. This will preserve the capacitance adjustment.

SECTION 3. CIRCUIT DESCRIPTION

3-1. GENERAL. The Keithley Model 605 is a negative capacitance electrometer. A variable capacitor is applied from the output of the amplifier to the input to neutralize the input capacitance and improve the signal rise time. The Input Head of the Model 605 contains a three-stage amplifier and the capacitive feedback networks. Within the Power Module is the power supply of the instrument, the zero control network and the output divider resistors which stabilize the amplifier gain to +2.

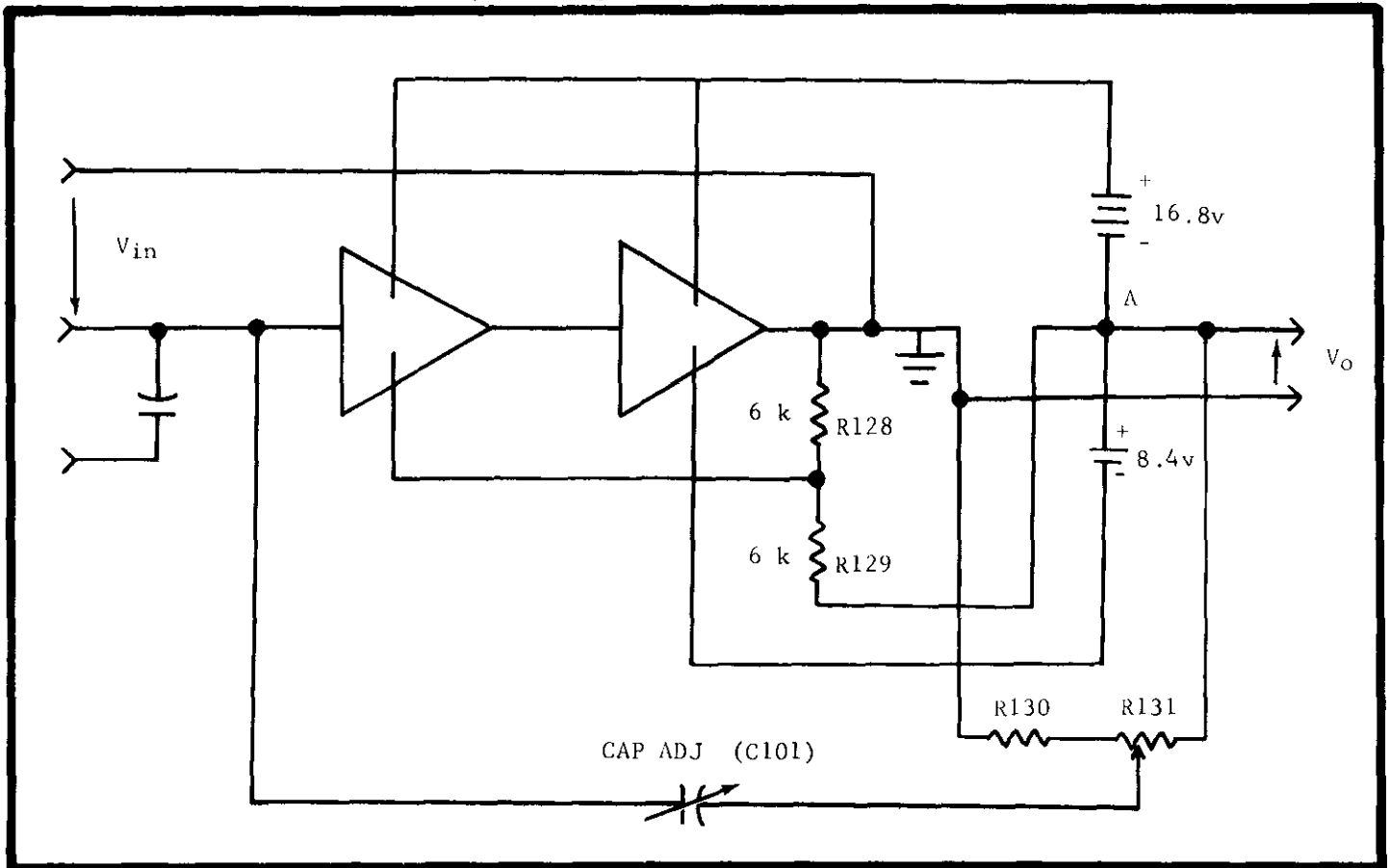

FIGURE 4. Model 605 Block Diagram.

3-2. INPUT HEAD.

a. The amplifier is a three-stage amplifier that employs positive feedback to achieve optimum signal rise time and negative feedback to obtain +2 gain stability.

b. A fraction of the output stage of the amplifier drives the cathode of the input stage, electrometer tube V101.

c. The output of Tube V101 drives the differential amplifier stage, transistors Q101 and Q102, for amplification.

d. The output of the differential amplifier, in turn, drives the emitter-follower output stage which is a bridge network composed of transistor Q103 and a floating power supply, B104, B105 and B106.

e. Positive capacitive feedback, used to neutralize input capacitance, is fed through the variable piston trimmer, C101, to the input of tube V101. The other end of the trimmer is connected to a variable output divider, resistors R130 and R131, to achieve a FINE CAPACITANCE ADJUSTMENT.

f. The potentiometer, R103, adjusts the frequency characteristics of the amplifier.

3-3. POWER MODULE.

a. The output divider resistors R128 and R129, which are 6 kilohm resistors, fix the gain of the amplifier at +2. The gain of the amplifier is determined by the equation:

$$V_{out} = V_{in} \left(\frac{R128 + R129}{R129} \right) \quad \text{equation 1}$$

Where V_{out} is the output voltage in volts;

V_{in} is the input voltage in volts;

and R128 and R129 are the divider resistors in ohms.

Since resistors R128 and R129 are both 6 kilohms, the equation becomes:

$$V_{out} = V_{in} \left(\frac{6 \text{ k}\Omega + 6 \text{ k}\Omega}{6 \text{ k}\Omega} \right) = 2V_{in},$$

and the gain is +2.

b. The ZERO Adjust Potentiometer, R114, and the Coarse Zero Adjust, P102, adjust the dc voltage of the screen grid for tube V101. This control fixes the tube operating points.

c. Batteries B102 and B103 supply the power to the Coarse Zero Control P102, which, in turn, determines the voltage at the screen grid of tube V101. Battery B101 supplies filament power to V101.

SECTION 4. MAINTENANCE

4-1. GENERAL.

a. Section 4 contains the maintenance, troubleshooting and calibration procedures for the Model 605 Negative Capacitance Electrometer. It is recommended that these procedures be followed as close as possible to maintain the accuracy of the instrument.

b. The Model 605 requires no periodic maintenance beyond the normal care required of high-quality electronic equipment.

4-2. PARTS REPLACEMENT.

a. The Replaceable Parts List in Section 6 describes the electrical components of the Model 605. Replace components only as necessary. Use only reliable replacements which meet the specifications.

b. The electrometer tube, V101, is specially selected and aged; order only from Keithley Instruments, Inc. In normal use, it should not need replacement before 10,000 hours of operation. It can be checked only by replacement. A standard 5886 tube can be used in an emergency, but the drift, noise and grid current specifications may not be met. When replacing the electrometer tube, do not touch the glass base where the leads emerge. Increased leakage will result from any contamination.

c. Transistors Q101 and Q102 are matched for low noise; order only in pairs from Keithley Instruments, Inc. When ordering, Q101 is supplied with an identifying paint dot.

4-3. SPECIAL MAINTENANCE PRECAUTIONS.

a. Salt Solution Handling.

1. Special care should be taken in handling the salt solutions so that they will not contaminate the Electrometer.

2. The Model 605 has a tight-fitting chrome plated Input Head that should preserve its beauty for years to come. Spilling salt solutions on the Input Head should not be harmful to the circuitry inside. However, the Head is not water proof, and immersing it in a solution may ruin the circuitry.

TABLE 4. Troubleshooting and Calibrating Equipment.

Equipment Recommended for Model 605 Troubleshooting and Calibration. Use these instruments or their equivalents.

Instrument	Use
dc voltmeter, with minimum 100-megohm input resistance, 10% accuracy, range from 1 volt to 300 volts	Circuit checking
Tektronix Type 502A Oscilloscope	Calibration

3. The Power Module is not sealed or chrome plated but since it can be removed from the proximity of the experiment, it should not receive a large dose of splashing and contamination from the salt solutions. It should, however, survive the spills and splashes that it does receive.

b. Input Circuitry.

1. The high impedance input circuitry should receive special care.

2. Do not touch or contaminate the Teflon insulation, the polystyrene capacitor (C103), the glass piston capacitor (C101), or the electrometer tube (V101) in any way. Contamination will destroy the offset current specification.

3. If a component becomes contaminated it may be cleaned with a cotton swab and alcohol. However, if a component or the Teflon insulation of a connector becomes badly contaminated from the salt solution, replacement may be necessary.

c. Batteries.

1. Maintain the batteries in good condition.

2. To check the batteries, turn the POWER Switch to off (red dot not visible) and check the voltage across each battery with a voltmeter.

3. The mercury batteries, as used in the Model 605, have a very discernible aging characteristic (See Figure 5). During the useful life of the battery a steady voltage exists between the terminals of the battery. When the end of the cells useful life has been reached a very rapid voltage drop occurs, and the battery must be replaced.

4. Low battery voltage is characterized by excessive output drift, inability to zero the output, erratic spikes in the output of the Model 605, poor rise time of the amplifier, or less than ± 2 volts dynamic range at the output.

d. Coarse Zero Control.

1. If the zero drifts out of range of the ZERO Control on the front panel, it can be brought back into range of the ZERO Control by adjusting the Coarse Zero Divider inside the Power Module.

2. To adjust the Coarse Zero Divider, move the two connectors, P102 (Figure 6), up or down one position. Maintain one position between the connectors at all times unless a greater zero suppression range with less zero resolution is desired. The lesser the number of spaces between the connectors P102, the finer the zero resolution. The greater the number of spaces between the connectors P102, the wider the zero range. Increasing the spaces, however, decreases the life of batteries B102 and B103.

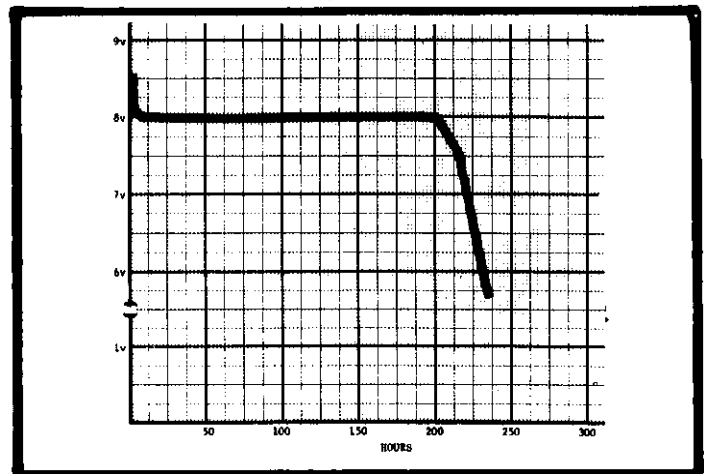

FIGURE 5. Battery Life for Model 605.

TABLE 5. Model 605 Troubleshooting

Difficulty	Probable Cause	Solution
Output will not zero	Batteries failing	Check per paragraph 4-3 and replace faulty batteries
	Coarse Zero Divider is not properly positioned	Adjust per paragraph 4-6
Excessive zero drift	Batteries failing	Check per paragraph 4-3 and replace faulty batteries
	Defective electrometer tube	Check V101 and replace if faulty
Excessive grid current	Excessive humidity or defective electrometer tube	Check V101 and replace if faulty
	Contaminated insulation	Clean with cotton swab and alcohol
Excessive microphonics (more than 10 mv at the input)	Defective electrometer tube	Check V101 and replace if faulty
Slow rise time	Maladjusted roll-off network	Adjust per paragraph 4-6
	Excessive distributed capacitance on the input lead	See paragraph 2-5
	Batteries failing	Check per paragraph 4-3 and replace faulty batteries

4-4. TROUBLESHOOTING.

a. The procedures which follow give instructions for repairing troubles which might occur in the Model 605. Use the procedures outlined and use only specified replacement parts. Table 4 lists equipment recommended for troubleshooting. If the trouble cannot be readily located or repaired, Keithley Instruments, Inc., can service the instrument at its complete service facilities. Contact your nearest representative.

b. Table 5 contains the more common troubles which might occur. If the repairs indicated in the table do not clear up the trouble, find the difficulty through a circuit-by-circuit check as given in paragraph 4-5. Refer to the circuit description in Section 3 to find the more critical components and to determine their function in the circuit. The complete circuit schematic, 20387C, is found in Section 6.

4-5. PROCEDURES TO GUIDE TROUBLESHOOTING.

- a. If the instrument will not work properly, check the condition of the batteries (paragraph 4-3). If these are found to be satisfactory, use the following procedures to isolate the trouble.
- b. Disconnect all wires and cables from the Input Head and the Power Module. Connect the Input Head to the Power Module with the supplied nine-lead, shielded cord.
- c. Disconnect resistor R128 and short out resistor R129. This removes the negative feedback, which stabilizes the fixed gain of 2, and produces an open loop amplifier with a gain around 2000. Such a system enables the user to better check the circuit voltages.
- d. The point between batteries B105 and B106 (point A, Figure 6) is now ground.
- e. Short the input to ground, point A, by running a wire from the Input on the Input Head to the OUTPUT on the Power Module. Point A, ground, is connected to the OUTPUT.
- f. Zero the output. The output is taken from the emitter of transistor Q103 (which is connected to the chassis) to point A, which is ground and is connected to the OUTPUT.
 1. Monitor the output signal with a dc voltmeter that has a minimum input resistance of 100 megohms. Connect the ground of the voltmeter to the OUTPUT of the Model 605 and connect the high side of the voltmeter to the case of the Model 605.
 2. Zero the output with the ZERO Control.
- g. If the output can be zeroed, check voltages at various points in the circuit with the dc voltmeter. The obtained values should be within $\pm 10\%$ of the typical voltages shown on the schematic. Replace components as necessary.
- h. If the output cannot be zeroed, adjust the ZERO Control to cause a signal and trace this signal through the amplifier. Monitor this signal first at the plate of tube V101 with the dc voltmeter connected as above. If a response to the ZERO Control does not occur on the plate of V101, then the tube, its biasing resistors or the next transistor, Q101, is defective and should be replaced.
- i. Next, monitor the signal at the collectors of the transistors Q101 and Q102. If no signal can be obtained, then the transistors, their biasing resistors or the next transistor, Q103, is faulty and should be replaced.
- j. Finally, monitor the signal at the emitter of transistor Q103. If no signal can be obtained, then this transistor or its biasing resistors are faulty and should be replaced.
- k. Upon completion of troubleshooting the Model 605, replace the negative feedback resistor, R128, remove the short from resistor R129 and remove the short between the input and point A. The instrument should now work fine.

4-6. CALIBRATION.

- a. The following procedures are recommended for calibrating and adjusting the Model 605. Use the equipment recommended in Table 4. If the proper facilities are not available or if difficulty is encountered, contact Keithley Instruments, Inc., or its representative to arrange for factory calibration.

- b. Short the input to ground.
- c. Zero the output by setting the Coarse Zero Divider, P102 (Figure 8), to the proper position. The proper position may be found by the method of trial and error (See also paragraph 4-3d). Always keep one vacant terminal between the two connectors. Final adjustment should be made with the front panel control.
- d. Apply a triangular wave through the CAL Receptacle on the Power Module (See paragraph 2-3). Connect a 22 megohm resistor with short leads between the Input and ground.
- e. Turn the FINE CAP ADJ Control to the MAX Position (completely clockwise).
- f. Adjust the Coarse Capacitance Adjust Control on the Input Head for minimum rise time.
- g. Now adjust the roll-off potentiometer, R103, for minimum rise time. By adjusting both controls, i.e., the roll-off potentiometer and the Coarse Capacitance Adjust Control, an optimum rise time is achieved.

NOTE

Replacing the Input Head cover changes the input capacitance and may cause misadjustment. A small metal plate with a hole in it above potentiometer R103 is useful for this adjustment.

- h. Upon completion of these adjustments, the Model 605 is calibrated and should meet all specifications

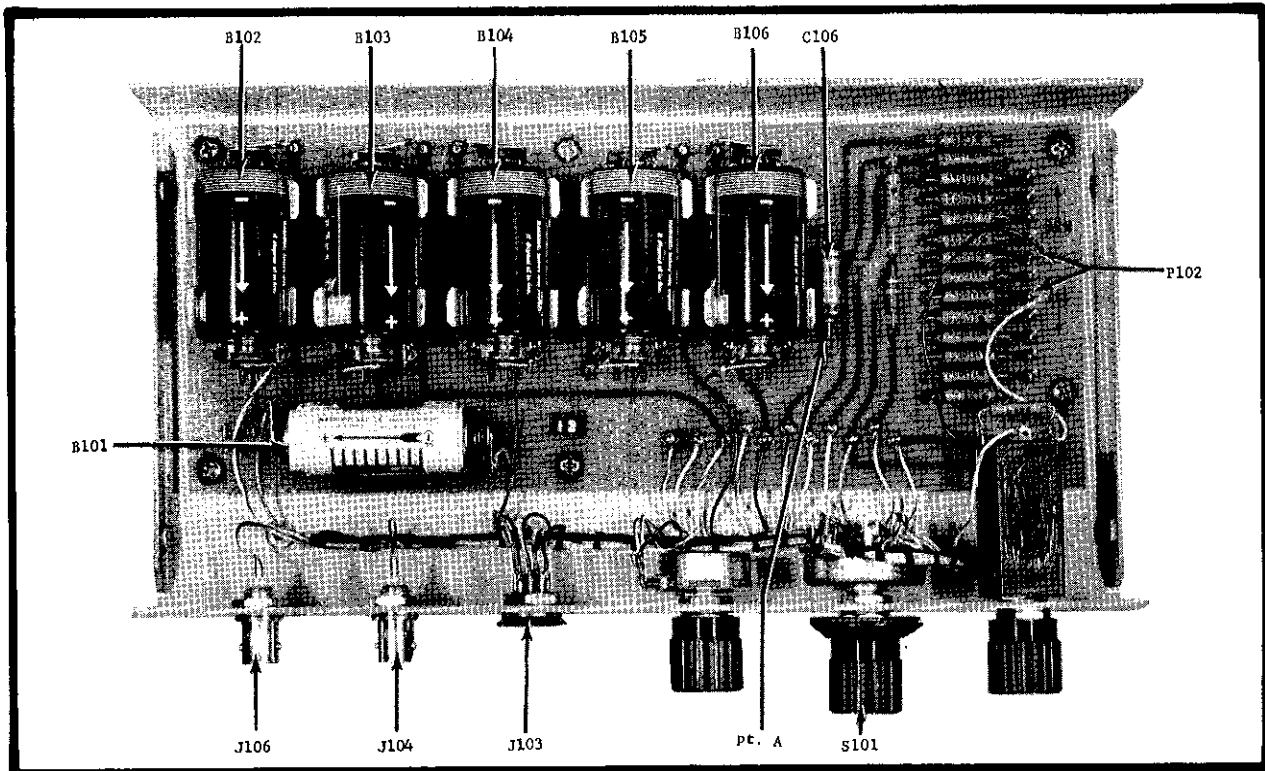

FIGURE 6. Battery, Connector, Switch and Terminal Locations Within the Power Module. Resistors are shown in Figure 7.

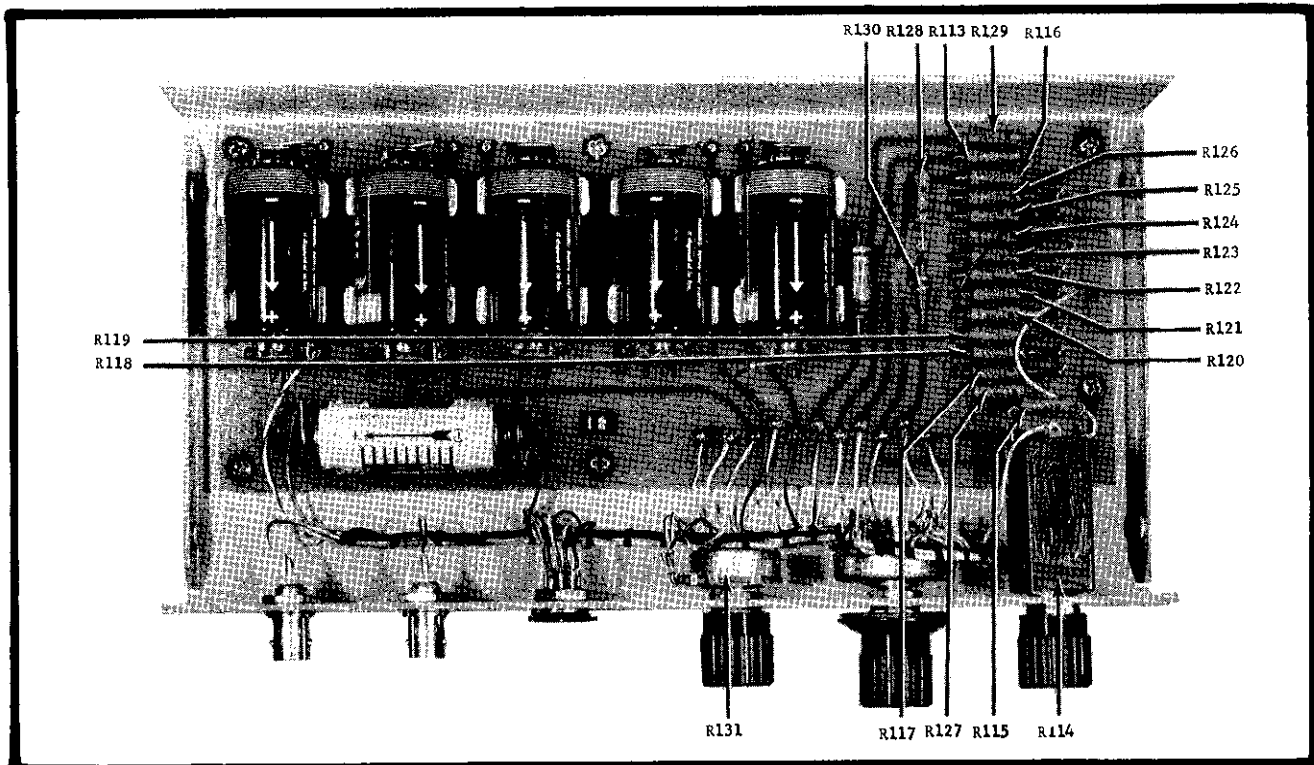

FIGURE 7. Resistor Locations Within the Power Module. Other components are shown in Figure 6.

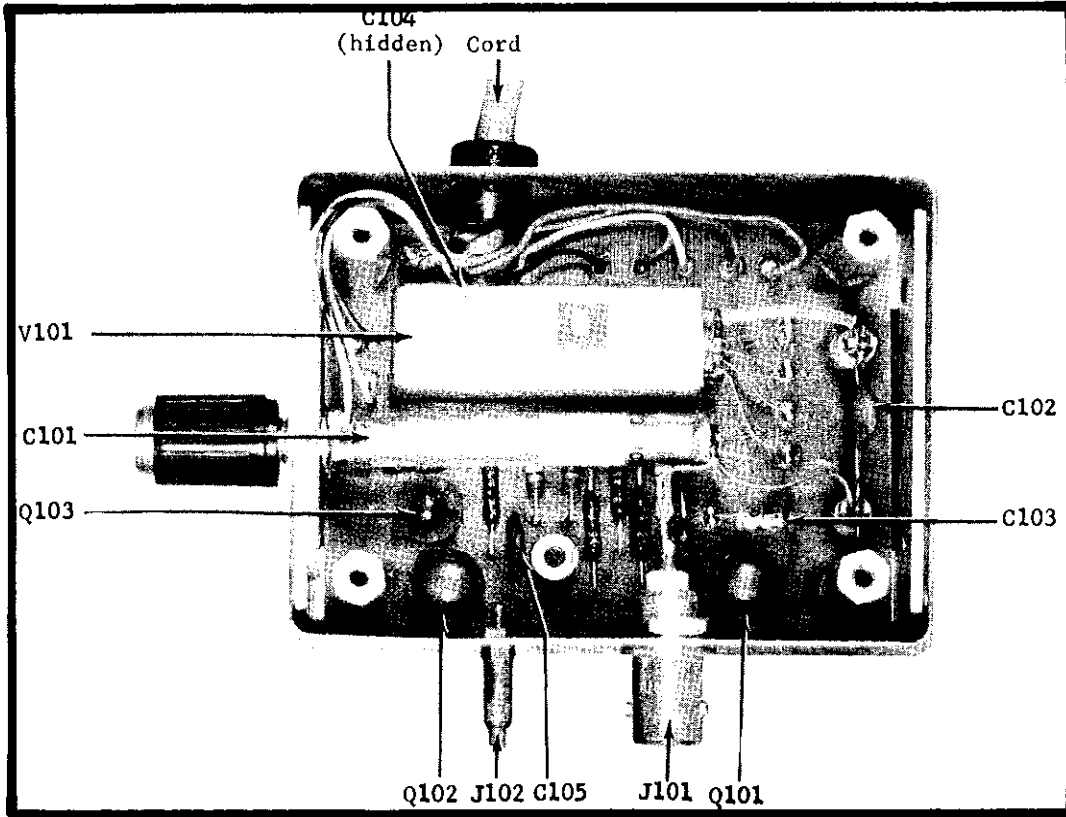

FIGURE 8. Capacitor, Connector, Transistor and Tube Locations Within the Input Head. Resistor Locations are shown in Figure 9.

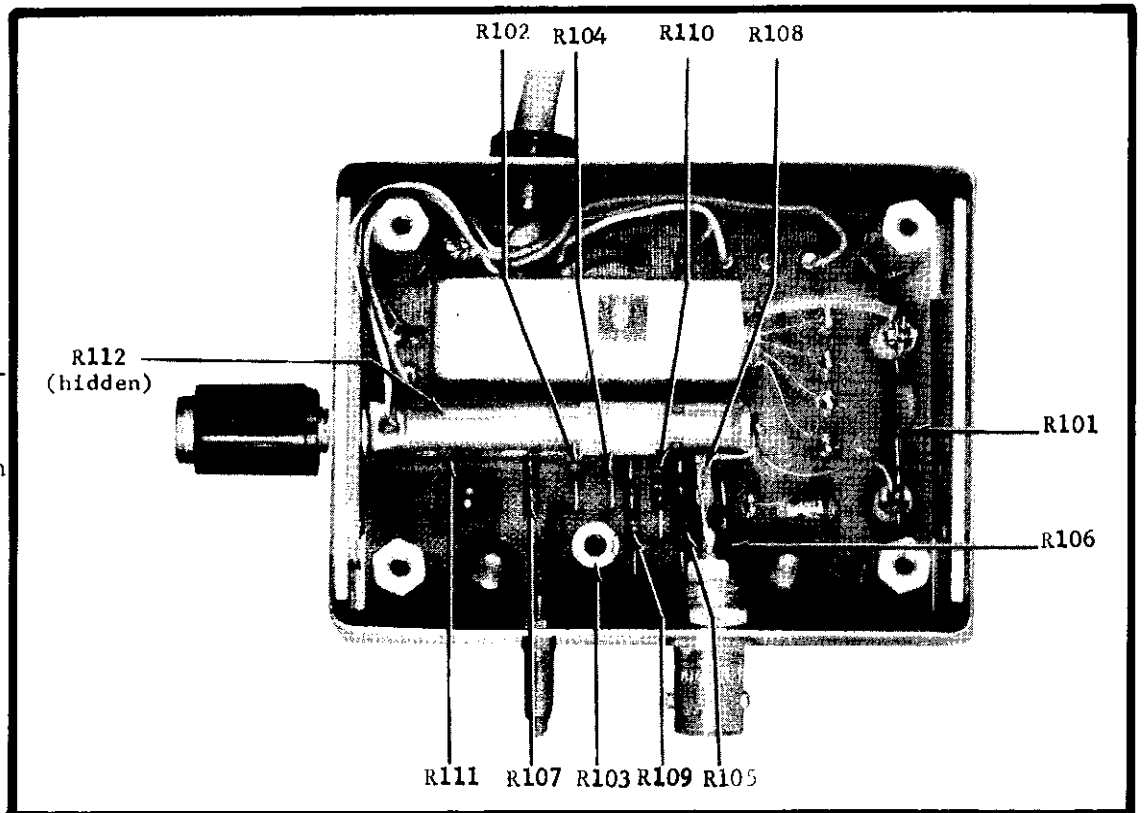

FIGURE 9. Resistor Locations Within the Input Head. Other component locations are shown in Figure 8.

SECTION 5. ACCESSORIES

5-1. MODEL 6051 MOUNTING BRACKET.

a. The Keithley Model 6051 Mounting Bracket is a supplied accessory that, when attached to the base of the Model 605 Input Head, enables the Head to be supported by a standard laboratory ring stand and rod clamp.

b. To attach the Input Head to the Mounting Bracket, remove the four screws on the bottom of the Input Head. Place the four rubber feet between the Input Head and the Mounting Bracket. Fasten together using the four previously removed screws. (Refer to Figure 10.)

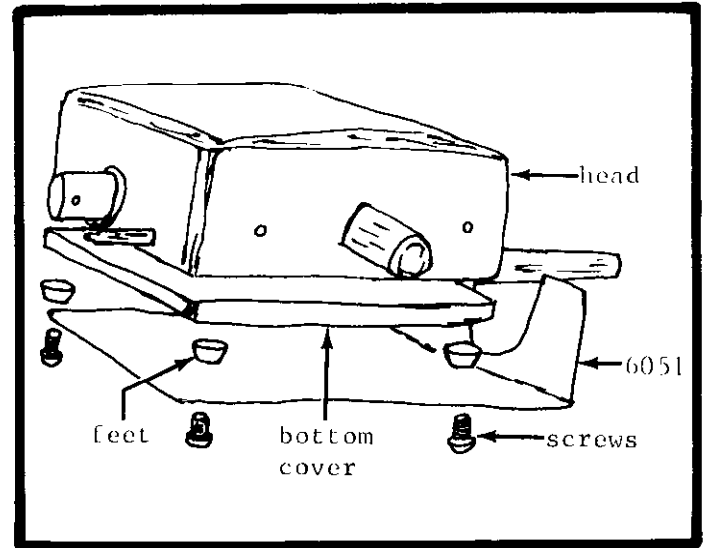

FIGURE 10. Keithley Model 605 Input Head and Model 6051 Mounting Bracket.

5-2. MODEL 6052 INTEGRATOR.

a. The Keithley Model 6052 Integrator is used to integrate square waves to supply a ramp function to the Model 605 CAL Receptacle for calibrating the Model 605 (See paragraph 2-3). Approximately 50 volts peak-to-peak is required at the input of the Model 6052. It has a male uhf input and a female uhf output.

b. To use the Model 6052 Integrator with the Model 605, attach the input of the Integrator to the calibration output of an oscilloscope or some other generating device. If the calibrator output uses a bnc connector, use a uhf-to-bnc adapter such as the Keithley part number CS-172 which has a male bnc and a female uhf. Connect the Integrator to the Model 605 CAL Receptacle. The CAL Receptacle on the Model 605 is a bnc receptacle.

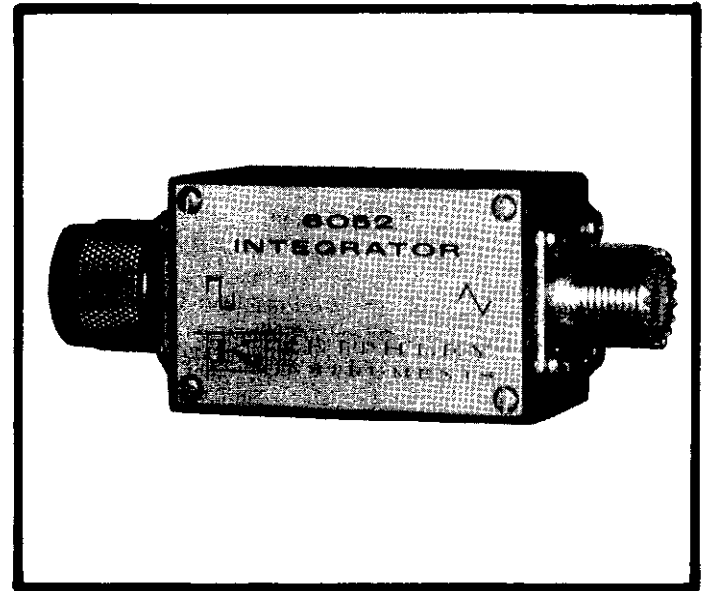

FIGURE 11. Keithley Model 6052 Integrator.

5-3. MODEL 6053 CABLE. The Keithley Model 6053 Cable is a 3-foot coaxial cable with a male uhf on one end and a male bnc on the other. The Cable is useful for connecting the female uhf output of the Model 6052 Integrator to the Model 605 CAL Receptacle, which is a bnc receptacle. The 6053 is also useful for output as well as calibrate.

SECTION 6. REPLACEABLE PARTS

6-1. REPLACEABLE PARTS LIST. The Replaceable Parts List describes the components of the Model 605 (and its accessories). The list gives the circuit designation, the part description, a suggested manufacturer, the manufacturer's part number and the Keithley Part Number. The last column indicates the figure picturing the part. The name and address of the manufacturers listed in the "Mfg. Code" column are in Table 6.

6-2. HOW TO ORDER PARTS.

a. For parts orders, include the instrument's model and serial number, the Keithley Part Number, the circuit designation and a description of the part. All structural parts and those parts coded for Keithley manufacture (80164) must be ordered through Keithley Instruments, Inc. or its representative. In ordering a part not listed in the Replaceable Parts List; completely describe the part, its function and its location.

b. Order parts through your nearest Keithley representative or the Sales Service Department, Keithley Instruments, Inc.

TABLE 6. Symbols and Abbreviations

amp	ampere	Mfg.	Manufacturer
		Mil. No.	Military Type Number
Cb	Carbon	MtF.	Metal Film
Cerd	Ceramic Disc		
Comp	Composition	Ω	ohm
DCb	Deposited Carbon	p	pico (10^{-12})
		Poly	Polystyrene
ETB	Electrolytic Tubular		
		Ref	Reference
f	farad	req'd	required
Fig	Figure		
		μ	micro (10^{-6})
GPT	Glass Piston Trimmer		
		v	volt
k	kilo (10^3)		
		w	watt
M or meg	Mega (10^6) or Megohm	WWVar	Wirewound Variable

MODEL 605 REPLACEABLE PARTS LIST

(Refer to Schematic Diagram 20387C for circuit designations)

BATTERIES

Circuit Desig.	Description	Mfg. Code	Mfg. Part No.	Keithley Part No.	Fig. Ref.
B101	1.34 volt Mercury Battery	61637	E12	BA-7	6
B102	8.4 volt Mercury Battery	72665	TR-286	BA-18	6
B103	8.4 volt Mercury Battery	72665	TR-286	BA-18	6
B104	8.4 volt Mercury Battery	72665	TR-286	BA-18	6
B105	8.4 volt Mercury Battery	72665	TR-286	BA-18	6
B106	8.4 volt Mercury Battery	72665	TR-286	BA-18	6

CAPACITORS

Circuit Desig.	Value	Rating	Type	Mfg. Code	Mfg. Part No.	Keithley Part No.	Fig. Ref.
C101	1-90 pf	1000 v	GPT	16509	TM90CE	C153-90P	8, 2
C102	.0047 μ f	600 v	Cerd	72982	ED-.0047	C22-.0047M	8
C103	5 pf	200 v	Poly	14167	E1013-1	C31-5P	8
C104	.0022 μ f	100 v	Poly	13934	E3FR-222-1-C	C152-.0022M	8
C105	33 pf	600 v	Cerd	72982	ED-33	C22-33P	8
C106	125 μ f	15 v	ETB	73445	C426	C3-125M	6

MISCELLANEOUS PARTS

Circuit Desig.	Description	Mfg. Code	Keithley Part No.	Fig. Ref.
---	Battery holder (Mfg. No. 2139)	94139	BH-16	
---	Battery holder, 5 req'd (Mfg. No. 2173)	94139	BH-21	
---	Battery holder retaining clip, 2 req'd (Mfg. No. 66)	94139	BH-23	
---	Battery holder retaining clip, 10 req'd (Mfg. No. 62)	94139	BH-22	
---	Cable clamp	80164	20354A	
J101	Input Receptacle, bnc (Mil. No. UG-1094/U)	02660	CS-15	8, 2
J102	Spring Lock ground post terminal	80164	TE-30	8, 2
J103	PROBE Receptacle (Mfg. No. 126-221)	02660	CS-81	6, 2
J104	CAL Receptacle, bnc (Mil. No. UG-1094/U)	02660	CS-15	6, 2
J105	Printed circuit contacts, 11 pin (Mfg. No. 02-011-113-6-200)	80164	CS-184	
J106	OUTPUT Receptacle, bnc (Mil. No. UG-1094/U)	02660	CS-15	6, 2

MISCELLANEOUS PARTS (Cont'd)

Circuit Desig.	Description	Mfg. Code	Keithley Part No.	Fig. Ref.
P101	Plug, mate of J103 (Mfg. No. 126-220)	02660	CS-82	2
P102	Contact for J105, 2 req'd (Mfg. No. 50-8017.0313)	80164	CS-185	6
S101	POWER Switch	80164	20313A	6, 2
---	Knob Assembly, Power Switch	80164	18393A	
---	FINE CAP ADJ Control (Mfg. Type 45)	71450	RP54-1K	2
---	Knob, Fine Cap Adj Control	80164	15644A	
---	ZERO Control (Mfg. No. 62JA)	12697	RP42-10K	2
---	Knob, Zero Control	80164	15461A	
---	Coarse Capacitance Adjust (Mfg. No. TM90CE)	16509	G153-90P	2
---	Knob, Coarse Capacitance Adjust	80164	KN-32	

RESISTORS

Circuit Desig.	Value	Rating	Type	Mfg. Code	Mfg. Part No.	Keithley Part No.	Fig. Ref.
R101	10 M Ω	10%, 1/4 w	Comp	01121	CB	R76-10M	9
R102	100 k Ω	1%, 1/8 w	MtF	07716	CEA	R88-100K	9
R103	20 k Ω	30%, 1/2 w	Cermet	73138	62P-R20K	RP55-20K	9
R104	*4.7 k Ω	10%, 1/4 w	Comp	01121	CB	R76-4.7K	9
R105	39.2 k Ω	1%, 1/8 w	MtF	07716	CEA	R88-39.2K	9
R106	11 k Ω	1%, 1/8 w	MtF	07716	CEA	R88-11K	9
R107	39.2 k Ω	1%, 1/8 w	MtF	07716	CEA	R88-39.2K	9
R108	100 k Ω	10%, 1/4 w	Comp	01121	CB	R76-100K	9
R109	49.9 k Ω	1%, 1/8 w	MtF	07716	CEA	R88-49.9K	9
R110	15 k Ω	1%, 1/8 w	MtF	07716	CEA	R88-15K	9
R111	8.06 k Ω	1%, 1/8 w	MtF	07716	CEA	R88-8.06K	9
R112	8.06 k Ω	1%, 1/8 w	MtF	07716	CEA	R88-8.06K	9
R113	1.667 k Ω	1%, 1/2 w	DCb	91637	DCF-1/2	R12-1.667K	7
R114	10 k Ω	5%, 2 w	WWVar	12697	625A	RP42-10K	7, 2
R115	6.8 k Ω	1%, 1/2 w	DCb	91637	DCF-1/2	R12-6.8K	7
R116	4.3 k Ω	1%, 1/2 w	DCb	91637	DCF-1/2	R12-4.3K	7
R117	500 Ω	1%, 1/2 w	DCb	91637	DCF-1/2	R12-500	
R118	500 Ω	1%, 1/2 w	DCb	91637	DCF-1/2	R12-500	7
R119	500 Ω	1%, 1/2 w	DCb	91637	DCF-1/2	R12-500	7
R120	500 Ω	1%, 1/2 w	DCb	91637	DCF-1/2	R12-500	7
R121	500 Ω	1%, 1/2 w	DCb	91637	DCF-1/2	R12-500	7
R122	500 Ω	1%, 1/2 w	DCb	91637	DCF-1/2	R12-500	7

* Nominal value, factory selected.

RESISTORS (Cont'd)

Circuit Desig.	Value	Rating	Type	Mfg. Code	Mfg. Part No.	Keithley Part No.	Fig. Ref.
R123	500 Ω	1%, 1/2 w	DCb	91637	DCF-1/2	R12-500	7
R124	500 Ω	1%, 1/2 w	DCb	91637	DCF-1/2	R12-500	7
R125	500 Ω	1%, 1/2 w	DCb	91637	DCF-1/2	R12-500	7
R126	500 Ω	1%, 1/2 w	DCb	91637	DCF-1/2	R12-500	7
R127	1.5 k Ω	1%, 1/2 w	DCb	91637	DCF-1/2	R12-1.5K	7
R128	6 k Ω	1%, 1/2 w	DCb	91637	DCF-1/2	R12-6K	7
R129	6 k Ω	1%, 1/2 w	DCb	91637	DCF-1/2	R12-6K	7
R130	22 k Ω	10%, 1/2 w	Comp	01121	EB	R1-22K	7
R131	1 k Ω	\pm 20%, 1/2 w	Cb	71450	TYPE-45	RP54-1K	7, 2

TRANSISTORS

Circuit Desig.	Number	Mfg. Code	Keithley Part No.	Fig. Ref.
Q101 **	S17638	80164	20996A	8
Q102 **	S17638	80164	20996A	8
Q103	2N3565	07263	TG-39	8

VACUUM TUBES

Circuit Desig.	Number	Mfg. Code	Keithley Part No.	Fig. Ref.
V101	5886-5X	80164	EV-5886-5X	8

** Q101 and Q102 are matched for low noise. Order only in pairs from Keithley. When ordering replacement parts, Q101 is supplied with identifying paint dot. Original parts contain no identifying mark.

TABLE 7. Manufacturers

Code List of Suggested Manufacturers. (Based on Federal Supply Code for Manufacturers, Cataloging Handbook H4-1).

01121	Allen-Bradley Corp. Milwaukee, Wis.	61637	Union Carbide Corp. New York, N. Y.
02660	Amphenol-Borg Electronics Corp. Broadview, Chicago, Illinois	72665	Mallory Battery Co. Cleveland, Ohio
07263	Fairchild Camera & Instru. Corp. Semiconductor Division Mountain View, Cal.	72699	General Instrument Corp. Newark, N. J.
07716	International Resistance Co. Burlington, Iowa	72982	Erie Technological Products, Inc. Erie, Pa.
11450	Challenge Machine Co., The North Wales, Pa.	73138	Helipot Division of Beckman Instruments, Inc. Fullerton, Calif.
12697	Clarostat Mfg. Co., Inc. Dover, N. H.	73445	Amperex Electronic Co. Division of North American Philips Co., Inc. Hicksville, N. Y.
13934	Midwec Corp. 600 Main Oshkosh, Nebr.	80164	Keithley Instruments, Inc. Cleveland, Ohio
14167	Efcon, Inc. Garden City, Long Island, N. Y.	91637	Dale Electronics, Inc. Columbus, Nebr.
16509	Voltronics, Inc. 7746 W. Addison Chicago, Ill.	94139	Keystone Electronics Co. 67-7th Ave. Newark, N. J.

REV	DATE	BY
A	12-16-67	VP
B	1-16-68	VP

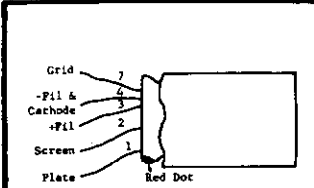
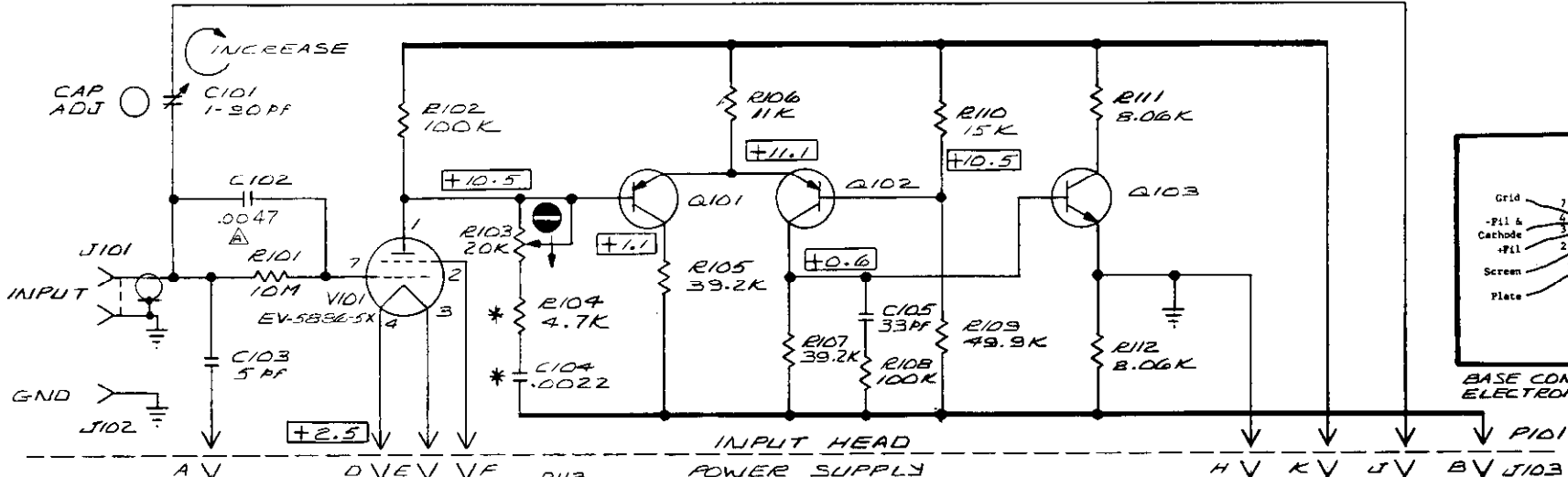

BASE CONNECTIONS FOR ELECTROMETER TUBE

NOTE:
ALL VOLTAGES ARE MEASURED WITH INPUT SHORTED, WITH OUTPUT ZEROED, AND C101 IN COUNTER CLOCK WISE POSITION.

- NOTES:**
- FRONT PANEL CONTROL
 - INTERNAL SCREWDRIVER ADJUSTMENT
 - K: 1000 OHMS
 - M: MEGOHMS
 - pf: PICOFARADS
 - ALL RESISTORS AND CAPACITORS ARE DESIGNATED IN OHMS AND MICROFARADS RESPECTIVELY, UNLESS OTHERWISE NOTED.
 - ↑: C.W. ROTATION
 - *: NOMINAL VALUE ADJUSTED AT FACTORY
 - : VOLTAGE RANGE (TYP)

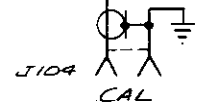
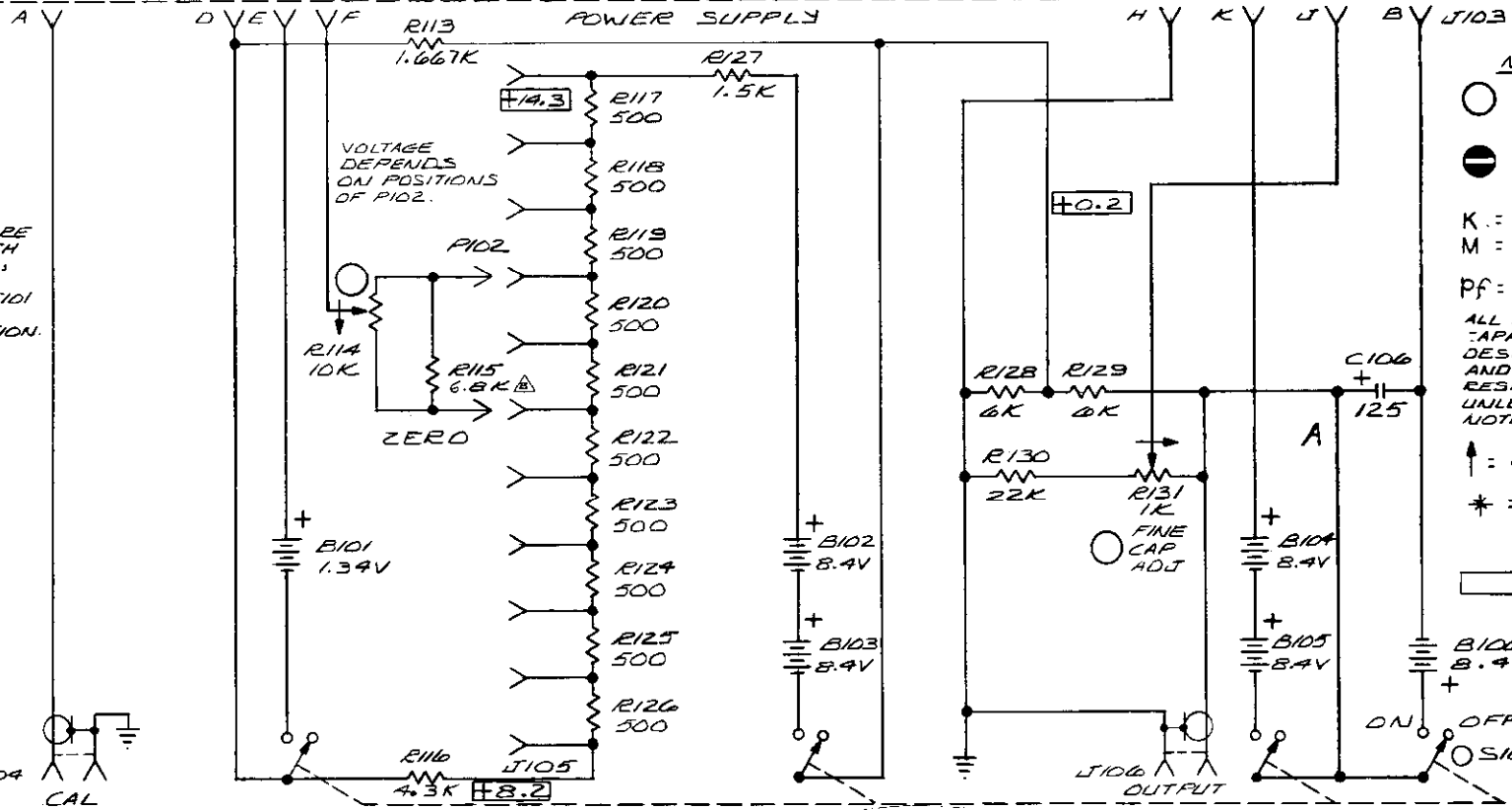

HIGHEST REF DESIGNATION				DESIGNATIONS NOT USED			
R131	C106	Q103	J106				
B106	S101	P102	V101				

DRW: GCH/HA	DATE: 3-24-67
CHK: MK	DATE: 1-6-67
ENL: APP	DATE: 1-6-67
REL: J	DATE: 1-1-67
ISS: J	DATE: 1-11-67



TITLE	SCHMATIC-605
PART NUMBER	20387C

REPAIR AND CALIBRATION FORM

For repair or calibration, please fill out this form and return it with your instrument to:
 Sales Service Department
 Keithley Instruments, Inc.
 28775 Aurora Road
 Cleveland, Ohio 44139

R-
 Do not write in this space.

User's Name _____ Telephone _____ Ext. _____
 Company _____ Address _____
 Division _____ City _____ State _____ Zip _____
 Date _____ Model No. _____ Serial No. _____

1. Reason for Return
 Repair and Recalibration
 Recalibration only (No report, except as specified in item 4 on reverse)*
 *If repairs are necessary to meet specifications, they will be in addition to the calibration.
2. Calibration Report Desired
 Report of Calibration Certified Traceable to N.B.S.
 Calibration Report
 Certificate of Compliance
 None
 (for details, see reverse side of this form)

3. To help repair the instrument, briefly describe the problem: _____

4. Is the problem Constant Intermittant
 Under what conditions does the problem occur:
 a) Control setting _____

 b) Approx. Temperature _____ °F
 c) Approx. Temperature variation ± _____ °F
 d) Approx. Humidity (high, medium, low) _____
 e) Line voltage _____
 f) Other (such as line transients, line variations, etc.) _____

5. Please draw a block diagram of the system using the Keithley. List any other pertinent data which can help in the repair. Include charts or other data if available.
 Signal Source _____
 Source Impedance _____
 Readout Device:
 Recorder
 Oscilloscope
 Other
 None
 Lengths & Types of Connecting Cables _____

6. What repairs or modifications have been made on this instrument which are not on file with the Keithley Repair Department? _____

7. Please enclose any other pertinent data and charts which you feel might help the Repair and Calibration Department

 Signature Title

CALIBRATIONS AVAILABLE AT KEITHLEY INSTRUMENTS.

Listed and defined below are the four types of calibrations and their associated report formats which are presently available at Keithley Instruments. They fall into the following categories:

1. Report of Calibration Certified Traceable to the National Bureau of Standards
2. Calibration Report
3. Certificate of Compliance
4. Recalibration

All calibration and certification performed by Keithley Instruments is in accord with MIL-C-45662A.

Prices shown below are in addition to repair charges for any work necessary to place a customer's unit into first class condition prior to the calibration.

1. Report of Calibration Certified Traceable to the National Bureau of Standards.

This is a completely documented report, including all basic errors or deviations from nominal settings on appropriate ranges, terminals, dials, etc. Work is performed using the primary standards of the company with secondary transfers kept to a minimum. The NBS test numbers for the latest recalibration of the primary standards are furnished.

By definition, the above is performed in our Standards Laboratory so that random operator induced error is minimized and maximum protection to the equipment used is maintained.

This type of calibration is not recommended for instruments with a basic inaccuracy of 1% or greater. The precision involved in this report makes it uneconomical for such instruments. The Calibration Report listed below (No. 2) would be better suited in this case.

As of 12/1/67 the Report of Calibration Certified Traceable to the National Bureau of Standards is available on the following instruments at the prices listed:

Model 140	\$.325	Model 5155 (Complete Set) . . .	\$265
Model 260	\$.220	Model 5155-10 ⁸	\$ 45
Model 261	\$.280	Model 5155-10 ⁹	\$ 45
Model 515	\$.520	Model 5155-10 ¹⁰	\$ 45
Model 630	\$.250	Model 5155-10 ¹¹	\$ 55
Model 660A	\$.200	Model 5155-10 ¹²	\$ 55
Model 662	\$.250	Model 5155-10 ¹³	\$ 75

2. Calibration Report.

This report shows only the cardinal range, terminal, dial, etc. errors as determined by production calibration equipment and personnel. The production equipment is maintained traceable by transfer techniques against the primary standards maintained by the company. We attest to this fact and list basic deviations from nominal but the conditions of calibration are not as precisely controlled as the previous report nor are NBS test numbers supplied.

This report is available for any instrument in our line. As of December 1, 1967, only the following price has been established for this report:

Model 261 \$50
Prices for other units can be estimated upon request.

3. Certificate of Compliance.

This is merely a restatement of the basic guarantee that the instrument was calibrated on equipment that is maintained by our standards personnel against primary standards. No report is issued.

This Certificate of Compliance is available at no charge for any instrument with the exception of the Model 261.

A newly purchased Model 261 or one returned for repair or recalibration is automatically supplied with a Calibration Report (as described in (2) above). The nature of this instrument makes it necessary to complete this report to ascertain specified accuracy. This Calibration Report is forwarded to the customer with the instrument. The \$50 charge is incorporated as part of the normal calibration charge of the Model 261.

4. Recalibration.

This is a recalibration of the instrument according to our factory calibration procedures. The prices for this as of December 1, 1967 are as follows:

Model 260	\$75	(No report supplied. A Certificate of Compliance can be had at no charge if requested).
Model 261	\$50	(Calibration Report as described in (2) above is supplied. See (3) for explanation).

All other instruments are on a time and material basis for the particular unit involved.