

K4XL's **BAMA**

This manual is provided **FREE OF CHARGE** from the "BoatAnchor Manual Archive" as a service to the Boatanchor community.

It was uploaded by someone who wanted to help you repair and maintain your equipment.

If you paid anyone other than BAMA for this manual, you paid someone who is making a profit from the free labor of others without asking their permission.

You may pass on copies of this manual to anyone who needs it. But do it without charge.

Thousands of files are available without charge from BAMA. Visit us at <http://bama.sbc.edu>

INSTRUCTION MANUAL

Serial Number _____

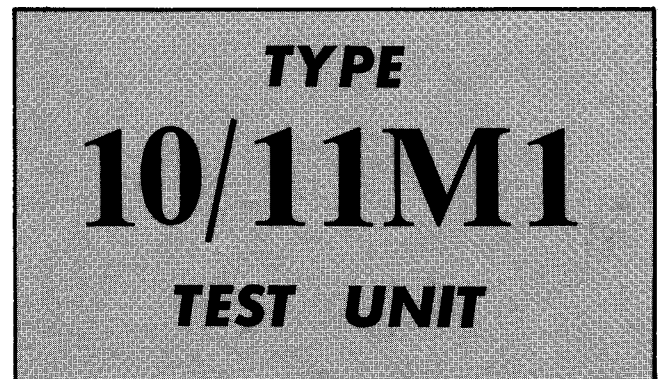

Tektronix, Inc.

S.W. Millikan Way • P. O. Box 500 • Beaverton, Oregon • Phone MI 4-0161 • Cables: Tektronix

Tektronix International A.G.

Terrassenweg 1A • Zug, Switzerland • PH. 042-49192 • Cable: Tekintag, Zug Switzerland • Telex 53.574



WARRANTY

All Tektronix instruments are warranted against defective materials and workmanship for one year. Tektronix transformers, manufactured in our own plant, are warranted for the life of the instrument.

Any questions with respect to the warranty mentioned above should be taken up with your Tektronix Field Engineer.

Tektronix repair and replacement-part service is geared directly to the field, therefore all requests for repairs and replacement parts should be directed to the Tektronix Field Office or Representative in your area. This procedure will assure you the fastest possible service. Please include the instrument Type and Serial number with all requests for parts or service.

Specifications and price change privileges reserved.

Copyright © 1964 by Tektronix, Inc., Beaverton, Oregon. Printed in the United States of America. All rights reserved. Contents of this publication may not be reproduced in any form without permission of the copyright owner.



CONTENTS

Warranty

- Section 1 Characteristics
- Section 2 Operating Instructions
- Section 3 Circuit Description
- Section 4 Maintenance and Calibration
- Section 5 Parts List and Diagrams

A list of abbreviations and symbols used in this manual will be found on page 5-1. Change information, if any is located at the rear of the manual.

TYPE 10/11M1 TEST UNIT

PULSE AMPLITUDE RATE
LOW OFF HIGH

6.3V AC AT CONNECTOR

POSITION

VERTICAL

DC CALIBRATE CM +3 TIME MARK + PULSE POLARITY -3 CM -

TIME MARK IN

ATTEN

HORIZ CAL

LOAD
PUSH TO SWITCH TO FULL
FULL HALF ZERO

CAUTION REMOVE OTHER PLUG-IN

SOURCE

RIPPLE
GND
DC ERROR

+100 V
+15 V
-15 V
-75 V

SERIAL OUTPUT

CAL WITH ZERO LOAD 5mV ±.1%

TEKTRONIX, INC., PORTLAND, OREGON, U. S. A.

SECTION 1

CHARACTERISTICS

General Description

The Type 10/11M1 Test Unit is a single-unit calibration aid for the Type 647 or Type RM647 Oscilloscope. The unit is designed to calibrate and standardize both the vertical and horizontal circuitry of the Type 647. The Type 10/11M1 aids in setting the oscilloscope: (1) power supply voltages, (2) horizontal amplifier gain, (3) vertical amplifier gain, and (4) vertical amplifier transient response. The 10/11M1 aids in checking: (1) regulation of the power supplies at different load conditions, and (2) power supply ripple. In addition, an external time-mark signal may be applied to the Type 10/11M1 for calibrating or checking the sweep rates of the time-base unit used with the Type 647.

Specifications

| | |
|--------------------------------|--|
| VERTICAL DC CALIBRATE Accuracy | $\pm 0.7\%$ |
| HORIZ CAL Accuracy | $\pm 0.3\%$ |
| Pulser Risetime | Nominally 3 nsec |
| Pulser Repetition Rates | 2.5 \pm 1 cps, 500 \pm 100 cps, 65 \pm 15 kc, and 600 \pm 150 kc |
| Pulser Amplitude | Variable, 0-8 cm |
| Flatness | $\pm 0.5\%$ after first 5 nsec |

| | |
|---------------------------------|---|
| Ringing | Less than 2% peak-to-peak (at frequencies above 300 mc) |
| TIME MARK INPUT Sensitivity | 100 mv/cm, $\pm 25\%$ |
| TIME MARK INPUT Bandwidth | Typically 3-db down below 7 kc and above 27 mc |
| TIME MARK INPUT Maximum Voltage | 100 volts |
| POSITION Control Range | At least ± 3 cm |
| DC ERROR Sensitivity | 5 mv per 0.1% error |
| DC ERROR Accuracy | $\pm 0.25\%$ absolute |
| Mechanical | Aluminum alloy chassis. Dimensions (overall): 14 $\frac{1}{2}$ " (L) \times 6 $\frac{1}{4}$ " (H) \times 4 $\frac{1}{4}$ " (W). Weight: Approx. 4 lbs. 10 ozs. |
| Environmental | Meets all non-operating environmental specifications of the Type 647 Oscilloscope. Calibration accuracy specifications apply within a temperature range of 15° to 35°C. |

SECTION 2

OPERATING INSTRUCTIONS

FUNCTION OF FRONT-PANEL CONTROLS AND CONNECTORS

| | | | |
|------------------------|--|--------------|---|
| PULSE AMPLITUDE | Control for adjusting pulse height when the VERTICAL switch is set to one of the PULSE POLARITY positions. | TIME MARK IN | Connector for applying an external time-mark signal when the VERTICAL/HORIZ CAL switch is set to TIME MARK. |
| PULSE RATE | A five-position switch concentric with the PULSE AMPLITUDE control. Sets the repetition rate of the pulse when the VERTICAL switch is set to one of the PULSE POLARITY positions. The pulser is turned off when the switch is set to OFF. | ATTEN | Variable attenuator for the signal applied to the TIME MARK IN connector. |
| 6.3V AC AT CONNECTOR | Lamp that lights to indicate the presence of 6.3V AC voltage at interconnecting plug. | LOAD | Three-position switch that selects the amount of loading on the power supply of the oscilloscope. |
| POSITION | Vertically positions the display when the plug-in unit is in the vertical opening of the oscilloscope and the VERTICAL switch is set to either TIME MARK or the PULSE POLARITY positions. The POSITION control has no effect when the VERTICAL switch is set to any other positions or when the Type 10/11M1 is in the horizontal plug-in compartment. | SOURCE | Two switches that determine the signal information appearing at the OUTPUT connector. The voltage SOURCE switch selects the desired power supply voltage of the oscilloscope. The other SOURCE switch determines what check may be made on a given supply voltage. In the RIPPLE position, the selected supply voltage is ac coupled to the OUTPUT connector. This blocks the dc component of the supply and allows only the ac or ripple voltage to appear at the OUTPUT connector. The GND position gives a convenient ground-reference without disconnecting and grounding the monitoring oscilloscope. The DC ERROR position compares the selected power supply voltage to an accurate reference voltage and couples the difference to the OUTPUT connector. A zero volt reading at the OUTPUT connector indicates that the power supply voltage is correct. A voltage reading at the OUTPUT connector indicates the power supply is incorrect (0.1% per 5 mv). |
| VERTICAL/ HORIZ CAL | <p>The positions labeled around the upper half of this switch apply and are in effect when the Type 10/11M1 is in the vertical plug-in compartment. Function of each position is as follows:</p> <p>DC CALIBRATE positions (—3 CM and +3 CM) provide an accurate amount of deflection above and below the center-line for setting the gain of the vertical amplifier of the Type 647. When the vertical gain of the Type 647 is being set with a Type 10/11M1, an 11-series time base must be inserted in the horizontal plug-in compartment of the oscilloscope.</p> <p>TIME MARK position allows an external time-mark signal to be connected to the TIME MARK IN connector and be displayed on the oscilloscope.</p> <p>PULSE POLARITY positions (+ and —) reverse the polarity of the signal from the pulser.</p> <p>The positions labeled around the lower half of this switch apply and are in effect when the Type 10/11M1 is in the horizontal plug-in compartment. The HORIZ CAL positions of the switch provide the indicated amount of horizontal deflection for setting the centering and gain of the horizontal amplifier. When the horizontal centering and gain of the Type 647</p> | OUTPUT | Output connector for monitoring the information selected by the SOURCE switches. |

OPERATION

Specific operating information on the use of the Type 10/11M1 for calibrating and standardizing the Type 647 Oscilloscope is given in the oscilloscope instruction manual. The information presented in this manual is a general discussion on the various capabilities of the Type 10/11M1 Test Unit.

The Type 10/11M1 is most useful where more than one Type 647 is to be calibrated and standardized. In such a case, the gain, transient response, and power supplies of the oscilloscopes will be matched to a very high degree. This insures that the plug-in units used with the Type 647 can be freely interchanged from one oscilloscope to another without having to recalibrate the plug-in units.

Oscilloscope Transient Response

The pulser contained in the Type 10/11M1 Test Unit provides a fast-rise pulse for setting or checking the transient response of the oscilloscope. The risetime of this pulse is typically 3 nsec. To observe the output signal of the pulser on the oscilloscope, insert the Type 10/11M1 into the left-hand plug-in compartment and a time-base plug-in unit into the right-hand opening. Then, set the VERTICAL control of the Type 10/11M1 to either + or -. When operating in the + position, use the positive-going edge of the displayed waveform to adjust oscilloscope transient response. When the VERTICAL control is set to -, use the negative-going edge of the waveform for transient response adjustments. The PULSE AMPLITUDE and RATE controls determine the amplitude and repetition rate of the Pulser. Set the controls of the time-base plug-in unit for a stable internally triggered display at the desired sweep rate. Once the time base is properly triggered, triggering will be unaffected by positioning or amplitude changes with the Type 10/11M1.

Oscilloscope Vertical Deflection

The DC CALIBRATE positions of the VERTICAL switch provide an accurate dc signal that shifts the position of a free-running trace three divisions above or below the graticule centerline when the gain and centering of the Type 647 vertical amplifier are properly set. To insure correct average horizontal deflection voltage and vertical deflection sensitivity when this check or adjustment is made, the Type 10/11M1 must be in the oscilloscope vertical plug-in compartment, and an 11-series time base must be in the horizontal plug-in compartment.

Displaying Time-Mark Signals

With the VERTICAL switch set to TIME MARK, an external time-mark signal may be applied to the TIME MARK IN connector for checking or calibrating the sweep rates of a time-base unit used with the Type 647. The ATTEN control varies the displayed amplitude of the signal applied to the TIME MARK IN connector and the POSITION control positions the display vertically on the screen. Whenever it is desired to display a signal applied to the TIME MARK IN connector, the Type 10/11M1 must be in the vertical plug-in compartment of the oscilloscope.

Horizontal Deflection Calibration

The 0, 1, 5, 9, and 10 positions of the HORIZ CAL switch provide accurate dc levels that shift the position of a displayed dot the indicated number of centimeters to the right on the screen. The 0 position corresponds to the first verti-

cal graticule line on the left-hand side of the screen. In the oscilloscope, the HORIZ GAIN and HORIZ CENT adjustments must be set to make the position of the displayed dot correspond to the settings of the HORIZ CAL switch. For this check or adjustment, the Type 10/11M1 must be in the horizontal plug-in compartment of the oscilloscope.

Power Supply Checks and Adjustments

The two SOURCE switches allow ripple and dc error measurements to be made on each of the four regulated power supplies in the oscilloscope. These measurements and adjustments will be made while monitoring the signal voltage at the OUTPUT connector. Each of the measurements and adjustments is explained briefly in the following paragraphs.

Ripple Check. With the SOURCE switches set up for ripple measurement, the selected supply voltage is ac coupled to the OUTPUT connector of the Type 10/11M1. The ripple measurement at the OUTPUT connector should be measured with a highly sensitive peak-to-peak voltmeter or oscilloscope. Ripple checks can be made on each power supply in the oscilloscope at different load conditions as selected by the LOAD switch.

CAUTION

The Type 10/11M1 must be the only plug-in unit installed in the oscilloscope when the LOAD switch is set to FULL. Otherwise, the oscilloscope power supplies will be overloaded.

Voltage Check. The DC ERROR position provides a means of measuring the voltage of each oscilloscope power supply. The voltage amplitude at the OUTPUT connector is proportional to the per cent of voltage error of the power supply. Each 5-millivolt multiple at the OUTPUT connector represents 0.1% error in the supply voltage. For example, a voltage reading of +10 millivolts at the OUTPUT connector would indicate that the supply being checked is actually 0.2% higher than nominal.

When checking or adjusting the supplies in the oscilloscope, start with the -75-volt supply since this supply serves as a reference voltage for the other supplies in the oscilloscope. If the -75-volt supply is incorrect, the other supplies will also be incorrect.

Multi-Trace Sync Pulse Check. A placarded test point in the Type 10/11M1 allows a check of the multi-trace sync pulse from a time-base plug-in unit. This sync pulse should appear at the end of each sweep of the time-base plug-in unit. For this check, the Type 10/11M1 Test Unit must be in the left-hand opening and the time-base plug-in unit must be in the right-hand opening of the oscilloscope. Also, the left-hand side panel of the oscilloscope must be removed to gain access to the multi-trace sync test point in the Type 10/11M1.

SECTION 3

CIRCUIT DESCRIPTION

General Description

The Type 10/11M1 contains a vertical input amplifier stage, a variable repetition rate fast-rise square-wave pulser, dummy load resistors, and accurate dc voltage circuits for calibrating gain and power supply voltages of the oscilloscope. The unit (and schematics) has two sections; Vertical and Horizontal. The Vertical circuitry appears on the schematic titled "Pulser Circuit" and the Horizontal circuitry appears on the schematic titled "Power Supply and Horizontal Calibration". In the following discussion, refer to the appropriate schematic to locate the components mentioned.

Pulser Circuit Schematic

The following discussion deals with all the circuitry that appears on the "Pulser Circuit" schematic.

Input Amplifier. The input amplifier, (or time-mark amplifier) is a conventional single-stage transistor amplifier with a grounded emitter and loaded collector. The amplifier (Q194) is feedback stabilized through R194. Voltage gain of the stage is about $1.33\times$. The input signal (or time mark) is applied to the TIME MARK IN connector (J190) and is ac coupled to potentiometer R191 (ATTEN). The center arm of the potentiometer is coupled to the base of Q194. The diode D192 is connected to the base of Q194 to limit the negative voltage at this point.

The output signal from the collector of Q194 passes through C188 to the vertical amplifier of the oscilloscope when the VERTICAL/HORIZ CAL switch is set to TIME MARK. The signal from the collector of Q194 also passes through C198 to the time-base plug-in unit as an internal trigger signal.

Pulser Circuit. The Pulser circuit consists of a variable-frequency astable multivibrator Q115/Q125, current-switching transistors Q134/Q144, and disconnect diodes D132, D133, D142, and D143. When the PULSE RATE switch is set to any position except OFF, the multivibrator free runs at a rate determined by the capacitance selected by the PULSE RATE switch. Q164 and Q174 are common-base stages which pass the differential current signal developed by the pulser and shift it to the proper dc level.

As the multivibrator flips back and forth, Q115 and Q125 are alternately turned on and off. The signal developed across R114 (from the collector of Q115) is coupled to the time-base plug-in unit for use as an internal trigger signal. The signal from the collector of Q125 turns Q144 on and off. Since Q144 is in series with Q134, both transistors turn on and off simultaneously. (Q134 has essentially a fixed voltage on its base due to D124.) The differential current supplied through R130 and R140 is either shunted through transistors Q134 and Q144 or is conducted through

the diodes D132, D133, D142, and D143. When the transistors Q134 and Q144 are "on" the diodes are "off". When the transistors are "off" the diodes are "on". Amplitude control R135 varies the amplitude of this switched differential current. The emitters of the grounded base transistors Q164 and Q174 present a low impedance and offer a summing point for the switched differential current, through R133 and R143; the positioning current, through R148 and R158; and the fixed bias current, through R161 and R171. The speed and quality of the "switching on" of the transistors Q134 and Q144 is better than "switching off" and the former step transition should be used for transient response adjustments. This transition can be recognized as the transition from the level variable with the amplitude control to the level variable only with position control.

RC networks R163/C163 and R173/C173 provide thermal balance on both sides of the push-pull circuit. This prevents distorting voltages due to thermal shift with dissipation changes in the transistors.

Power Supply and Horizontal Calibration

Load Circuitry. Dummy load resistors are used in the Type 10/11M1 to check the oscilloscope power supply under different loading conditions. The LOAD switch, SW290, selects one of three loading conditions: ZERO, HALF, and FULL. In the ZERO position of the load switch, the only power drawn from the oscilloscope is that required for the Pulser circuit and the companion plug-in unit (if any). With the LOAD switch in the HALF position the approximate loading on the power supplies is as follows: -75-volt supply, 7 watts; -15-volt supply, 3.75 watts; +15-volt supply, 11 watts; +100-volt supply, 8 watts; +300-volt supply, 4.5 watts. With the LOAD switch in the FULL position, loading is as follows: -75-volt supply, 14.3 watts; -15-volt supply, 5.6 watts; +15-volt supply, 21.4 watts; +100-volt supply, 15.9 watts; +300-volt supply, 9 watts.

CAUTION

The Type 10/11M1 must be the only plug-in unit in the oscilloscope when the LOAD switch is in the FULL position; otherwise the power supplies of the oscilloscope will be overloaded.

Horiz Cal Circuitry. The Horiz Cal circuitry is a precision dc current source for calibrating the gain of the horizontal amplifier in the oscilloscope. Sensitivity of the horizontal amplifier in the oscilloscope is $347\ \mu\text{a}$ per division of deflection. Each 54 k resistor (R265 and R267) in the circuit can be thought of as supplying the proper amount of current for deflecting the oscilloscope beam exactly 4 divisions (centimeters). Each 216 k resistor (R264 and R269) deflects the beam 1 division (centimeter). The HORIZ CAL switch arranges the precision resistors in various ways to obtain 0, 1, 5, 9, and 10 divisions of deflection on the crt.

Circuit Description—Type 10/11M1

Dc Error Circuitry. The Dc Error circuitry checks the voltage of each power supply in the oscilloscope. The voltage at the OUTPUT connector of the Type 10/11M1 is proportional to a percentage of error in a given supply when the function switch is set to DC ERROR (i.e., each 5 millivolts at the OUTPUT connector equals 0.1% error in the supply voltage that is being checked).

Operation of the Dc Error circuitry is as follows: the circuit contains two Zener-regulated voltage dividers with nominal output voltages of +9 volts and -9 volts. The +9-volt divider is regulated by Zener diode D206 and the -9-volt divider is regulated with D214. These two voltages are used as the reference voltages when checking the various supply voltages of the oscilloscope. The +SUPPLY REF and -SUPPLY REF adjustments vary the dividers slightly so that they are in the range of adjustment of all of the CALIB adjustments (R220, R230, R240, and R250). This is necessary because of the voltage tolerance of the Zener diodes (D206 and D214). The voltage of each regulated supply in the oscilloscope is coupled through a resistance divider in the Error circuit. Each of these voltage dividers is designed to reduce the voltage of each supply to either + or -9 volts, depending on the polarity of the supply. The negative supply voltages are compared to the +9-volt reference and the positive supply voltages are compared to the -9-volt reference. The algebraic sum of the comparison of each supply voltage is coupled to the OUTPUT connector of the Type 10/11M1. The algebraic sum of the comparison will be exactly zero volts when there is no error in the supply voltage (i.e., (+9 v) + (-9 v) = 0 v). Fig. 3-1 shows a simplified drawing of the Error circuit with the +100-volt supply connected for comparison.

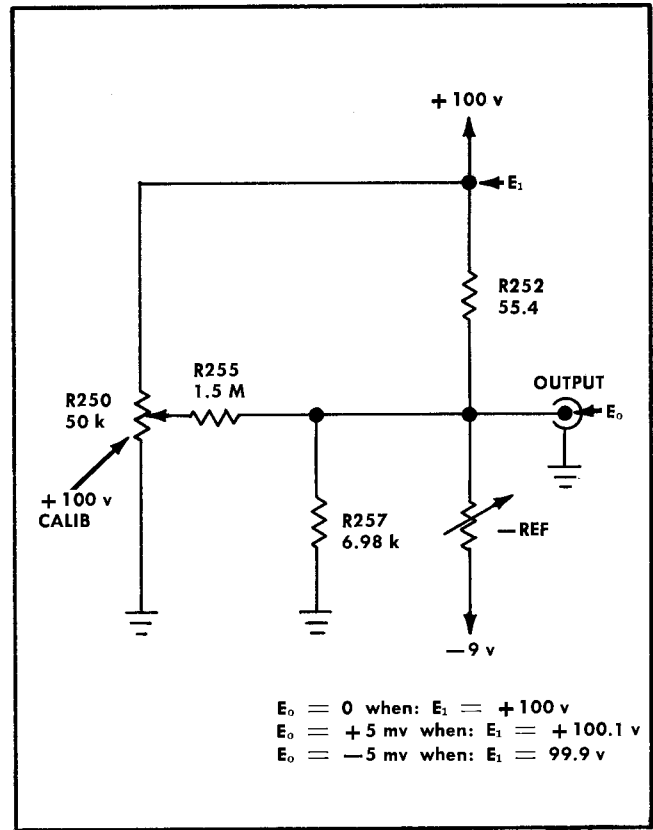

Fig. 3-1. Simplified schematic of the Error circuit with the +100-volt supply connector for comparison.

SECTION 4

MAINTENANCE AND CALIBRATION

MAINTENANCE

Visual Inspection

The instrument should be visually inspected occasionally for such defects as poor connections, broken or damaged ceramic terminal strips, improperly seated transistors, and heat-damaged parts. The remedy for most of these defects is obvious. But a heat-damaged component is usually the symptom of some defect that is not obvious. The cause of overheating should be determined and corrected before the part is replaced, otherwise the damage may be repeated.

Transistor Checks

Periodic preventive maintenance checks on the transistors in the Type 10/11M1 are not recommended. Satisfactory operation of the instrument in all respects is adequate assurance that the transistors are performing properly.

Recalibration

To insure that the Type 10/11M1 maintains its accuracy, check the calibration after each 500 hours of operation or every six months if used intermittently. Complete calibration instructions appear later in this section.

The calibration procedure can also be helpful in isolating troubles in the instrument. Also, minor troubles in the instrument that may not be apparent during normal operation may be revealed and corrected during calibration.

Ordering Parts

Many of the components in the Type 10/11M1 are standard electronic parts that may be purchased locally. However, all parts in the instrument can be obtained from Tektronix through your local Tektronix Field Engineer or Field Office. Before ordering, consult the parts list of this manual to determine the value, tolerance, and rating required.

Some of the parts used in the Type 10/11M1 are not standard parts and can only be purchased from Tektronix through your local Tektronix Field Engineer or Field Office.

Soldering to Ceramic Strips

Special silver-bearing solder is used to establish a bond to ceramic terminal strips in Tektronix instruments. This bond can be broken by repeated soldering (especially if ordinary tin-lead solder is used) or by excessive heating. The silver-bearing solder used should contain about 3% silver. Silver-bearing solder is usually available locally or may be purchased from Tektronix in one-pound rolls; order by part number 251-514.

When soldering to ceramic terminal strips:

1. Use a wedge-shaped soldering iron tip about $\frac{1}{8}$ inch wide. This will allow you to apply heat directly to the solder in the notch and thereby reduce the overall heating effect.
2. Maintain a clean, properly tinned tip.
3. Use a hot iron for a short time. A 50- to 75-watt iron is usually adequate.
4. Avoid putting pressure on the strip with the soldering iron or other tools. Excessive pressure can crack or chip the strip.

Replacing Ceramic Terminal Strips

Fig. 4-1 shows an assembled ceramic terminal strip. Replacement strips with studs attached are supplied under a single part number and the spacers under another number. The original spacers may be reused if they are not damaged. Usually, the old strip can be pried or pulled out of the chassis with a pair of pliers. In some cases, you may choose to use a hammer and punch to drive the studs out of the chassis.

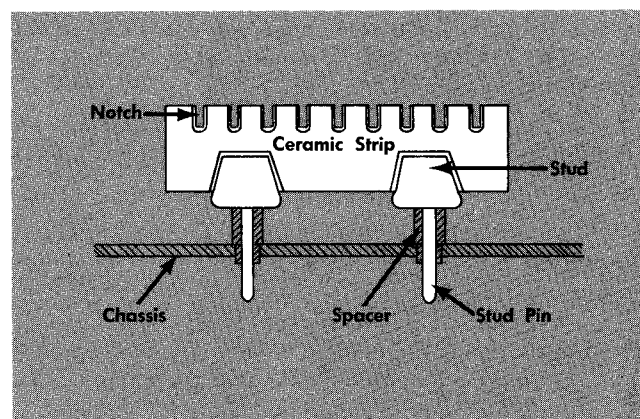

Fig. 4-1. Ceramic strip assembly.

Once the damaged strip has been removed, place the new or used (but undamaged) spacers in the chassis holes. Then carefully force the studs of the new strip into the spacers until they are completely seated. If necessary, use a soft-faced mallet and lightly tap the strip directly over the stud to seat the studs in the spaces.

Replacing Wafer Switches

Individual wafers are normally not replaced in the wafer switches. Complete switch assemblies, either wired or unwired, may be ordered from Tektronix. See the Parts List, Section 5 of this manual.

When soldering leads to a switch, do not let solder flow around and beyond the terminal rivet since this can destroy the spring tension of the contact.

Troubleshooting Aids

The Type 10/11M1 contains certain features intended to speed and simplify troubleshooting and maintenance. Most of the wire in the instrument is color coded to aid in circuit tracing. All regulated power supply leads are coded as follows:

1. The basic wire color indicates voltage polarity; tan for negative and white for positive.
2. The stripe colors indicate supply voltage according to the standard EIA color code. Stripes are read in the order of decreasing width.

For example, the -75-volt supply leads are tan wire (negative) bearing stripes of violet (seven), green (five), and black (no zero).

The instrument contains a number of stable metal-film resistors identified by their gray background color and color-coding. If a resistor has three significant figures and a multiplier, it will be EIA color coded. If it has four significant figures and multiplier, the value will be printed on the body of the resistor. For example, a 333 k resistor will be color coded but a 333.5 k resistor will have its value printed on the resistor body. The color coding sequence is shown in Table 4-1 and Fig. 4-2.

Switch wafers shown on the schematics are coded to indicate the physical positions of the wafers on a rotary switch. The number portion of the code refers to the wafer position as counted from the front- or driven-end of the switch shaft. Letters F and R identify the front or rear of a given wafer.

Several diode types are used in the Type 10/11M1. Fig 4-3 shows how to identify the polarity of the various diodes.

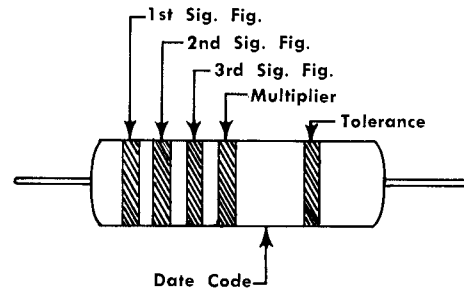

Fig. 4-2. Standard EIA color code for metal-film resistors.

strument will not require frequent calibration but will need occasional adjustments as components age or are replaced.

Calibration is a valuable part of preventive maintenance since many types of minor troubles may be discovered and corrected before they become serious enough to disable the instrument. Also, certain troubles can be easily isolated to a particular section of the instrument by attempting calibration.

Equipment Required

1. Calibrated Tektronix Type 647 or Type RM647 Oscilloscope (plug-in extension required with Type RM647).
2. Calibrated Tektronix Type 11B-series time-base plug-in unit.

TABLE 4-1

Color Code Sequence

| Color | 1st Sig. Fig. | 2nd Sig. Fig. | 3rd Sig. Fig. | Multiplier | (±) % Tolerance |
|----------|---------------|---------------|---------------|---------------|-----------------|
| Black | 0 | 0 | 0 | 1 | — |
| Brown | 1 | 1 | 1 | 10 | 1 |
| Red | 2 | 2 | 2 | 100 | 2 |
| Orange | 3 | 3 | 3 | 1,000 | — |
| Yellow | 4 | 4 | 4 | 10,000 | — |
| Green | 5 | 5 | 5 | 100,000 | 0.50 |
| Blue | 6 | 6 | 6 | 1,000,000 | 0.25 |
| Violet | 7 | 7 | 7 | 10,000,000 | 0.10 |
| Gray | 8 | 8 | 8 | 100,000,000 | 0.05 |
| White | 9 | 9 | 9 | 1,000,000,000 | — |
| Gold | — | — | — | 0.1 | 5 |
| Silver | — | — | — | 0.01 | — |
| No Color | — | — | — | — | 10 |

CALIBRATION

Introduction

This portion of the manual contains a complete calibration procedure for the Type 10/11M1 Test Unit. The in-

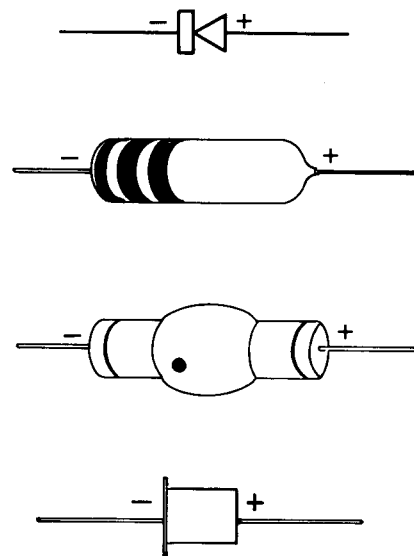

Fig. 4-3. Typical diode polarities.

3. Dc differential voltmeter such as a John Fluke Model 803 or equivalent. Accuracy of at least $\pm 0.05\%$ at readings of 15 volts, 75 volts, and 100 volts.

4. Test oscilloscope such as a Tektronix Type 530- or 540-series with a Type D Plug-In Unit. The oscilloscope must be dc coupled and have a deflection factor of 1 mv/cm.

5. A source of line voltage within the regulating range of the Type 647 Oscilloscope.

Preliminary Procedure

1. Insert the Type 10/11M1 into the left-hand plug-in compartment of the Type 647 Oscilloscope. (The right-hand compartment should be empty.)

2. Apply line power to the Type 647 and turn on its POWER ON switch.

3. Allow at least 5 minutes for the Type 647 to warm up and stabilize.

4. Set the front-panel controls of the Type 10/11M1 and Type 647 as follows:

Type 10/11M1

| | |
|--------------------|--------------|
| PULSE RATE | OFF |
| POSITION | Centered |
| VERTICAL HORIZ CAL | TIME MARK |
| LOAD | ZERO |
| Other controls | Any position |

Type 647

| | |
|-----------------|--------------|
| 1 KC CALIBRATOR | OFF |
| INTENSITY | ccw |
| ON OFF | POWER ON |
| Other controls | Any position |

Check and Adjustment Procedure

Dc Error Calibration. This procedure describes how to set the +SUPPLY REF, -SUPPLY REF, -75 V CALIB, -15 V CALIB, +15 V CALIB and +100 V CALIB adjustments. This is accomplished by first setting the power supplies of the Type 647 with the accurate differential voltmeter. Then, the Type 10/11M1 adjustments are set to match the power supplies of the Type 647. The complete procedure is as follows:

1. Connect the precision differential voltmeter (item 3 under "Equipment Required") to the -75-volt supply in the Type 647 Oscilloscope.

NOTE

The -75-volt supply leads in the oscilloscope are color coded: tan wire with a violet stripe, a green stripe, and a black stripe.

2. Adjust the -75-volt power supply adjustments in the oscilloscope for a null of exactly 75 volts on the differential voltmeter.

3. Repeat steps 1 and 2 for the -15-, +15-, and +100-volt supplies of the Type 647 Oscilloscope. The supply leads are color coded as follows:

- 15-volt supply tan wire with a brown stripe, green stripe, and a black stripe.
- +15-volt supply white wire with a brown stripe, green stripe, and black stripe.
- +100-volt supply white wire with two brown stripes and a black stripe.

4. Connect the test oscilloscope (item 4 of "Equipment Required") to the OUTPUT connector of the Type 10/11M1.

5. Free run the test oscilloscope and set the SOURCE function switch of the Type 10/11M1 to GND.

6. Establish a ground reference on the test oscilloscope by positioning the free-running trace to the horizontal center-line.

7. Set the SOURCE function of the Type 10/11M1 to DC ERROR.

8. Switch the SOURCE voltage switch of the Type 10/11M1 alternately between the -75 V and -15 V positions and set the deflection factor of the test oscilloscope so that the trace is on the screen in both positions of the SOURCE voltage switch. Do not move the POSITION control of the test oscilloscope as this will destroy the ground reference.

9. Adjust the -SUPPLY REF potentiometer in the Type 10/11M1 for approximately equal and opposite deflection above and below the ground reference point on the oscilloscope.

10. Repeat steps 8 and 9 using the +100 V and +15 V positions of the SOURCE voltage switch and adjust the +SUPPLY REF potentiometer in the Type 10/11M1 for approximately equal and opposite deflection above and below the ground reference point on the oscilloscope.

11. While switching between the GND and DC ERROR positions of the SOURCE function switch, adjust each of the CALIB adjustments of the Type 10/11M1 to within ± 5 millivolts as measured on the test oscilloscope. See the following:

| SOURCE Voltage Switch Setting | Adjust |
|-------------------------------|--------------------|
| -75 V | R220, -75 V CALIB |
| -15 V | R230, -15 V CALIB |
| +15 V | R240, +15 V CALIB |
| +100 V | R250, +100 V CALIB |

12. Disconnect the test oscilloscope from the OUTPUT connector.

SECTION 5

PARTS LIST and DIAGRAMS

PARTS ORDERING INFORMATION

Replacement parts are available from or through your local Tektronix Field Office.



Changes to Tektronix instruments are sometimes made to accommodate improved components as they become available, and to give you the benefit of the latest circuit improvements developed in our engineering department. It is therefore important, when ordering parts, to include the following information in your order: Part number including any suffix, instrument type, serial number, and modification number if applicable.

If a part you have ordered has been replaced with a new or improved part, your local Tektronix Field Office will contact you concerning any change in part number.

ABBREVIATIONS AND SYMBOLS

| | | | |
|----------|-----------------------------|----------|-----------------------------------|
| a or amp | amperes | mm | millimeter |
| BHS | binding head steel | meg or M | megohms or mega (10^6) |
| C | carbon | met. | metal |
| cer | ceramic | μ | micro, or 10^{-6} |
| cm | centimeter | n | nano, or 10^{-9} |
| comp | composition | Ω | ohm |
| cps | cycles per second | OD | outside diameter |
| crt | cathode-ray tube | OHS | oval head steel |
| CSK | counter sunk | p | pico, or 10^{-12} |
| dia | diameter | PHS | pan head steel |
| div | division | piv | peak inverse voltage |
| EMC | electrolytic, metal cased | plstc | plastic |
| EMT | electrolytic, metal tubular | PMC | paper, metal cased |
| ext | external | poly | polystyrene |
| f | farad | Prec | precision |
| F & I | focus and intensity | PT | paper tubular |
| FHS | flat head steel | PTM | paper or plastic, tubular, molded |
| Fil HS | fillister head steel | RHS | round head steel |
| g or G | giga, or 10^9 | rms | root mean square |
| Ge | germanium | sec | second |
| GMV | guaranteed minimum value | Si | silicon |
| h | henry | S/N | serial number |
| hex | hexagonal | t or T | tera, or 10^{12} |
| HHS | hex head steel | TD | toroid |
| HSS | hex socket steel | THS | truss head steel |
| HV | high voltage | tub. | tubular |
| ID | inside diameter | v or V | volt |
| incd | incandescent | Var | variable |
| int | internal | w | watt |
| k or K | kilohms or kilo (10^3) | w/ | with |
| kc | kilocycle | w/o | without |
| m | milli, or 10^{-3} | WW | wire-wound |
| mc | megacycle | | |

SPECIAL NOTES AND SYMBOLS

| | |
|---|---|
| X000 | Part first added at this serial number. |
| 000X | Part removed after this serial number. |
| *000-000 | Asterisk preceding Tektronix Part Number indicates manufactured by or for Tektronix, or reworked or checked components. |
| Use 000-000 | Part number indicated is direct replacement. |
|  | Internal screwdriver adjustment. |
|  | Front-panel adjustment or connector. |

EXPLODED VIEW

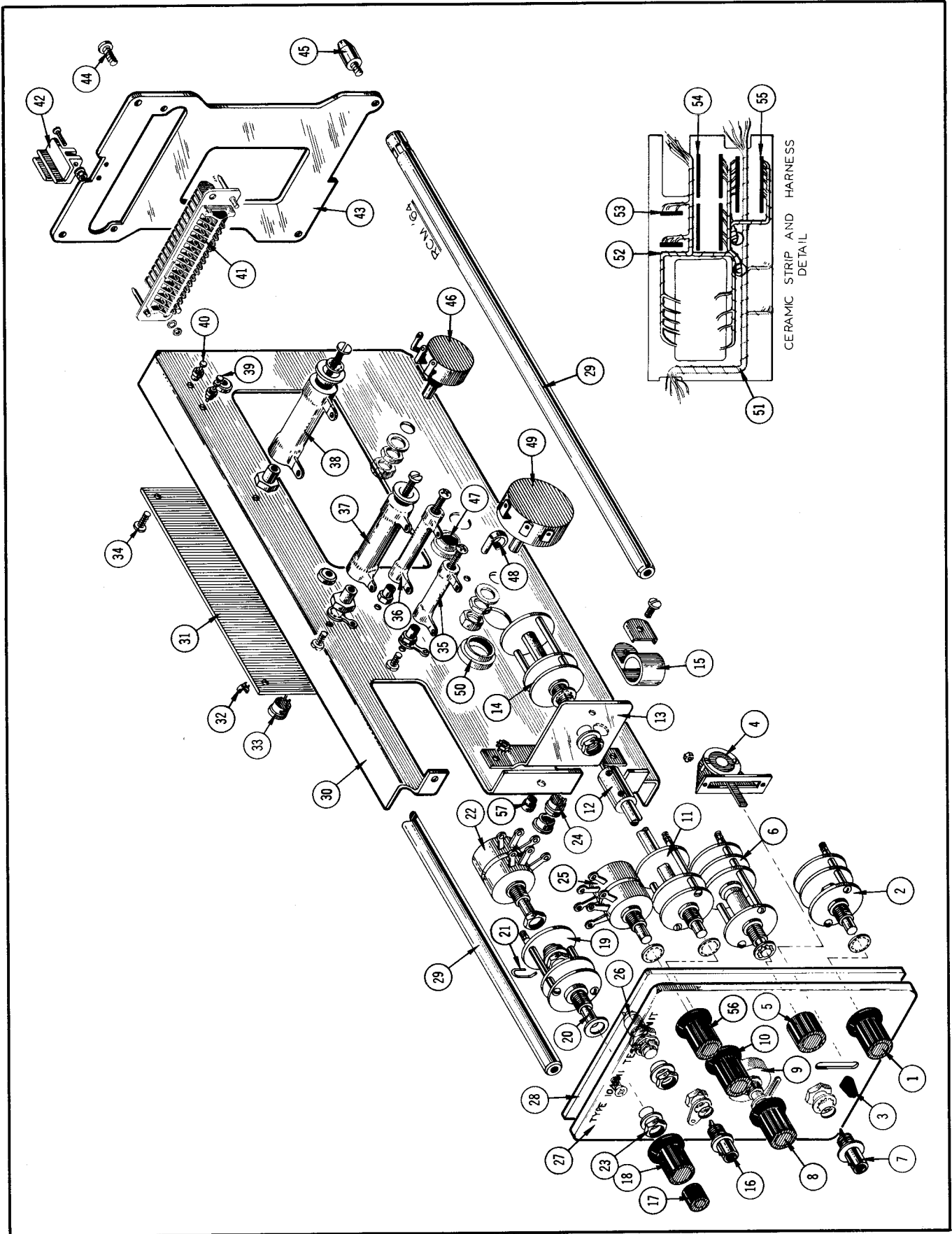

EXPLODED VIEW

| REF. NO. | PART NO. | SERIAL/MODEL NO. | | QTY. | DESCRIPTION |
|----------|----------|------------------|-------|------|--|
| | | EFF. | DISC. | | |
| 1 | 366-173 | | | 1 | KNOB, small charcoal — SOURCE VOLTAGE |
| | - - - - | | | - | Includes: |
| | 213-004 | | | 1 | SCREW, set, 6-32 x 3/16 inch HSS |
| 2 | 260-630 | | | 1 | SWITCH, unwired — SOURCE VOLTAGE |
| | - - - - | | | - | Mounting Hardware: (not included) |
| | 210-012 | | | 1 | LOCKWASHER, internal, 3/8 x 1/2 inch |
| | 210-840 | | | 1 | WASHER, .390 ID x 9/16 inch OD |
| | 210-413 | | | 1 | NUT, hex, 3/8-32 x 1/2 inch |
| 3 | 366-215 | | | 1 | KNOB, lever — SOURCE FUNCTION |
| 4 | 260-490 | | | 1 | SWITCH, lever — SOURCE FUNCTION |
| | - - - - | | | - | Mounting Hardware: (not included) |
| | 210-586 | | | 2 | NUT, keps, 4-40 x 1/4 inch |
| 5 | 366-280 | | | 1 | KNOB, small charcoal — LOAD |
| | - - - - | | | - | Includes: |
| | 213-004 | | | 1 | SCREW, set, 6-32 x 3/16 inch HSS |
| 6 | 260-626 | | | 1 | SWITCH, unwired — LOAD |
| | - - - - | | | - | Mounting Hardware: (not included) |
| | 210-012 | | | 1 | LOCKWASHER, internal, 3/8 x 1/2 inch |
| | 210-840 | | | 1 | WASHER, .390 ID x 9/16 inch OD |
| | 210-413 | | | 1 | NUT, hex, 3/8-32 x 1/2 inch |
| 7 | 131-274 | | | 1 | CONNECTOR, chassis mounted, BNC, with hardware |
| 8 | 366-173 | | | 1 | KNOB, small charcoal — ATTEN |
| | - - - - | | | - | Includes |
| | 213-004 | | | 1 | SCREW, set, 6-32 x 3/16 inch HSS |
| 9 | - - - - | | | 1 | POT |
| | - - - - | | | - | Mounting Hardware: (not included) |
| | 210-207 | | | 1 | LUG, solder, 3/8 inch |
| | 210-012 | | | 1 | LOCKWASHER, internal, 3/8 x 1/2 inch |
| | 210-840 | | | 1 | WASHER, .390 ID x 9/16 inch OD |
| | 210-413 | | | 1 | NUT, hex, 3/8-32 x 1/2 inch |
| 10 | 366-172 | | | 1 | KNOB, small charcoal — VERTICAL/HORIZ CAL |
| | - - - - | | | - | Includes |
| | 213-004 | | | 1 | SCREW, set, 6-32 x 3/16 inch HSS |
| 11 | 262-672 | | | 1 | SWITCH, wired — HORIZ CAL |
| | - - - - | | | - | Includes: |
| | 260-629 | | | 1 | SWITCH, unwired — HORIZ CAL |
| | - - - - | | | - | Mounting Hardware: (not included) |
| | 210-012 | | | 1 | LOCKWASHER, internal, 3/8 x 1/2 inch |
| | 210-840 | | | 1 | WASHER, .390 ID x 9/16 inch OD |
| | 210-413 | | | 1 | NUT, hex, 3/8-32 x 1/2 inch |
| 12 | 376-007 | | | 1 | COUPLING |
| | - - - - | | | - | Includes: |
| | 213-005 | | | 2 | SCREW, set, 8-32 x 1/8 inch HSS |
| 13 | 407-068 | | | 1 | BRACKET, switch |
| | - - - - | | | - | Mounting Hardware: (not included) |
| | 211-510 | | | 2 | SCREW, 6-32 x 3/8 inch BHS |
| | 210-457 | | | 2 | NUT, keps, 6-32 x 5/16 inch |

EXPLODED VIEW (Cont'd)

| REF. NO. | PART NO. | SERIAL/MODEL NO. | | QTY. | DESCRIPTION |
|----------|----------|------------------|-------|------|--|
| | | EFF. | DISC. | | |
| 14 | 262-671 | | | 1 | SWITCH, wired — VERTICAL |
| | - - - - | | | - | Includes: |
| | 260-628 | | | 1 | SWITCH, unwired — VERTICAL |
| | - - - - | | | - | Mounting Hardware: (not included) |
| | 210-012 | | | 1 | LOCKWASHER, internal, $\frac{3}{8}$ x $\frac{1}{2}$ inch |
| | 210-840 | | | 1 | WASHER, .390 ID x $\frac{9}{16}$ inch OD |
| | 210-413 | | | 1 | NUT, hex, $\frac{3}{8}$ -32 x $\frac{1}{2}$ inch |
| 15 | 343-007 | | | 1 | CLAMP, cable, $\frac{5}{8}$ inch |
| | - - - - | | | - | Mounting Hardware: (not included) |
| | 210-863 | | | 1 | WASHER, "D" type, #10 |
| | 211-507 | | | 1 | SCREW, 6-32 x $\frac{5}{16}$ inch BHS |
| 16 | 131-106 | | | 1 | CONNECTOR, chassis mounted, BNC |
| | - - - - | | | - | Mounting Hardware: (not included) |
| | 210-255 | | | 1 | LUG, solder, $\frac{3}{8}$ inch |
| | 210-413 | | | 1 | NUT, hex, $\frac{3}{8}$ -32 x $\frac{1}{2}$ inch |
| 17 | 366-189 | | | 1 | KNOB, small red — AMPLITUDE |
| | - - - - | | | - | Includes: |
| | 213-020 | | | 1 | SCREW, set, 6-32 x $\frac{1}{8}$ inch HSS |
| 18 | 366-175 | | | 1 | KNOB, small charcoal — PULSE RATE |
| | - - - - | | | - | Includes: |
| | 213-004 | | | 1 | SCREW, set, 6-32 x $\frac{3}{16}$ inch HSS |
| 19 | 262-670 | | | 1 | SWITCH, wired — PULSE RATE |
| | - - - - | | | - | Includes: |
| | 260-627 | | | 1 | SWITCH, unwired — PULSE RATE |
| 20 | 384-323 | | | 1 | ROD, extension |
| 21 | 376-014 | | | 1 | COUPLING, pot |
| 22 | - - - - | | | 1 | POT |
| | - - - - | | | - | Mounting Hardware: (not included) |
| | 210-413 | | | 2 | NUT, hex, $\frac{3}{8}$ -32 x $\frac{1}{2}$ inch |
| | 210-012 | | | 1 | LOCKWASHER, internal, $\frac{3}{8}$ x $\frac{1}{2}$ inch |
| 23 | - - - - | | | - | Mounting Hardware For Switch Assembly: (not included) |
| | 210-012 | | | 1 | LOCKWASHER, internal, $\frac{3}{8}$ x $\frac{1}{2}$ inch |
| | 210-840 | | | 1 | WASHER, .390 ID x $\frac{9}{16}$ inch OD |
| | 210-413 | | | 1 | NUT, hex, $\frac{3}{8}$ -32 x $\frac{1}{2}$ inch |
| 24 | 136-181 | | | 1 | SOCKET, 3 pin transistor |
| | - - - - | | | - | Mounting Hardware: (not included) |
| | 354-234 | | | 1 | RING, locking, transistor socket |
| 25 | - - - - | | | 1 | POT |
| | - - - - | | | - | Mounting Hardware: (not included) |
| | 210-012 | | | 1 | LOCKWASHER, internal, $\frac{3}{8}$ x $\frac{1}{2}$ inch |
| | 210-840 | | | 1 | WASHER, .390 ID x $\frac{9}{16}$ inch OD |
| | 210-413 | | | 1 | NUT, hex, $\frac{3}{8}$ -32 x $\frac{1}{2}$ inch |
| 26 | 136-164 | | | 1 | SOCKET, lamp |
| | - - - - | | | - | Mounting Hardware: (not included) |
| | 210-413 | | | 1 | NUT, hex, $\frac{3}{8}$ -32 x $\frac{1}{2}$ inch |
| | 210-012 | | | 1 | LOCKWASHER, internal, $\frac{3}{8}$ x $\frac{1}{2}$ inch |
| | 210-978 | | | 1 | WASHER, $\frac{3}{8}$ ID x $\frac{1}{2}$ inch OD |
| | 210-590 | | | 1 | NUT, hex, $\frac{3}{8}$ -32 x $\frac{7}{16}$ inch |
| 27 | 333-862 | | | 1 | PANEL, front |
| 28 | 387-981 | | | 1 | PLATE, front sub-panel |
| 29 | 384-615 | | | 4 | ROD, spacer |

EXPLODED VIEW (Cont'd)

| REF. NO. | PART NO. | SERIAL/MODEL NO. | | QTY. | DESCRIPTION |
|----------|----------|------------------|-------|------|--|
| | | EFF. | DISC. | | |
| 30 | 441-584 | | | 1 | CHASSIS, aluminum |
| | - - - - | | | - | Mounting Hardware: (not included) |
| | 211-507 | | | 3 | SCREW, 6-32 x $\frac{5}{16}$ inch BHS |
| | 211-538 | | | 3 | SCREW, 6-32 x $\frac{5}{16}$ inch FHS phillips |
| 31 | 670-067 | | | 1 | ASSEMBLY, printed circuit board |
| | - - - - | | | - | Includes: |
| 32 | 344-064 | | | 8 | CLIP, diode |
| 33 | 136-183 | | | 4 | SOCKET, 3 pin transistor |
| | - - - - | | | - | Mounting Hardware For Circuit Board Assy: (not included) |
| 34 | 211-008 | | | 4 | SCREW, 4-40 x $\frac{1}{4}$ inch BHS |
| 35 | - - - - | | | 1 | RESISTOR, 8 watt |
| | - - - - | | | - | Mounting Hardware: (not included) |
| | 211-545 | | | 1 | SCREW, 6-32 x $1\frac{1}{4}$ inches THS phillips |
| | 210-478 | | | 1 | NUT, hex, resistor mounting |
| | 210-206 | | | 1 | LUG, solder, SE10 long |
| | 211-507 | | | 1 | SCREW, 6-32 x $\frac{5}{16}$ inch BHS |
| 36 | - - - - | | | 3 | RESISTOR, 10 watt |
| | - - - - | | | - | Mounting Hardware For Each: (not included) |
| | 211-553 | | | 1 | SCREW, 6-32 x $1\frac{1}{2}$ inches RHS phillips |
| | 210-601 | | | 1 | EYELET |
| | 210-478 | | | 1 | NUT, hex, resistor mounting |
| | 211-507 | | | 1 | SCREW, 6-32 x $\frac{5}{16}$ inch BHS |
| 37 | - - - - | | | 1 | RESISTOR, 20 watt |
| | - - - - | | | - | Mounting Hardware: (not included) |
| | 212-037 | | | 1 | SCREW, 8-32 x $1\frac{3}{4}$ inches Fil HS |
| | 210-808 | | | 1 | WASHER, centering |
| | 210-462 | | | 1 | NUT, hex, resistor mounting |
| | 210-206 | | | 1 | LUG, solder, SE10, long |
| | 212-004 | | | 1 | SCREW, 8-32 x $\frac{5}{16}$ inch BHS |
| 38 | - - - - | | | 6 | RESISTOR, 25 watt |
| | - - - - | | | - | Mounting Hardware For Each: (not included) |
| | 212-037 | | | 1 | SCREW, 8-32 x $1\frac{3}{4}$ inches Fil HS |
| | 210-008 | | | 1 | LOCKWASHER, internal, #8 |
| | 210-809 | | | 1 | WASHER, centering |
| | 210-462 | | | 1 | NUT, hex, resistor mounting |
| | 212-004 | | | 1 | SCREW, 8-32 x $\frac{5}{16}$ inch BHS |
| 39 | 131-359 | | | 1 | CONNECTOR, terminal feed-thru |
| | - - - - | | | - | Mounting Hardware: (not included) |
| | 358-176 | | | 1 | BUSHING, teflon |
| 40 | 131-227 | | | 1 | CONNECTOR, terminal standoff |
| | - - - - | | | - | Mounting Hardware: (not included) |
| | 358-176 | | | 1 | BUSHING, teflon |
| 41 | 131-096 | | | 1 | CONNECTOR, chassis mounted, 32 contact, male |
| | - - - - | | | - | Mounting Hardware: (not included) |
| | 211-008 | | | 2 | SCREW, 4-40 x $\frac{1}{4}$ inch BHS |
| | 210-201 | | | 2 | LUG, solder, SE4 |
| | 210-406 | | | 2 | NUT, hex, 4-40 x $\frac{3}{16}$ inch |
| 42 | 351-063 | | | 2 | GUIDE, shoe, plug-in latch |
| | - - - - | | | - | Mounting Hardware For Each: (not included) |
| | 211-012 | | | 2 | SCREW, 4-40 x $\frac{3}{8}$ inch BHS |
| | 210-004 | | | 2 | LOCKWASHER, internal, #4 |
| | 210-406 | | | 2 | NUT, hex, 4-40 x $\frac{3}{16}$ inch |

EXPLODED VIEW (Cont'd)

| REF. NO. | PART NO. | SERIAL/MODEL NO. | | QTY. | DESCRIPTION |
|----------|----------|------------------|-------|------|--|
| | | EFF. | DISC. | | |
| 43 | 387-777 | | | 1 | PLATE, rear |
| | - - - - | | | - | Mounting Hardware: (not included) |
| 44 | 212-044 | | | 2 | SCREW, 8-32 x 1/2 inch RHS phillips |
| 45 | 214-370 | | | 2 | PIN, locating |
| 46 | - - - - | | | 5 | POT |
| | - - - - | | | - | Mounting Hardware For Each: (not included) |
| | 210-840 | | | 1 | WASHER, .390 ID x 9/16 inch OD |
| | 210-413 | | | 1 | NUT, hex, 3/8-32 x 1/2 inch |
| | 220-427 | | | 1 | NUT, jam, 3/8-32 x 1/2 x 7/32 inch thick |
| 47 | 348-063 | | | 1 | GROMMET, delrin, 1/2 inch |
| 48 | 343-089 | | | 1 | CLAMP, cable, size "D" |
| 49 | - - - - | | | 1 | POT |
| | - - - - | | | - | Mounting Hardware: (not included) |
| | 210-013 | | | 1 | LOCKWASHER, internal, 3/8 x 11/16 inch |
| | 210-840 | | | 1 | WASHER, .390 ID x 9/16 inch OD |
| | 210-413 | | | 1 | NUT, hex, 3/8-32 x 1/2 inch |
| | 220-427 | | | 1 | NUT, jam, 3/8-32 x 1/2 x 7/32 inch thick |
| 50 | 348-064 | | | 1 | GROMMET, delrin, 5/8 inch |
| 51 | 179-936 | | | 1 | CABLE HARNESS, coaxial |
| 52 | 179-935 | | | 1 | CABLE HARNESS, chassis |
| 53 | 124-149 | | | 2 | STRIP, ceramic, 7/16 inch x 7 notches |
| | - - - - | | | - | Each Includes: |
| | 355-046 | | | 2 | STUD, nylon |
| | - - - - | | | - | Mounting Hardware For Each: (not included) |
| | 361-009 | | | 2 | SPACER, nylon, .313 inch |
| 54 | 124-146 | | | 4 | STRIP, ceramic, 7/16 inch x 16 notches |
| | - - - - | | | - | Each Includes: |
| | 355-046 | | | 2 | STUD, nylon |
| | - - - - | | | - | Mounting Hardware For Each: (not included) |
| | 361-009 | | | 2 | SPACER, nylon, .313 inch |
| 55 | 124-145 | | | 2 | STRIP, ceramic, 7/16 inch x 20 notches |
| | - - - - | | | - | Each Includes: |
| | 355-046 | | | 2 | STUD, nylon |
| | - - - - | | | - | Mounting Hardware For Each: (not included) |
| | 361-009 | | | 2 | SPACER, nylon, .313 inch |
| 56 | 366-148 | | | 1 | KNOB, small charcoal — POSITION |
| | - - - - | | | - | Includes: |
| | 213-004 | | | 1 | SCREW, set, 6-32 x 3/16 inch HSS |
| 57 | 348-055 | | | 2 | GROMMET, delrin, 1/4 inch |

ELECTRICAL PARTS

Values are fixed unless marked Variable.

| Ckt. No. | Tektronix Part No. | Description | S/N Range |
|-------------|--------------------|--------------------------|-----------------------|
| Bulb | | | |
| B289 | 150-043 | Bulb Ass'y, Incandescent | 6.3 V AC AT CONNECTOR |

CapacitorsTolerance $\pm 20\%$ unless otherwise indicated.

Tolerance of all electrolytic capacitors as follows (with exceptions):

3 V — 50 V = -10% , $+250\%$
 51 V — 350 V = -10% , $+100\%$
 351 V — 450 V = -10% , $+50\%$

| | | | | | |
|-------|---------|----------------|----------|-------|-----------------|
| C111 | 281-518 | 47 pf | Cer | 500 v | |
| C113A | 290-217 | 250 μ f | EMT | 12 v | |
| C113B | 290-217 | 250 μ f | EMT | 12 v | |
| C113C | 283-019 | 2.2 μ f | Cer | 3 v | -0% 100+% |
| C113D | 283-004 | 0.02 μ f | Cer | 150 v | |
| C113F | 283-028 | 0.0022 μ f | Cer | 50 v | |
| C119 | 281-525 | 470 pf | Cer | 500 v | |
| C121 | 281-518 | 47 pf | Cer | 500 v | |
| C130 | 283-057 | 0.1 μ f | Cer | 200 v | |
| C136 | 281-544 | 5.6 pf | Cer | 500 v | 10% |
| C150 | 283-081 | 0.1 μ f | Cer | 25 v | -20% $+80\%$ |
| C161 | 283-081 | 0.1 μ f | Cer | 25 v | -20% $+80\%$ |
| C164 | 283-003 | 0.01 μ f | Cer | 150 v | |
| C171 | 283-081 | 0.1 μ f | Cer | 25 v | -20% $+80\%$ |
| C174 | 283-003 | 0.01 μ f | Cer | 150 v | |
| C176 | 290-106 | 10 μ f | EMT | 15 v | -10% $+75\%$ |
| C180 | 285-633 | 0.22 μ f | PTM | 100 v | 10% |
| C188 | 285-555 | 0.1 μ f | PTM | 100 v | |
| C190 | 283-008 | 0.1 μ f | Cer | 500 v | |
| C192 | 285-555 | 0.1 μ f | PTM | 100 v | |
| C198 | 285-598 | 0.01 μ f | PTM | 100 v | 5% |
| C199 | 281-523 | 100 pf | Selected | | |
| C259 | 285-528 | 0.1 μ f | PTM | 600 v | |

Diodes

| | | | |
|------|----------|------------------------|----------|
| D124 | *152-075 | Germanium | Tek Spec |
| D132 | *152-164 | Tek GaAs (matched set) | |
| D133 | | | |
| D142 | | | |
| D143 | | | |

Parts List — Type 10/11M1

Diodes (Cont'd)

| Ckt. No. | Tektronix Part No. | Description | | | S/N Range |
|----------|--------------------|-------------|--------|-------------|-----------|
| D170 | 152-141 | Silicon | 1N3605 | | |
| D192 | 152-141 | Silicon | 1N3605 | | |
| D201 | †152-124 | Zener | 1N938A | (0.001%/°C) | |
| D202 | †152-124 | Zener | 1N938A | (0.001%/°C) | |
| D206 | †152-124 | Zener | 1N938A | (0.001%/°C) | |
| D214 | †152-124 | Zener | 1N938A | (0.001%/°C) | |

Connectors

| | | |
|------|---------|-------------------------------------|
| J190 | 131-106 | Chassis Mt., 1 Contact, Female, BNC |
| J259 | 131-274 | Chassis Mt., Insulated, BNC |

Transistors

| | | |
|------|----------|----------------------|
| Q115 | *151-127 | Selected from 2N2369 |
| Q125 | *151-127 | Selected from 2N2369 |
| Q134 | 151-097 | 2N955 |
| Q144 | 151-107 | 2N967 |
| Q164 | *151-127 | Selected from 2N2369 |
| Q174 | *151-127 | Selected from 2N2369 |
| Q194 | *151-127 | Selected from 2N2369 |

Resistors

Resistors are fixed, composition, $\pm 10\%$ unless otherwise indicated.

| | | | | | |
|------|---------|---------------|-------|-----|-------------|
| R111 | 315-102 | 1 k | 1/4 w | | 5% |
| R113 | 301-223 | 22 k | 1/2 w | | 5% |
| R114 | 315-101 | 100 Ω | 1/4 w | | 5% |
| R115 | 315-131 | 130 Ω | 1/4 w | | 5% |
| R117 | 315-273 | 27 k | 1/4 w | | 5% |
| R119 | 316-220 | 22 Ω | 1/4 w | | |
| R121 | 315-102 | 1 k | 1/4 w | | 5% |
| R123 | 301-223 | 22 k | 1/2 w | | 5% |
| R124 | 302-102 | 1 k | 1/2 w | | |
| R125 | 315-181 | 180 Ω | 1/4 w | | 5% |
| R127 | 315-273 | 27 k | 1/4 w | | 5% |
| R130 | 322-189 | 909 Ω | 1/4 w | | Prec 1% |
| R133 | 321-068 | 49.9 Ω | 1/8 w | | Prec 1% |
| R135 | 311-007 | 2 x 1 k | 2 w | Var | MAG (Pulse) |
| R136 | 321-101 | 110 Ω | 1/8 w | | Prec 1% |
| R140 | 322-189 | 909 Ω | 1/4 w | | Prec 1% |
| R143 | 321-068 | 49.9 Ω | 1/8 w | | Prec 1% |
| R148 | 322-222 | 2 k | 1/4 w | | Prec 1% |
| R150 | 311-007 | 2 x 1 k | 2 w | Var | POSITION |
| R152 | 315-362 | 3.6 k | 1/4 w | | 5% |

†Temperature Compensated.

Resistors (Cont'd)

| Ckt. No. | Tektronix Part No. | | Description | | S/N Range |
|----------|--------------------|----------------|-------------|------|-------------|
| R153 | 315-242 | 2.4 k | 1/4 w | | 5% |
| R155 | 315-122 | 1.2 k | 1/4 w | | 5% |
| R158 | 322-222 | 2 k | 1/4 w | Prec | 1% |
| R161 | 323-607 | 600 Ω | 1/2 w | Prec | 1% |
| R162 | 315-362 | 3.6 k | 1/4 w | | 5% |
| R163 | 315-242 | 2.4 k | 1/4 w | | 5% |
| R164 | 321-115 | 154 Ω | 1/8 w | Prec | 1% |
| R165 | 315-122 | 1.2 k | 1/4 w | | 5% |
| R167 | 322-094 | 93.1 Ω | 1/4 w | Prec | 1% |
| R170 | 302-102 | 1 k | 1/2 w | | |
| R171 | 323-607 | 600 Ω | 1/2 w | Prec | 1% |
| R174 | 321-115 | 154 Ω | 1/8 w | Prec | 1% |
| R176 | 321-083 | 71.5 Ω | 1/8 w | Prec | 1% |
| R177 | 322-094 | 93.1 Ω | 1/4 w | Prec | 1% |
| R182 | 323-685 | 52.7 k | 1/2 w | Prec | 1/4% |
| R183 | 323-682 | 195.7 Ω | 1/2 w | Prec | 1/4% |
| R185 | 323-683 | 1.86 k | 1/2 w | Prec | 1/4% |
| R186 | 323-684 | 1.928 k | 1/2 w | Prec | 1/4% |
| R190 | 302-105 | 1 meg | 1/2 w | | |
| R191 | 311-005 | 500 Ω | 2 w | Var | ATTEN |
| R192 | 316-561 | 560 Ω | 1/4 w | | |
| R194 | 316-102 | 1 k | 1/4 w | | |
| R195 | 315-202 | 2 k | 1/4 w | | 5% |
| R197 | 302-331 | 330 Ω | 1/2 w | | |
| R199 | 315-101 | 100 Ω | 1/4 w | | 5% |
| R201 | 308-092 | 4.5 k | 5 w | WW | 5% |
| R202 | 308-322 | 970 Ω | 1/2 w | WW | 1% |
| R204 | 308-185 | 7 k | 1/2 w | WW | 1% |
| R206 | 308-226 | 10 k | 1/2 w | WW | 1% |
| R208 | 311-488 | 10 k | 4 w | Var | —SUPPLY REF |
| R214 | 308-185 | 7 k | 1/2 w | WW | 1% |
| R215 | 308-185 | 7 k | 1/2 w | WW | 1% |
| R216 | 308-226 | 10 k | 1/2 w | WW | 1% |
| R218 | 311-488 | 10 k | 4 w | Var | +SUPPLY REF |
| R220 | 311-490 | 50 k | 2 w | Var | —75 V CALIB |
| R222 | 323-276 | 7.32 k | 1/2 w | Prec | 1% |
| R225 | 323-498 | 1.5 meg | 1/2 w | Prec | 1% |
| R227 | 308-327 | 41.6 k | 1/2 w | WW | 1% |
| R230 | 311-489 | 15 k | 2 w | Var | —15 V CALIB |
| R232 | 323-328 | 25.5 k | 1/2 w | Prec | 1% |
| R235 | 322-610 | 500 k | 1/4 w | Prec | 1% |
| R237 | 308-325 | 8.32 k | 1/2 w | WW | 1% |
| R240 | 311-489 | 15 k | 2 w | Var | +15 V CALIB |
| R242 | 308-325 | 8.32 k | 1/2 w | WW | 1% |
| R245 | 322-610 | 500 k | 1/2 w | Prec | 1% |

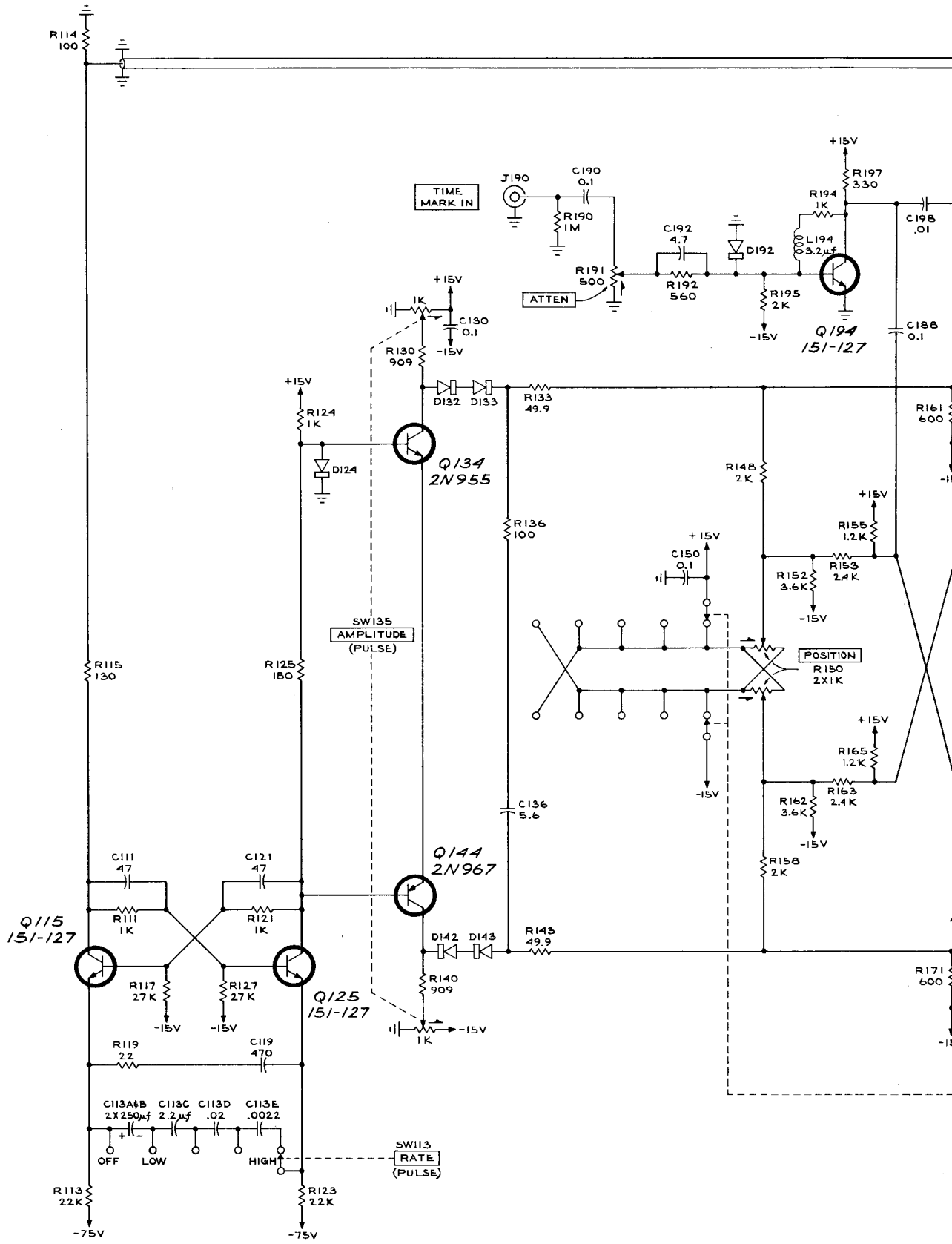

TYPE 10/11 M1 TEST UNIT

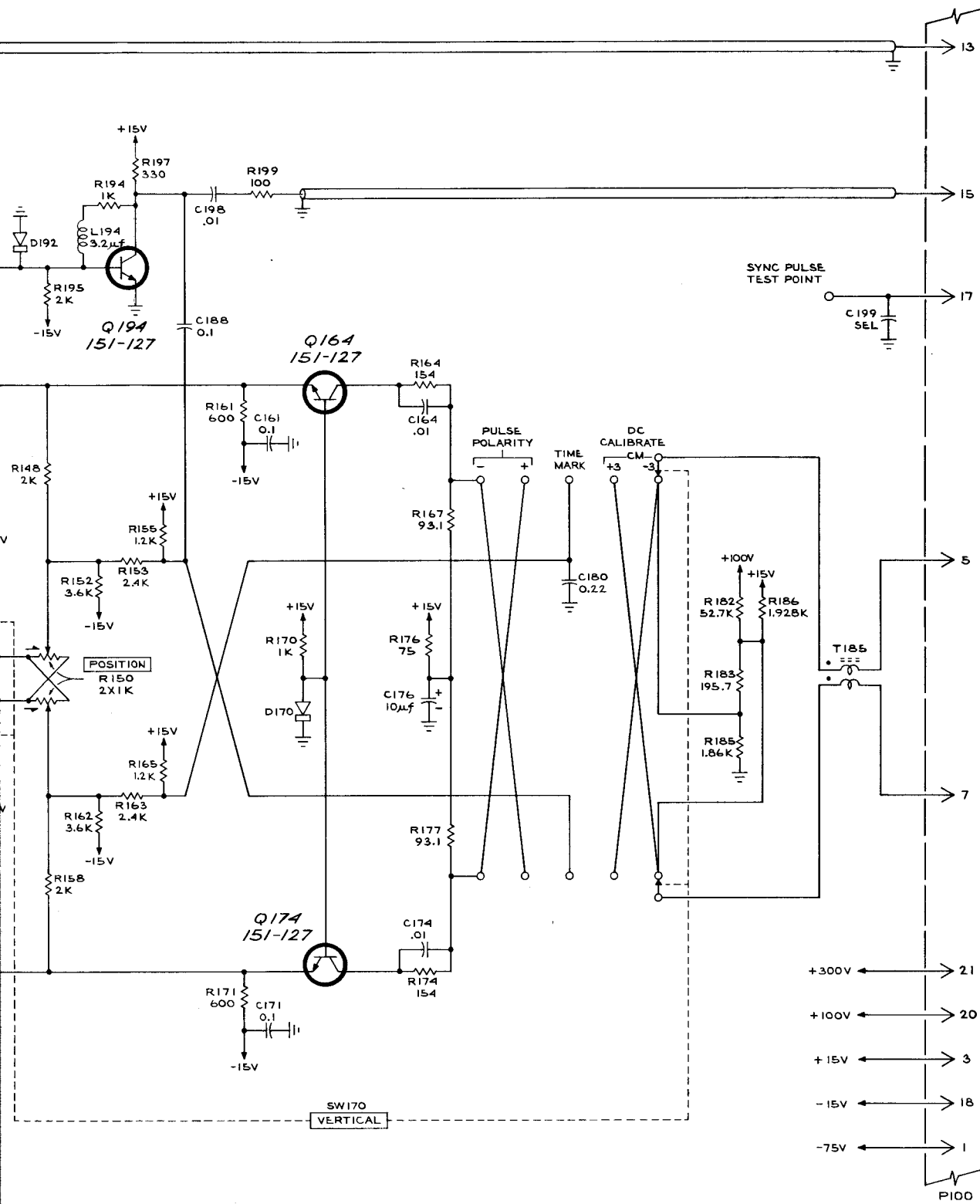

CMD
664

PULSER CIRCUIT

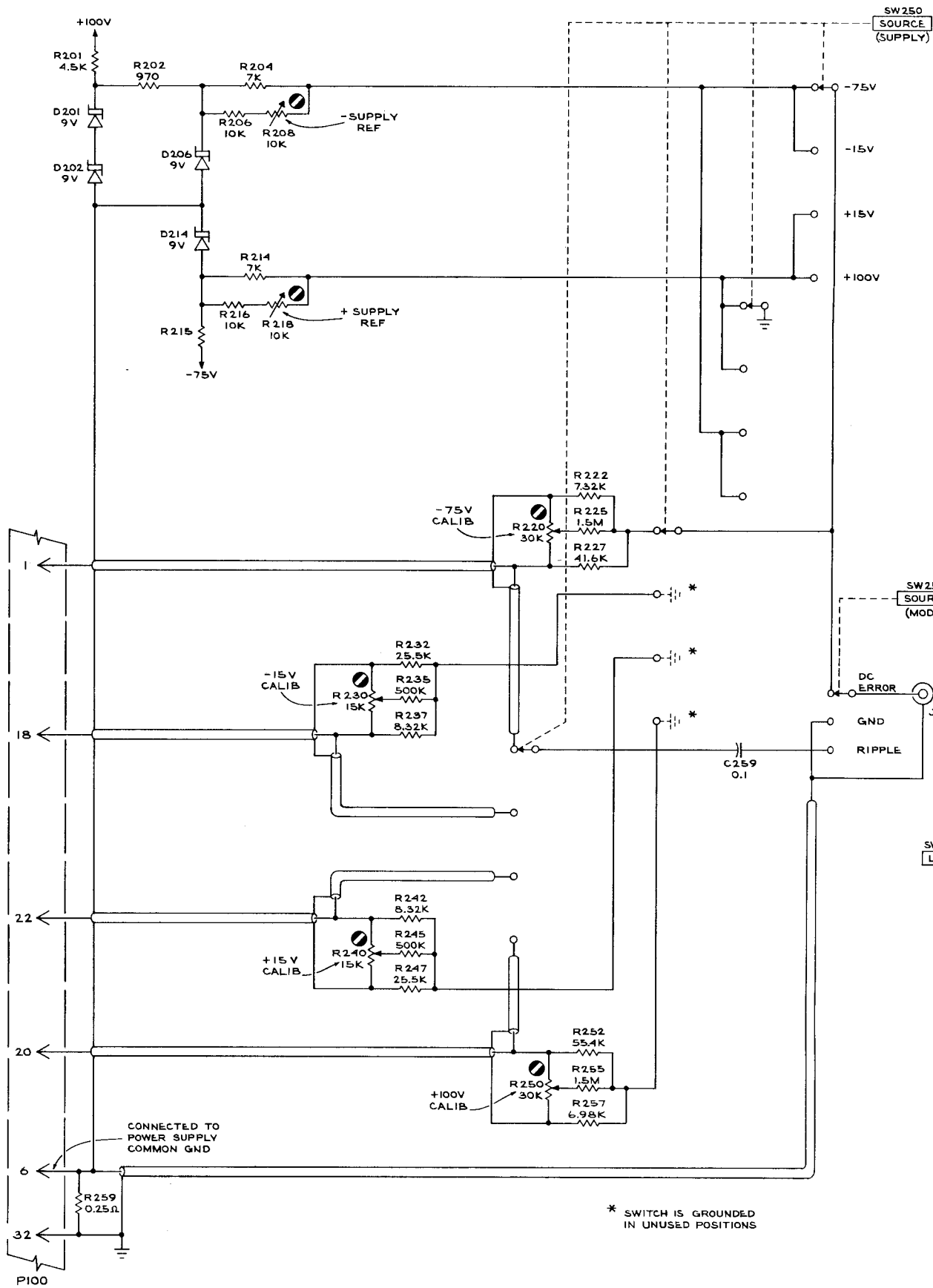

TYPE 10/11 MI TEST UNIT

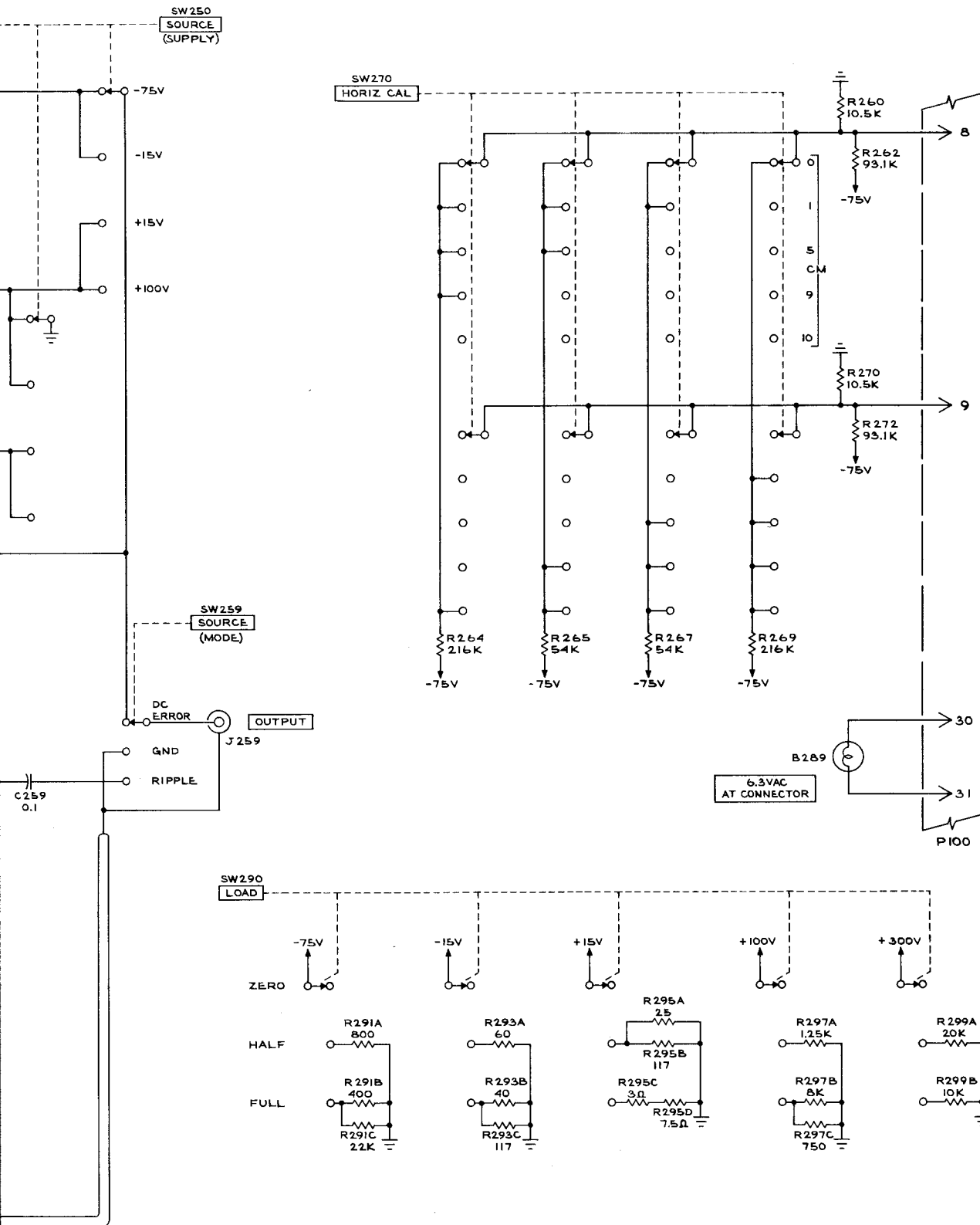

ROUNDED
POSITIONS

CMD
664

POWER SUPPLY & HORIZONTAL CALIBRATION

A

MANUAL CHANGE INFORMATION

At Tektronix, we continually strive to keep up with latest electronic developments by adding circuit and component improvements to our instruments as soon as they are developed and tested.

Sometimes, due to printing and shipping requirements, we can't get these changes immediately into printed manuals. Hence, your manual may contain new change information on following pages. If it does not, your manual is correct as printed.