

Remote Shunt Calibration

It is common knowledge - or at least it should be - that shunt calibrating a remote bridge arm at the instrument binding posts will introduce a calibration error several times greater than the error anticipated from leadwire desensitization considerations alone. What probably is not common knowledge is that the indicated calibration magnitude will be increased, not decreased, as expected from desensitization considerations. The significant point is that if a remote bridge arm is shunt calibrated at the instrument terminals and attempts are made to mathematically or experimentally adjust gage factor or instrument gain to correct the error, the sensitivity will be adjusted in the wrong direction and increase the error. Worse, perhaps, is that this is an "unsafe" error, in that output from the transducer being used is larger than the instrument indicates.

To illustrate the point, two examples are shown for strain gages: a quarter-bridge and a full-bridge (which could be any type of strain gaged transducer). In both cases, the gages (R_G) are 120 ohms and have a gage factor (K) of 2. The shunt value (R_{SH}) of 59 880 ohms is selected because it produces an indicator reading of 1000 microinch/inch when used with 120 ohm gages, and there is no lead resistance. For each example, the indicated calibration strain is listed for:

- calibration at the instrument terminals
- calibration at the bridge arm by use of dedicated calibration leads
- calibration directly across the bridge arm

Note that for high shunt values and reasonable lead resistances, (b) and (c) are equal. Further, for (c) - and (b), if the values are approximately the same - the error can be removed by adjusting the gage factor setting (i.e., gain) of the instrument.

QUARTER BRIDGE

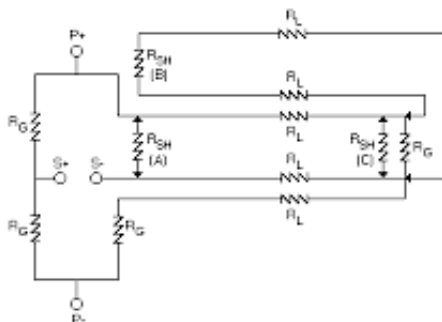

SHUNT POSITION INDICATED STRAIN

SHUNT POSITION INDICATED STRAIN	
A	1051 microstrain
B	985 microstrain
C	985 microstrain

FULL BRIDGE

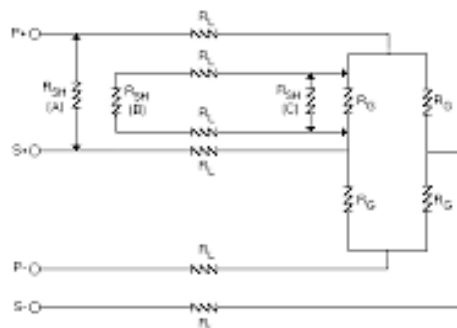

SHUNT POSITION INDICATED STRAIN

SHUNT POSITION INDICATED STRAIN	
A	1034 micRostrain
B	969 microstrain
C	969 microstrain

There really is no legitimate reason for shunting a remote bridge arm at the instrument terminals in quarter- and half-bridge operation, although it may seem convenient for indicating compressive strains. However, the practice is common with external full-bridges or strain gage transducers. The examples shown should serve to illustrate how great the errors can be if remote calibration is not used. Essentially all Micro-Measurements instruments provide remote calibration capability to eliminate the associated error. The leadwire resistances shown (R_L) are not exaggerated. Fifty feet of #26 AWG wire has a resistance of about 2 ohms.

In summary, terminal shunting of external bridge arms can cause significant errors that cannot be corrected simply by adjusting the instrument gain to show the expected value. It is a practice that should be avoided, and it is for this reason that Strain Smart Data Systems do not provide shunt calibration for an external full bridge.