

Authors: Yuval Hernik; Aaron Ram; Yosi Tzabari; Hero Faienstein
Tel: +972-54-300-0191 (Yuval Hernik)
E-mail: Yuval.Hernik@vishaypg.com; Aaron.Ram@vishaypg.com;
Yosi.Tzabari@vishaypg.com; Hero.Faienstein@vishaypg.com

Mirror, Mirror: What is the Trade-Off Between Price, Cost, and Risk, When Selecting a Precision Resistor?

Introduction:

The choice of components for every application involves tradeoffs. When it comes to resistors, several device technologies are available to designers and each of them makes sense for a certain subset of applications, depending on cost-benefit-risk analyses. But when the application requires initial accuracy, minimal change with temperature, stability over time and load, resistance to moisture, and a number of other characteristics, the choices are more limited.

The purchase price of each resistor technology generally falls along the lines of thick films being the least expensive, thin films being more costly, and bulk metal foil being more costly yet. But as we all know, purchase price and “cost of usage” are two very different matters.

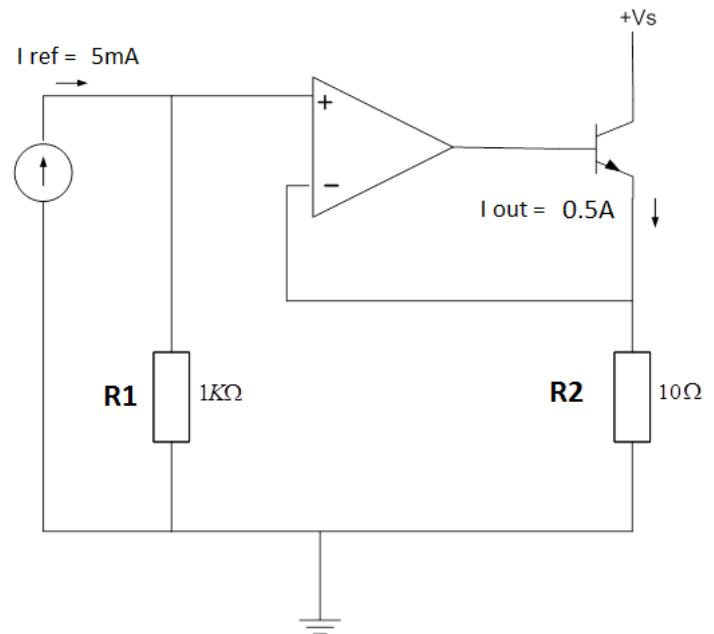

Figure 1: Current Mirror Circuit

The inexpensive device that shifts in value or catastrophically fails can wind up costing many times more in terms of replacement costs before shipment, failures in operating systems after shipments, scrubbed missions, and future business.

In some cases, the least expensive alternative is perfectly adequate. For example, digital systems process pulses that represent the presence or absence of a signal. It does not matter if the signal varies by 10 or 20 percent; the system just wants to detect if a signal is present or not. This is a perfect application for thick film resistors. Thick films are also appropriate for non-precision, general application circuits common to many consumer electronics systems. In these situations, a thick film resistor is both effective and economical.

Thin film resistors are more precise and stable when their temperature changes rather than thick film resistors. They are also more costly. This technology is best suited for applications requiring greater

Vishay Precision Group

3 Great Valley Parkway, Suite 150 • Malvern, PA • USA • Phone +1-484-321-5300 • Fax +1-484-321-5301

precision, as in analog circuits where the stability of specific values is important, rather than just the mere presence or absence of a signal. Here, the designer makes both economical and performance analyses and determines that the requirements for precision and stability are satisfied by the more-costly thin films with acceptable risk and consequences of failure for the application.

In some applications, however, the consequences of degradation of performance or total malfunction are so costly that only the use of very high precision, very high reliability resistors can be justified. These are the applications that demand Bulk Metal® Foil resistors. Telemetry equipment in remote earth locations may be extremely expensive to access and repair, and lives could be lost if the signal goes down. Systems in space must work as required with the greatest degree of confidence; there is no replacement opportunity and the cost of getting the system into operating locations is astronomical.

Aviation and aerospace continually put human lives at risk. Automatic test equipment performing hundreds of almost instantaneous tests on semiconductors as they come off the production line must perform with speed, precision and reliability or hundreds of thousands of dollars' worth of materials could be lost. Medical equipment cannot give false or undependable readings and still safeguard people's health and lives. Such applications require the high precision and high reliability of foil resistors.

The choice of resistor technology often depends on the designer's view of the overall error budget. The designer may choose to use less than the full deviation error budget if the equipment will never see full-scale stress conditions. For example, a laboratory instrument that is expected to be permanently installed in an air-conditioned laboratory does not need an end-of-life allowance for ambient temperature excursions.

But there are other reasons for tolerancing the resistors tighter than the initial calculation. Measurement equipment accuracy is traditionally 10 times better than the expected accuracy of the devices under test, so these tighter tolerance applications require a foil resistor. Also, the resistor without any stress factor considerations at all will still experience a base-level shift over time that must be considered. Foil resistors have the least amount of shift over time. The equipment manufacturer's recommended recalibration cycle is a factor in the marketability of his product and the longer the cycle, the more acceptable the product. Foil resistors contribute significantly to longer calibration intervals.

Since the stress levels of each application are different, the designer must make an estimation of what the level of stress might be and assign a stress factor to each one in terms of anticipated resistance shift. In some applications the operating stress level might be low, but the non-operating stress levels can still be high. For example, if the resistor is installed in a piece of equipment that is expected to go out into an oil field in the back of a pickup truck, then shock, vibration, rain, subarctic cold, or heat from the sun are obvious factors.

Industry standards for shock and vibration are based on the robustness of end products considered as the sum of their parts, and the threshold is what the most susceptible part can withstand. Above and beyond the industry standard, individual part specifications may include higher levels of shock and vibration sustainability. This applies to jet aircraft, truck-, tank-, and ship-mounted military equipment, air-drop emergency equipment, missiles, and so on.

Another aspect that should be reviewed is post manufacturing operations (PMOs). Vishay Foil Resistors has developed PMOs that are uniquely applicable to Bulk Metal Foil resistors and take stability one step further. The PMO was first established a few decades ago when the demands from the military and space applications was for production methods that would minimize resistor drift after launch into outer space. The PMO today combines two elements: short time overload and accelerated load life. The PMO should only be considered when the level of stability required is beyond the published limits for standard products.

End Product: High Stability Current Mirror Circuit

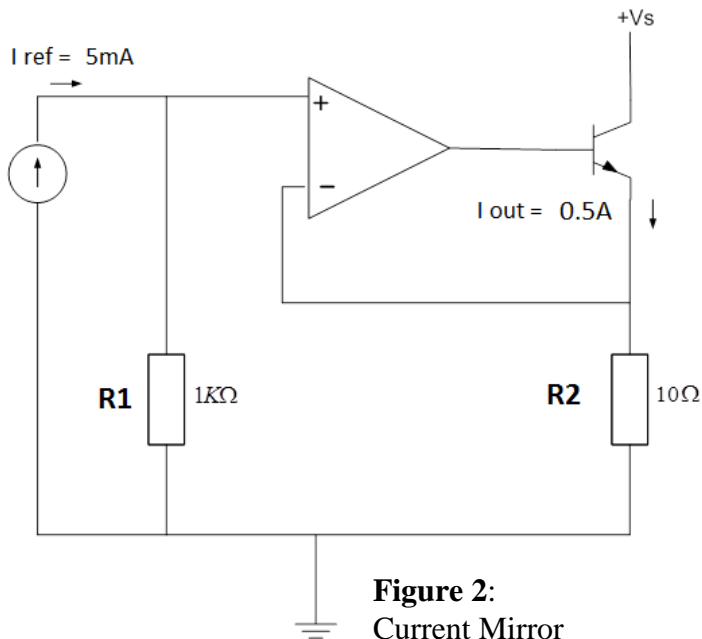

VHP4Z

Figure 3: Image of VHP4Z Hermetically Sealed Power Resistor

The function of the current mirror circuit is to duplicate, attenuate, or amplify a specific current source or current signal in such a way that the output current is identical to the input but just scaled by a constant gain ratio: A . In the case of a ratio, $A = 1$, the circuit behaves like a buffer. When the gain is less than 1, the circuit performs as an attenuator, and when the gain is greater than 1, the circuit performs as an amplifier.

In the circuit shown, a current signal (I_{ref} , which is passed through R_1) is input to the current mirror. The output signal, in an ideal situation, will be the exact same signal except scaled by the gain ratio $A = R_1/R_2$. The ratio of R_1/R_2 must remain constant throughout the operation of the product for this circuit to give the most accurate reproduction of I_{ref} . When the gain ratio A changes because of resistance changes due to the effects of temperature, operating time, operating power, or other environmental conditions such as humidity, the output current, I_{out} , will change as well even if I_{ref} remains constant. The unwanted distortions of the original signal can be called noise, drift, or various other terms for error.

In the case of the example above with gain ratio of 100, in order to balance the input voltages of the op amp, a relatively large current (500mA, 2.5W) is supplied to R_2 when the input current is 5mA. In this case R_2 may become very hot due to self-heating, which means that various changes of the sensed voltage are experienced due to temperature coefficient of resistance, power coefficient of resistance, thermal EMF generation, and current noise.

An example of a non-standard solution for this circuit is given below. Two resistors are assembled inside a hermetically sealed power resistor package known as the VHP4Z to assure the stability of R_1/R_2 . The output terminals have been configured to behave like a voltage divider. This takes advantage of the self-heating of one resistor to bring the other resistor to the same temperature resulting in an identical response to maintain the ratio. The Z-foil product was selected for its very low TCR to negate changes due to ambient temperature and for its low power coefficient of resistance (PCR) to reduce ratio changes when power is suddenly applied. Additionally, the package is hermetically sealed to prevent unwanted effects of moisture

and oxidation on the resistors over very long periods of time and its materials are compatible with copper PCB traces to minimize thermal EMF generation. Finally, a series of post-manufacturing operations (PMO) are performed on the units to condition the resistors R1 and R2 for the lowest possible shift when working power is applied, 25mW and 2.5W respectively.

This extremely stable voltage divider allows circuit designers to achieve previously unmatched levels of stability utilizing this type of current mirror without requiring a combination of multiple components.

| | | | | | | | |
|------|-------------|----|------|---|----|---------------------------------|-----------|
| REV. | DESCRIPTION | BY | DATE | THIS DOCUMENT CONTAINS CONFIDENTIAL INFORMATION OF VISHAY RESISTOR PRODUCTS. THE RECIPIENT SHALL NOT REPRODUCE, USE, OR TRANSMIT THIS DOCUMENT OR INFORMATION FOR ANY PURPOSE, WITHOUT WRITTEN PERMISSION OF VISHAY RESISTOR PRODUCTS AND AGREES TO SURRENDER SAME TO VISHAY RESISTOR PRODUCTS UPON DEMAND. | A- | Your V/N Number Here | REV. - |
|------|-------------|----|------|---|----|---------------------------------|-----------|

ELECTRICAL SPECIFICATIONS

| Type | # of Res. | Values | Tolerance of Each R | Operating Power (Current) (Mounted on Heat Sink) | Matched Tolerance Between Resistors (Ratio Tolerance) | Temperature Coefficient of Resistance (TCR) 25C +/- 5°C | TCR Tracking 25C +/- 5°C |
|------------------------------------|-----------|---------------------|---------------------------|---|---|--|-----------------------------|
| VHP4Z Divider Special Construction | 2 | R1 = 1K R2 = 10R | R1 = 0.005% R2 = 0.01% | R1 = 25mW (5mA) R2 = 2.5W (0.5A) | R1:R2 = .05% | 1 ppm/°C | 1 ppm/°C |

Stability treatment PMO added to guarantee lowest shift under long term powered-on operation

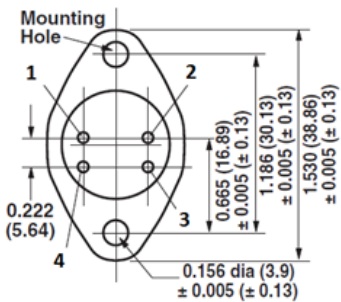

Standard Marking Arrangement

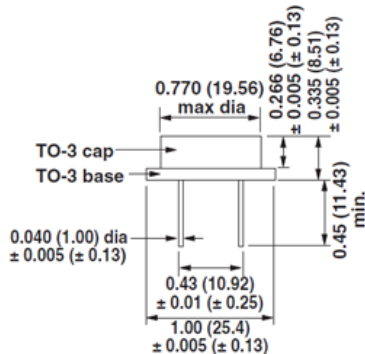
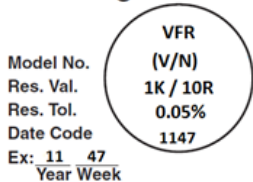

| | | | |
|---|------------|---|-----------|
|  | | Vishay Precision Foil Inc. 3 Great Valley Parkway, Suite 150 Malvern PA, 19355 | |
| TITLE | | | |
| VHP4Z resistor in a high power voltage divider configuration – narrow ambient temperature range | | | |
| CUSTOMER: | | Your Company Name Here | |
| DRAWN BY | DATE | APPROVED BY | DATE |
| A.R | 11/28/2011 | | |
| scale | A- | Your V/N Number Here | REV. - |
| | | PAGE 1 OF 1 | |

Figure 4: Example of a Vishay Precision Group Non-Standard Resistor Specification for Optimal Performance in a Unique Application

Summary:

Different applications require different resistor technologies; whatever the application, some form of price or performance tradeoff is always involved. An effective price-cost-benefit-risk analysis must be conducted for each application to assure selection of the appropriate resistor for the application. The basis for such an analysis is a thorough understanding of the performance characteristics and reliability implications of each technology in each application.

Further information about other Vishay Foil Resistors products is available on our website: www.vishayfoilresistors.com. Follow Vishay Foil Resistors at <http://www.twitter.com/FoilResistor> for the latest news.