

Author: Yuval Hernik

Tel: +972-3-557-0852

E-mail: Yuval.Hernik@vishaypg.com

Component Selection and Layout Strategies for Avoiding Thermal EMF Noise

Introduction:

The ever smaller form factors of electronic systems and components have brought countless benefits to users, but at the same time they greatly complicate the electronic design process. While reducing component size might reduce the thermal gradients across any particular component, the closer proximity of components and the greater concentration of heat creates new thermal management problems and subjects the circuits to greater probability of circuit errors due to thermal electromotive force (thermal EMF).

When designing a low-level DC circuit, we must keep the influence of noise sources to minimum. The externally induced sources are EMI and RFI. There are also several internally generated noises. Some of these are Johnson noise, current noise, Shot noise, and popcorn noise. There are also vibration-induced EMF, triboelectric and electrostatic noises.

In 1821, Thomas Seebeck discovered that when two wires made of dissimilar metals are joined at both ends and the opposing junctions thus created are maintained at different temperatures, a current will flow through the loop (see Fig. 1). The magnitude of this current is proportional to three factors:

1. The temperature difference between the junctions at the two ends
2. Seebeck coefficients (proportionality measures based on different metals of the two wire materials)
3. The loop resistance

If one end of the loop is opened and a voltmeter is attached to the two wires (Fig. 2), with the newly created meter-to-wire junctions kept at the same temperature as before, a voltage can be read on the voltmeter. This voltage is proportional to the temperature difference at the two ends of the wires and to the difference between the Seebeck coefficients of the two wire materials. Because the meter has practically an infinite input resistance, no current flows in the circuit and therefore produces no voltage drop in the wires, and the loop resistance is no longer a factor.

This is the basic principle of operation for thermocouple thermometers. The meter side junctions are kept at a fixed reference temperature (usually 0°C by an ice bath or an electronic circuit simulating zero degree conditions) and the other end is at the heat source.

The Seebeck coefficient is also called “thermal electromotive force coefficient” or simply thermal EMF coefficient.

Vishay Precision Group

3 Great Valley Parkway, Suite 150 • Malvern, PA • USA • Phone +1-484-321-5300 • Fax +1-484-321-5301

Figure 1:

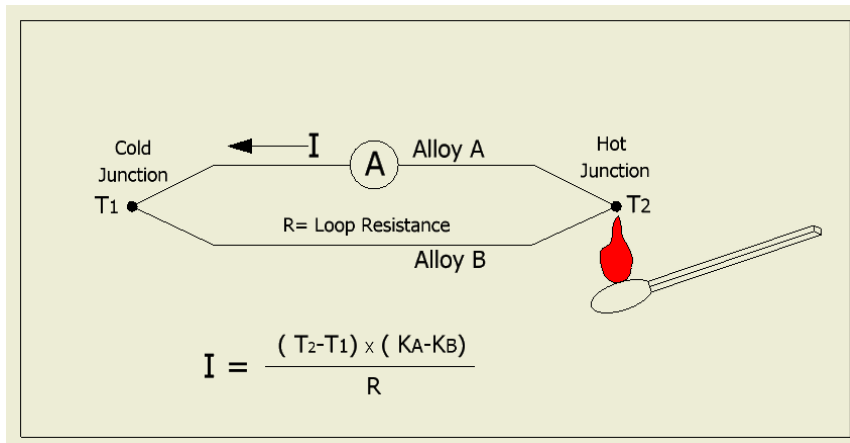
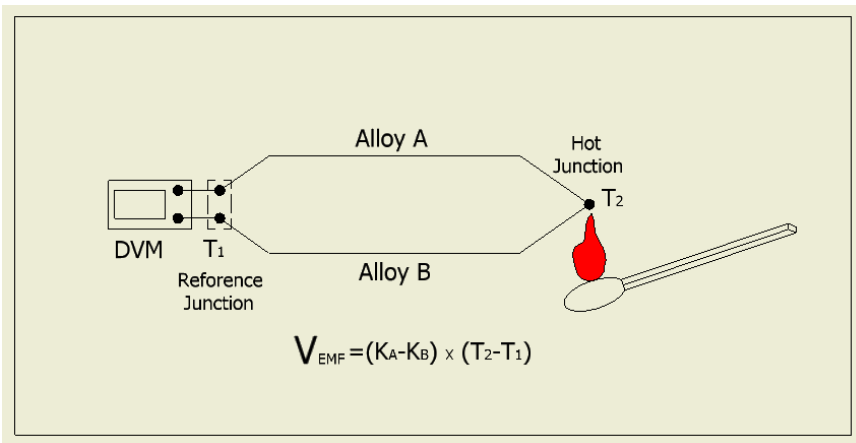

Figure 2:



Because it is very difficult to predict the thermal EMF coefficient of an alloy from its element composition, all the values for materials commonly used are obtained by measurement. Measurements are made by fixing the material of one of the elements to a common metal such as platinum or copper. Thus the thermal EMF coefficient for each metal is stated as referenced to the same reference metal.

All thermal EMF coefficients are temperature dependent. The numbers given are averages between 0 °C and 100 °C. Except for very demanding applications, the small error generated by these averages is negligible.

The unit of thermal EMF referring to copper or platinum is microVolt/°C. When the value of thermal EMF for a material referred to platinum is known, the value referred to copper can be calculated. This is done by subtracting the thermal EMF value for copper vs. platinum (7.6µV/°C) from the platinum value. Similarly, the thermal EMF between any two metals can be found just by subtracting their individual thermal EMFs referenced against copper.

Original release: April 14, 2010

Design Considerations

A host of metals, alloys, and metal composite conductors are used in electronic components. Some of these, such as resistors and semiconductors, generate internal heat (which is known as self-heating or the Joule effect) Therefore it is very difficult to avoid thermal EMF generation in electronic circuits. However, good results can be achieved when the designer pays close attention to material and component selection, thermal management of the critical areas, and proper circuit layout.

Another way of looking at thermal EMF is to imagine small batteries in series with every component. The battery voltage would be proportional to the temperature across the metal junction and the thermal EMF coefficient.

The following are a few points to keep in mind when designing a low-level DC signal processing electronic circuits:

1. Nearly 30 times more heat will be transmitted by the thin copper of a printed circuit board than by the glass-epoxy board itself.
2. In low thermal EMF D.C circuit designs it is crucial to keep all junctions at the same temperature. This means designing the low-level and sensitive areas of the circuit in an isothermal island, where the temperature is kept even over the entire area. It is as important to reduce the heat flowing into a junction as it is to reduce heat flowing out. Heat can flow into or out of a junction in three ways. First, by conduction through the copper or the component leads or terminations. Second, by radiation from a hot component nearby. Third, from forced or natural air convection within the housing.
3. As much as possible, designers should use low thermal EMF generating materials and components.

Because of the close thermal expansion match of the Kovar alloy to glass, many electronic components are sealed using glass seams or eyelets with Kovar terminations leading to the outside. All hermetic package leads are made from Kovar or from something very similar. Unfortunately, the thermal EMF coefficient of Kovar against copper is one of the highest among the alloys used in electronics ($-35\mu\text{V}/^\circ\text{C}$).

For example, an operational amplifier is used in a circuit with gain of 100 to amplify a 1mV signal. This amplifier is mounted on a printed circuit board along with its resistor network and other components.

If the circuit is not properly laid out, there will be temperature difference at the input terminals of the op amp. This causes an error of more than 0.5% of the 100mV output signal

The leads or the terminations of precision components should be made from specific alloys which have sufficiently low and inconsequential thermal EMF.

Often the bad layout of the circuit is to blame for output drifts rather than the amplifiers or the components.

4. Internally generated heat must be properly dissipated.

Original release: April 14, 2010

Since there are at least two interconnections inside the component, any thermal gradient within the component itself will generate an internal thermal EMF voltage. Designers should avoid anything that will cause thermal gradients in a component.

Thermal gradients can also be caused by the improper dissipation of internally generated heat from the component.

Some manufacturers provide good internal thermal EMF design. For example, the internal thermal EMF of Bulk Metal® Foil resistors is specified to be less than $0.1\mu\text{V}/^\circ\text{C}$.

5. Avoid convection and radiation heating effects.
It is always a good idea to shield or keep low-level D.C circuits away from high-power areas. A cooling fan can heat an area as well as cool it because of the way air convection currents set up within the electronic package.
6. Use the best resistors or resistor networks.
Bulk Metal® Foil resistors always perform the best in low-level D.C circuits, due to their construction and their copper leads (for through-hole version and SMD current sense). In addition to excellent thermal EMF properties, Bulk Metal® Foil resistor networks exhibit very tight TCR tracking and uniform long-term ratio aging. Also, Vishay Foil Resistors have extremely low absolute TCR ($\leq 0.2\text{ppm}/^\circ\text{C}$) and long term stability ($50\text{ppm } \Delta R$ at 70°C , 10,000 hours). Another benefit of Vishay Foil Resistors' networks is that thermal and electrical parameters can be optimized with customized designs for tight matching and frequency response.
7. Use low power consuming components in low level D.C circuits.
Low power consuming op amps and higher resistance voltage dividers always work better in low level circuits.
8. Understand the sources of thermal EMF in resistors.

In resistors, since leads or terminations are usually made from a material which is different than the resistive material, thermal EMFs are created by external sources of heat, or by heat generated when power is applied to a resistor, or by both effects.

In a resistor comprised of two leads or terminations to a resistive element, the polarities of the thermal EMFs at either end of the resistor are opposing. If the ends are at different temperatures, an error voltage is generated and the DC circuit is affected.

- If the two points on the printed circuit board, where the resistor leads or terminations are connected, are at different temperatures, the heat flow through the resistor will create temperature gradients inside the resistor. As a consequence, a differential thermal EMF will be created. Its magnitude will depend on the materials used, the construction of the resistor, and the temperature difference between the leads or terminations ΔT .
- The resistor's internal connections can also see different temperatures due to other external sources of heat, such as radiation from neighboring devices or air currents. The magnitude of the above effects is expressed in microvolts per degree centigrade.

Original release: April 14, 2010

- Another source of thermal EMF is the heat generated when power is applied to a resistor. Due to the dissymmetry of power distribution over the resistor surface and dissymmetry in heat conducting paths, the internal joints will see different temperatures, giving rise to thermal EMF. In this case, the magnitude will depend on power applied and is expressed in microvolts for a given power level.

Of course, the three cases are additive.

Bulk Metal® Foil resistors, based on a unique process and internal construction, can be used to reduce thermal EMF in any circuit.

Thermal EMF Results for Four Different Technologies:

Vishay Foil Resistors: CSM Series (5µV), Thick Film (40µV), Metal Strip vendor #1 (35µV), Metal Strip vendor #2 (>60µV)

Ambient Δtemperature: about 8°C

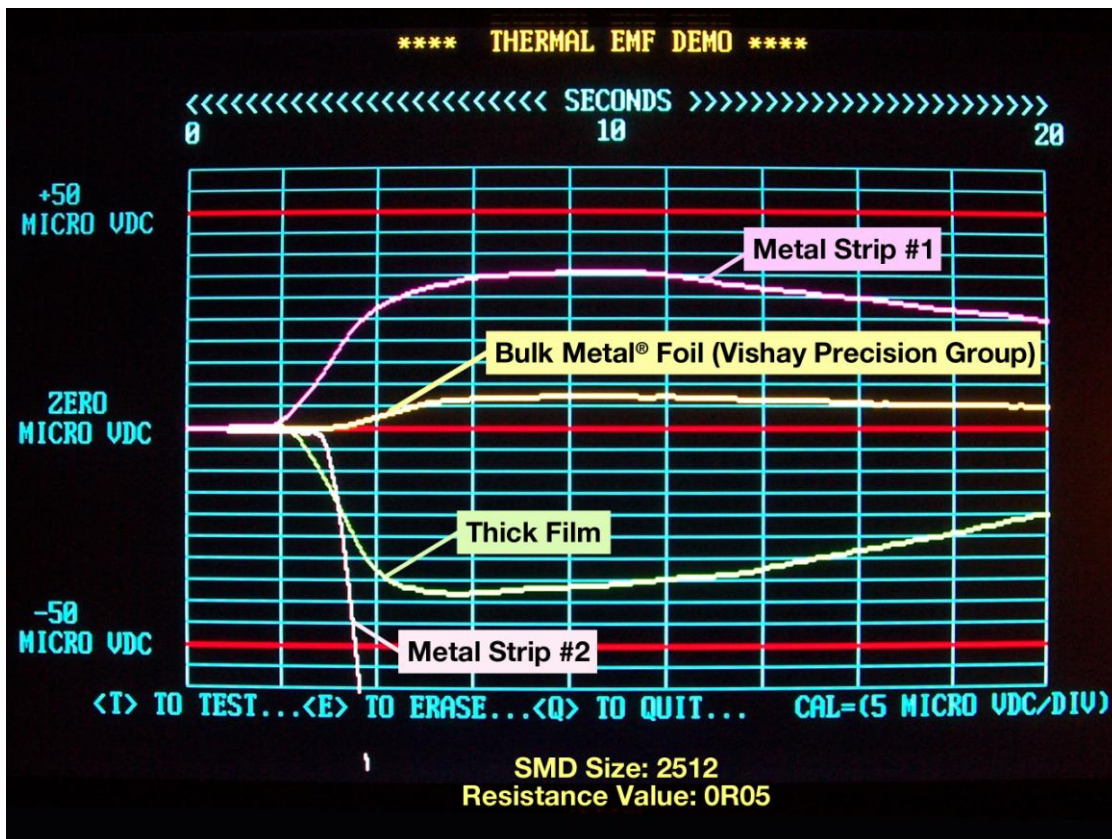

Note: S102C/K and Z201, Z203 resistors have a thermal EMF of 0.1µV/°C

Original release: April 14, 2010

Conclusions:

To achieve the optimum results in analog circuit designs from a thermal EMF point of view:

1. Take advantage of infinite resolution and stability (temperature and mechanical) of low ohmic values to use the foil trimmer in series with the resistor to be adjusted (rheostat applications).
2. Designers should locate DC circuits in an area of most constant temperature.
3. Try to use low thermal EMF components, such as Bulk Metal® Foil resistors.
4. Dissipate the internal heat of the component in a way to reduce thermal gradients.
5. Avoid convection and radiation effects in DC areas.
6. Use low power consuming components.
7. Take advantage of the high thermal conductivity of the PCB copper by forming thermal bridges in critical areas.

For more information about this product group, please contact us at: Foil@vishaypg.com.

Follow Vishay Foil Resistors on Twitter: [@VPGFoil](https://twitter.com/VPGFoil) or “Like” our Vishay Precision Group fan page on [Facebook](https://www.facebook.com/VishayPrecisionGroup).