



**VISHAY
PRECISION
GROUP**

BLH

**LCp-100/200R
Remote Digital Display Units
Operator's Manual**

NOTICE

BLH makes no representation or warranties of any kind whatsoever with respect to the contents hereof and specifically disclaims any implied warranties or merchantability or fitness for any particular purpose. BLH shall not be held liable for errors contained herein or for incidental or consequential damages in connection with the furnishing, performance, or use of this publication or its contents.

BLH reserves the right to revise this manual at any time and to make changes in the contents hereof without obligation to notify any person of such revision or changes.

Call (781) 298-2216 for BLH Field Service

Table of Contents

SECTION 1.	Introduction.....	1-1
1.1	PRODUCT DESCRIPTION.....	1-1
1.2	MOUNTING OPTIONS	1-1
1.3	SPECIFICATIONS	1-2
1.4	WARRANTY POUCY	1-2
1.5	FIELD ENGINEERING	1-1
SECTION 2.	Installation	2-1
2.1	INTRODUCTION.....	2-1
2.2	MOUNTING.....	2-1
2.2.1	Standard Unit Mounting.....	2-1
2.2.2	Optional NEMA 414X Enclosures	2-1
2.3	ELECTRICAL CONNECTIONS	2-3
2.3.1	The Remote Display Rear Panel.....	2-3
2.3.2	Mains (ac) Power	2-3
2.3.3	Serial Communication	2-3
2.4	INTRODUCTION.....	2-4
2.5	FRONT PANEL DISPLAY STATUS	2-4
2.5.1	Display Mode.....	2-4
2.5.2	Display Control	2-4
2.5.3	Zero and Tare Functions.....	2-4
2.6	COMMUNICATION CONFIGURATION.....	2-4
SECTION 3.	Operation.....	3-1
3.1	DISPLAY OPERATION.....	3-1
3.2	REMOTE CONTROL FUNCTIONS	3-1

SECTION 1. Introduction

1.1 PRODUCT DESCRIPTION

BLH Remote Digital Displays (Figure 1-1, 1-2) receive and display serial ASCII data transmitted by a BLH host LCp100, LCp-200, or Baldwin Model 2020 series weight indicator/ transmitter. Operating on supplied data, the Remote Display precisely duplicates the weight, rate*, or tension value display of the host device. Indication also includes gross, net, and level information. Figure 1-1 shows a typical Remote Digital Display application.

Units require only a twisted pair of wires for interconnection and mount up to 2000 feet from the host device. Remote Display units are ideally suited for applications where analog panel meter resolution is not adequate. Analog displays present only an approximation of actual weight data whereas serial communication guarantees digit-for-digit replication. Precision accuracy, easy installation, and optional NEMA or explosion-proof enclosures make these units the perfect choice for plant or control room remote display.

Front panel ZERO and TARE keys transmit push to zero and tare commands to the host device. The GIN (gross-net-rate) key, however, functions independently from the host device. For example, a remote LCp-200R unit can display net weight or rate while the host LCp-200 displays gross weight. CE Marked Remote Digital Displays have passed both the EU (European Union) Low Voltage and EMC Directives.

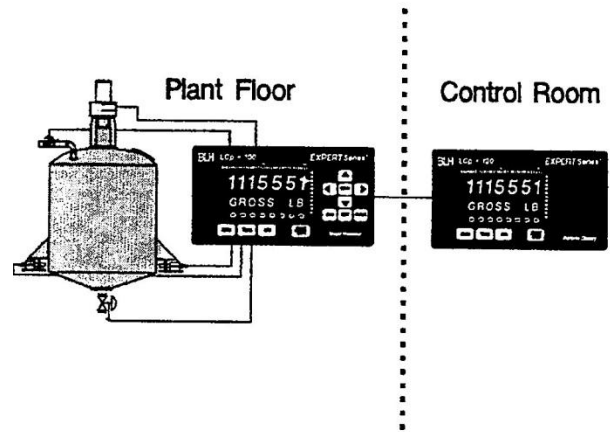

Figure 1-1. Typical Remote Display Application

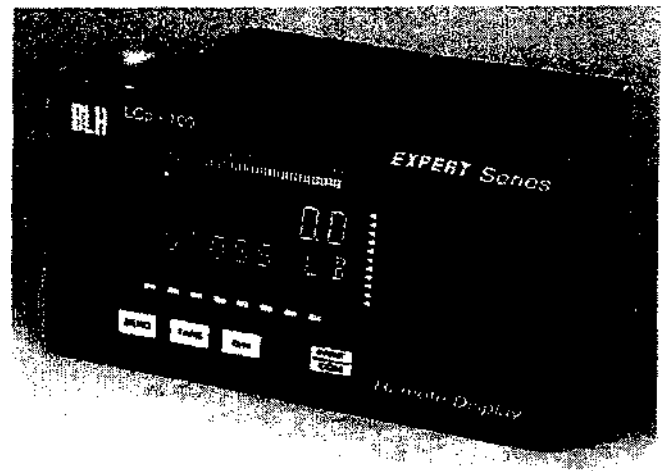

Figure 1-2. LCp-100R Remote Digital Display

1.2 MOUNTING OPTIONS

For units located in a general factory/plant floor, or if corrosive, hose down, or sanitary requirements are a factor, a NEMA 4X stainless steel enclosure is available. For Div. 2 hazardous locations, units are available with FM approval as a non-incendive device. For Division 1 hazardous locations an explosion proof enclosure is available.

1.3 SPECIFICATIONS

Display		Communications	
Type	high intensity cobalt green vacuum fluorescent	Serial RS-485	two-wire, half duplex
Active Digits	7 digit alpha-numeric 0.59" high for weight, 8 digit alpha-numeric 0.39 " high for stabs	Baud Rate	9600
Environment		Approvals/Certifications	
Operating Temp.	-10 to 55°C (15 to 131°F)	FM (Factory Mutual)	3611: (Mass I,II,III; Div.1,2; Groups A-G)
Storage Temp.	-20 to 85°C (-5 to 185°F)	CSA	C22.2: (Class I,II, III; Div.1,2; Groups A-G)
Humidity	5 to 90% rh non-condensing	IEC 801-2	ESD susceptibility, category B
Voltage	117/230 Vac +/-15% @ 50/60Hz	IEC 801-3	radiated electromagnetic field, cat. A
Power	15 watts maximum	IEC 801-4	conducted line transients, cat B
Parameter Storage	flash EPROM	EMI Emissions	FCC part 15 subpart B, Class A Canadian Dept. of Communication Class A
Enclosure		EN 5501	Grow 1, Class A
Dimensions Standard	4.63 x8.40 x 6.5 in. HWD	1EC 1010-1 /EN61010-1	Electrical Safety
NEMA Options	8.5 x 13.5 x 10.45 in. HWD	EN50082-1 1992	Susceptibility: subparts 801,2,3, and 4
Materials		EN55011	Emissions: Equipment Class I, Group A
Aluminum Case/Bezel	overlay meets 94V-O rating		

1.4 WARRANTY POUICY

BLH warrants the products covered hereby to be free from defects in material and workmanship. BLH's liability under this guarantee shall be limited to repairing or furnishing parts to replace, f.o.b. point of manufacture, any parts which, within three (3) years from date of shipment of said product(s) from BLH's plant, fail because of defective workmanship or material performed or furnished by BLH. As a condition hereof, such defects must be brought to BLH's attention for verification when first discovered, and the material or parts alleged to be defective shall be returned to BLH if requested. BLH shall not be liable for transportation or installation charges, for expenses of Buyer for repairs or replacements or for any damages from delay or loss of use for other indirect or consequential damages of any kind. BLH may use improved designs of the parts to be replaced. This guarantee shall

not apply to any material which shall have been repaired or altered outside of BLH's plant in any way, so as in BLH's judgment, to affect its strength, performance, or reliability, or to any defect due in any part to misuse, negligence, accident or any cause other than normal and reasonable use, nor shall it apply beyond their normal span of life to any materials whose normal span of life is shorter than the applicable period stated herein. In consideration of the forgoing guarantees, all implied warranties are waived by the Buyer, BLH does not guarantee quality of material or parts specified or furnished by Buyer, or by other parties designated by buyer, if not manufactured by BLH. If any modifications or repairs are made to this equipment without prior factory approval, the above warranty can become null and void.

1.5 FIELD ENGINEERING

Authorized BLH Field Service Engineers are available around the world to install LCp Remote Display systems and/or train factory personnel to do so. The field service department at BLH is the most important tool to *assure* the best performance from your application. Field service phone numbers are listed below.

Factory: (Main Number) (781) 821-2000

SECTION 2. Installation

2.1 INTRODUCTION

This chapter provides Remote Display mounting and electrical installation information. Instruments will operate accurately (to specification) in locations with temperatures ranging from -10 °C +55°C (+14°F to + 130°F). The installation location should be free of vibration. Unless equipped with the proper enclosure option, instruments should not be located in areas containing explosive or corrosive vapors. In all installations, ac (mains) power should be supplied from a clean (transient free) instrument power source.

2.2 MOUNTING

2.2.1 STANDARD UNIT MOUNTING

Standard Remote Display Units are shipped with the necessary hardware for panel mounting. Outline and panel cutout dimensions are depicted in Figure 2-1. Installation of panel mount adapters is shown in Figure 2-2.

2.2.2 OPTIONAL NEMA 414X ENCLOSURES

NEMA 4 and 4X enclosures are equipped with four pre-punched holes for mounting to a wall or bracket. A U-bolt can be used for mounting to a pipe support. The enclosure should be installed in a vibration free environment. If conduit is used to shield interconnecting cables, drains should be provided to reduce the possibility of condensate entering the enclosure. Outline dimensions for NEMA 4/4X enclosures are presented in Figure 2-3.

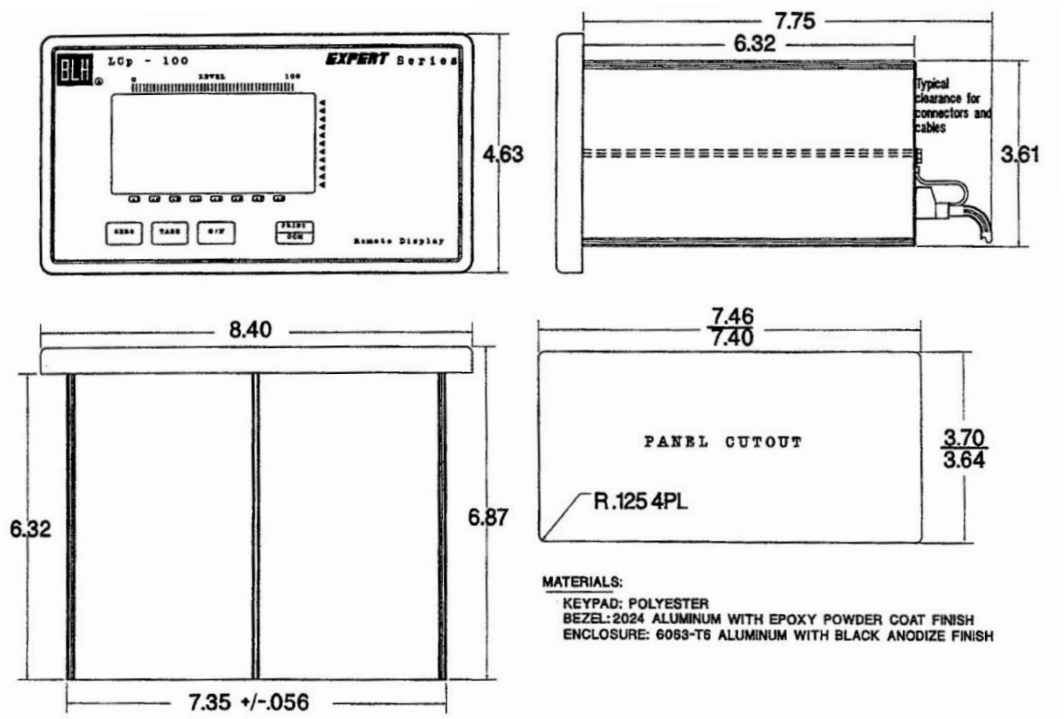

Figure 2-1. Panel Mount Outline Dimensions

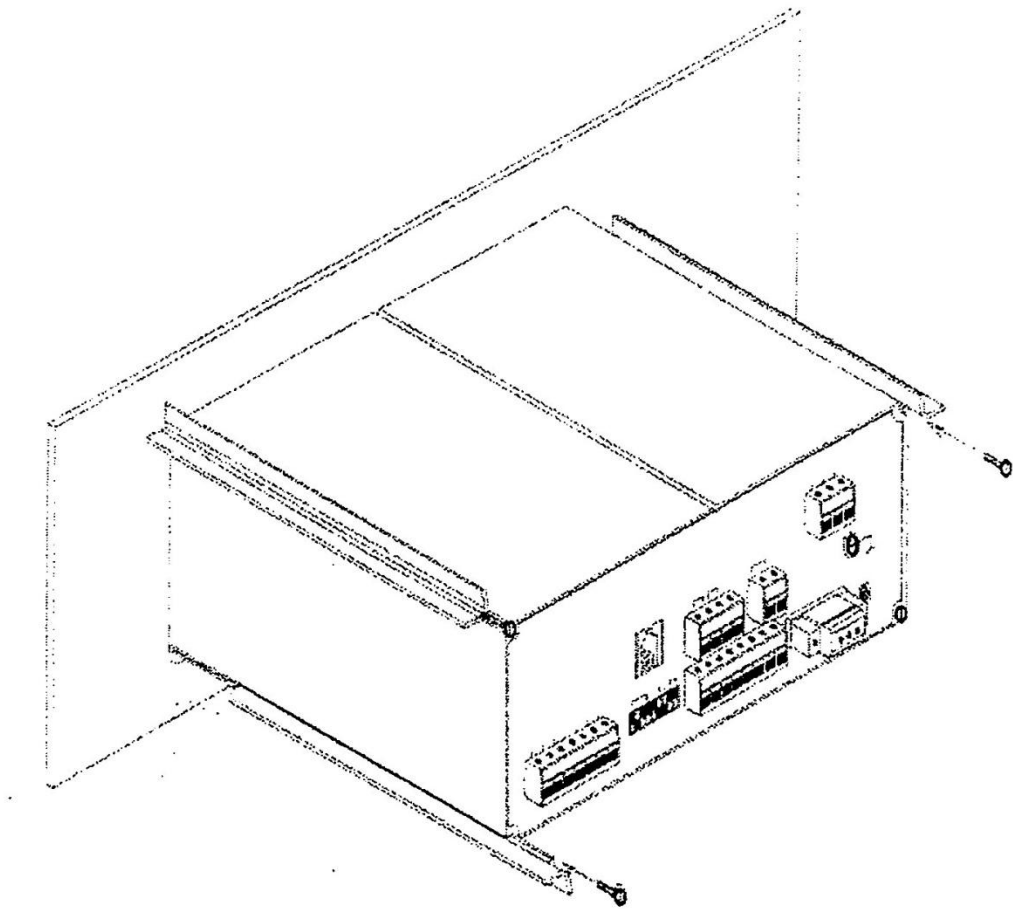

Figure 2-2. Panel Mounting Configuration

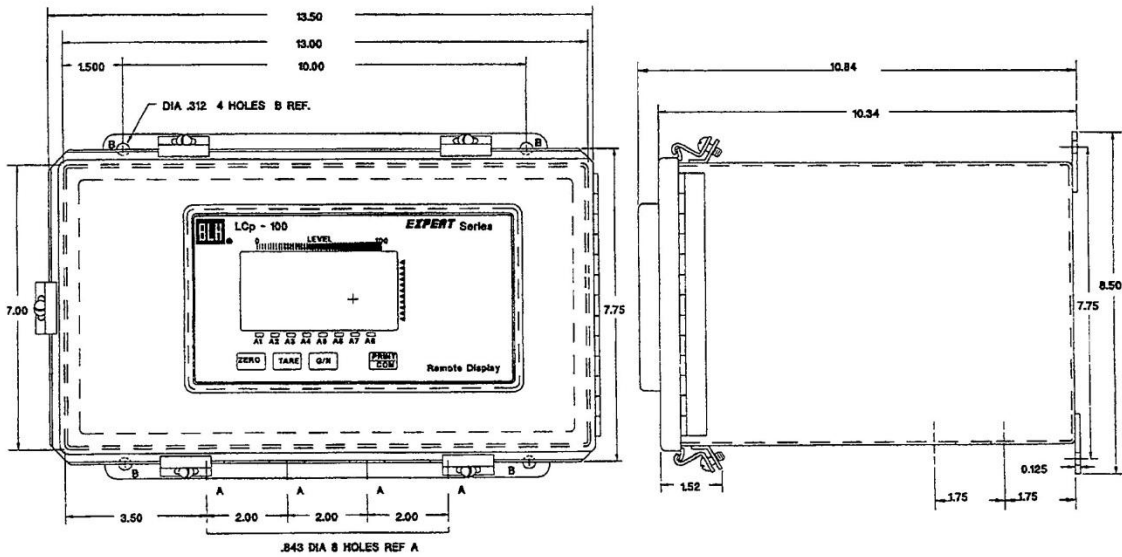

Figure 2-3. NEMA 4/4X Outline Dimensions

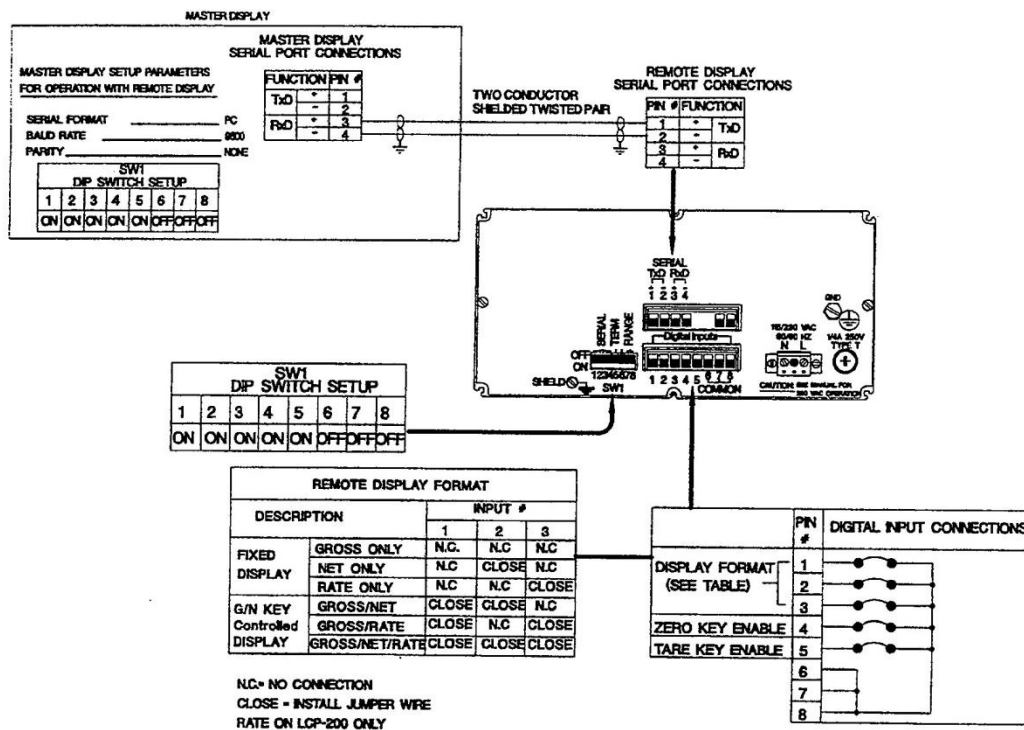

Figure 2-4. Interface Overview

2.3 ELECTRICAL CONNECTIONS

Figure 2-4 presents an overview of all wiring connections. Use this interface diagram for interface connections between the Remote Display and host instrument. Individual connections are discussed in the following paragraphs.

2.3.1 THE REMOTE DISPLAY REAR PANEL

Figure 2-5 shows the Remote Display rear panel. Call outs depict wiring locations for all electrical connections.

2.3.2 MAINS (AC) POWER

Remote Display instruments are shipped ready to operate at 115 Vac (50 or 60 Hz). For 220 Vac operation, remove the rear panel and change the internal voltage selection switch by performing the following:

- 1) Remove the mother board screws.
- 2) Slide the mother board out about 3 inches
- 3) Change the AC switch on the right-hand side of the board

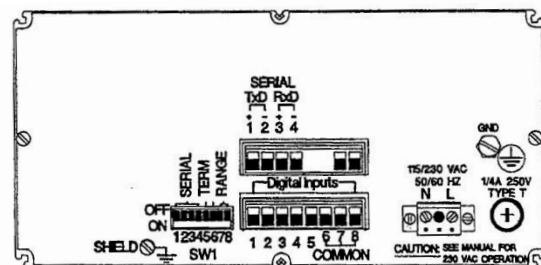

Figure 2-5. Rear Panel Connection Locations

Each instrument is protected with a 1/4 amp, 250 volt T type fuse located adjacent to the ac power socket. If the fuse opens, replace it with the same type, current, and voltage rating.

2.3.3 SERIAL COMMUNICATION

A 4-socket mating half connector is provided for serial communication wiring. Connect wires for both units as shown in Figure 2-6. Total cable length should not exceed 200 feet.

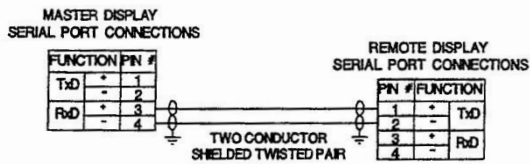

Figure 2-6. Serial Communication Wiring Configuration

2.4 INTRODUCTION

Remote Digital Display is accomplished using jumpers and DIP switch selections. Jumpers determine the front panel display status and DIP switch selection establish the communication interface. Jumpers are added to the rear panel Digital Input connector.

2.5 FRONT PANEL DISPLAY STATUS

Figure 3-1 gives a complete overview of jumper status designations and locations. Designated functions are discussed in the following paragraphs.

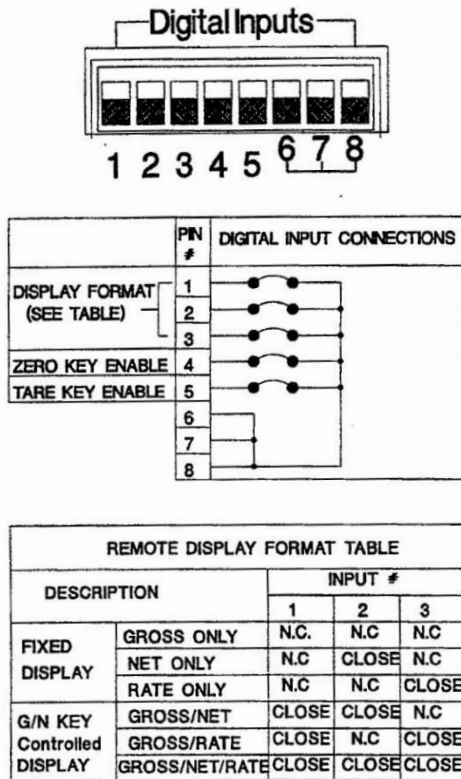

N.C. = NO CONNECTION
CLOSE = INSTALL JUMPER WIRE

Figure 3-1. Jumper Designations

2.5.1 DISPLAY MODE

The front panel display can be configured to track the front panel of the host LCp/2020 instrument or fixed to display only one mode of host operation. In tracking mode, any host mode change (i.e. Net/Gross/ Rate) is immediately transmitted and displayed upon the remote display front panel. If a fixed display mode is selected, the remote unit displays only the selected mode of operation regardless of changes made to the host device. For example, a remote LCp-200R can be fixed to display rate data only while the host LCp-200 freely changes from Gross to Net or Rate.

2.5.2 DISPLAY CONTROL

When any tracking display is selected, pressing the front panel GIN key changes not only the remote but also the host mode of operation. The remote display selection is transmitted back to the host and the host mode of operation changes accordingly. If the zero and tare keys are activated (next paragraph), all net, gross, rate, zero, and tare functions can be controlled from the remote display keypad.

2.5.3 ZERO AND TARE FUNCTIONS

For remote control of system zero and tare functions, add jumpers 4 and 5 as shown in Figure 3-1. Jumpers may be added independently as desired, i.e., zero only (4) or tare only (5).

2.6 COMMUNICATION CONFIGURATION

To ensure proper bi-directional communication between the remote display and the host, set DIP Switch SW1 on both units as shown in Figure 3-2.

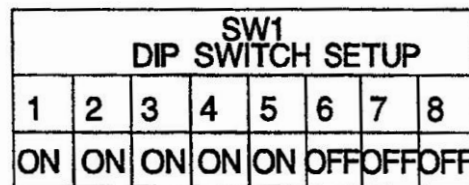

Figure 3-2. DIP Switch Designations

*Rate not available with LCp-100 based systems

SECTION 3. Operation

3.1 DISPLAY OPERATION

Upon power up of both units, remote digital displays provide digit-for-digit display duplication of the host device display readout. Display updates, occurring approximately ten times a second, include weight, rate*, level, and alarm status data. If a fixed display format is selected, the remote unit can display one mode such as net or rate* while the host device displays a different mode such as gross.

*Rate not available with LCp-100 based systems

3.2 REMOTE CONTROL FUNCTIONS

When enabled, tare, zero, and gross-net-rate* selection functions can be performed using the remote display front panel keys (Figure 4-1). Pressing a key causes the host to respond as if its own key had been pressed. The only exception is the PRINT/COM key, which has no function at this time.



Figure 4-1. Front Panel Key Functions



BLH

3 Edgewater Drive,
Norwood, MA 02062 U.S.A

Phone (781)298-2200

Fax (781)762-3988

www.vishaypg.com