

Title	xDevs.com XA1 - Preamp for Keithley 1801	
Size	Document Number	Rev
A3	https://dev.xdevs.com/issues/1246	0
Date:	Monday, November 09, 2015	Sheet 1 of 5

ISOLATED DOMAIN

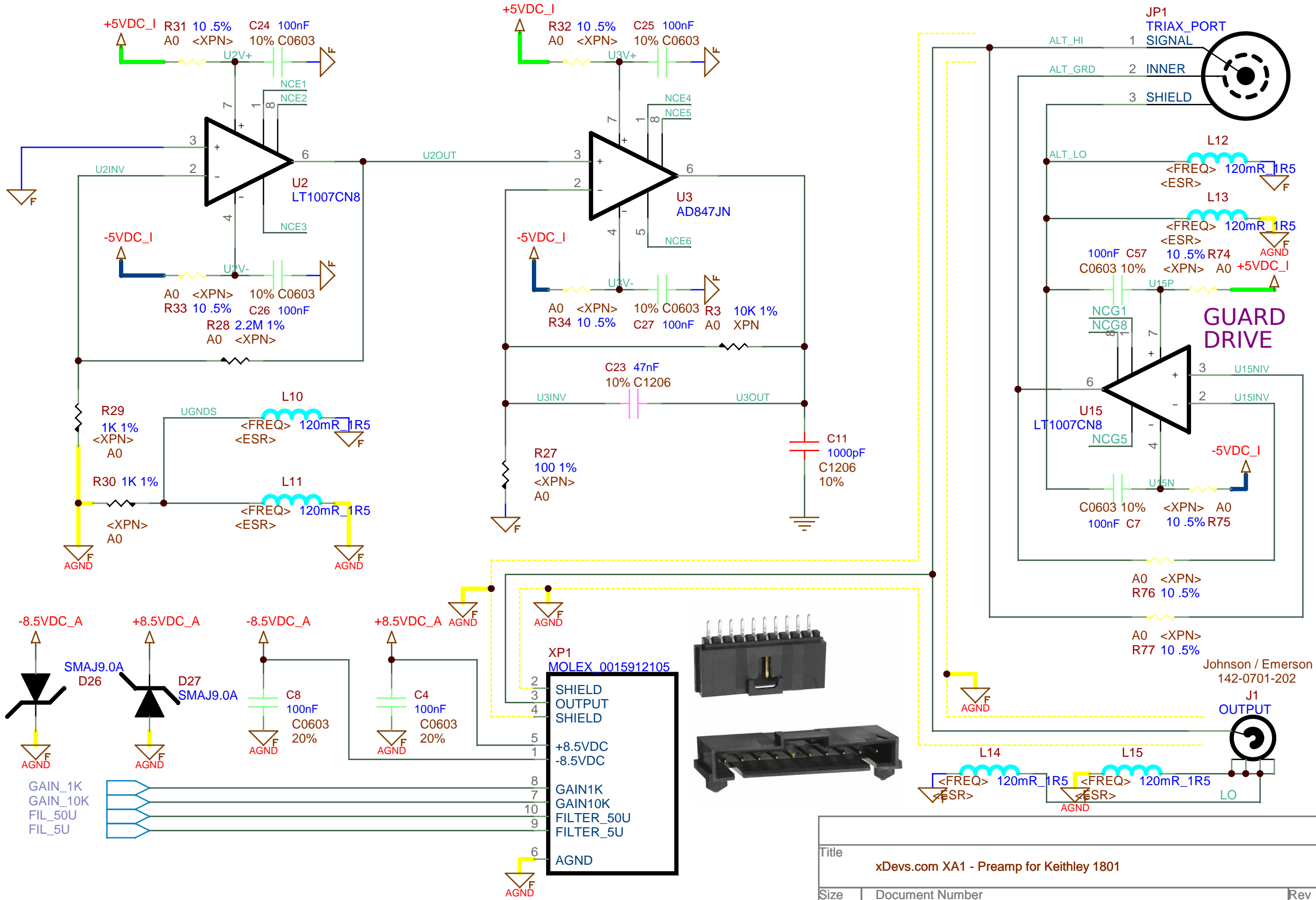

Title		
xDevs.com XA1 - Preamp for Keithley 1801		
Size	Document Number	Rev
A	https://dev.xdevs.com/issues/1246	0
Date:	Monday, November 09, 2015	Sheet 2 of 5

BATTERY OPTION

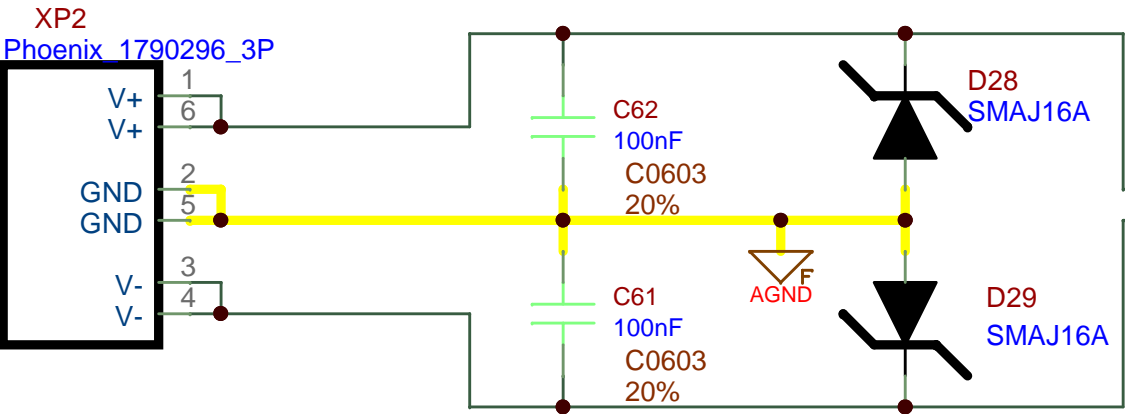

ISOLATED DOMAIN

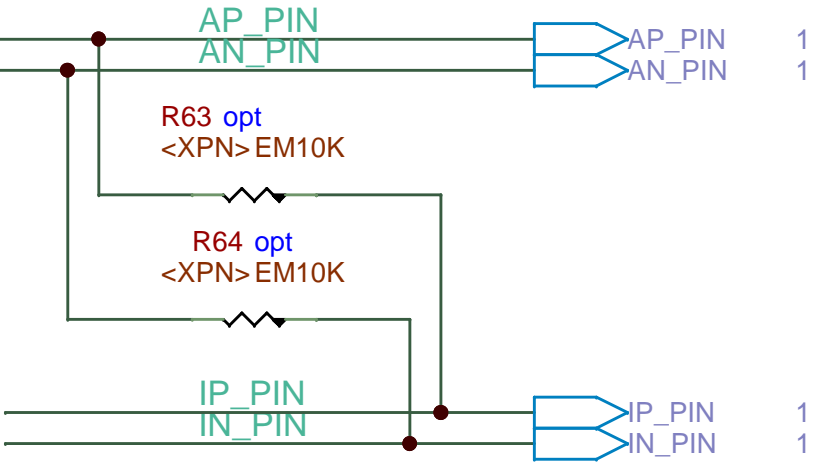

Option short to feed +/-5VDC power from +/-8.5VDC LD0s

Title		
xDevs.com XA1 - Preamp for Keithley 1801		
Size	Document Number	Rev
A	https://dev.xdevs.com/issues/1246	0
Date:	Monday, November 09, 2015	Sheet 3 of 5

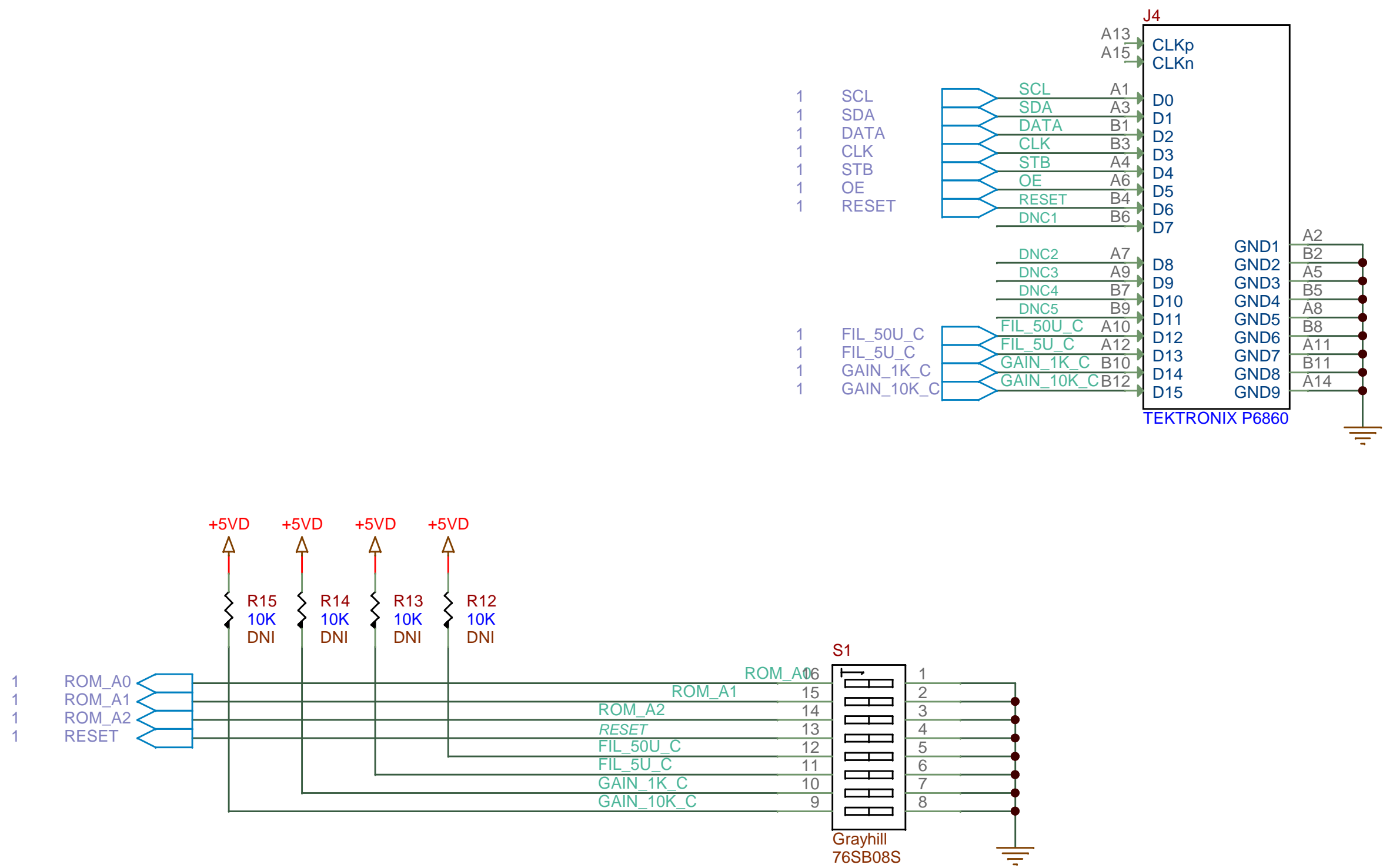

Title		
xDevs.com XA1 - Preamp for Keithley 1801		
Size	Document Number	Rev
A	https://dev.xdevs.com/issues/1246	0
Date:	Monday, November 09, 2015	Sheet 4 of 5

Revision changelist

A3 : Initial review

A4 : Second review

- * Change 0402 caps to 0603 for easier assembly
- * Move decoupling after 10R resistors at diode bridge
- * Update values and capacitor sizes
- * Reduced R65-68 3 times to fit higher Ciss of DN2510's FETs
- * Update sizes of some capacitors

A5 : Final review

- * Output Molex port redefined for better layout
- * Transformer drive from 74HC74 DFF

A6 : LTC option

- * Pushpull using stock parts

Title		
xDevs.com XA1 - Preamp for Keithley 1801		
Size	Document Number	Rev
A	https://dev.xdevs.com/issues/1246	0
Date:	Monday, November 09, 2015	Sheet 5 of 5